

# Dometic SERVICE

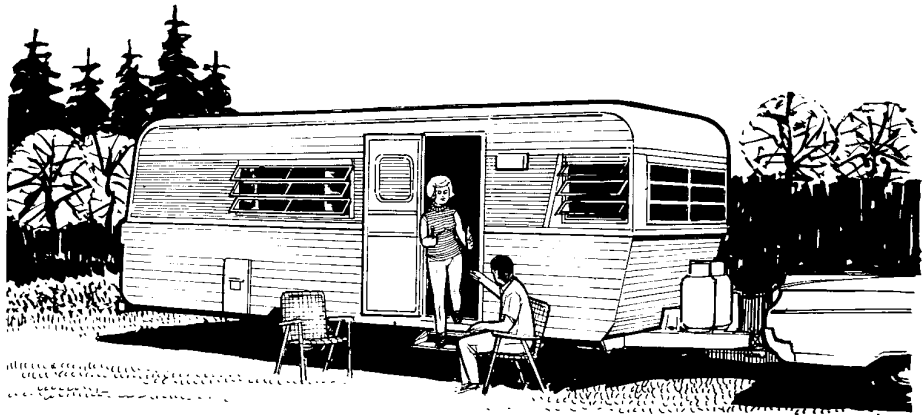

REFRIGERATORS  
for trailer installation

## SERVICE MANUAL

MC16  
M27, M28  
MA35, MA40  
M50, M52, MA52, MB52  
M70

Edition **1**  
Publication No.  
3472/Service  
February 1969

### EAST OF ROCKY MOUNTAINS

DOMETIC SALES CORPORATION  
2320 Industrial Parkway  
P.O. Box 450  
Elkhart, Indiana 45514

### WEST

DOMETIC SALES CORPORATION  
1441 Bonelli Street  
City of Industry, Calif. 91744

### CANADA

DOMETIC SALES of CANADA LTD.  
2270, Speers Road  
P.O. Box 212  
Oakville, Ontario L6J 5A2

SERVICE MANUAL FOR ABSORPTION REFRIGERATORS

The purpose of this manual is to assist the servicemen with the handling, installing and servicing of continuous absorption motorless refrigerators. It includes technical details relating to electric operation and bottled gas (liquified LP gas, petroleum gas) operation. This manual covers all models dating back to 1958 when DOMETIC was first introduced.

List of contents

Paragraph		Page
	Absorption cooling unit diagram .....	2
1	The domestic refrigerator .....	4
2	The absorption type cooling unit .....	5 - 6
3	The automatic defrosting device .....	6
4 - 8	Installation instructions for LP gas refrigerators .....	7 - 10
9	Cooling unit types .....	11 - 13
10	The gas thermostat type GDB .....	14
11	The gas thermostat type GR .....	15
12	The gas thermostat V-35 .....	16
13	The gas thermostat KCC .....	16
14	Cleaning valve or valve seat in the V-35 and KCC thermostat .....	16
15	Cleaning valve or valve seat in the GDB and the GR thermostat .....	17
16 - 17	The Bunsen type gas burner "B" .....	17 - 18
19 - 23	Service hints for burner "B" .....	18 - 19
24 - 25	The cylindrical burner "H" .....	19
26	The burner type "H" - Maintenance .....	20
27	The burner type "E" .....	21
28 - 35	Automatic flame failure devices .....	21 - 25
36 - 37	The flue system .....	25 - 26
38	Lighting devices .....	27 - 30
39 - 42	Gas thermostats, jet and by-pass screw types in different refrigerator models .....	31 - 33
43 - 46	Pressure measuring devices .....	34 - 37
47 - 48	Electric operation .....	37 - 38
49	Replacement of heating element in gas/el refrigerators .....	39
50	Service hints for electric operated refrigerators .....	40
51	Electric equipment and heating elements for different refrigerators .....	41
52	Amperage figures on rating plates .....	41
53 - 67	Service maintenance .....	42 - 45
68	Changing the door panel .....	46
69	Changing door opening from left to right .....	46
70 - 72	Operation analysis for cooling unit .....	47 - 48
73	Packing of defective units .....	48
74	Operation analysis for refrigerators operating on electricity .....	49
75	Operation analysis for LP gas refrigerators with burner "B" .....	50
76	Operation analysis for LP gas refrigerators with burner "H" and "E" .....	51
77	Customers notes .....	52 - 54
78 - 80	The Dometic gas burners .....	55

## 1. THE DOMESTIC REFRIGERATOR

The domestic refrigerator is a cabinet designed to keep perishable foodstuffs in a wholesome condition for a sufficiently long period to meet household requirements. To do this, a temperature of between 35°F (2°C) and 50°F (10°C) has been found most suitable, and the refrigerator must be capable of maintaining this temperature under the most severe conditions likely to be met.

The cabinet is an insulated container, fitted with shelves, and provision made for the storage of frozen foods and the freezing of water into ice-cubes of convenient size for household use.

In order to maintain the cabinet at the relatively low temperatures necessary for the storage of food and the making of ice, heat has to be extracted from the foodstuffs, the air admitted to the cabinet every time the door of the refrigerator is opened, the small amount of heat that enters through the insulated walls of the cabinet and from the water in the ice trays. The sum of these items constitutes the load on the cooling unit.

The Frozen Storage Compartment is inside the cabinet and attached to the Evaporator (that portion of the unit where the cooling effect is produced), consequently it is maintained at a low temperature.

The evaporator temperature is normally some 25° to 30°F (11° to 14°C) below the average cabinet temperature when the refrigerator is working in room temperatures of approximately 77°F (25°C), and this temperature difference will be increased or decreased by a rise or fall in the room temperature.

Inside the cabinet the air around the evaporator is cooled, becomes heavier and moves downwards. As it passes over the foodstuffs it extracts heat, becomes lighter and rises, thus creating an air circulation within the cabinet. (See fig. 2) The coldest position in the cabinet is immediately below the evaporator.

A thermostat or temperature regulator, which automatically controls the cabinet temperatures, is fitted to all except kerosene operated models.

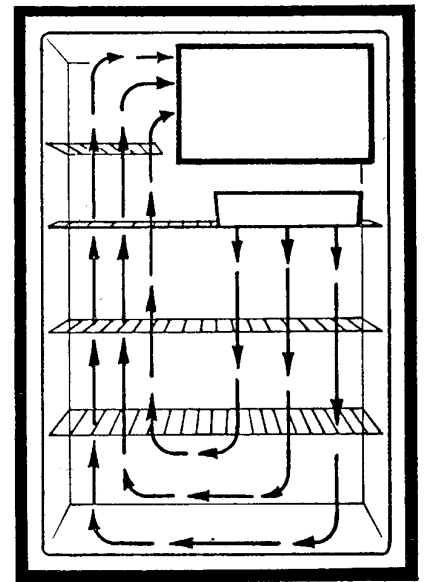

Fig. 2

## 2. THE ABSORPTION TYPE COOLING UNIT

The continuous absorption type of cooling unit is operated by the application of a limited amount of heat, gas, electricity or kerosene. No moving parts are employed.

The unit, (see fig. 1), consists of four main parts - the boiler system, condenser, evaporator and absorber. Further, this unit is provided with an automatic defrosting device (1) in fig. 1. All the parts are connected by tubes, the whole construction being of steel welded together.

The unit (in fig. 1) can either be run on electricity or gas. On the picture the unit operates on LP gas.

The unit charge consists of a quantity of ammonia, water and hydrogen at a sufficient pressure to condense ammonia at ordinary room temperature. The unit is then sealed off.

Some of the ammonia, in a relatively strong solution in water, is in the boiler system. When heat is supplied at point A on the picture (LP gas), bubbles of ammonia gas are produced which rise and carry with them quantities of weak ammonia solution. This weak solution passes into the tube (C), whilst the ammonia vapour passes into outer tube (D) and on to the point (E) where it is enriched by bubbling through the liquid before rising into the vapour pipe (F) and on to the water separator. Here any water vapour is condensed and runs back into the boiler system leaving the dry ammonia vapour to pass to the condenser.

Air circulating over the fins of the condenser takes up sufficient heat from the ammonia vapour to cause it to condense to liquid ammonia in which state it flows into the low temperature evaporator, situated at the base of the frozen storage compartment. The ammonia passes from the low temperature evaporator into the high temperature evaporator, situated at the rear inside the cabinet.

The low temperature evaporator and the high temperature evaporator are also supplied with hydrogen. The hydrogen passes across the surface of the ammonia and lowers the ammonia vapour pressure sufficiently to allow the liquid ammonia to evaporate. The evaporation of the ammonia extracts heat from the evaporator and from the food storage space, thereby lowering the temperature inside the refrigerator.

The mixture of ammonia and hydrogen vapour passes from the evaporator to the absorber vessel.

Entering the upper portion of the absorber is a continuous trickle of weak ammonia solution fed by gravity from the tube (C). This weak solution, flowing down through the absorber, comes into contact with the mixed ammonia and hydrogen gases and readily absorbs the ammonia from the mixture, leaving the hydrogen free to rise through the absorber coil and to return to the evaporator. The hydrogen thus circulates continuously between the absorber and the evaporator.

The strong ammonia solution produced in the absorber flows down to the absorber vessel and thence to the boiler system, thus completing the full cycle of operation.

The liquid circulation of the unit is purely gravitational. It is therefore essential that the unit stands upright.

Heat is generated in the absorber by the process of absorption. This heat must be dissipated into the surrounding air. Heat must also be dissipated from the condenser in order to cool the ammonia vapour sufficiently for it to liquefy. Free air circulation is therefore necessary over the absorber and condenser.

The whole unit operates by the heat applied to the boiler system and it is of paramount importance that this heat is kept within the necessary limits and is properly applied.

When the unit operates on electricity a heating element is fitted in the pocket (G) and the pump tube H will start to operate.

### 3. THE AUTOMATIC DEFROSTING DEVICE

The absorption unit shown in fig. 1 incorporates a unique, fully automatic defrosting device for the general food storage compartment, which eliminates the necessity for manual defrosting at frequent intervals normally associated with most conventional refrigerators in the medium size range. Furthermore, the time interval of each defrosting cycle, and the frequency, have been so arranged that during defrosting there is no noticeable effect upon the temperature of the foods stored in the refrigerator, and frozen food storage conditions can be maintained at all times in the frozen storage compartment.

#### How the automatic defrosting works

The defrosting action is brought about by diverting hot gas from the boiler to the high temperature evaporator at periodic intervals, and this hot gas melts the ice on the fins of the cooling coil. The resulting defrost water runs off into the drip tray.

The operation of the defrost cycle is completely automatic and the frequency with which it takes place is determined by an automatic siphon arrangement (see 1 in fig.1) in the boiler system, which periodically empties an associated siphon chamber, allowing hot gas to pass through the chamber and thence along a by-pass pipe to that section of the evaporator which cools the general food storage compartment.

During the normal refrigeration process, see a in fig. 3, the by-pass pipe outlet from the siphon chamber is closed by condensed liquid, and over a period of 20-30 hours solution continues to condense in the chamber and the liquid level rises slowly until it reaches the siphoning height (see b).

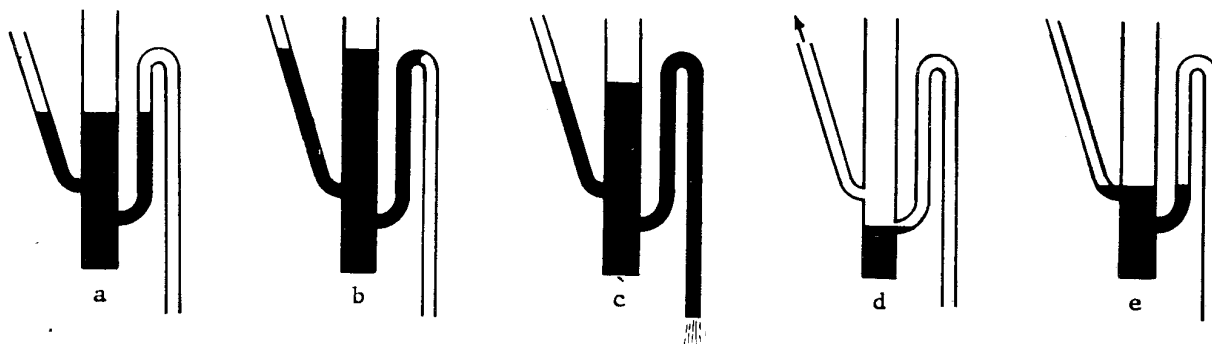

Fig. 3

The automatic siphon then empties the siphon chamber (see c) and thereby uncovers the outlet to the by-pass pipe. This allows the hot gas from the boiler to bypass the condenser, passing, instead, through the siphon chamber direct to the cabinet cooling coil of the evaporator (see d).

The defrost period lasts about half-an-hour, after which time solution condensing in the siphon tube once again covers the outlet to the by-pass pipe, and defrosting ceases (see e). The refrigerator unit then continues to operate normally for another 20-30 hours, until the liquid level in the siphon chamber again reaches the siphoning height, and the defrosting cycle is repeated.

#### 4. INSTALLATION INSTRUCTIONS FOR LP GAS REFRIGERATORS

##### General

Special care is necessary with the installation of LP gas refrigerators in trailers to ensure, firstly safety in operation, and secondly satisfactory operation under conditions that are usually much more difficult than is the case with the normal home installation.

The refrigerator must be installed on a firm floor and must be level. The latter point should be checked by using a spirit level and level both ways in the freezer compartment. A continuous movement, as in the trailers on tow, will not affect the operation if the rolling or pitching passes either side of level.

The operation will be least affected if the refrigerator is installed with the door parallel to the side wall of the trailer.

Whenever the trailer is parked, care should be taken that it is accurately leveled. When parking try to avoid having the wind blowing directly against the wall where the vent outlets are located.

It must be securely fixed so that it will not move when the trailer is in motion, but there should be means of releasing it easily for servicing.

Screw holes for securing the cabinet to the recess floor are provided in the cabinet support rails.

An access door on the outside wall in the back of the refrigerator must be installed for easy servicing.

The LP gas refrigerators are of the air-cooled type. Therefore it is of utmost importance that the air circulation round the unit parts behind the cabinet is unrestricted. Good refrigeration performance is dependant upon adequate ventilation of the refrigerator enclosure. This will be achieved by following the diagrams and instructions hereon.

It is important that the upper vent be installed as high as possible above the refrigerator.

Some methods of installation are shown in fig. 4 & 5. Each method has the inlet vent located on the side of the trailer or mobile home. Installation "A" in par. 5 is a typical undercounter installation for M28 or MA40 models and should only be used when "H" dimension for minimum clearances, as shown in par. 6 are maintained. Installation "B" is also recommended for the M28 or M40 models and may be used for MA52.

Installation "C" is recommended for MA52 and M70 models.

##### Important

The refrigerator must be completely enclosed at the top, bottom and sides. All joints in the enclosure must be tight to assure that no combustion products enter into the living area.

Clearances to combustible materials must be maintained as shown in par. 6.

Make sure that no part of the vent chimney walls cover the cooling unit when installation "B" or "C" is used or that the louvres in the sidewall vents are obstructed.

**5. Installation of Dometic refrigerators in trailers.**

The following figures show suggested ways of installations

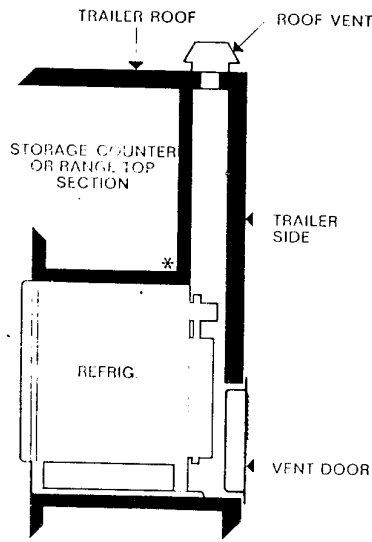

**FIGURE "A"**  
Most recommended method of  
Installing M 28, MA 40 & MA 52

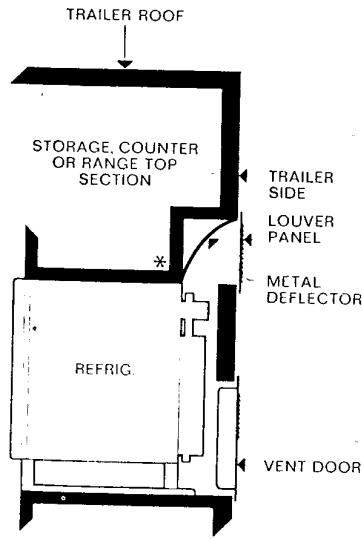

**FIGURE "B"**  
Alternate method of installing  
M 28 and MA 40 Dometic

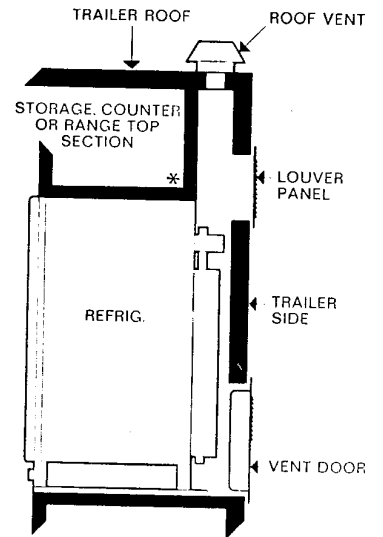

**FIGURE "C"**  
Most recommended method for  
M 70, also will increase  
efficiency for MA 52

\* Any dead space above the refrigerator should be sealed off at the rear top corner of the refrigerator cabinet.

All surfaces in the ventilation channel must be protected with a fire-proof material.

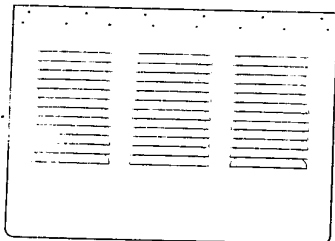

**Hinged Louvered Plate**  
Actual size 18" x 23"  
Cutout required 17 1/4" x 21 1/2"

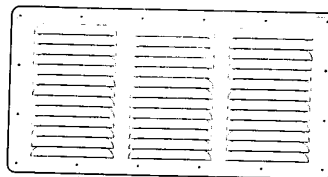

**Louvered Plate**  
Actual size 23" x 12 3/4"  
Cutout required 21" x 10 3/4"

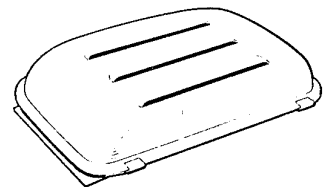

**Roof Vent**  
Actual size 4 1/2" high, 21" long,  
9 1/2" wide.  
Cutout required 4 1/2" x 17"

Roof venting method

Refrigerator roof vent with minimum opening area of 50 to 120 sq. inches. Recommended to use - special refrigerator roof vent specified or supplied by a Dometic distributor.

Service door with louvres

Recommended to use - special service door with louvres or hinged louvered plate specified or supplied by a Dometic distributor.

Side louvered plate - placed clearly above refrigerator with total opening area of minimum 50 to 120 sq. inches. Recommended to use - special side vent plate specified or supplied by a Dometic distributor.

**6. Cabinet and recess dimensions.**

REFRIGERATOR TYPE	OVER ALL DIMENSIONS			DOOR PROJECTION	BUILT-IN SPACE REQUIRED			MINIMUM INSTALLATION CLEARANCES		
	A	B	C		D	E	F	G	H	I
M28	21-1/8	20-1/4	29-1/4	1 3/4	21-7/8	20-1/2	29-1/2	6	6	1
MA40	22-3/4	21-3/8	32-1/8	1 1/2	23-1/2	21-5/8	32-3/8	6	7	1
MB52	23-3/8	21-3/8	40	1 3/4	24	21-5/8	40-1/4	7	7	2
M70	22-3/8	23-1/4	59-1/2	1 3/4	23	23-1/2	59-3/4	6	7	2

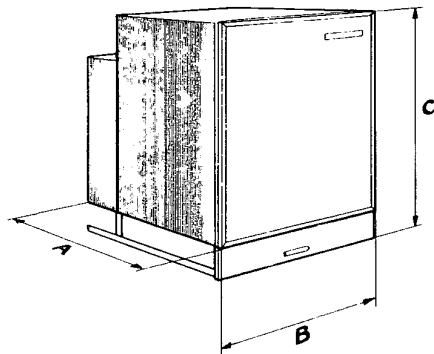

**EXTERIOR DIMENSIONS**

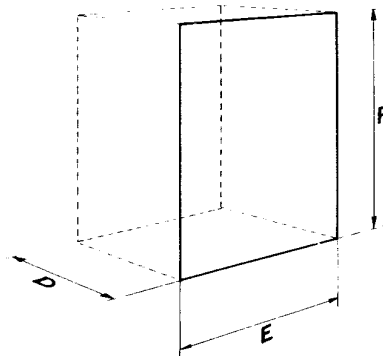

**BUILT-IN SPACE REQUIREMENTS**

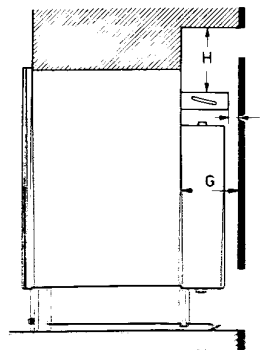

**MINIMUM CLEARANCES TO COMBUSTIBLE MATERIALS**

Fig. 5



### 7. Proper venting is required to ensure best performance.

Louvres in the trailer wall should have a free vent area according to the values given below.

Refr. Type	Vent areas required sq.in.	
	Inlet	Outlet
M28	50	50
MA35	50	50
MA40	50	50
M52, MA52, MB52	65	65
M70	120	120

Do not confuse the above required venting areas with the outside dimensions of the louvred doors or plates. Always measure actual louvred openings or roof vent openings. The more ventilation you provide, the better refrigeration performance you may expect.

It is most strongly recommended that advice be obtained from the distributor through whom the refrigerator is supplied before an installation of the refrigerator in a trailer is proceeded with.

### 8. Gas line

LP gas is highly inflammable and it is of extreme importance to ensure not only that all joints in piping carrying the gas from the storage bottle to the appliances burning are - and will remain - absolutely gas tight, but that any non-metallic packings used in such joints are made from materials that will not deteriorate from contact with LP gas.

The gas line should be free of kinks and sharp ends.

After installation, the gas should be turned on and all joints in the gas line checked for leaks up to the burner using soap and water solution. This check should be repeated periodically.

Do not fit any extension to the top of the flue. This is not only unnecessary, but can create draught conditions which can adversely affect correct combustion at the burner and consequently, the functioning of the cooling unit.

The refrigerator should be operated at an inlet gas pressure of 11" W.C.

Incoming gas pressure is controlled by the pressure regulator on the propane/butan bottle.

## 9. COOLING UNIT TYPES

Fig. 6

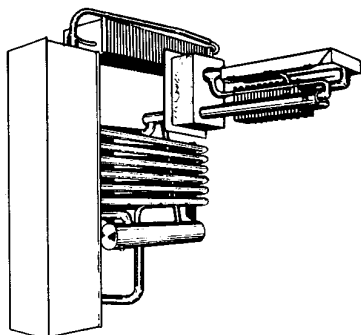

Cooling unit 27A (gas operation only)

for models M27a, b, c, d  
M1A35a, b, c, g

Fig. 7

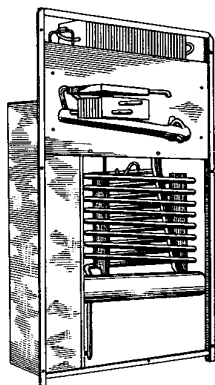

Cooling unit 53A (gas operation only)

for models M52a, b

Fig. 8

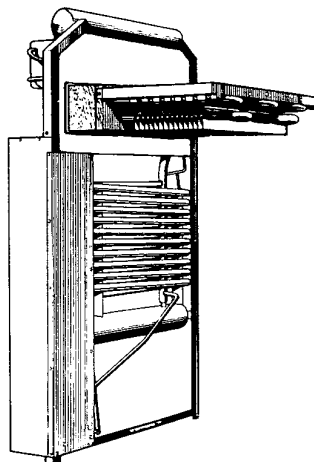

Cooling unit 75A (gas operation only)

for models M50a  
MKT500a, b

Fig. 9

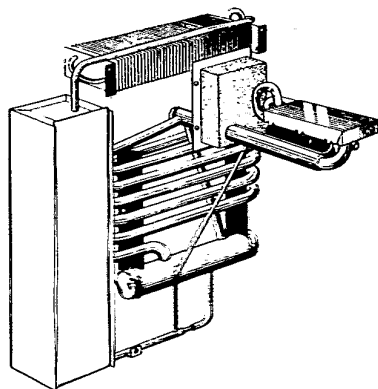

Cooling unit 210A (gas operation only)

for models M16a, b, c  
M16a, b, c

Fig. 10

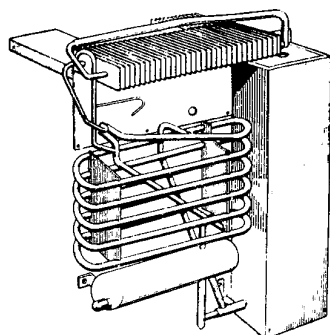

Cooling unit 236A (gas operation only)

for models M28a, c

Fig. 11

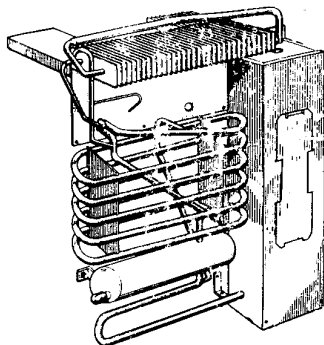

Cooling unit 239A (gas/electric operation)

for models M28b, d

Fig. 12

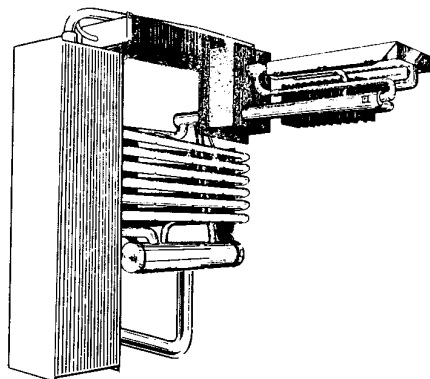

Cooling unit 310A (gas/electric operation)

for models MA35d, f

Fig. 13

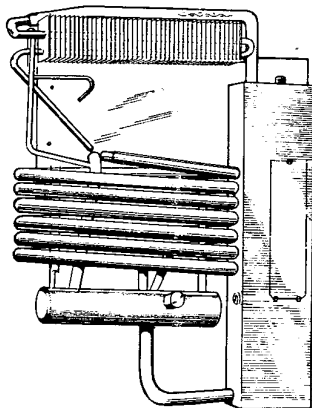

Cooling unit 313A (gas/electric operation)

for models MA40a, b, c

Fig. 14

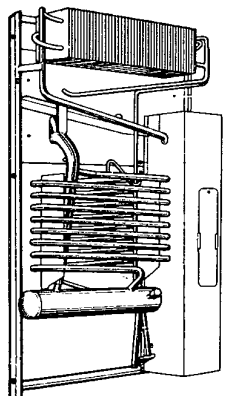

Cooling unit 510A (gas/electric operation)

for models M52c, d, e, f  
MA52a  
ME52a, b

Fig. 15

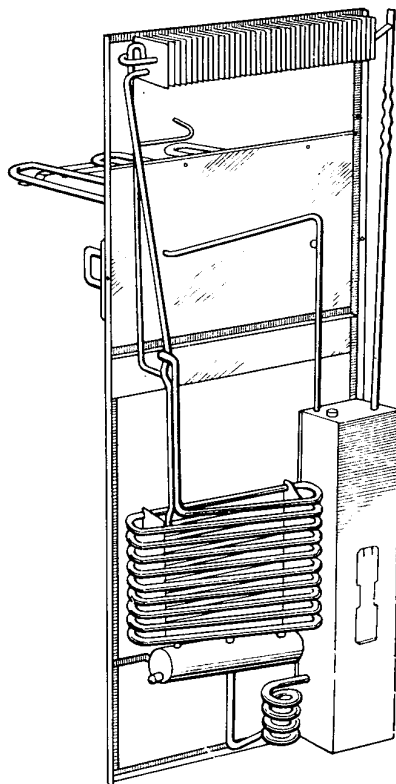

Cooling unit 512A (gas/electric operation)

for models M70a, b

## 10. THE GAS THERMOSTAT TYPE GDB

The construction is shown in fig. 16. The thermostat consists of three main parts:  
 Bellows system  
 Mechanism  
 Gas conducting member

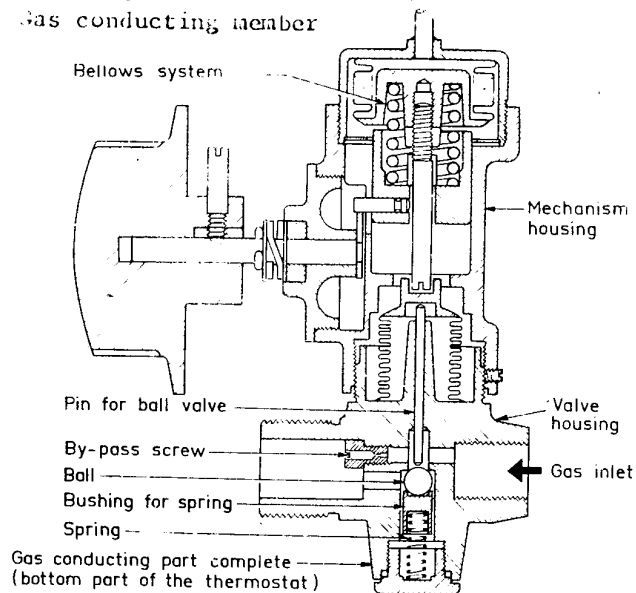

Fig. 16

### Bellows system

The system consists of a spring loaded bellows and a sensing tube. The tube is coiled at its free end.

### Mechanism

The spring load of the bellows can be regulated by means of a cam which is moved by turning the thermostat dial. The movement of the bellows caused by a change of the bulb temperature is transferred to the ball valve by a spindle and the valve pushing rod. Between the spindle and the rod there is a bellows separating the gas conducting member from the mechanism.

### Gas conducting member

The gas conducting member has an inlet fitted with an internal thread R 1/8". The outlet has an external thread R 3/8". In the outlet nipple there is a provision for fitting a by-pass screw. The valve is of the ball type and the ball is made of stainless steel.

The three main parts are screwed together and the joints are locked either by a stiffened sealing paste or by a lock screw. When the valve needs cleaning the bottom plug can be removed and the ball and the valve seat are accessible for cleaning.

The control dial of the thermostat (see fig. 17) provides for a wide range of cabinet temperature adjustments. Set on "0", the thermostat permits only a by-pass flow to the burner insufficient to operate the freezing unit. This is the defrost setting.

Set on "Max.", the burner will operate on full flame continuously and the maximum cooling effect of the unit will be obtained. Any of the numbered settings on the scale provides for cut-off of the main flame (allowing only by-pass flow to the burner) immediately the temperature of the evaporator - at the thermostat bulb - drops to the level provided by the thermostat dial's setting.

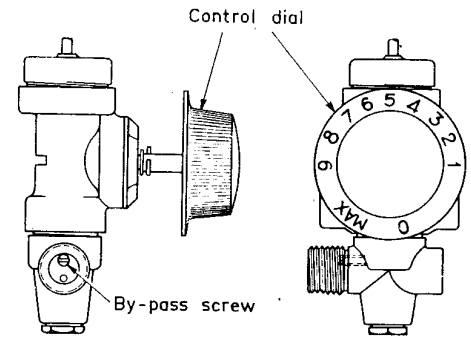

Fig. 17

## 11. THE GAS THERMOSTAT TYPE GR

The gas thermostat, type GR, consists of the following main parts. Compare fig. 18 and 19.

Bellows system

Mechanism with temperature regulator

Valve housing

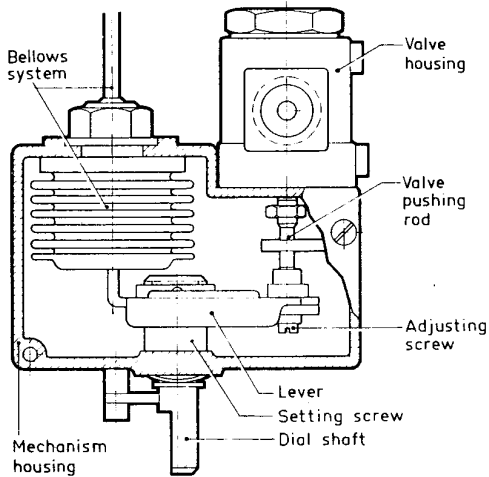

Fig. 18

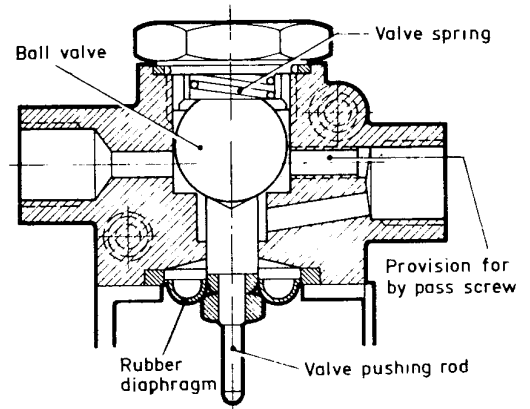

Fig. 19

### bellows system

consists of bulb, bulb tube and bellows. The bulb is inserted in a pocket on the evaporator of the cooling unit. The bellows system is filled with a gaseous medium which starts condensing when the bulb has been cooled down to about 32°F (0°C). The condensation causes a pressure decrease in the bellows system, whereby the bellows contracts. The movement of the bellows is transferred to the valve pushing rod via a lever.

Mechanism housing comprises bellows, lever, valve pushing rod and dial shaft with setting screw.

### Valve housing

is provided with inlet and outlet nipples and a gas valve consisting of a stainless steel ball, which is kept against the valve pushing rod by a spring. The valve pushing rod is fastened to a rubber diaphragm separating the valve housing from the thermostat housing. When the gas valve is shut a small amount of gas passes to the burner through the by-pass screw located in the valve housing.

The temperature setting is done by turning the dial shaft, the threaded part of which is left handed. By doing so the lever position is changed. The thermostat is provided with an adjusting screw to allow an accurate adjustment of the working range of the thermostat. This adjustment is made in factory and should never be readjusted in the field.

## 12. THE GAS THERMOSTAT V-35

The gas thermostat V-35 consists of three main parts:

Bellows system  
 Mechanism  
 Valve housing, see fig. 20

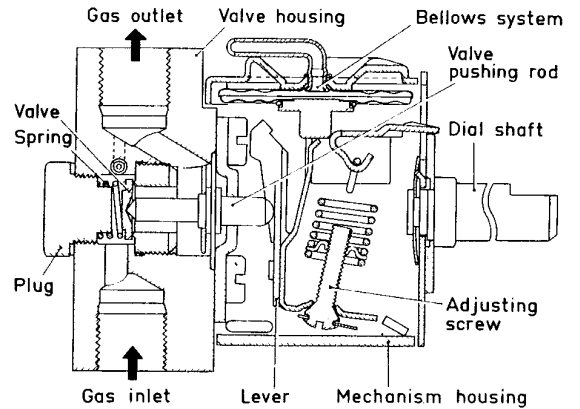
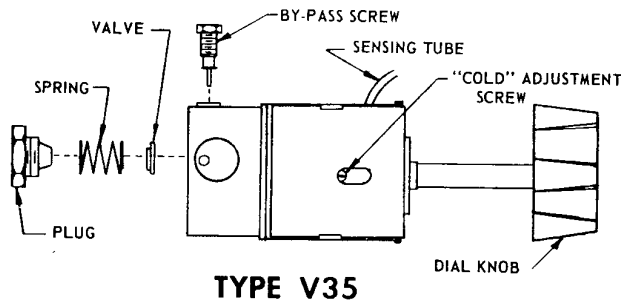

Fig. 20

## 13. THE GAS THERMOSTAT KCC

The gas thermostat KCC consists of three main parts:

Bellows system  
 Mechanism  
 Valve housing, see fig. 21

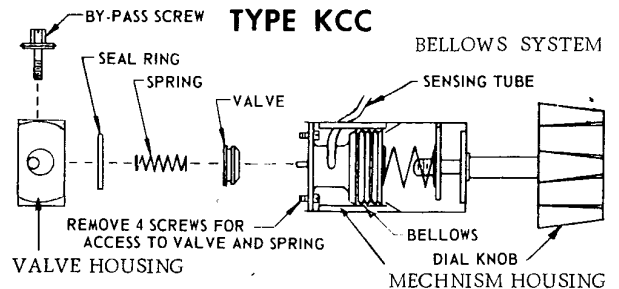

Fig. 21

## 14. CLEANING VALVE OR VALVE SEAT IN THE V-35 AND KCC THERMOSTATS

Dirt on the thermostat gas valve or seat prevents the thermostat valve from completely closing, consequently it lets through some gas when in closed position. This condition may prevent reducing the flame to the required minimum. It will cause too low cabinet temperature. This can be controlled by turning the thermostat dial to "0". If the flame does not go down to the low flame (by-pass flame) it will be necessary to clean the thermostat valve and valve seat. Note: The thermostat will not close to by-pass on setting "0", unless the thermostat bulb is cooled down to at least 5°C (40°F).

Proceed as follows:

V-35, see fig. 20

- a) Remove the plug, spring and valve and clean the valve and the valve seat.
- b) Also check that the size of by-pass screw is in accordance with tables (see pages 32-33).

KCC, cleaning valve and valve seat, see fig. 21

Note: The adjusting screw on all models of thermostats is preset at the factory and should never be readjusted.

## 15. CLEANING VALVE OR VALVE SEAT IN THE GDB AND THE GR THERMOSTAT

Dirt on the thermostat gas valve or valve seat prevents the thermostat valve from completely closing, consequently it lets through some gas when in the closed position.

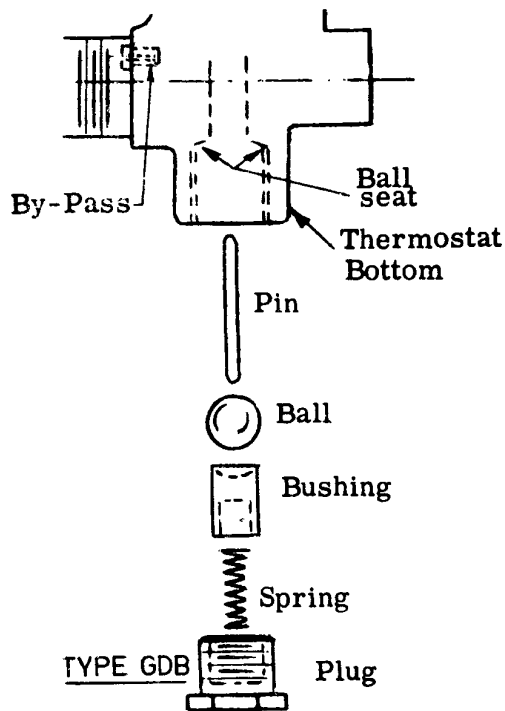

Fig. 22

This condition may prevent reducing the flame to the required minimum. It will cause too low cabinet temperatures.

This can be controlled by turning the thermostat dial to "0". If the flame does not go down to the low flame (by-pass flame) it will be necessary to clean the thermostat valve and valve seat.

Remove plug and clean the ball and valve seat (see fig. 22 and 23).

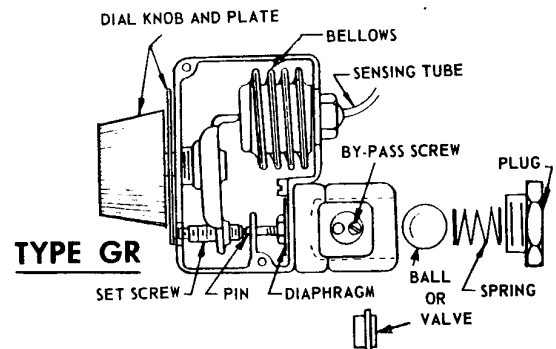
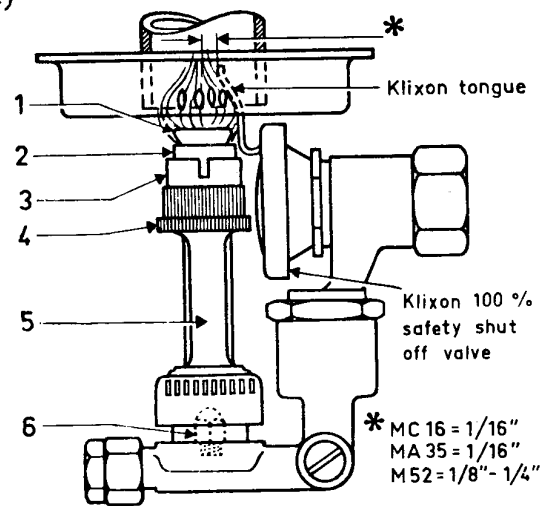

Fig. 23

## 16. THE BUNSEN TYPE GAS BURNER "B" (see fig. 24)

The Bunsen type gas burner consists of the following parts:

1. Burner inner stone (ceramic head)
2. Burner outer stone (ceramic ring)
3. Holder for outer stone
4. Lock nut
5. Burner barrel
6. Burner jet



Burner "B" Fig. 24

Aeration of the burner is varied by loosening the lock nut and screwing the outer burner stone holder upwards to decrease - downwards to increase - the amount of air to the flame. The lock nut should be tightened after aeration adjustment.

The inner and outer burner stones are ceramic and care should be used in handling them. It is important to ensure that they are properly seated in their holders.



## 17. The jet

The jet size is indicated by a number stamped on one flat of its hexagonal head. (see fig. 25).

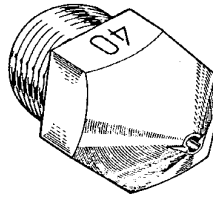

Fig. 25

The jet is drilled to precise limits and the indentations on either side of its outlet orifice are important in that they impart to the gas stream a turbulence which is necessary for satisfactory aeration of the flame.

It is most important that when cleaning of the jet is necessary, this is done by air blast and alcohol. It must never be cleaned by means of a pin or similar instrument, as this would enlarge or damage the orifice.

## 18. Burner Adjustment

The burner must be centrally located under the central tube and the burner head should be  $3/10$ " below the cupped part of the burner holder (see fig. 24).

In order to provide adjustment to the aeration of the flame, the holder carrying the outer stone can be screwed up or down on the burner barrel, thus varying the space between the tops of the outer and inner stones.

Screwing the holder up decreases the aeration of the flame and screwing it down increases the aeration. When correctly adjusted, the flame should be "soft" and have a slightly luminous tip (see fig. 52, page 55).

The tongue of the Klixon valve must also be adjusted correctly. It should be checked at the time of installation, that the factory adjustment has not been disturbed. The tongue must be positioned so that it receives sufficient heat from the burner. On the other hand, it should be checked that the tongue does not protrude so far that it IMPINGES on the main flame when alight. The figure 24 shows the approximate position of the Klixon tongue when correctly adjusted in relation to the burner head.

### SERVICE HINTS FOR BURNER "B"

## 19. Flame keeps going out when the thermostat cuts the flame to by-pass size

Klixon Safety Valve Tongue is too far away from the flame. Bend it towards the flame so that it can be heated sufficiently to keep the safety shut-off open.

In order to check if the tongue of the Klixon Safety Device is correctly positioned and properly heated, light the burner, turn the thermostat knob to setting "0" and leave it at this position for 5 to 10 minutes. If the flame goes out, bend the tongue slightly in the flame and repeat the test until a satisfactory position is found.

## 20. By-pass screw clogged

When the required cold temperature inside the cabinet is reached, the thermostat shuts off the main gas supply to the burner; however, a small amount of gas is still passing through the by-pass, enough to keep the tongue of the Klixon Safety Valve heated all the time, as already stated above. There is a very slight possibility that the by-pass screw hole is partially clogged. If this is the case, take out the by-pass screw and clean it. It is located on the left side of the gas thermostat (see fig. 16), inside the union nut, between the thermostat and outlet pipe.

## 21. Jet orifice clogged

When the jet orifice is clogged the flame will be too small on max setting which will cause the flame to be unstable and the colour of the flame will change from blue to yellow. If that is the case, remove burner barrel, unscrew jet and blow clear or wash in alcohol.

Do not use pin or wire to clean orifice.

## 22. Gauze in burner head clogged

If the gauze in burner head is clogged by fluff, flint or the like, the burner flame becomes yellow and unstable. Such a flame can cause carbon to accumulate in the central tube and obstruct the flue.

Remove the burner head and take out the gauze and clean it.

## 23. By-pass flame too large

By-pass flame is too large, causing the cooling unit to operate when the thermostat valve is closed. Exchange by-pass screw according to par. 40. On the GDB thermostat the by-pass screw is situated inside the inlet nipple of the thermostat and is accessible after unscrewing the union nut (see fig. 16).

## 24. THE CYLINDRICAL BURNER "H" (see fig. 26)

The cylindrical burner "H" consists of the following parts:

1. Burner barrel
2. Lock ring
3. Air adj. ring
4. Burner jet

The jet is located directly underneath the burner barrel. The size of the jet is indicated by a number stamped on one flat of its hexagonal head.

The jet is drilled to precise limits and without indentations at the outlet orifice (see fig. 27).

## 25. Burner adjustment

Aeration of the burner is varied by loosening the lock nut and screwing the air adjusting ring upwards to increase, downwards to decrease the amount of air to the flame. The lock nut should be tightened after adjustment.

When correctly adjusted, the flame should have a bright blue crown at the base of the flame and a slight buzzing noise (see fig. 53, page 55).

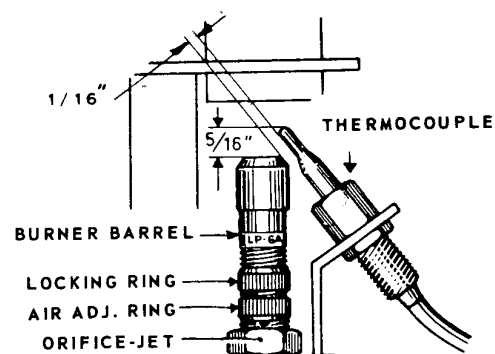

Fig. 26

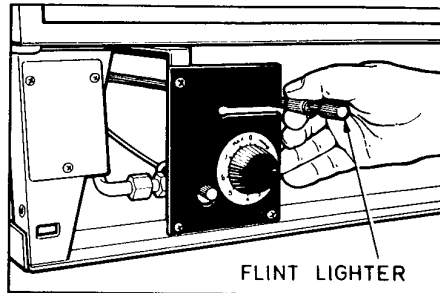

Fig. 27

## 26. BURNER TYPE "H" MAINTENANCE

(Important for proper performance)

After continued use of the flint lighter flint dust may accumulate along with fine rust (caused by condensation in the combustion tube entering the burner top) which may settle on the orifice opening and may affect the burner heat out-put and thus cut down on the cooling unit efficiency. The burner area and orifice should be cleaned and blown out once or twice a season, depending upon the use of the refrigerator.



(1) Remove flint lighter assembly from the refrigerator by unscrewing the knurled nut, behind the black thermostat bracket.

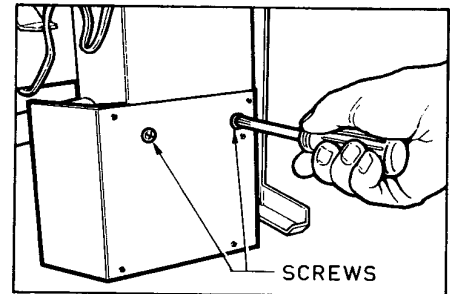

(2) From the rear of the refrigerator, through the access door of trailer, remove the two screws holding the flame guard.

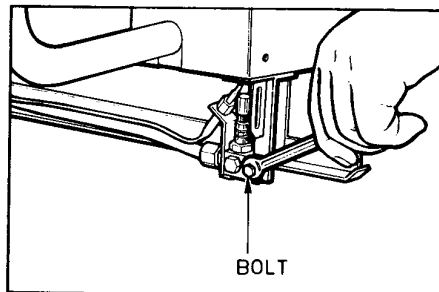

(3) Remove the chrome-plated bolt from the left side of the burner base and let the base drop down from the holder.

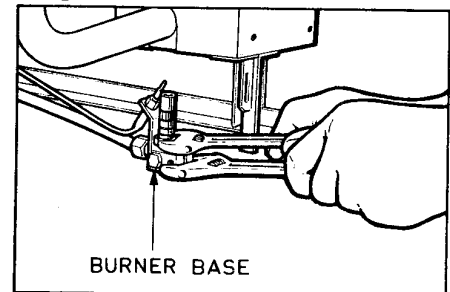

(4) Pull the base assembly to the left and with two crescent wrenches remove the jet and burner barrel from the burner base.

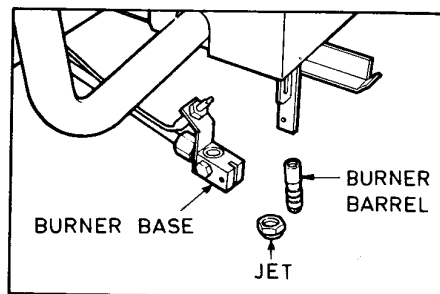

(5) Separate the jet and burner barrel and clean both with alcohol and air pressure **ONLY**. Do not use wires or other objects to clean the jet. If the jet is obstructed, replace it.

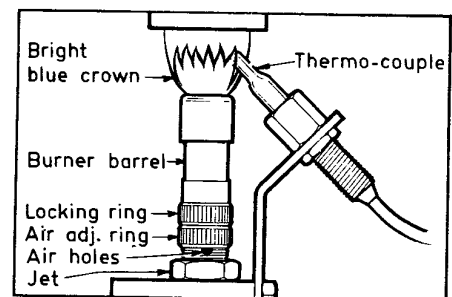

(6) The air-intake of the burner should be adjusted by means of the air adjustment rings so that a slight roaring sound is heard and so that the flame has a bright blue crown at it's base. (See above and fig. 53, page 52.)

The cylindrical burner "H" is provided with the Junker thermoelectric safety device designated STG 1.

When the thermocouple is in correct position it is in an approximate 45° angle to the burner. The adjustment should be made by bending the thermocouple holder. The nut which holds the thermocouple to the bracket should be tight at all times. Make sure that the thermocouple tip is in the flame.

## 27. THE BURNER TYPE "E" (see fig. 29)

This burner has the jet and jet adapter horizontally located and the burner mixing tube is formed as a bend with vertical outlet.

The primary air inlets are pre-set and therefore not adjustable. The burner and the burner holder are made in one piece.

The shape of the jet is the same as for the burner type "B", but without indentations at the outlet orifice. See fig. 30.

The jet is drilled to precise limits.

The size of the jet is indicated by a number stamped on one flat of its hexagonal head.

The burner type "E" is provided with the Junker thermoelectric safety device designated STG 1 and the thermocouple tip is pre-set.

The correct flame should have a bright blue crown at the base of the flame and a slight buzzing noise (see fig. 54, page 55).

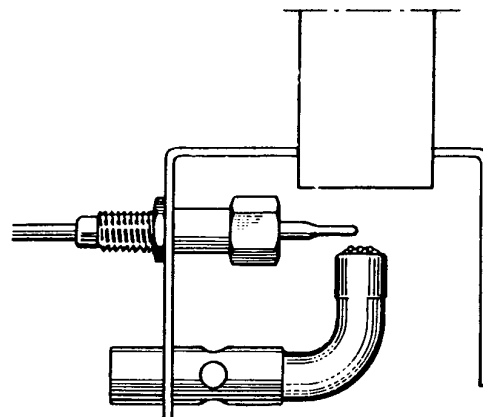

Fig. 29

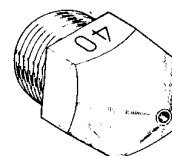

Fig. 30

## 28. AUTOMATIC FLAME FAILURE SAFETY DEVICES

All gas operated or combined gas/electric refrigerator models dealt with in this service manual are equipped with an automatic failure device.

The purpose of incorporating an automatic flame failure device in the burner assembly is to prevent unburned gas to escape from the burner and to avoid a fire hazard, if, for some reason or other, the flame has been extinguished or blown out.

The automatic flame failure devices in use are either the Klixon Safety Valve or the Junker Thermoelectric Safety Device model STG 1.

## 29. The Klixon safety valve

This type of safety valve has been used on the gas refrigerator burners for many years.

The Klixon safety valve consists of a bi-metallic disc which is connected with a valve.

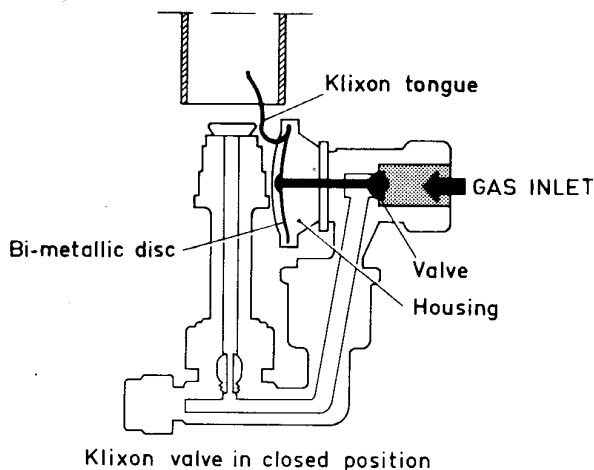

Fig. 31

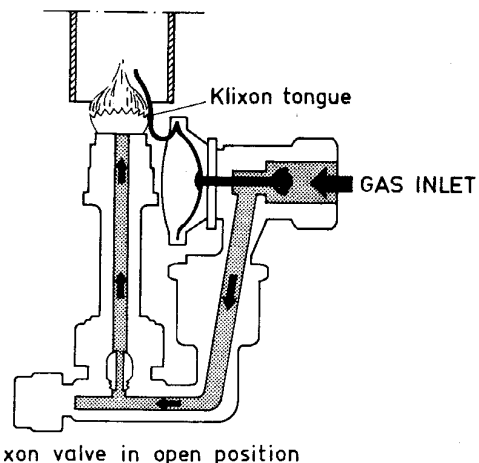

Fig. 32

At normal temperatures the disc is concave and the valve is closed. When heat from the lighting flame is applied to the housing, the temperature increases until the bi-metallic disc snaps into convex shape with an audible click, opening the valve and permitting gas to flow to the burner (see fig. 32). The bi-metallic disc temperature is controlled by means of an aluminium tongue which is rolled over the housing. This tongue is in contact with the flame and conducts sufficient heat back to the disc in the housing to keep the valve in open position. If the flame is extinguished the disc cools and snaps back to cold position as shown in fig. 31. This closes the valve and the gas supply is thus shut off whenever the flame goes out.

The Klixon valve opens at a temperature of approx.  $130^{\circ}\text{C} - 135^{\circ}\text{C}$  or  $266^{\circ}\text{F} - 274^{\circ}\text{F}$  and closes at a temperature of approx.  $74^{\circ}\text{C} - 80^{\circ}\text{C}$  or  $165^{\circ}\text{F} - 176^{\circ}\text{F}$ .

### 30. Testing the Klixon valve

- a) When heat is applied the valve should snap open, and after the flame is extinguished the valve should snap closed.
- b) If the valve fails to open and close with an audible snap, replace the Klixon valve.
- c) If the Klixon valve housing is leaking, replace the Klixon valve.
- d) The Klixon valve cannot be adjusted or repaired.

### 31. The Junker thermoelectric safety device model STG 1 (see fig. 33)

The Junker safety device consists of the following parts:

1. Spring loaded push button
2. Gas valve
3. Housing
4. Sensing element with the hot junction of the thermocouple (Feeler)
5. Enamel insulated copper thread
6. Electromagnet
7. Outer tube
8. Armature
9. Spring

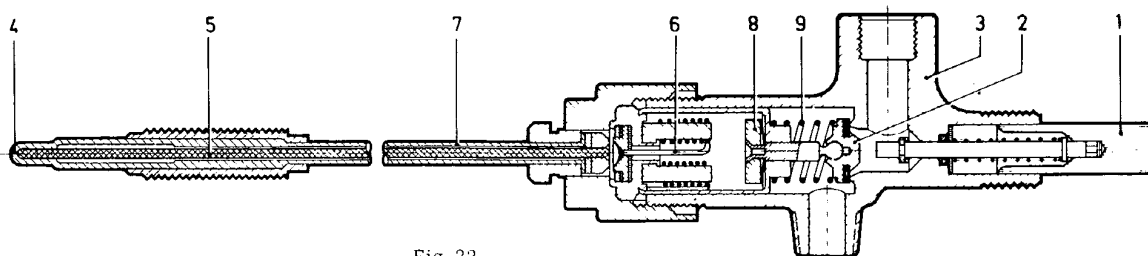

Fig. 33

The thermoelectric safety device functions as follows:

By pressing the push button (1) the gas valve (2) is opened and the gas can pass the housing (3) on to the burner. At the burner the feeler (4) is located. When the gas flame of the burner is lit, some heat is transferred to the feeler (4). The hot junction of the thermocouple is thus heated and an electric current is generated. This current passes through the copper wire (5) to the electromagnet (6) and back through the outer tube (7). As soon as the electric current is generated, the electromagnet attracts the armature (8) with the valve (2). The push button can then be released.

As long as current is flowing, the valve is kept open and allows gas to pass to the burner.

When the flame is extinguished, the heat transfer to the hot junction is interrupted and no electric current is generated. The armature (8) with the valve (2) is then forced back by the spring (9) and the gas flow through the valve (2) is closed.

**Important:** When lighting the burner the push button (1) should be pressed firmly, otherwise the gas may not get to the burner properly.

### **32. Junker safety valve adjustments (burner "H")**

When the thermocouple is in the correct position it is in an approximate  $45^{\circ}$  angle to the burner. The adjustment should be made by bending the thermocouple holder. The nut which holds the thermocouple to the bracket should be tight at all times. Make sure that the thermocouple tip is in the flame. Should the flame still go out as soon as the push button is released, check if the thermocouple connection at the safety valve is tight. If provisions for checking the safety valve and the thermocouple are not available, replace both. The flame blowouts can also be created by an excessive wind or passing truck (when the refrigerator is located on the left side of trailer). Check the installation.

### **33. How to replace the thermoelement of the Junker flame failure device (burner "H")**

1. Unscrew the plug A from the valve housing B see fig. 34.
2. Loosen the position nut C and the lock nut D.
3. Unscrew the nut C and release the thermoelement E from the holder F.  
Remove the nut D.
4. Bend the new thermoelement in the same shape as the old element.  
Screw the nut D onto the new element.
5. Put the feeler through the hole of the holder F and screw on the position nut C until it is tightened to the feeler. This nut must be tightened as far as it will go on the feeler in order to position the feeler in relation to the burner flame.

6. Tighten the lock nut D against the holder F and check the distances given in the figure.
7. Screw on the plug A to the valve housing B and be careful not to destroy the threads of the aluminium cap of the housing. The plug A must be properly tightened to the valve housing to ascertain a good contact between the thermoelement and the magnetic coil within the housing.

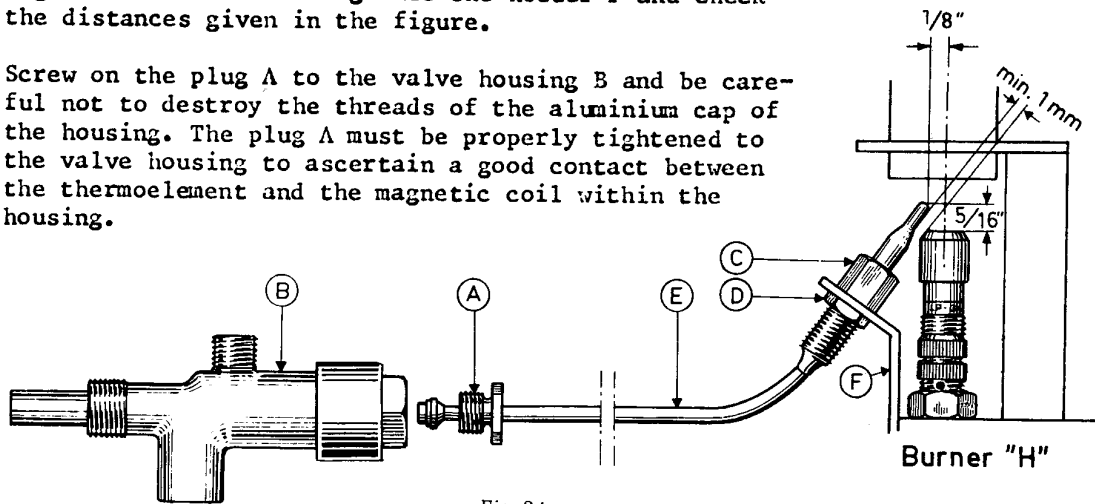

Fig. 34

### 34. How to replace the thermoelement of the Junker flame failure device (burner "E")

Back off nut A (see fig. 35) from valve housing B. Back off nut C and locknut D. Unscrew nut C and remove spacer G. Withdraw thermoelement E from holder F. Also remove nut D. Bend the new element to the same shape as the old one. Screw nut D in place on the new element. Insert the tip of the element in the hole in holder F and fit spacer G in place. Tighten nut C as far as it will go against the shoulder on the element tip, making sure that nut D is not tightened in the process. Tighten locknut D against the bracket, using a spanner, holding nut C with another spanner if necessary. Make sure the element tip assumes the position shown in fig. 35. Screw nut A into valve housing B, being careful not to damage the aluminium threads. Nut A must be tightened sufficiently to provide good contact between the thermoelement and the electromagnet coil in the valve housing. Note that the spacer G comes in two sizes: 12 mm long for model M28 and 10 mm for MA40, MB52 and M70.

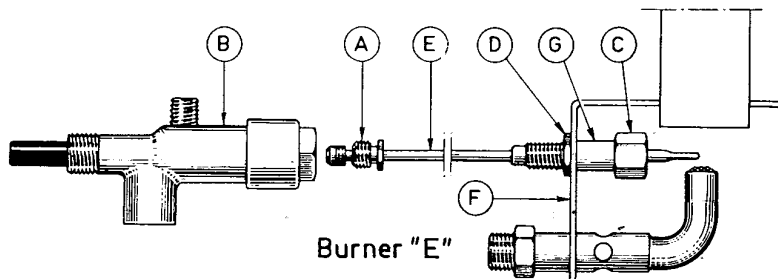

Fig. 35

### 35. Replacement of the safety valve magnet 200 09 99-00/9

If the safety valve magnet, fig. 36, is defective, it cannot be repaired but must be replaced.



Fig. 36

When the safety valve magnet needs replacement proceed as follows (see fig. 37):

1. Unscrew the connection plug (1) on the thermocouple from the housing nut (2).
2. Unscrew the housing nut (2) and remove the defective safety valve magnet (3) from the housing (4).

3. Fit a new magnet valve and ensure that it is properly inserted in the housing (4).
4. Fit the housing nut (2) and the connection plug (1) and check that a good contact between the contact plug (5) on the thermocouple and the contact (6) on the safety valve magnet is obtained.

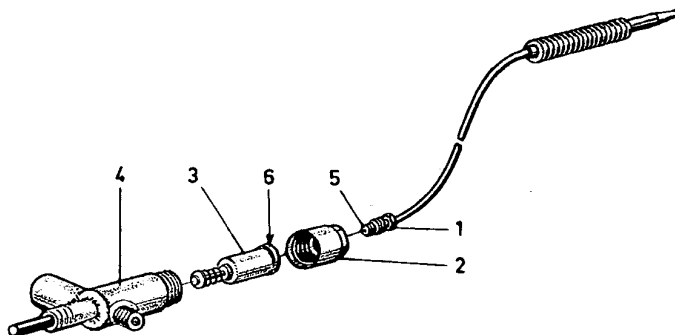

Fig. 37

### **36. THE FLUE SYSTEM**

The flue system consists of the following parts:

- 1) Central tube (built-in part of the boiler system and cannot be removed)
- 2) Flue
- 3) Flue baffle with support wire
- 4) Flue cap

The purpose of the flue system is to provide a draft which will pull the burner flame in to the central tube and supply sufficient primary and secondary air to the flame.

The right flue draft will not be obtained until after the burner has heated the flue system to the proper temperature.

The flue baffle which is inserted in the central tube distributes the heat produced by the burner to the boiler system.

It is important that the correct size of baffle is used and that it is correctly located in the central tube in order to obtain the best cooling performance. The size and the distance between the lower end of the baffle and the lower end of the central tube for different refrigerator models are shown in par. 37, page 26.

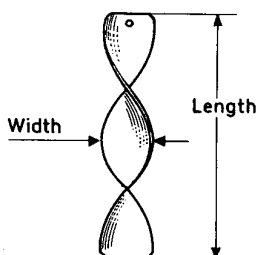

Fig. 38

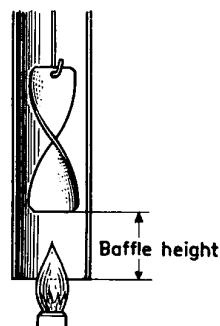

Fig. 39



**37. Baffle sizes and height in different refrigerator models**

Model	Equipment	Baffle Width x Length		Baffle Height	
		mm	inches	mm	inches
M16a,b,c	16B2	20x50	3/4x2	100	4
M16c	16B5	20x50	3/4x2	100	4
MC16	15B5	20x50	3/4x2	100	4
MC16b	16B12	20x50	3/4x2	100	4
MC16c	16B11	20x50	3/4x2	100	4
M27a,b,c	27B1	20x100	3/4x4	75	3
M27d	27B4	20x100	3/4x4	75	3
M28a	28B1	16,5x120	5/8x4 3/4	75	3
M28a	28B2	16,5x120	5/8x4 3/4	75	3
M28a	28B3	16,5x120	5/8x4 3/4	75	3
M28b	28EB1	16,5x120	5/8x4 3/4	75	3
M28b	28EB2	16,5x120	5/8x4 3/4	75	3
M28c	28B4	16,5x120	5/8x4 3/4	75	3
M28d	28EB3	16,5x120	5/8x4 3/4	75	3
MA35a	27B4	20x100	3/4x4	75	3
MA35b	35B2	20x100	3/4x4	75	3
MA35c	35B1	20x100	3/4x4	75	3
MA35d	35EB1	20x100	3/4x4	75	3
MA35f	35EB2	20x100	3/4x4	75	3
MA35g	35B3	20x100	3/4x4	75	3
MA40a	40EB1	20x100	3/4x4	75	3
MA40b	40B1	20x100	3/4x4	75	3
MA40c	40EB2	20x100	3/4x4	75	3
MKT500a,b	723GD	26x225	1x9	50	2
M50a	50B4	26x225	1x9	50	2
M52a	52B1	20x150	3/4x6	50	2
M52b	52B3	20x150	3/4x6	50	2
M52c,f	52B2	20x150	3/4x6	50	2
M52d,e	52EB1	20x150	3/4x6	50	2
MA52a	52EB2	20x150	3/4x6	50	2
MB52a	52EB3	20x150	3/4x6	50	2
MB52b	52EB4	20x150	3/4x6	75	3
MB52c	52EB4	20x150	3/4x6	75	3
M70a	70EB1	20x150	3/4x6	75	3
M70b	70EB2	20x150	3/4x6	75	3
M70b	70EB3	20x150	3/4x6	75	3

### 38. LIGHTING DEVICES

The lighting devices incorporated in different models of Dometic refrigerators are as follows:

- 1) The wick lighter (see fig. 40)
- 2) The zip tube lighter (see fig. 41)
- 3) The flint lighter (see fig. 42 and 43)

Lighting the burner is an operation that the user can perform by following the illustrated instructions which are printed in "Instructions for use" and also on a sticker attached to the inside of the control door of the refrigerator.

Gas equipment incorporating:

GDB thermostat with 8" W.C. pressure regulator  
Burner type "B"  
Wick lighter  
Klixon type safety valve  
Fig. 40

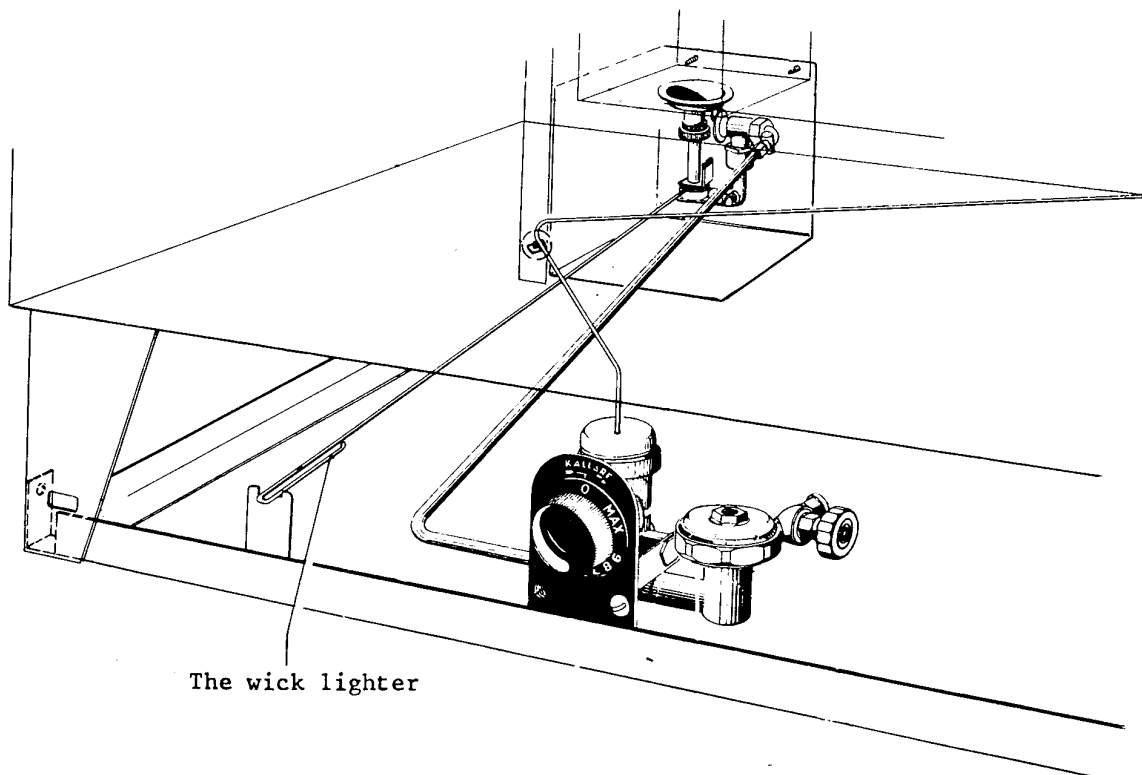
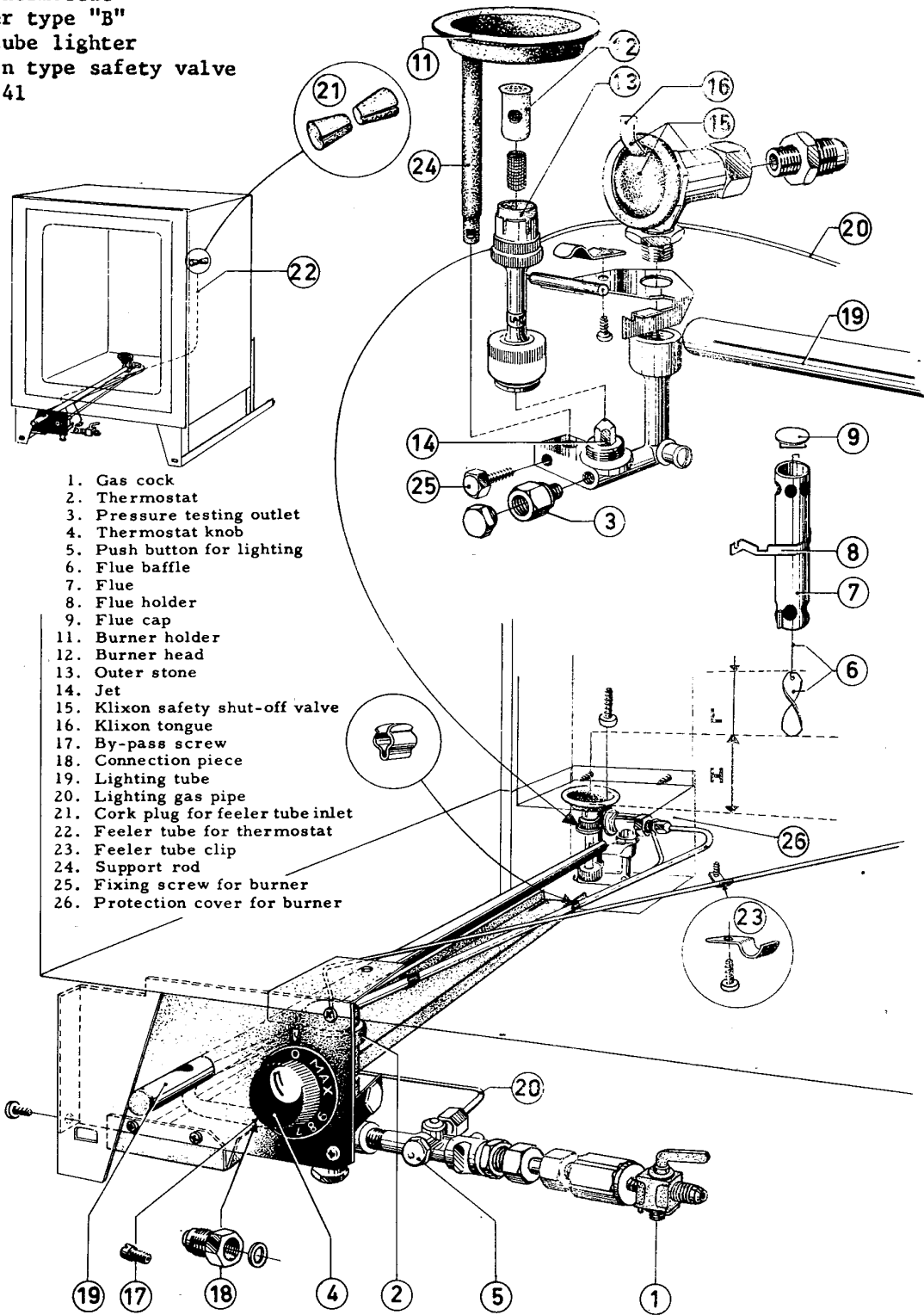

Fig. 40

Gas equipment incorporating  
 GDB thermostat  
 Burner type "B"  
 Zip-tube lighter  
 Klixon type safety valve  
 Fig. 41



1. Gas cock
2. Thermostat
3. Pressure testing outlet
4. Thermostat knob
5. Push button for lighting
6. Flue baffle
7. Flue
8. Flue holder
9. Flue cap
11. Burner holder
12. Burner head
13. Outer stone
14. Jet
15. Klixon safety shut-off valve
16. Klixon tongue
17. By-pass screw
18. Connection piece
19. Lighting tube
20. Lighting gas pipe
21. Cork plug for feeler tube inlet
22. Feeler tube for thermostat
23. Feeler tube clip
24. Support rod
25. Fixing screw for burner
26. Protection cover for burner

Fig. 41

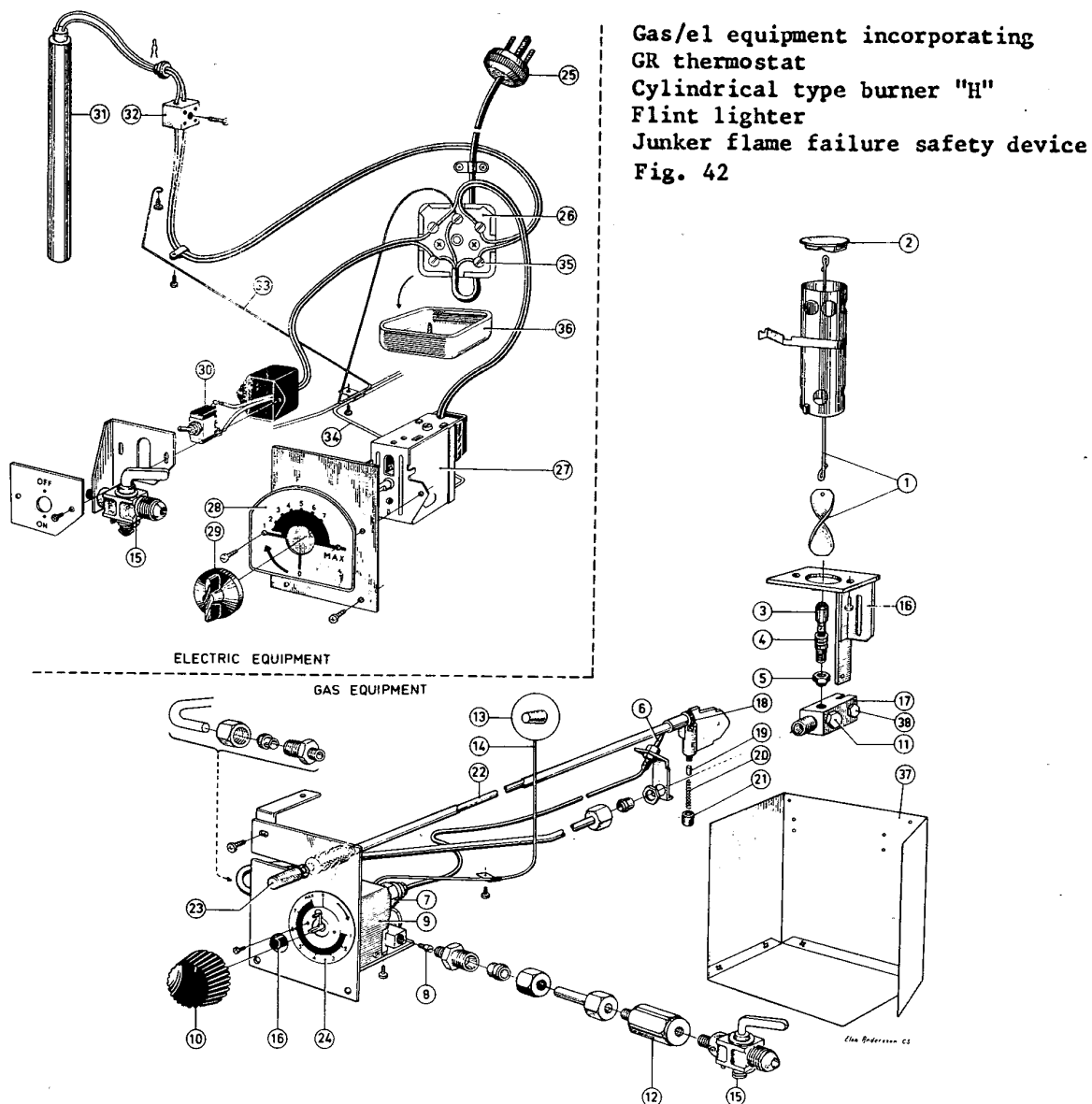
Gas equipment parts

- |                                     |                                     |
|-------------------------------------|-------------------------------------|
| 1. Flue baffle                      | 13. Cork plug for feeler tube inlet |
| 2. Flue top                         | 14. Thermostat feeler tube          |
| 3. Burner                           | 15. Gas cock                        |
| 4. Rings for primary air adjustment | 16. Push-button for lighting        |
| 5. Jet                              | 17. Burner base                     |
| 6. Safety valve feeler point        | 18. Lighter wheel                   |
| 7. Safety valve                     | 19. Lighter flint stone             |
| 8. By-pass screw                    | 20. Spring for lighter              |
| 9. Gas thermostat                   | 21. Screw cap for lighter           |
| 10. Thermostat knob                 | 22. Lighter shaft                   |
| 11. Pressure testing outlet         | 23. Turning knob for lighter        |
| 12. Gas filter                      | 24. Thermostat dial                 |
|                                     | 37. Burner protection cover.        |
|                                     | 38. Burner lock screw.              |

Electric equipment parts

- |                                 |
|---------------------------------|
| 25. Wall plug with earthing pin |
| 26. Junction box                |
| 27. Electric thermostat         |
| 28. Thermostat dial             |
| 29. Thermostat knob             |
| 30. Switch                      |
| 31. Heater                      |
| 32. Connector                   |
| 33. Earthing wire               |
| 34. Thermostat feeler tube      |
| 35. Terminal screws             |
| 36. Junction box cover          |

Fig. 42

Gas/el equipment incorporating  
 V-35 thermostat  
 Burner type "E"  
 Flint lighter  
 Junker flame failure safety device  
 Fig. 43

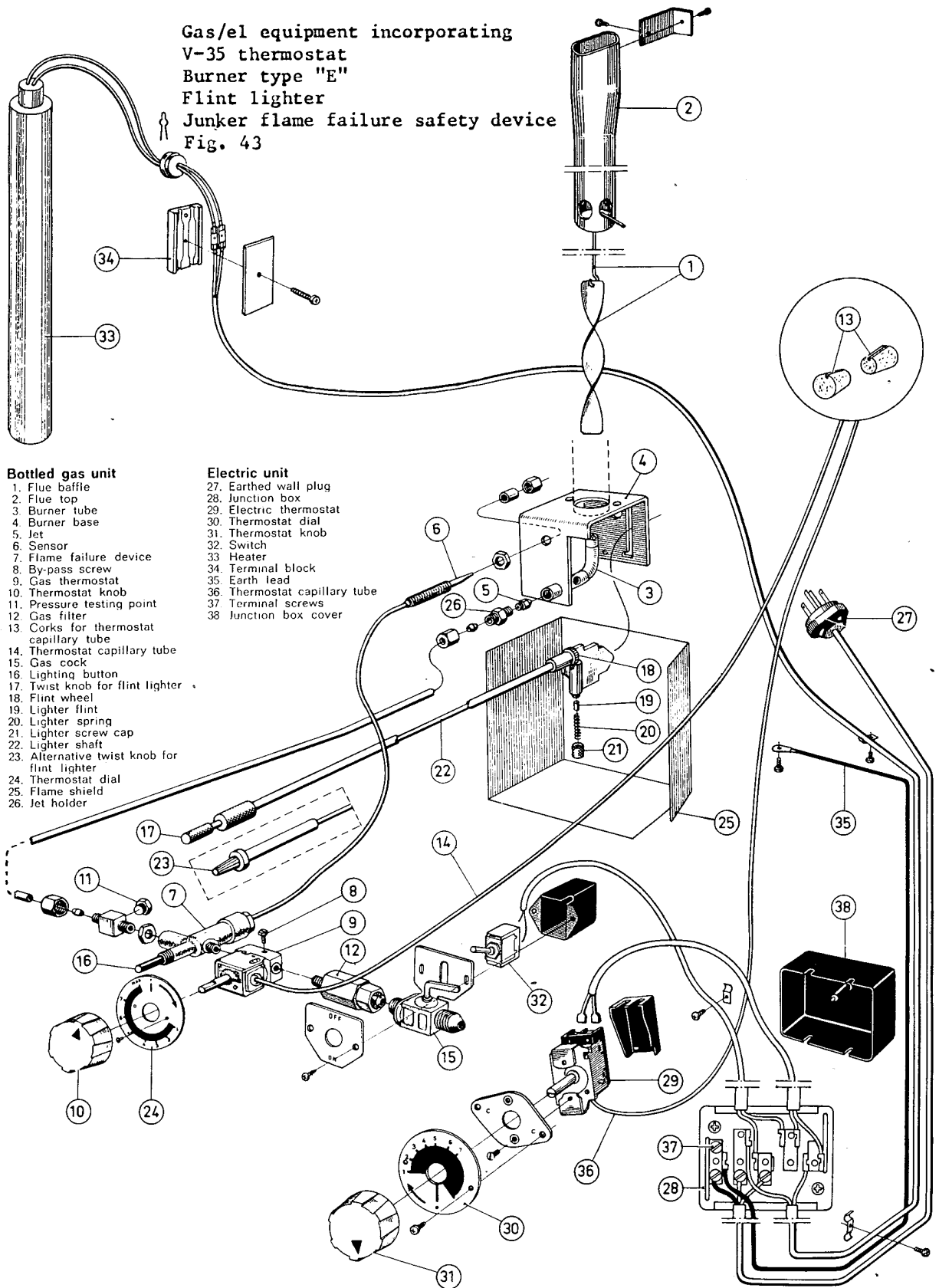

**Bottled gas unit**

1. Flue baffle
2. Flue top
3. Burner tube
4. Burner base
5. Jet
6. Sensor
7. Flame failure device
8. By-pass screw
9. Gas thermostat
10. Thermostat knob
11. Pressure testing point
12. Gas filter
13. Corks for thermostat capillary tube
14. Thermostat capillary tube
15. Gas cock
16. Lighting button
17. Twist knob for flint lighter
18. Flint wheel
19. Lighter flint
20. Lighter spring
21. Lighter screw cap
22. Lighter shaft
23. Alternative twist knob for flint lighter
24. Thermostat dial
25. Flame shield
26. Jet holder

**Electric unit**

27. Earthed wall plug
28. Junction box
29. Electric thermostat
30. Thermostat dial
31. Thermostat knob
32. Switch
33. Heater
34. Terminal block
35. Earth lead
36. Thermostat capillary tube
37. Terminal screws
38. Junction box cover

Fig. 43

### 39. GAS THERMOSTATS, JET AND BY-PASS SCREW TYPES USED IN DIFFERENT REFRIGERATOR MODELS

In par. 40, page 32 are listed:

1. Refrigerator models
2. Cooling unit types
3. Equipment designations
4. Gas thermostat type
5. Type and size of by-pass screw
6. Burner type
7. Jet size for butane and propane

The different types of gas thermostats used on Dometic refrigerators are as follows:

Type GDB fig. 16 and 17 (see page 14)

Type KCC fig. 21 (see page 16)

Type GR fig. 18 and 19 (see page 15)

Type V35 fig. 20 (see page 16)

The three different burner types used on Dometic refrigerators are as follows:

Type "B", which is a Bunsen type burner with ceramic head and ring and combined with the Klixon safety valve

Type "H" is the cylindrical burner with adjustable primary air inlets combined with the Junkers type thermoelectric flame failure safety device.

Type "E" This burner has the jet and jet adaptor horizontally located and the burner mixing tube is formed as a bend with vertical outlet. The primary air inlets are pre-set and therefore not adjustable. The tapping for the test gauge connection is located at an adaptor immediately downstream from the thermoelectric valve housing.

In the above mentioned burners different types of jets are used and in par. 41, page 33 the pertaining detail numbers of the jets are given.

In the above mentioned thermostats different types of by-pass screws are used and in par. 42, page 33 the pertaining detail numbers of the by-pass screws are given.

#### 40. Jet and by-pass screw sizes in different refrigerator models

Model	Cooling Unit Type	Equipment Designation	Thermostat Type	By-pass Screw Type	Burner Type	Jet size		
						Butane	Propane	Mixture
M16a,b	210A	16B2	GDB	A	B	35	40	37
M16c MC16a	210A	16B5	GDB	1	B	34	35	
MC16b	210A	16B12	GDB	2	B	34	35	
MC16c	210A	16B11	GR	1	H	41	44	
M27a,b,c	27A	27B1	GDB	A	B	37	40	
M27d	27A	27B4	GDB	1	B	35	37	
M28a	236A	28B1	GR	0	H	28	33	
		28B2	KCC	AD	H	28	33	
		28B3	V35	S17	H	28	33	
M28b	239A	28EB1	KCC	AD	H	33	36	
M28c	236A	28B4	V35	S17	E	27	29	
M28d	239A	28EB3	V35	S17	E	27	29	
MA35a	27A	27B4	GDB	A	B	35	37	
MA35b	27A	35B2	GDB	2	B	35	37	
MA35c	27A	35B1	GR	1	H	44	48	
MA35d	310A	35EB1	GR	1	H	44	48	
MA35f	310A	35EB2	KCC	K	H	44	48	
MA35g	27A	35B3	KCC	K	H	44	48	
MA40a	313A	40EB1	V35	S22	H	44	48	
MA40b	313A	40B1	V35	S22	H	44	48	
MA40c	313A	40EB2	V35	S22	E	32	38	
MKT500a,b	75A	723GD	GDB	B	B	46	48	47
	75A	50B2	GDB	B	B	46	48	
M50a	75A	50B4	GDB	2	B	46	47	
M52a	53A	52B1	GDB	1	B	40	42	
M52b	53A	52B3	GDB	2	B	40	42	
M52c,f	510A	52B2	GR	1	H	57	62	
M52d,e	510A	52EB1	GR	1	H	57	62	
MA52a	510A	52EB2	KCC	K	H	57	62	
MB52a	510A	52EB3	V35	S22	H	57	62	
MB52b	510A	52EB4	V35	S22	E	43	52	
M70a	512A	70EB1	KCC	K	H	62	72	
M70b	512A	70EB2	V35	S22	H	62	72	
M70b	512A	70EB3	V35	S22	E	51	53	

**41. Jet sizes and pertaining detail numbers for gas burner types B, H and E**

Burner type B		Burner type H		Burner type E	
Jet size	Detail number	Jet size	Detail number	Jet size	Detail number
34	166060	28	169360	26	173345
35	166580	33	169356	27	173345-01
37	159888	34	169357	28	173345-02
40	64581	36	169358	29	173345-03
42	156564	41	169350	30	173345-04
45	64582	44	169351	31	173345-05
46	64583	48	169352	32	173345-06
47	156565	57	169353	38	173345-07
48	64584	62	169354	39	173345-08
49	156566	67	169355	43	173345-09
50	61667	72	169359	51	173345-10
				52	173345-11
				53	173345-12

**42. By-pass screw types and pertaining detail numbers**

Type	Detail number	
0	172122	
1	166061	
2	166062	
A	270585	
AD	172820	
B	270586	
K	293913	
S17	172819-02	
S22	172819-01	
S38	172819-00	



**41. Jet sizes and pertaining detail numbers for gas burner types B, H and E**

Burner type B		Burner type H		Burner type E	
Jet size	Detail number	Jet size	Detail number	Jet size	Detail number
34	166060	28	169360	26	173345
35	166580	33	169356	27	173345-01
37	159888	34	169357	28	173345-02
40	64581	36	169358	29	173345-03
42	156564	41	169350	30	173345-04
45	64582	44	169351	31	173345-05
46	64583	48	169352	32	173345-06
47	156565	57	169353	38	173345-07
48	64584	62	169354	39	173345-08
49	156566	67	169355	43	173345-09
50	61667	72	169359	51	173345-10
				52	173345-11
				53	173345-12

**42. By-pass screw types and pertaining detail numbers**

Type	Detail number	
0	172122	
1	166061	
2	166062	
A	270585	
AD	172820	
B	270586	
K	293913	
S17	172819-02	
S22	172819-01	
S38	172819-00	

PRESSURE MEASURING DEVICES

**43. Water U gauge**

The water gauge consists of a glass U tube filled to mid-point with water. When gas pressure is exerted on one side of the gauge, the water on that side is forced down and there is a corresponding rise of water on the other side.

Water column pressure per square inch is indicated by the difference of the two columns of water measured in inches.

A convenient scale reading in inches and tenths of an inch is mounted between the two columns.

When reading the gauge proceed as follows:

If the gauge is filled with water to zero and the lower column is 5.5 inches below zero, the other column will also be 5.5 inches. By adding the two together  $5.5 + 5.5 = 11$  inches water column.

For accuracy of measurement a water U gauge is far superior to a low pressure gauge. If a low pressure gauge is used, it should be checked for accuracy against a water U gauge occasionally.

**44. Low pressure gauge (Fisher)**

This gauge is calibrated to read in "inches of water column pressure". It is a standard manometer reading and is colored red.

How to use the pressure gauge

Fig. 45 shows the Fisher low pressure gauge and the water U gauge.

When testing the pressure on the different burners, remove the plug indicated with an arrow in fig. 45 and fit the hose from the pressure gauge. It is very important that the gas operated refrigerators operate at correct pressure, i.e. at the pressure stipulated for the refrigerator.

The pressure of the burner should be checked at the time the refrigerator is started up. After connecting the pressure gauge, set the thermostat dial at "MAX". Turn on the gas at the union cock and light the burner. At the "MAX" setting the pressure reading should be at a minimum  $10 \frac{1}{2}$ " or a maximum of  $11 \frac{1}{2}$ " if the L.P. gas is supplied directly to the thermostat from the regulator fitted on the gas bottle at pressure of 11".

Refrigerators provided with gas equipments 16 B2, 27 B1, 50 B2 and 723 GD1 require a pressure of 7" - 8", which is obtained by a special regulator (fig. 44) incorporated in those equipments, see fig. 40, page 27. At the "MAX" setting the pressure reading should be at a minimum  $7 \frac{1}{2}$ " or a maximum of  $8 \frac{1}{2}$ " water column.

(Cont. page 36)

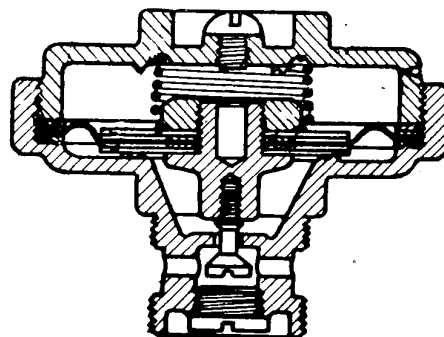
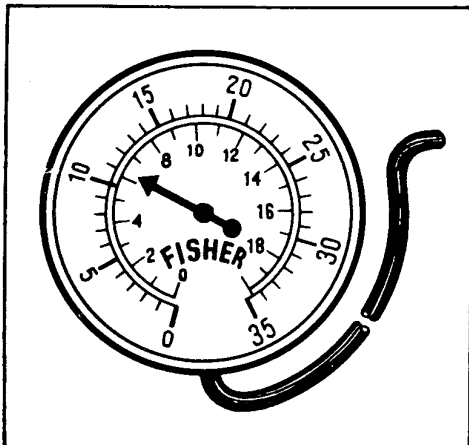
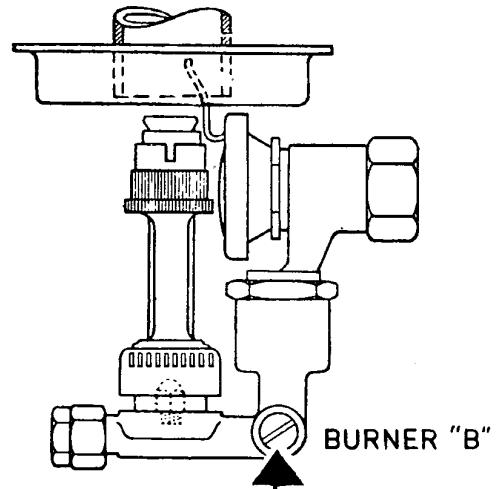
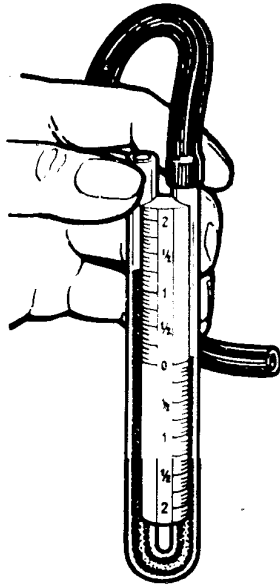

Fig. 44

WATER U GAUGE



LOW PRESSURE GAUGE

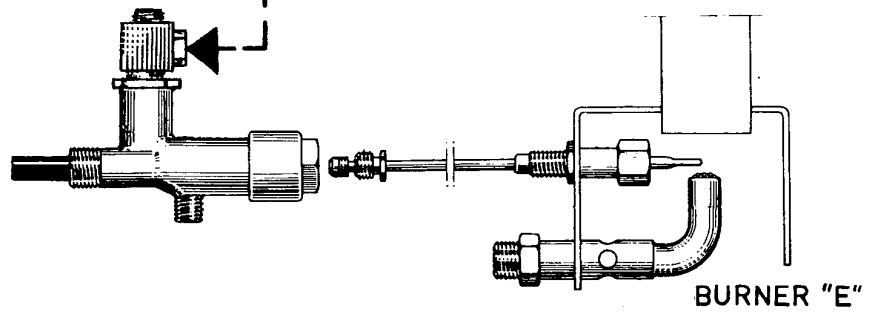
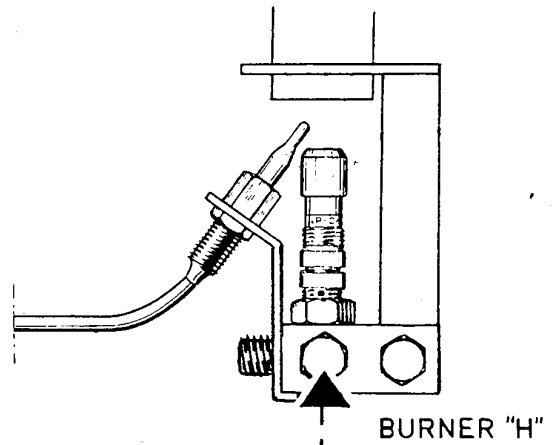

Fig. 45

When testing the by-pass pressure the thermostat should be set at "0". With the thermostat at "0" the pressure should be within the range given in par. 45.

**45. BY-PASS PRESSURES AT THERMOSTAT SETTING "0" ON GAS EQUIPMENTS PROVIDED WITH 8" W.C. PRESSURE REGULATOR**

Equipment designation	Thermostat model	By-pass screw	Jet size	Burner type	Pressure at test point in W.C.
16 B2	GDB	A	40	B	0.6 - 1.8
27 B1	GDB	A	40	B	0.6 - 1.8
50 B2	GDB	B	48	B	0.4 - 1.4
723 GD1	GDB	B	48	B	0.4 - 1.4

If the pressure supplied to the thermostat is 11" W.C. and the thermostat dial is set on "0" the following "by-pass" pressures can be measured. The pressure depends not only on the size of by-pass screw but also on the size of burner jet. Since there are variations in screws and jets and small seepages through the thermostat valve the pressure figures are given within the range.

**46. By-pass pressures at thermostat setting "0" when the gas pressure supplied to thermostat is 11" W.C.**

Thermostat model	By-pass screw	Jet size	Burner type	Pressure at test point in. W.C.	
GR 15	0	28	H	4.2 - 5.3	
		33		4.0 - 5.1	
	1	41	H	3.0 - 4.2	
		44		2.6 - 3.7	
		48		2.2 - 3.3	
		57		1.8 - 3.0	
Teddington KCC	AD	62		1.4 - 2.5	
		28	H	4.2 - 5.3	
		33		4.0 - 5.1	
		36		3.5 - 4.7	
		K	44	H	2.6 - 3.7
			48		2.2 - 3.3
57			1.8 - 3.0		
62			1.4 - 2.5		
		72		1.0 - 2.2	

(cont.)

(cont.)

Thermostat model	By-pass screw	Jet size	Burner type	Pressure at test point in. W.C.
Ranco V35	S17	28	H	6.7 - 7.5
		33		6.5 - 7.3
		36		6.3 - 7.1
	S22	44	H	5.7 - 6.5
		48		5.5 - 6.3
		57		4.7 - 5.5
		62		4.3 - 5.1
		72		3.5 - 4.3
	S17	27	E	6.7 - 7.5
		29		6.5 - 7.3
	S22	32	E	5.9 - 6.7
		38		5.5 - 6.3
		43		4.7 - 5.5
		51		4.3 - 5.1
		52		4.2 - 4.9
53		3.7 - 4.5		

#### 47. ELECTRIC OPERATION

The electric installation in combined gas/electric equipments is shown in the exploded views on pages 29 and 30. The electric installation for dual voltage operation is shown in fig. 46. At the cable connection to the two-voltage change-over switch there is no need to pay attention to positive or negative poles. The cable for the connection to the electricity supply point is delivered with the cabinet and connected to the 110 V terminals.

The thermostat is connected so as to serve both voltage circuits. The heating element (7, see fig. 46) contains two heating coils, one for 12, 24, 32 V respectively and one for 110 V.

#### 48. How to set the refrigerator for battery alternatively 110 V operation

(see fig. 46, page 38)

Inside the shutter below the cabinet door you will find the two-voltage change-over switch (2) for battery alternatively 110 V operation. The switch knob has a lengthwise line marking which points at 0 when the current is switched off. When the line marking points at the position 1 the battery or generator current is switched on and when the line points at 2 the 110 V current is on.

1. Check that the refrigerator is connected to the electricity supply point and that the current is on.
2. Turn the thermostat knob (4) to setting 3 or 4. After about an hour the refrigerator will commence to cool.

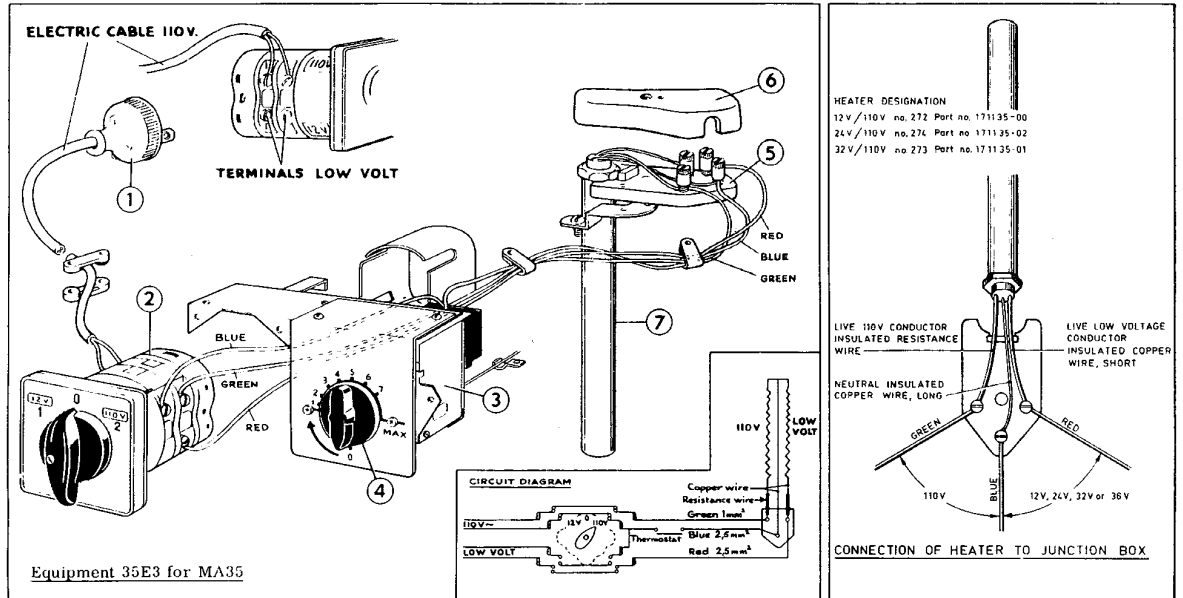

1. Wall plug
2. Two-voltage change-over switch
3. Thermostat
4. Thermostat knob
5. Junction box
6. Junction box cover
7. Two-voltage heater

This electrical equipment is specially designed for refrigerators installed on board ships. With a switch the cooling unit can be set for battery operation while at sea or, alternatively, 110 V operation while in port.

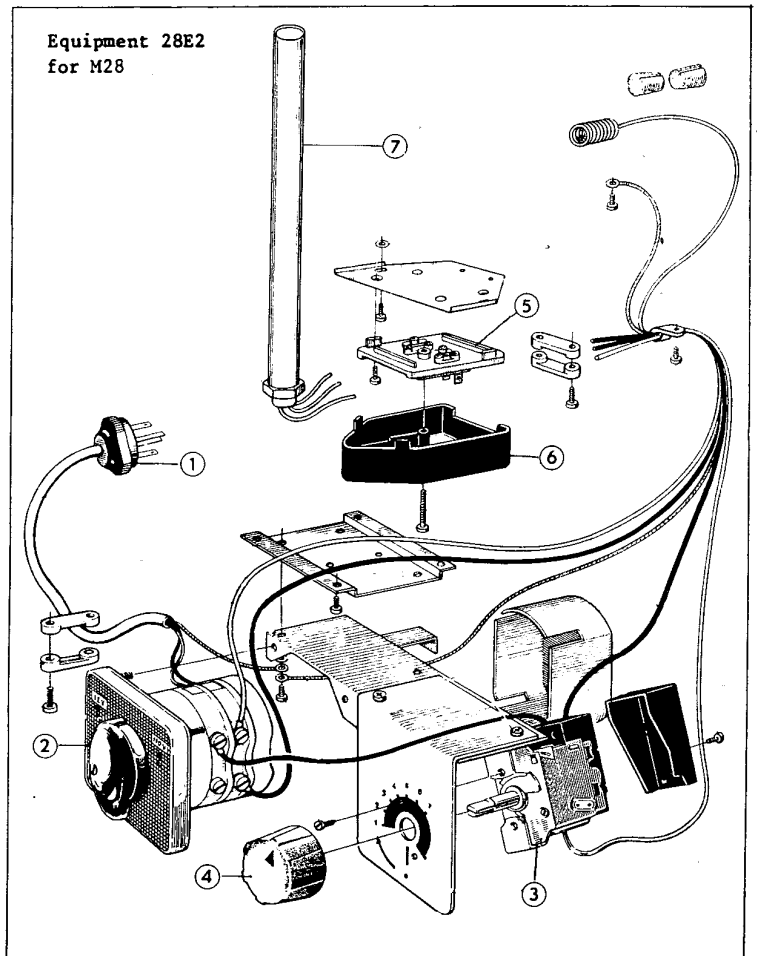
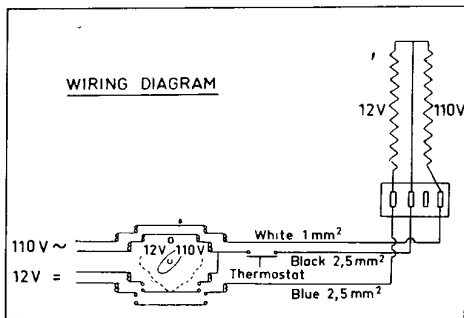

Fig. 46

#### 49. REPLACEMENT OF HEATING ELEMENT IN GAS/EL REFRIGERATORS

On the gas/electric operated refrigerators heat is supplied by an electric heater (A) mounted on the cooling unit inside the insulated cover (B). See fig. 47.

The heater is accessible for replacement after removal of shutter (C) and the rock-wool insulation.

- 1) Check that the size and wattage of the heater are correct for the unit.
  - 2) Check that the supply voltage corresponds to the voltage stamped on the heating element.
  - 3) Make sure that the heater is inserted to its full length in its pocket.
  - 4) Lock the heater in position by means of the hook on the heater pocket. See fig. 48.
  - 5) Be careful to put the insulation in its proper place again after replacement.
- Note: The edges of the opening in the cover may be sharp!

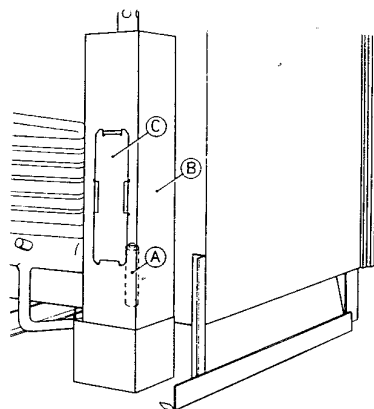

Fig. 47

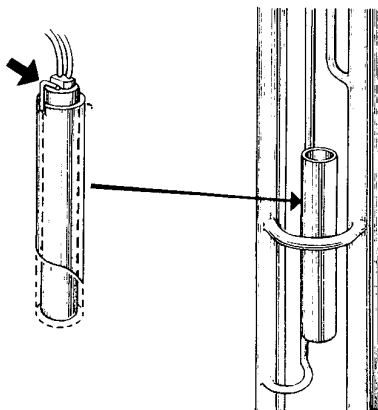

Fig. 48

## 50. SERVICE HINTS FOR ELECTRIC OPERATED REFRIGERATORS

<u>Cause</u>	<u>Remedy</u>
<u>a. The refrigerator does not cool satisfactorily.</u>	
Thermostat at wrong setting.	Turn the thermostat dial to a higher number.
Air circulation over cooling unit restricted.	Remove any restriction. The minimum clearance stated in par. 6 for air circulation must be allowed.
Refrigerator not level.	The refrigerator must be level in both directions to operate properly. If in a caravan, always make sure it is level when parked. See par. 53.
Air leakage into cabinet.	Check fit of door gasket, and that the sealing plug is in the hole for the thermostat capillary in the rear wall of cabinet. See par. 61.
Evaporator heavily coated with frost.	If the cooling unit is not equipped with the automatic defrosting device defrost at more frequent intervals. Also see par. 56d and 61.
Heater faulty, wrong voltage or type.	Fit a new heater of appropriate voltage (see par 51).
Intermittent electricity supply.	Look for loose connections or other reason for interruption, and correct.
Drop in supply voltage.	The supply voltage should be maintained at the full rate.
Thermostat at "0".	Turn thermostat dial to No. 3 or 4.
Break in electrical circuit.	Check fuses, switches, wiring etc., and repair the fault.
Heater faulty (open circuit).	Fit a new heater (see par. 51).
Thermostat faulty.	Have a new thermostat fitted.
<u>b. The refrigerator is too cold.</u>	
Thermostat at wrong setting.	Turn the thermostat dial to a lower number.
Spiral of thermostat capillary incorrectly located.	Re-insert the spiral fully in the special pocket under the ice-tray compartment. See par. 55.
Thermostat faulty.	Have new thermostat fitted.
Heater wrongly connected to terminal block.	See diagram in spare parts list.



**51. Electric equipment and heating elements for different refrigerators**

Cabinet Type No.	Equipment Type No.	Cooling Unit Type No.	Type	Volts	Watts	D mm	L mm	Detail No.
M28	28E2E4	239A2		12/110	115	15.0	245	17 33 37-02/3
M28b	28EB1	239A1		110	115	15.6	109	17 31 21-01/3
M28d	28EB3	239A1		110	115	15.6	109	17 31 21-01/3
MA35d	35EB1	310A1	310	110	135	17.5	163	17 06 77-01/7
MA35f	35EB1	310A1	310	110	135	17.5	163	17 06 77-01/7
MA35b	35E3	310A1	272	12/110	150	21.8	213	17 11 35-00/7
MA35b	35E3	310A1	274	24/110	150	21.8	218	17 11 35-02/3
MA35b	35E3	310A1	273	32/110	150	21.8	218	17 11 35-01/5
MA40a	40EB1	313A1	310	110	135	17.5	163	17 06 77-01/7
MA40c	40EB2	313A1	310	110	135	17.5	163	17 06 77-01/7
M52d	52EB1	510A1	511	110	225	15.6	180	17 06 79-01/3
M52e	52EB1	510A1	511	110	225	15.6	180	17 06 79-01/3
MA52a	52EB3	510A1	511	110	225	15.6	180	17 06 79-01/3
MB52c	52EB4	510A1	511	110	225	15.6	180	17 06 79-01/3
M70a	70EB2	512A1	512	110	225	17.5	160	17 30 74-01/4
M70b	70EB3	512A1	512	110	225	17.5	160	17 30 74-01/4

**52. Amperage figures on rating plates**

Model	Voltage	Ampere	(Voltage Ampere)		
M28	110	1.1	12	9.6	x)
MA35	110	1.3	12	11.7	x)
MA40	110	1.3			
MA/MB52	110	2.1			
M70	110	2.1			

x) not on the rating plate

---

SERVICE MAINTENANCE

**53. Leveling**

In the boiler of the cooling unit, ammonia vapor is distilled from an ammonia-water mixture and carried to the finned condenser where it liquefies. The liquid flows to the evaporator inside the cabinet where it creates cold by evaporating into a circulating flow of hydrogen gas. If the evaporator is not level the liquid readily accumulates forming pockets which can impair the gas circulation or block it completely, in which case, of course, cooling will stop.

When the trailer is stationary it must be leveled to be comfortable to live in. If the refrigerator is properly installed, i.e. the ice-tray compartment shelf is parallel with the floor, the refrigerator will operate properly. To check this, a bubble level is supplied with the refrigerator. The level should be placed on the ice-tray compartment shelf and the position of the bubble observed (if necessary, with the aid of a small mirror). Adjust the position of the trailer so that the bubble is in the center ring of the level.

When the trailer is on tow, the continuous rolling and pitching movement will not affect the refrigerator as long as the movement passes either side of level but when the trailer is temporarily parked, the sensitivity of the refrigerator should be remembered.

**54. Temperature control (thermostat)**

- a) When the temperature control (thermostat) is set at a higher step, refrigerating effect will be increased. This will tend to lower the temperature in the freezing compartment and in the food storage compartment.

When the temperature control is set at a lower step, refrigerating effect will be reduced.

When the temperature control is set at mid-dial position, medium refrigerating effect will be produced.

- b) The position of the temperature control should depend upon the refrigerator load. When the food load is heavy, turn the temperature control to a higher step. A higher setting of the temperature control will be required in summer than in winter.

The setting of the temperature control determines the action of the thermostat in relation to freezing compartment temperatures.

**55. The thermostat bulb**

At the bottom of the freezing compartment is a sleeve in which the spiral end of the thermostat sensitive tubing must be inserted. If the spiral end (bulb) is not properly inserted in its sleeve, the burner will operate continuously at maximum flame. It will cause too low cabinet temperatures.

## 56. Storing food in the refrigerator

- a) Proper refrigeration requires free air circulation within the food storage compartment. Restricted air circulation within the food storage compartment will cause higher cabinet temperatures. Rearrange foods.
- b) It is also essential that the shelves are not covered with paper or large storage containers.
- c) Odorous foods or highly flavored foods should always be stored in covered dishes, plastic bags or wrapped in foil or waxed paper, to prevent food odors. Vegetables, lettuce, etc., should be covered to retain their crispness. Never put hot food into the refrigerator.
- d) To reduce frost formation in and on the freezing compartment, cover stored liquids and moist foods and do not leave the door open longer than necessary.
- e) When the refrigerator is heavily loaded, it takes longer for refrigerator temperatures to lower, also increasing the ice making time. A very heavy load may also cause defrosting.

## 57. Cleaning

The cabinet interior should be cleaned regularly. Remove the shelves and wash the lining with lukewarm water to which a little soap flakes may be added. Dry thoroughly, especially around door frames and door gasket. Warm water only should be used to wash the cooling evaporator, ice-trays and shelves.

Plastic dishes may be washed in warm soapy water - not hotter than is bearable to the hand. Do not expose them to dry heat. (Never use strong chemicals or abrasive cleaning materials on any part of the cabinet.)

## 58. Ice cubes

- a) Do not use warm water, as it takes longer to freeze.
- b) Faster freezing will result if precooled water is used.

## 59. Travel lock

The travel lock pin may be fitted to hold the door closed whilst in transit.

## 60. To shut off the cabinet

If for any reason refrigeration is not required over a period of weeks, the gas taps or electric switch should be turned off.

The cabinet and ice trays should be emptied, cleaned and dried and the door left ajar.

## 61. Door seal

- a) It is essential, for correct operation, that the door gasket makes a good seal all around, against the front of the cabinet.

The compression of the gasket down the hinge side must not be too great: The gasket should just contact the front of the cabinet when the door is closed. This is normally allowed for during manufacturing.

Failure of the door gasket to contact the front of the cabinet can be determined visually when the door is closed. Run a piece of thin cardboard along the door seal, inserted between the seal and the cabinet front. Nowhere should the card feel loose.

Improper door pressure on cabinets provided with rubber gaskets can be corrected by adjusting the door latch striker or the hinges.

- b) Improper door sealing on cabinets provided with magnetic door gasket can be corrected by slackening the upper and lower hinge fixing screws and moving the door inwards or outwards as required until a satisfactory seal is obtained.

If a good seal cannot be obtained, a new gasket should be fitted.

- c) It is also essential to check that the cabinet opening through which the freezing compartment enters the cabinet should be properly sealed by a gasket or sealing compound. If these seals leak, warm air enters the cabinet causing high cabinet temperatures and excessive frost formation on the freezing compartment.

## 62. Flue obstructions

On gas refrigerators, the flue will require cleaning occasionally. To do this it will be necessary to gain access to the back of the cabinet. When cleaning the flue proceed as follows:

Unscrew the burner and the jet. Cover the hole in the burner base with a piece of rag, then lift out the baffle on its support wire from the top of the boiler tube.

From the top, clean the flue with a suitable flue brush. Also clean the baffle, before putting back in place.

An obstruction in the flue will reduce or stop flue draft. Flue obstructions will cause odors outside refrigerator, slow freezing and higher cabinet temperatures. Flue stoppages may also cause the flame to burn outside the central tube.

## 63. Odors inside the refrigerator

Odors inside the refrigerator are caused by improper food storage (see par. 56c, page 43).

They may also be caused by too infrequent cleaning of the food compartment or the refrigerator has been shut off for some time with the door closed.

## 64. Odors from fumes

- a) Odors outside the refrigerator may be caused by gas leaks. Make sure that all burner gascocks on all gas appliances are closed. Test gas connections and all joints in the gas line with soap and water solution, up to and including gas cock. Never look for a leak with an open flame. Use a flashlight when necessary in looking for soap bubbles caused by leaks. The gas line should be free of kinks and sharp ends.

Turn on gas cock, light burner and test connections between the gas cock and the burner carefully with soap and water.

- b) Odors outside the refrigerator may be caused by improper burner flame.
- c) The flame touches side of the boiler due to dislocation of the burner. Relocate. Burner dislocation may also cause smoke and discolouring of walls and ceiling.

- d) Burner damaged. Replace.
- e) The flame touches flue baffle. Correct position of baffle.
- f) The flue tube is dirty. Clean the flue.

### 65. Flame blows out

If trouble is encountered with the flame blowing out under specially windy conditions, try to place the vehicle so that the wind does not blow directly into the vent outlets. If the trouble persists, set the thermostat on "MAX". This latter measure can of course only be temporary such as when the caravan is on tow, for after several hours at this setting the foodstuffs in the cabinet may become too cold.

### 66. Lost thermostat charge

If the thermostat control assembly loses its charge, it will become inactive. To test for a lost charge, while the flame is reduced to minimum and the temperature control is set at a numbered position on its dial: Remove thermostat bulb from bulb sleeve in the evaporator and warm bulb with the hand. If the flame fails to increase in size, the thermostat has lost its charge and the thermostat must be replaced.

### 67. The flint lighter (see fig. 49)

A new flint will be required from time to time, and to fit one the lighter must be removed by loosening the lock nut (1) located on the inside of the front plate. The lock nut is turned clockwise, thus releasing the squeeze pressure holding the lighter in position. The lighter can then be taken out from under the refrigerator and the flint stone be replaced.

Unscrew the cap (2), pull out the spring (3) and tap out any piece of flint remaining. Put in a new lighter flint (4) and insert the spring (3). Screw on the cap (2).

Replace the lighter with the spring cap pointing downwards and the tongue (5) entering the slot in the back of the burner holder. When returning the lighter to its working position, be careful not to tighten the lock nut (1) too hard. The turning of the lighter knob might then become inconvenient or even impossible.

Make quite sure the tongue is properly located in the slot in the burner holder and test the lighter to see that it works properly. See fig. 42 and 43, pages 29 and 30.

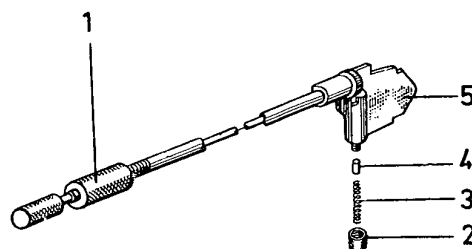

Fig. 49

**68. Changing the door panel**

Unscrew the upper hinge pin (1, fig. 50). Remove the hinge pin and lift off the door. Back off the screws holding the lower aluminium trim moulding (5) in place. Withdraw the door panel (6), reverse it and reassemble, finally fitting trim moulding and door back in position.

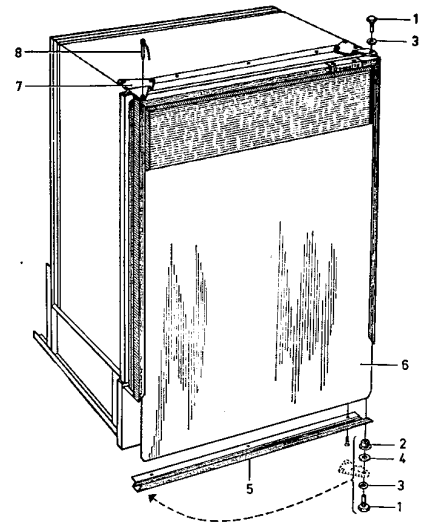

Fig. 50

**69. Changing door opening from left to right**

Unscrew the hinge pins (1, fig. 50). Transfer the nylon bushing (2) and washers (3, 4) in the right order to the opposite side. Then fit the hinge pins to the opposite hinge plate (7). Transfer the locking pin (8) and chain, used when the caravan is in motion, to the opposite hinge plate.

Afterwards, check that the door closes easily and that it makes a good seal all the way round. If necessary, adjust the hinge plates.

**To change the door colour (fig. 51)**

First unscrew the locking nut (1) at the lower end of the long hinge pin (2). To prevent the pin from turning, insert a narrow screwdriver through the locking nut and into the slot provided in the threaded end of the hinge pin. Pull out the pin and lift off the door. Remove the name plate using a Philips head screw driver for the screws. Remove the screws holding the bottom aluminium door frame (3). Pull out the outer door panel (4), reverse panel and assemble. Finally screw the name plate back in position and refit the door.

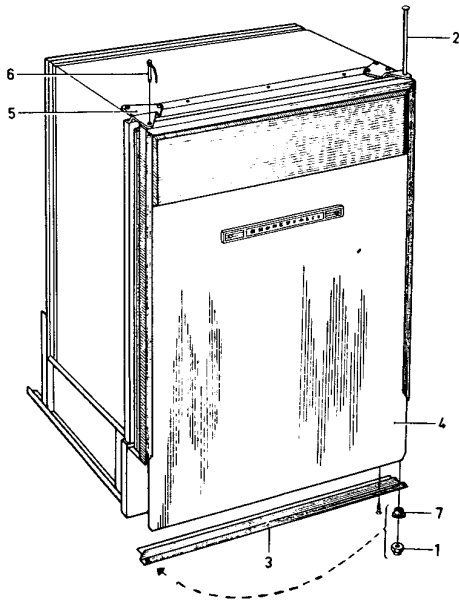

Fig. 51

**To change the door opening from left to right or vice versa (fig. 51)**

First unscrew the locking nut (1) as described above. Pull out the pin (2) and transfer the nylon bushing (7) to the opposite end of the bottom door frame. Insert pin through the opposite hinge (5), push pin right through and see that the pin engages the lower hinge. Screw the locking nut (1) back on to the hinge pin. The small hinge pin (6) with chains is then transferred to the opposite top hinge to be used for securing the door during travelling.

Check that the door closes easily and that the gasketed seals well on all sides. If necessary, adjust by resetting the top hinge.

## 70. OPERATION ANALYSIS FOR COOLING UNIT

It is obviously important that all external factors affecting the unit should be checked properly before a unit is condemned as faulty and that emphasis has been placed upon the necessity for correct installation, upright refrigerator, correct heat input, baffle position, etc. If the refrigerator is the gas/electric model, check the size and the wattage of the electric heater and make sure that the heater element is inserted to its full length in its pocket or receptacle. See fig. 43, page 39. If the electric heater is only partly inserted, the heat distribution will be incorrect, causing an excessive vaporizing of the ammonia within the boiler when operating on electricity. The same symptom can show up with too much or too little heat input either on electric or on gas operation and also if the refrigerator had been operating in an off-level position or with inadequate ventilation.

If an excessive vaporizing of the ammonia within the boiler occurs due to the reasons above, the liquid mixture in the boiler becomes very weak and the pump will cease to operate, which means that the circulation of liquid stops with the result that the evaporator inside the cabinet ceases to produce cooling.

Such a blockage of the unit in the liquid circuit is most usually made evident by signs of overheating on the vapour pipe leading from the boiler to the condenser, the paint on this pipe being blistered and the metal becoming discoloured.

To remedy this fault it is recommended to remove the unit or refrigerator complete whenever possible and to allow sufficient time to cool down the unit. Turn the unit or refrigerator upside down several times, so that the liquid in the absorber vessel can be mixed with the liquid in the boiler. This procedure will restore the liquid balance in the unit. Start the unit on "MAX."

The temperatures on various parts of a unit vary continuously when it is operating on thermostatic control and it is impossible to base a judgment on the symptoms given unless the refrigerator has been operating continuously on fully correct heat input for at least 5 hours, and preferably 12 hours, prior to examination. In many cases this can be arranged by a telephone call to the customer, asking him to switch the thermostat to "MAX." on the day before the inspection call. If after 12 hours' operation on "MAX." the performance is satisfactory, the unit is not at fault unless the complaint is one of varying or intermittent performance. In this connection the room temperature at the time of the complaint must be considered, as a unit which is satisfactory at an ambient temperature of 50°F may not be satisfactory at 95°F.

In cases where satisfactory performance is obtained on "MAX." but not on other settings, the thermostat is to be suspected.

When a normal unit is working on "MAX." the absorber coil will be warmer at the bottom than it is at the top. The absorber vessel will be warmer. The vapour cooling pipe from the boiler to the condenser will be warm, bearably to the hand, at the bend where it joins the condenser, with a gradual rise in temperature towards the boiler end.

## 71. Unit filling valve

The needle valve used for admitting the filling charge to a cooling unit is fitted to the unit's absorber vessel and is covered by an aluminium or plastic cap. It is strictly applied provision of the warranty extended on the unit to the customer, that any interference with the filling valve will automatically void the warranty.

Unsatisfactory unit performance due to an ammonia leak can be determined in the case of a visible leak by traces of a yellow deposit at the point where the ammonia is escaping. If there is a leak on the evaporator inside the cabinet, a smell of ammonia may be noticeable.

---

**72.** There are many things to consider before determining that the unit is faulty.

1. Leveling of the refrigerator
2. Ventilation
3. Cleaning and proper size of burner orifice
4. Cleaning and proper size of by-pass screw
5. Cleaning of thermostat valve
6. Correct burner air adjustment
7. Proper gas pressure
8. Correct height of flame
9. Correct position of baffle in boiler tube
10. No burnt-out heating element
11. Heating element in correct position
12. Correct size and wattage of heating element
13. Supply voltage corresponds to voltage stamped on heating element
14. No fluctuation in voltage supply
15. No loose electric connections
16. Thermostat intact
17. No unit leaks

**73.** PACKING OF DEFECTIVE UNITS

Particular attention must be paid to the packing of a replaced defective unit to ensure during its return to the distributor, that it will not be damaged in transit.

When the replacement unit is supplied cased, careful note should be taken of the manner in which it is packed, to ensure that the form of packing adopted, i.e. the use of wood bracing and cardboard pads, is used when the defective unit is packed into the case.

Structural distortion, particularly with the smaller units not having an angle iron frame, can easily occur if the case containing the unit is roughly handled and if internal braces are not in position.



74. OPERATION ANALYSIS FOR REFRIGERATORS OPERATING ON ELECTRICITY

SYMPTOM					CAUSE	
Refrigerator too cold	Refrigerator not cold enough	No refrigeration	Frost forms rapidly	Odour inside cabinet	See paragraph No.	Note: It will be noted in this tabulation that several causes can be responsible for the one effect. The real cause or causes should be determined by a process of elimination, investigating each possible cause, starting at the top of the tabulation and proceeding to the bottom.
	x	x			6	Not adequate ventilation
	x	x			53	Refrigerating unit not level
	x	x			50a, 51	Heater faulty, wrong voltage or type
	x	x			50a	Voltage not constant
		x			50a	Electric connections loose
	x	x			49	Heater not inserted correctly in its pocket
	x	x			56a, b	Improper food storage
x	x	x			54	The thermostat incorrectly used
			x		56d, 61	Improper storage of liquids and moist foods
	x	x	x		61	Leaky cabinet seals
				x	57	Infrequent cleaning of food compartment
				x	60	Refrigerator shut off with closed door
				x	56c	Unwrapped odorous food
x			x		55	Incomplete contact of thermostat bulb
	x	x			66	Lost thermostat charge
	x	x			70, 72	Failed refrigerating unit
x					54	Room temperature too low

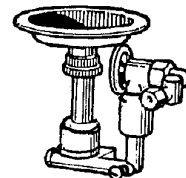

### 75. OPERATION ANALYSIS FOR LP GAS REFRIGERATORS WITH BURNER "B"

SYMPTOM							CAUSE	
Refrigerator too cold	Refrigerator not cold enough	No refrigeration	Frost forms rapidly	Burner flame goes out	Odour inside cabinet	Odour outside cabinet		
							See paragraph No.	Note: It will be noted in this tabulation that several causes can be responsible for the one effect. The real cause or causes should be determined by a process of elimination, investigating each possible cause, starting at the top of the tabulation and proceeding to the bottom.
						x	8, 64	Gas leaks
	x	x					6	Not adequate ventilation
	x	x					53	Refrigerating unit not level
	x	x		x			21	Jet orifice clogged
	x	x		x			16, 18, 19, 29	Klixon tongue not in correct position
	x	x		x			17	Improper maximum flame
	x	x		x			20	By-pass flame too small
	x	x		x			22	Gauze in burner head clogged
x			x				15	Dirt in thermostat or valve seat
x			x				15, 23	By-pass flame too large
	x	x		x			36, 37	Improper position of the flue baffle
	x	x					20, 21, 22	Unstable burner flame
	x	x					56a, b	Improper food storage
x	x	x					54	The thermostat incorrectly used
			x				56d, 61	Improper storage of liquids and moist foods
	x	x	x				61	Leaky cabinet seals
	x	x	x			x	62	Obstructed flue
					x		57	Infrequent cleaning of food compartment
					x		60	Refrigerator shut off with closed door
					x		56c	Unwrapped odorous food
						x	64	Flame contacts central tube
						x	18	Insufficient primary air
x			x				55	Incomplete contact of thermostat bulb
	x	x					66	Lost thermostat charge
							70, 72	Failed refrigerating unit
x							54	Room temperature too low



Burner type "H"

## 76. OPERATION ANALYSIS FOR LP GAS REFRIGERATORS

WITH BURNERS "H" AND "E"

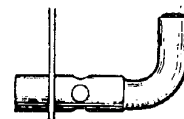

Burner type "E"

SYMPTOM							CAUSE			
Refrigerator too cold	Refrigerator not cold enough	No refrigeration	Frost forms rapidly	Burner flame goes out	Odour inside cabinet	Odour outside cabinet	See paragraph No.	Note: It will be noted in this tabulation that several causes can be responsible for the one effect. The real cause or causes should be determined by a process of elimination, investigating each possible cause, proceeding to the bottom.		
						x			3, 64	Gas leaks
	x	x							6	No adequate ventilation
	x	x							53	Refrigerating unit not level
	x	x		x					26	Jet orifice clogged
				x					52	The thermocouple tip not in position
				x					52	No contact between thermocouple and safety valve magnet
				x					35	Faulty safety valve magnet
	x	x							26, 40	Improper maximum flame
	x	x		x					40	By-pass flame too small
	x	x		x			26	Gauze in burner head clogged		
x			x				14	Dirt in thermostat or valve seat		
x			x				14, 40	By-pass flame too large		
	x	x		x			36, 37	Improper position of the flue baffle		
	x	x					26, 45, 46	Unstable burner flame		
	x	x					56a, b	Improper food storage		
x	x	x					54	The thermostat incorrectly used		
			x				56d, 61	Improper storage of liquid and moist foods		
	x	x	x				61	Leaky cabinet seals		
	x	x	x			x	62	Obstructed flue		
						x	64	Flame contacts central tube		
						x	25	Insufficient primary air		
					x		57	Infrequent cleaning of food compartment		
					x		60	Refrigerator shut off with closed door		
					x		56c	Unwrapped odorous food		
x			x				55	Incomplete contact of thermostat bulb		
	x	x					66	Lost thermostat charge		
	x	x					70, 72	Failed refrigerating unit		
x							54	Room temperature too low		

**77. Customer notes:**

Dometic model No. ....  Gas       Electric       Gas/electric  
Dometic cooling unit type ..... Serial No. ....  
When purchased .....  
Where purchased (company's name & address) .....  
Where installed: .....  
Trailer make ..... Model ..... Size .....  
Summer home  .....  
Other  .....

Manual provided courtesy  
Bryant RV Services  
[www.byantrv.com](http://www.byantrv.com)

All manuals are believed to be released for distribution, and/or in the public domain.

Service manuals provided with the understanding that persons using them are well versed in proper safety practices, and are familiar with basic safety procedures, including, but not limited to safety procedures dealing with 120 volt electricity, high amperage 12 volt circuits an LPG (propane) systems.

If in doubt, consult a professional (better safe than sorry).