



# Service Manual & Parts List for Model 1200LR

## Contents

Safety Information . . . . .	1	Procedure for Cleaning Cooling System Flue . . .	19
Introduction . . . . .	2	Cooling System Replacement . . . . .	20
Specifications . . . . .	3	Ice Maker Trouble Shooting Procedures . . . . .	22
Operating Controls . . . . .	5	Ice Maker Wiring Harness Removal . . . . .	26
Operating Sequence . . . . .	5	Component Check Out Procedures . . . . .	27
Diagnostics Fault Indicators . . . . .	7	Fuse Replacement Procedure . . . . .	29
Step-by Step Trouble Shooting . . . . .	9	Retractable Door Seal Removal . . . . .	30
Internal Control Information . . . . .	12	Door Handle Removal . . . . .	30
Diagnosing Cooling Problems . . . . .	17	Wiring Pictorials/Schematics . . . . .	31

Read this manual carefully and become thoroughly acquainted with its contents before servicing this refrigerator

**NOTICE: THIS APPLIANCE IS NOT APPROVED FOR USE AS A FREE-STANDING REFRIGERATOR OR FOR MARINE APPLICATIONS. THIS APPLIANCE IS EQUIPPED FOR LP GAS AND CANNOT BE CONVERTED TO ANY OTHER FUELS (NATURAL GAS, BUTANE, ETC.).**

Be alert to a potential Safety Hazard when the Safety Alert Symbol  appears on your refrigerator or in this manual. Also, be alert to the shaded areas in this manual; they contain important safety and performance information.

A signal word (i.e., Danger, Warning, Caution) accompanying the Safety Alert Symbol identifies the severity of the Safety Hazard. Review the safety symbols and signal words below. Carefully read their descriptions to understand their meaning. They are for your safety.

 DANGER indicates the presence of a hazard that will cause severe personal injury, death, or substantial property damage if ignored

 WARNING indicates the presence of a hazard that can cause severe personal injury, death, or substantial property damage if ignored.

 CAUTION indicates the presence of a hazard that will or can cause a minor personal injury or substantial property damage if ignored.

***Always apply the following safety precautions when servicing this refrigerator. Failure to follow these precautions can result in substantial property damage, severe personal injury, or death.***

- Improper installation, adjustment, alteration, unauthorized or improper servicing and maintenance of this refrigerator can cause severe personal injury, property damage, or both.
- This refrigerator **must** be used in the manner for which it was designed. Refer to the "Operator's Guide" and "Installation Requirements" manuals for refrigerator's intended use and installation.
- Keep refrigerator and surrounding area clean. Never store combustible materials at rear of refrigerator. Storing combustible materials at rear of refrigerator not only creates a safety hazard, but also inhibits air flow to the cooling system, reducing cooling efficiency.
- Keep liquids away from electrical connections. Many liquids are electrically conductive and can cause arcing or fires.
- Propane gas can cause an explosion that may result in property damage, personal injury, or death. Use extreme care when working with or near a propane gas system. Do not smoke or create sparks. Do not use an open flame to check supply piping and fittings for leaks.
- To prevent gas leaks and damage to gas supply lines and fittings, use two wrenches when connecting or disconnecting gas fittings.
- The 120 volt AC circuit must be properly grounded. Never cut or remove round grounding prong from refrigerator's AC power cord. Do not use a two-prong adapter. Do not use an extension cord.
- To prevent short circuits, connect positive DC supply lead to refrigerator before attaching ground lead.
- Always replace a blown fuse with a fuse of same ampere rating. A circuit overload can result in an electrical fire if undersized wires or improperly sized fuses are used. To prevent a possible electrical fire, follow Norcold's wire and fuse size specifications and any applicable state, local, or national codes.
- Always disconnect both AC and DC power sources from refrigerator when performing routine maintenance.
- Keep liquids away from electrical connections. Many liquids are electrically conductive and can cause serious arcing damage and fires.
- Cooling unit contents under pressure. Leaking cooling unit contents can cause severe burns to eyes and skin, and can ignite and burn with an intense flame. The cooling unit contains sodium chromate. Inhalation of certain chromium compounds can cause cancer. Do not attempt to repair or to recharge a defective cooling unit. Do not bend, drop, drill, weld, manipulate, or hammer the cooling unit.

- This refrigerator has sharp edges and corners at the rear. Use care when working on this refrigerator. To prevent cuts or abrasions, wear cut resistant gloves.
- Surfaces at rear of refrigerator are extremely hot. Contact with these surfaces can result in minor burns. Turn refrigerator off for several hours before attempting to move or service refrigerator.
- To prevent child entrapment, limit access to the refrigerator and insure all wire shelf retainers are securely fastened. Always remove the doors before disposing of any refrigerator.

## **Introduction**

To thoroughly understand the 1200LR refrigerator, review "Installation Requirements" and "Operator's Guide".

### **Purpose**

This manual provides service information for Norcold's 1200 LR refrigerators. This is a service guide for the experienced repair technician, and covers diagnostic procedures, trouble shooting, and repair procedures. It is recommended that repair technicians be knowledgeable with the function of an absorption refrigerator and have a basic understanding of propane and electrical systems.

Read all service procedures, cautions, and warnings before servicing refrigerator. It is critical that the refrigerator installation is in accordance with Norcold's recommended procedures, which are in compliance with standards for RV installations (see "Installation Requirements" manual). The areas which are crucial to the user's safety and refrigerator performance include removal of the products of combustion, isolation of living space of vehicle from the combustion system of refrigerator, removal of excess heat from the generator area of refrigerator's cooling system, and removal of heat that is extracted from the refrigerator cabinet (review the "Installation Requirements" manual).

### **Parts**

Always use genuine Norcold replacement parts when servicing the refrigerator. Generic replacement parts may look similar but do not meet Norcold quality and performance specifications. Only genuine Norcold replacement parts have been proven to provide reliable, safe operation and performance. Order genuine replacement parts through your local Norcold parts distributor.

### **Technical Support**

This manual is intended to provide the repair technician with all necessary information for successful service of the refrigerator. If after referring to this manual the problem has not been resolved, technical service is available at 1-800-543-1219.

## Specifications

MODEL		1200LR						
Storage Volume Freezer Compartment Fresh Food Compartment	cu. ft.	Two Freezer Compartments at 3.6 cu. ft. each 8.0 cu. ft.						
Cut-Out Dimensions W x H x D	in.	32 11/16" x 63 1/4" x 24"						
Certified Vent Kit Combination of any lower intake vent with the upper exhaust vent make Vent Kit #3		Vent Kit #3 Cut - Out Dimensions - inches(cm)						
				Exhaust Vent		Lower Intake Vent		
		Part No.	Type	Length	Width	Height	Width	Radius
		617778	Plastic	--	--	13 3/4 (34.93)	21 1/2 (54.61)	--
		616010	Square Corner	--	--	13 3/4 (34.93)	21 3/4 (55.25)	--
		616009	Radius Corner	--	--	13 3/4 (34.93)	21 7/8 (55.56)	3 1/4 (8.26)
		615791(cap) 616319B (Base)	Exhaust Vent	24 (60.96)	5 1/4 (13.34)	--	--	--
Venting & Installation		Certified Installation Requires; Vent Kit No. 3 installed without modification, Unobstructed air flow across the refrigerator's cooling system, Clearances between the refrigerator and any adjacent surface Two ventilation fans mounted at rear of refrigerator. Top        0"- 1/4" Sides      0"- 1/2" Rear        0"- 1" Bottom     0"						
Door Panel Dimensions (Inches) Freezer Doors H x W Fresh Food Compartment Doors H x W Thickness = 3/16"		17 17/32" x 16 13/64" 40 11/32" x 16 13/64"						

<b>Supply Voltage Requirements</b>	
DC	15.4 VDC Max. - 10.5 VDC Min.
AC	132 VAC Max. - 108 VAC Min.
<b>Operating Requirements</b>	
LP Gas Operation	<p><b>12 volt DC is required to operate and maintain the operating controls.</b>            12 volts needed to operate the interior light, moisture reduction heater, and the gas ignition circuit. LP (Propane) Gas supply pressure at 11" Water Column.</p>
	0.19 Jeweled Orifice
AC Operation	<p><b>12 volt DC is required to operate and maintain the operating controls</b>            120 volt, 60 Hertz grounded AC circuit is needed to operate the AC heaters.            12 volts needed to operate the interior light and the moisture reduction heater.</p>
<b>Fuses</b>	
Refrigerator Internal Fuse	<p style="text-align: center;">DC Control Voltage            3 Amp Blade Type</p> <p style="text-align: center;">AC Circuit            8 Amp Glass Type</p>
<b>DC Supply Wire Requirements</b>	
*0-20' & over 20'	
Min. Wire Size	18 AWG
Min. Fuse Size (In-line)	6 Amp
<b>Heater Specifications</b>	
Two 225 Watt AC Heaters	
Watts/Amps/Ohms	450 Watts 4.2 Amps 48.9 Ohms
Ohms reading +/- 5%	

<b>Current Draws</b>	
Automatic Ignition	.50 amps
Moisture Reduction (Divider/Door Seal) Heaters	.70 total amps
Interior Light	.60 amps
AC Heating Elements	4.2 amps
Two Ventilation Fans	.30 amps each fan or .60 amps total

## Operating Controls

A 12 volt DC supply is required to maintain refrigerator's operating control functions. The refrigerator receives its DC power from the vehicle's 12 volt system; either an auxiliary battery, a converter, or the engine battery. The 12 VDC system not only supplies power to the refrigerator, but to other DC components in the vehicle.

The operating controls consist of two printed circuit board assemblies. The Control Board, located at the rear of the refrigerator, contains the circuitry to operate the refrigerator. The Front Display Panel, located between the freezer and fresh food compartments, contains the push-button switches, displays the temperature settings, operational modes, and fault codes.

### Front Display Panel



Figure 1

### Operating Instructions

The ON/OFF button (A) turns the refrigerator on or off. When the refrigerator is off, pressing this button will turn the refrigerator on and set the mode to AUTO. When the refrigerator is on, pressing this button and holding for **2 seconds** will turn the refrigerator off.

Pressing and holding the MODE button (C) allows the user to cycle through the three mode choices; on AUTO (F) and two manual modes; AC (G) and LP GAS (H). The refrigerator will not switch to the new operating mode until the MODE button is released.

The TEMP SET (thermostat) button (B) controls the refrigerator and freezer temperature during both gas and electric operation. Press and hold the TEMP SET button to select the desired temperature setting. The temperature settings are shown in the form of LED's (E). The illuminated LED indicates the temperature setting, with COLD on the left and COLDEST on the right. The temperature LED turns off after 10 seconds. Quickly press and release any button to display temperature setting.

## Operating Sequence









### Auto Mode







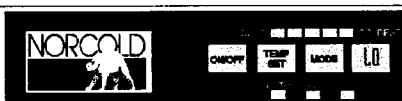



When AUTO mode is selected, the operating control automatically selects the energy source using the following priority scheme:

- When 120 volt AC is available to the refrigerator, the AUTO LED and the AC LED will illuminate, indicating the refrigerator is operating on AC electric. After 10 seconds, the AC LED will turn off and only the AUTO LED will remain illuminated. Press and quickly release any button to display the operating mode.
- If 120 volts AC is not available, the refrigerator will switch to gas operation. The AUTO LED and the LP GAS LED will illuminate. After 10 seconds, the LP GAS LED will turn off and only the AUTO LED will remain illuminated. Press and quickly release any button to display the operating mode.

## Fault Indicators

The refrigerator's operating control is equipped with on-board diagnostics which assist the service technician in trouble shooting and alert the refrigerator owner to a problem in any mode of operation. When a problem occurs within a given mode, the operating controls will revert to a stand-by mode in which an alarm will sound, and alpha code will be displayed in the diagnostic screen. The alarm will sound until an alternate operating mode is selected. The alpha code will continue to be displayed until the controls are turned off and then back on or until the problem is corrected. Codes and their meanings begin below.

When:	IT MEANS	CORRECTIVE ACTIONS
 <p>Flashing "no", Flashing "LP LED" &amp; alarm</p>	<p>LP Gas Ignition Fault or LP Gas Re-Ignition Fault</p>	<p>See Section 2 on page 10</p>
 <p>Flashing "dr" &amp; alarm</p>	<p>Door Left Open For More Than 2 Minutes</p>	<p>See Section 3 on page 10</p>
 <p>Flashing "no", Flashing AC LED &amp; Alarm</p>	<p>AC Mode Selected; AC Power Not Available</p>	<p>See Section 4 on page 10</p>
 <p>Flashing "LO", Flashing AC LED &amp; Alarm</p>	<p>AC Input Voltage too Low</p>	<p>See Section 5 on page 10</p>
 <p>Flashing "HI", Flashing AC LED &amp; Alarm</p>	<p>AC Input Voltage too High</p>	<p>See Section 6 on page 10</p>
 <p>Flashing Current Temperature Setting LED</p>	<p>"Back-Up Operating System" Mode Fault Within Refrigerator Controls</p>	<p>See Section 7 on page 10</p>
 <p>Flashing "LO" &amp; Alarm</p> <p>then</p>  <p>Flashing "dc" &amp; Alarm</p>	<p>DC Control Voltage too Low</p>	<p>See Section 8 on page 10</p>

 <p>Flashing "HI" &amp; Alarm</p> <p><b>then</b></p>  <p>Flashing "dc" &amp; Alarm</p>	<p>DC Control Voltage too High</p>	<p>See Section 9 on page 11</p>
 <p>Flashing "Sr", Flashing AC LED &amp; Alarm</p> <p><b>then</b></p>  <p>Flashing "CL" &amp; Alarm</p>	<p>AC Relay Stuck In Closed Position</p>	<p>See Section 10 on page 11</p>
 <p>Flashing "Sr", Flashing AC LED &amp; Alarm</p> <p><b>then</b></p>  <p>Flashing "OP", Flashing AC LED &amp; Alarm</p>	<p>AC Heater Failed Open (Voltage But No Current)</p>	<p>See Section 11 on page 11</p>
 <p>Flashing "Sr", Flashing LP LED &amp; Alarm</p> <p><b>then</b></p>  <p>Flashing "fs", Flashing LP LED &amp; Alarm</p>	<p>Flame Sense Circuit Failure</p>	<p>See Section 12 on page 12</p>
 <p>Flashing "Sr", Flashing AC LED &amp; Alarm</p> <p><b>then</b></p>  <p>Flashing "CU", Flashing AC LED &amp; Alarm</p>	<p>AC Heater ON Current; Out of Tolerance</p>	<p>See Section 13 on page 12</p>



## Step-by-Step Trouble Shooting by Fault Indicators

This section is intended to serve as a check list to aid the repair technician in solving a problem. Look at the fault indicator (Diagnostic Fault Indicators and Corrective Actions on page 13) and its meaning, then follow the guide to correct the problem.

### Section 1 - No Display on Display Panel

#### Corrective Action

1. Battery charging equipment or converter.
2. Input DC supply voltage to the refrigerator's control board. Correct if DC Voltage is below 10.5 VDC.
3. 12 VDC supply wire connections to the control board. Correct if loose.
4. Remove the control board cover and check the 3 Amp control voltage fuse. Replace if defective.
5. If the 3 amp fuse blows after replacement, insure the interior light cover is installed correctly. If the 3 amp fuse continues to blow, disconnect the light wires from the light bracket. Start refrigerator. If fuse does not blow, replace light bracket. If fuse blows, replace control board.

**⚠ Caution: A circuit overload can result in an electrical fire when incorrect size fuses are used. To prevent a possible electrical fire, replace a blown fuse with the exact replacement. Refer to "Specifications" chart on page 4 for correct fuse size and type.**

6. Check wire harness connection to control board. Secure connection if needed.
7. At front of refrigerator, remove front display panel to gain access to wire harness connection.
8. Inspect pins of the wire harness. Insure they are seated within the connector.
9. Check for 12 VDC between points A and B (Figure 4).
10. If 12 VDC is present, replace front display panel. If 12 VDC is not present, replace power board.

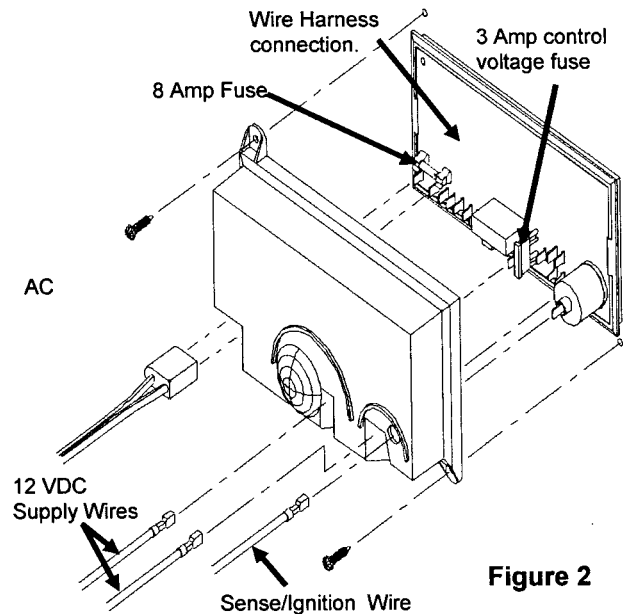

Figure 2

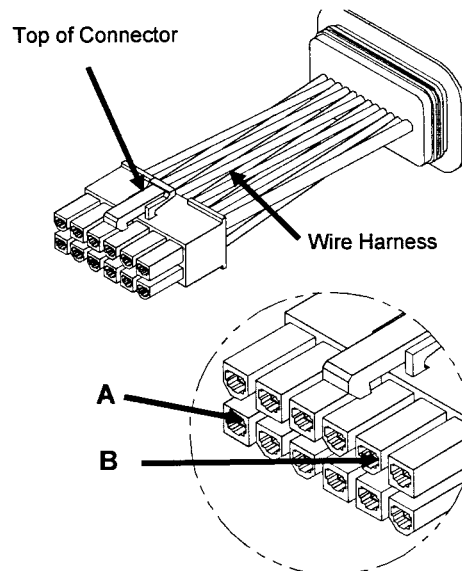

Figure 3

### **Section 5 - AC Input Voltage too Low (See Internal Control Information)**

#### **Corrective Actions**

Check input AC supply voltage to refrigerator. Correct input AC voltage (108 VAC 132 VAC max.).

### **Section 6 - AC Input Voltage too High (See Internal Control Information)**

#### **Corrective Actions**

Check input AC supply voltage to refrigerator. Correct input AC voltage (108 VAC 132 VAC max.).

### **Section 7 - Back-Up Operating System**

If the thermistor becomes inoperable, the power board will revert to the Back-Up Operating System. When the refrigerator enters this mode the thermistor is ignored and the refrigerator interprets the thermostat setting as a duty command.

#### **Corrective Action**

Replace Lamp/Thermistor Wire Assembly

### **Screen 8 - DC Input Voltage too Low (See Internal Control Information)**

#### **Corrective Actions**

1. Check input DC supply voltage to refrigerator. Correct input DC voltage(10.5 VDC min.)
2. Check DC supply wire connections at power board. Secure connections if loose.
3. Check vehicle's battery charging equipment. Correct charging equipment.

### **Section 9 - DC Input Voltage too High (See Internal Control Information)**

#### **Corrective Actions**

1. Check input DC supply voltage to refrigerator. Maximum input DC voltage is 15.4 VDC.
2. Check vehicle's battery charging equipment. Correct equipment.

### **Section 10 - AC Relay Stuck In Closed Position**

#### **Corrective Action**

1. Replace power board.

### **Section 11 - AC Heater Failed Open**

AC voltage being supplied to AC heater but the heater is not drawing current.

#### **Corrective Action**

1. Measure the resistance through the AC heater. An open heater reads infinity and requires replacement.
2. If AC heater is not found open, replace power board.

## Section 12 - Flame Sense Circuit Failure

### Corrective Action

1. Check for cracks or breaks in the sense/ignition wire. Replace when cracks or breaks are found.
2. Check alignment of electrode. Adjust to 1/8" to 3/16 " from top of burner.
2. Check the sense/electrode wire for continuity. Replace if no continuity found.
3. Check the sense/ignition wire for short to ground. Any reading, replace sense/ignition wire.
4. Check ignition wire connection at power board. Secure connection if loose.
5. Replace power board.

## Section 13 - AC Heater Failed for Current Out of Tolerance

### Corrective Action.

Check AC heaters for correct wattage (225 Watt each) and measure resistance of the heater. The heaters are to measure between 38.3 and 42.3 Ohms. Replace if resistance is not within specifications.

## Internal Control Information

Internal control information provides additional information to aid in trouble shooting. To access the Internal Control Information mode, press and hold both the TEMP SET and the MODE buttons simultaneously for five (5) seconds. While in the Internal Control Information mode, the refrigerator continues to operate in the mode selected prior to entering the information mode. Different information displays can be selected by pressing the MODE button. To exit this mode, press both the TEMP SET and the MODE buttons simultaneously for two (2) seconds, after which the control reverts to the normal operating display.

### Screen No. 1



Figure 4

All LED's and the numerical segments of the diagnostic display window are illuminated verifying that the control board LED's and numerical segments are functional.

## Screen No. 2

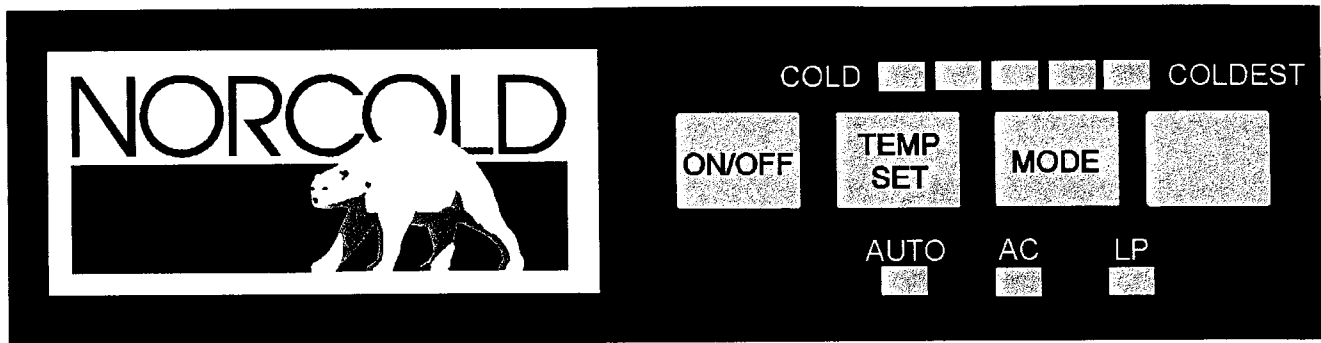

Figure 5

This screen indicates that LED's and the diagnostic screen numerical segments are not stuck in the ON position.

## Screen No. 3 - Inputs and Outputs

This screen, the refrigerator control illuminates the temperature LED's which indicate control real time activity.

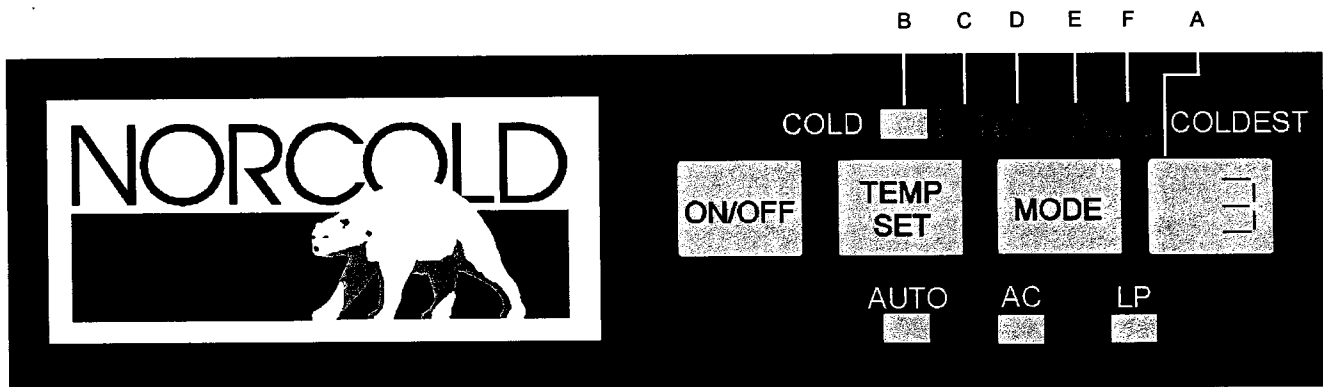

Figure 6

A - Identifies information screen.

B - Not Applicable

C - **Gas Operation** - LED on signifies flame present at burner.

D - **AC Electric mode** - LED on signifies that AC voltage is present to AC heaters and within specifications (108 VAC min. - 132 VAC max.).

E - **ALL modes of operation** - LED on signifies the power board is supplying DC voltage to power the moisture reduction (divider) heater.

F - **LP GAS mode** - LED on signifies the power board is supplying power to the gas valve.

## Screen No. 4 - Inputs and Outputs

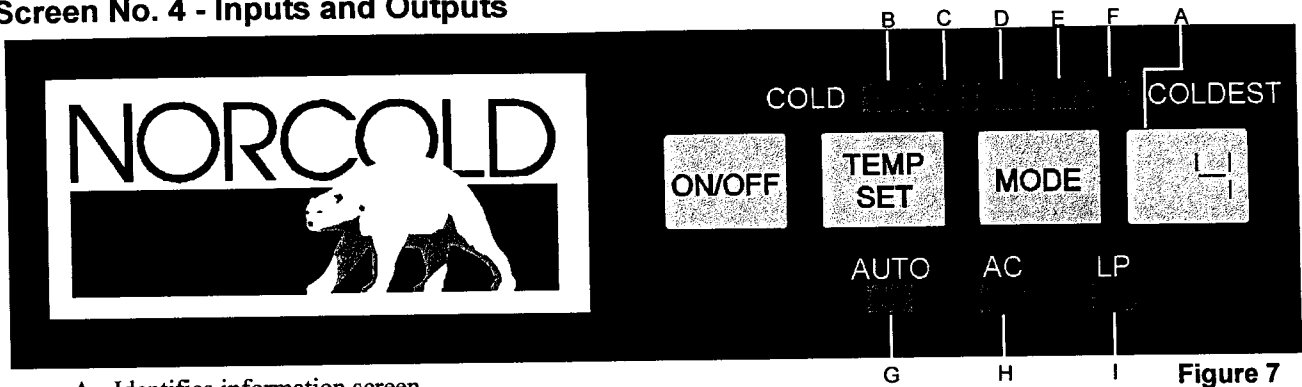

A - Identifies information screen.

B - All Operating Modes - LED on signifies the power board is supplying DC voltage to the flapper moisture reduction heater.

C - All Operating Modes - LED on signifies the power board is supplying voltage to energize the selected operating mode.

D - AC Electric Mode - LED on signifies that AC is available to the AC heaters and within AC input voltage specifications.

E - All Operating Modes - LED on signifies that the door switch is in the closed (normal) position; that the fresh food compartment door is closed, and the interior light is off.

F - All Operating Modes - LED on signifies the power board is supplying DC voltage to activate the interior light.

G - AUTO MODE - LED on signifies the current operating mode is AUTO.

H - AC Electric - LED on signifies the current operating mode is AC.

I - LP GAS - LED signifies the current operating mode is LP Gas.

## Screen No. 5 - Operating Controls Fault History

This screen displays the fault history of the refrigerator's operating controls. When entering this screen, an illuminated LED indicates the operating controls previous failure. It is possible that the LED's will not be illuminated. When an LED is illuminated, use the "Step-by-Step Trouble Shooting by Fault Indicators" beginning on page 9.

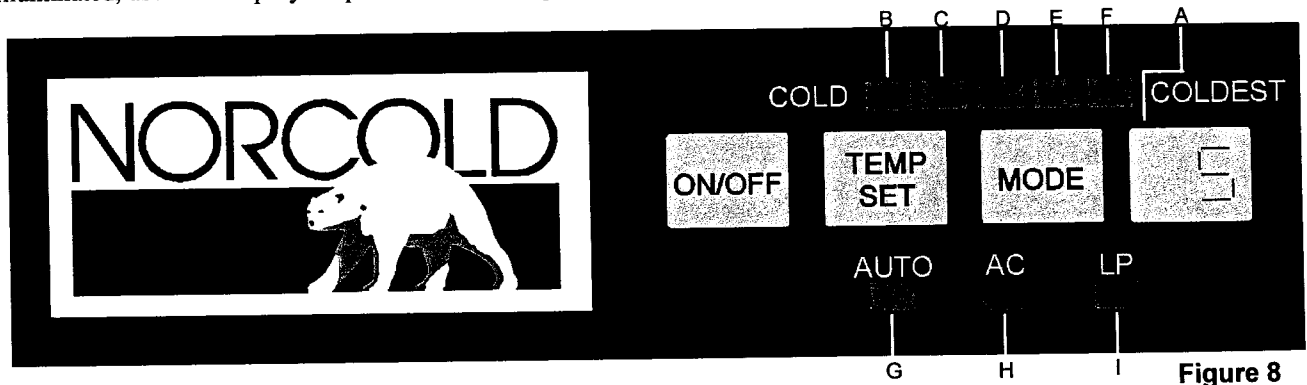

A - Identifies information screen.

B - LED on signifies a problem occurred with the AC heating elements.

C - LED on signifies that AC power to the AC heating elements was out of tolerance.

D - LED on signifies that AC input voltage was low.

E - LED on signifies that AC input voltage was high.

F - LED on signifies the power board's AC relay was stuck in the "ON" position.

G - LED on signifies that ignition failure occurred.

H - LED on signifies that a flame sense failure occurred.

I - LED signifies that a failure occurred in the thermistor or temperature sensing circuit.

## Screen No.6 - Operating Controls Fault History

This screen displays the fault history of the refrigerator's operating controls. When entering this screen, an illuminated LED indicates the operating controls previous failure. It is possible that the LED's will not be illuminated. When an LED is illuminated, use the "Step-by-Step Trouble Shooting by Fault Indicators" beginning on page 9.



Figure 9

A - Identifies information screen.

B - LED on signifies that the refrigerator door has been left open for more than 2 minutes.

C - LED on signifies that AC input voltage was not available to the refrigerator.

D - Inner control failure. Fault within power board. Power board requires replacement.

E - LED on signifies the DC input voltage was low.

F - Led on signifies the DC input voltage was high.

## Screen No. 7 - Fin Temperature Sensed by Thermistor

The temperature will be displayed in degrees Fahrenheit on the diagnostic display window.



Figure 10

A - Cooling fin temperature

The following procedure verifies the thermistor is functioning

1. Remove the thermistor from the fin and immerse thermistor end in ice water. The temperature displayed should be between 29° F and 35° F.
2. Remove the thermistor from the ice water and hold thermistor end in hand. The temperature displayed should rise.
3. If the temperature does not fall and rise when performing steps 1 and 2 above, replace thermistor assembly.

Shown 38 = 38°F

## Screen No. 8 - AC Input Voltage

This screen displays AC input voltage measured by the control.

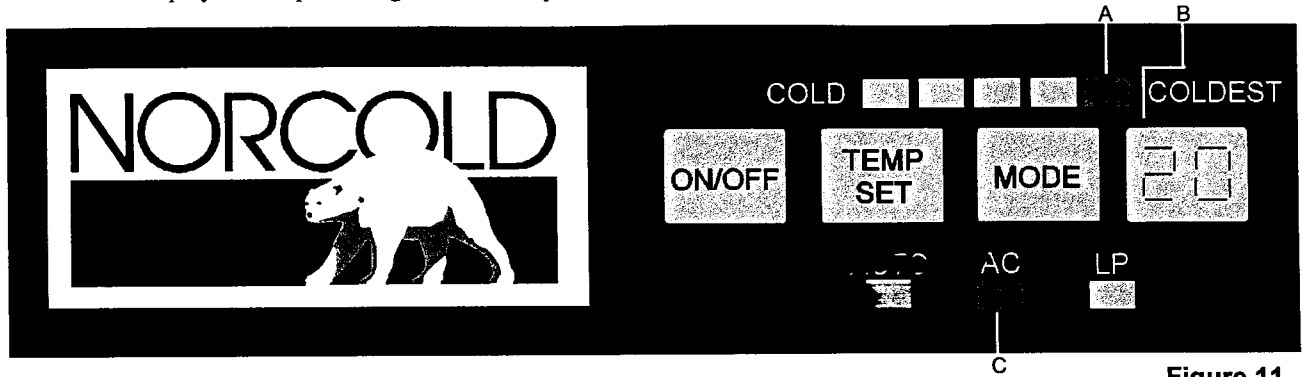

Figure 11

A - Illuminated LED signifies AC voltage greater than or equal to 100 volts AC.

B - The control displays the measured AC voltage over 100 volts.

C - Indicates AC electric measurement:

**Shown:  $100 + 20 = 120$  VAC**

To verify:

Measure the AC input voltage at the receptacle supplying AC voltage to the refrigerator. The voltage should be +/- 10 % VAC of the controls display.

Measure the output voltage of the power board to the AC heaters. The voltage should equal the input voltage.

## Screen No. 9 - AC Heater Current

The screen displays AC heater current measured by the control.

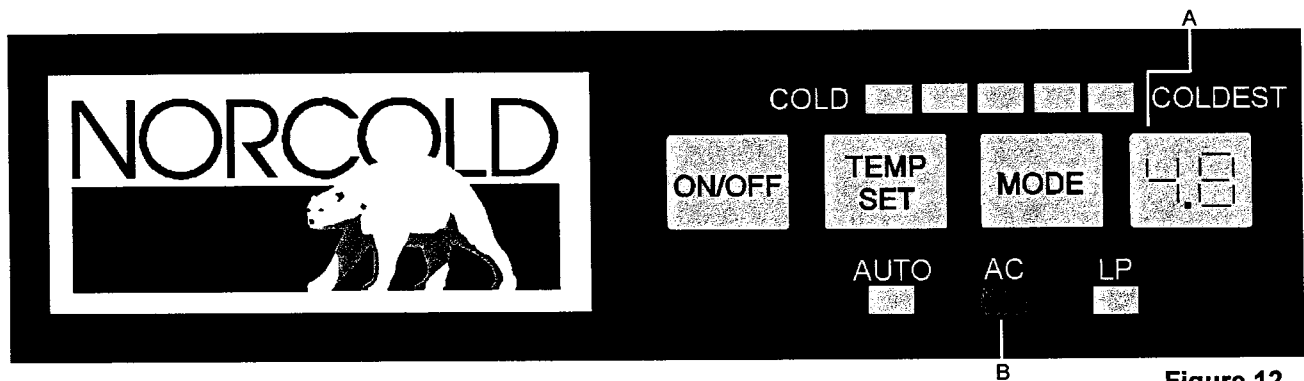

Figure 12

A - The control displays the AC heater (2) current measured by the control.

B - Indicates AC electric measurement:

**Shown 4.8 amps**

To verify:

Measure the AC current through the two AC heaters (2.0 -2.4 Amps each heating element). The current measured should be +/- 5% of the control's display.

## Screen No. 10 - DC Input Voltage

This screen displays the measured DC input voltage by the control.



Figure 13

A - The control displays the measured DC voltage over 10 volts.

B - Illuminated LED signifies DC voltage greater than or equal to 10 volts DC.

**Shown:  $10 + 2.0 = 12$  VDC**

To verify:

To verify:

Measure the input DC voltage to the power board. The will be +/- 1.0 VDC of the control display.

## Diagnosing Cooling Problems

**Note: If the refrigerator operates on one heat source but not another, the problem is not the cooling system. Before continuing with this procedure, refer to the diagnostic section. Diagnose the cooling system only when the refrigerator does not cool or cools marginally on both the AC electric and LP Gas modes.**

### Make Certain the refrigerator owner understands:

- Unlike a home refrigerator, an RV refrigerator requires the foods to be pre-cooled; frozen foods should be pre-frozen before loading the refrigerator. Loading a warm refrigerator with warm food increases the cool down time. Turn the refrigerator on for several hours before loading.
- Annually clean the burner, burner orifice, and if necessary clean the flue of the cooling system. These areas are to free of foreign materials to allow the refrigerator to perform (cool) properly.
- For best cooling performance, air must be free to circulate within the fresh food compartment. Do not cover the shelves with paper, plastic, etc.
- Reduce frost formation, cover liquids and moist foods. Do not place hot foods in the refrigerator, and do not leave the door open longer than necessary.
- Periodically inspect the ventilation system. Remove obstructions such as bird and squirrel nests, etc.
- Do not use the intake vent area for storage. Storing items will block the air flow needed for cooling performance.
- Place ice cube trays flat on bottom surface of the freezer to make ice.



## Off Level Condition



### WARNING

Operating refrigerator outside of the cooling system specification of 3 degrees off level side-to-side and 6 degrees off level front-to-back can cause irreparable damage to cooling system and can create a risk for personal injury or property damage. Level vehicle before operating refrigerator.

Insure that refrigerator is operating within cooling systems specifications of 3 degrees off level side-to-side and 6 degrees off level front-to-back. The vehicle may be level but refrigerator may not be because of improper installation.

## Installation/Ventilation

Extremely hot days ( 90 ° or higher) can lead to warmer temperatures in both the freezer and fresh food compartments, especially when air flow across cooling system is restricted. Make sure refrigerator is installed in accordance with Norcold's installation requirements. Refer to "Installation Requirements" manual (provided with each refrigerator).

## Inputs

Make certain that:

- The AC and DC voltages and the LP Gas supply pressure are within the required specifications. Refer to "Specification" charts on pages 3 and 4.

## Refrigerant Charge Solution



### WARNING

Corrosive liquid. Eye or skin contact can cause severe burns. Contents under pressure. Leaking gas can ignite and burn with intense flame. Leaking coolant solution can cause severe burns to the eyes or skin, and can ignite and burn with intense flame. Sodium chromate contains chromium. Certain chromium compounds can cause cancer by inhalation. Do not cut, weld, hammer, drill or bend unit. Do not drain or recharge. Avoid skin and eye contact with liquid contents. Keep away from ignition source if contents are leaking. **FIRST AID: Skin or eye contact:** Immediately flush eyes or skin with water for a minimum of 15 minutes.

## Refrigerant Leaks

The cooling unit must be replaced if:

- A yellow powder is visible at rear of the refrigerator.
- An ammonia odor is detected inside the refrigerator cabinet or at the rear of the refrigerator.

## Blocked Cooling System

- Allow the refrigerator to operate for a maximum of 1 hour.
- Check the absorber coils on the cooling system. If the absorber coils "A" are cold and the flue area "B" is hot to the touch, the cooling unit is blocked and requires replacement.

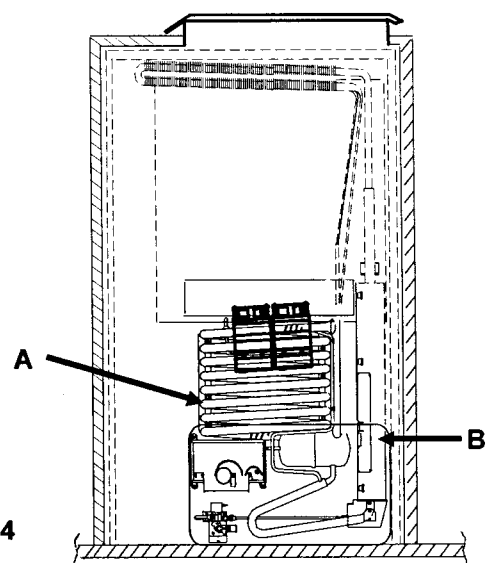

Figure 14

## Procedure for Cleaning the Cooling System Flue

**! WARNING Hazardous gas! Carbon Monoxide can cause nausea, fainting, or death. Inadequate ventilation or partial blockage of the refrigerator's flue can result in increased carbon monoxide emissions when operating in the gas mode. To prevent hazardous levels of Carbon Monoxide, installation must assure complete isolation of the living space of the R.V., and the burner, burner orifice, and the cooling system's flue tube must be cleaned at least once a year and after *all* prolonged (seasonal) shut-down periods. Follow Norcold's Ventilation and Installation recommendations explicitly and refer to the following cleaning procedures.**

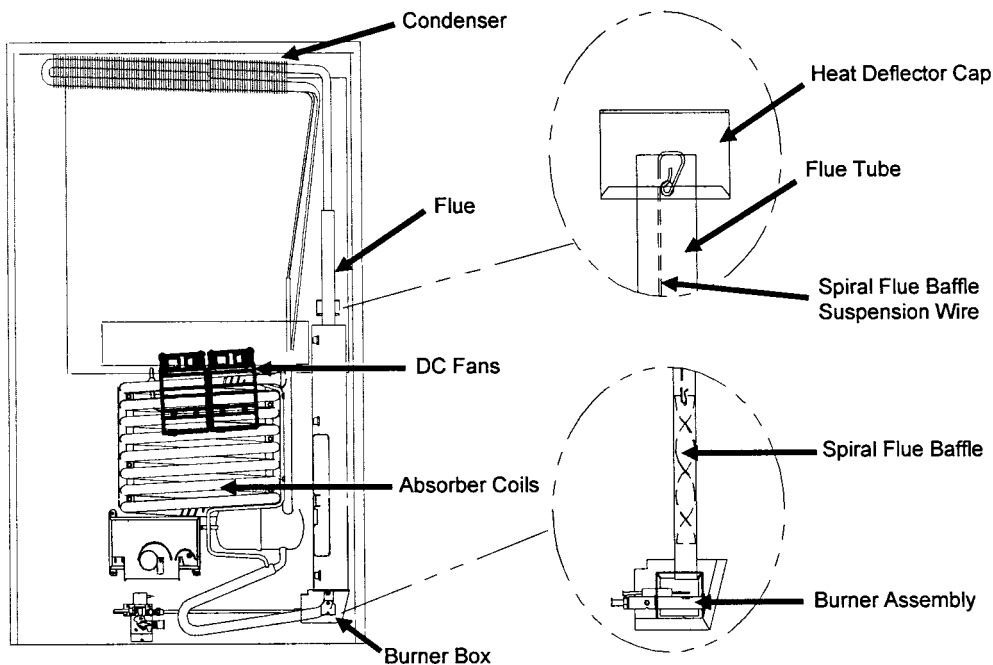
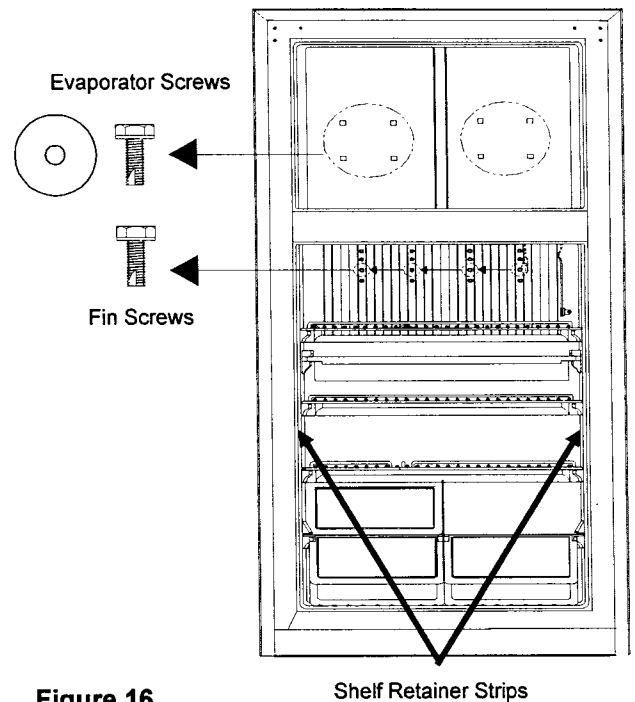

Figure 15

1. Turn off LP Gas at main tank.
2. Disconnect 12 volt DC supply wires to refrigerator.
3. Disconnect AC power cord from electrical outlet.
4. Using two wrenches, disconnect LP Gas supply line from refrigerator's gas valve.
5. Disconnect AC power cord from power board.
6. Remove mounting screws at rear of refrigerator.
7. Remove 6 mounting screws from front of refrigerator.
8. Slide refrigerator forward and remove from enclosure.
9. Remove heat deflector cap from flue, remove spiral baffle from flue tube.
10. Using a wire brush or fine emery cloth, clean the spiral flue baffle of debris.
11. Cover burner. Clean inside of flue tube with a flue brush.
12. Re-install spiral flue baffle. ***Insure spiral flue be securely in place. The spiral flue baffle is required for efficient cooling while operating in gas mode.***
13. Re-install refrigerator by reversing Steps 1-8.

## Cooling System Replacement Procedures

1. Turn off LP Gas at main tank.
2. Disconnect 12 volt DC supply wires to the refrigerator.
3. Disconnect AC power cord from electrical outlet.
4. Using two wrenches, disconnect LP Gas supply line from the refrigerator's gas valve.
5. Disconnect AC power cord from power board.
6. Remove mounting screws at rear of the refrigerator.
7. Ice Maker models only, disconnect water supply line to water valve of refrigerator.
5. Remove 8 screws from the freezer compartments.
6. Remove the 7 screws from the fins. Detach the thermistor from the fins.
7. Remove both shelf retainer strips.
8. Slide top shelf and drip tray forward. Remove red clamp from drip hose. Remove top shelf and drip tray.
9. Remove 6 mounting screws from front of the refrigerator.
10. Slide refrigerator forward and remove from enclosure.
11. Remove power board cover and disconnect AC heater wires.
12. Remove both DC fans and thermostat.
13. Disconnect burner tube at gas valve.
14. Remove drip cup and burner box cover.
15. Remove drip hose. Save for later installation.
16. Remove 4 screws securing cooling system to refrigerator cabinet (two at condenser and two at absorber).
17. Remove the cooling system from the cabinet. Carefully pull the system away from cabinet with steady pressure. Use care not to drop or bend the fins.
18. Remove all permagum sealant from the cabinet.



**Figure 16**

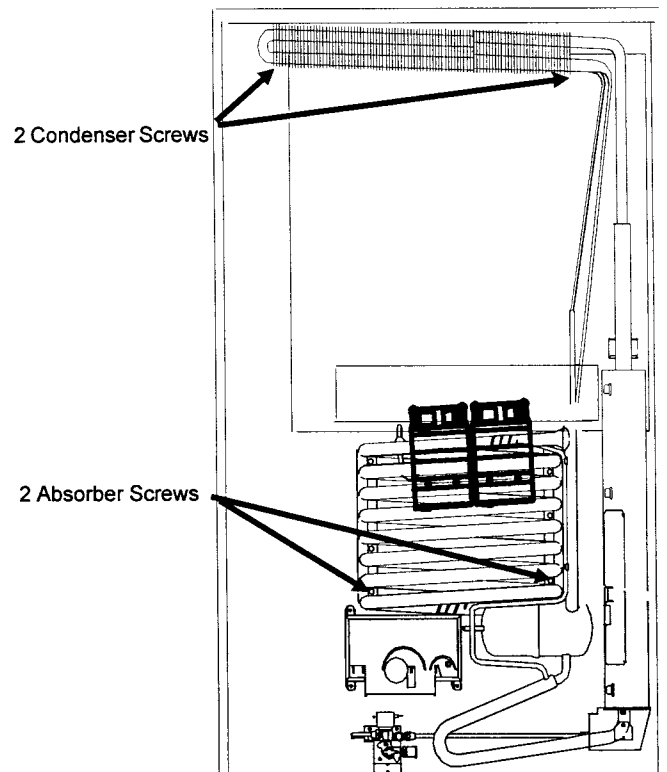

**Figure 17**

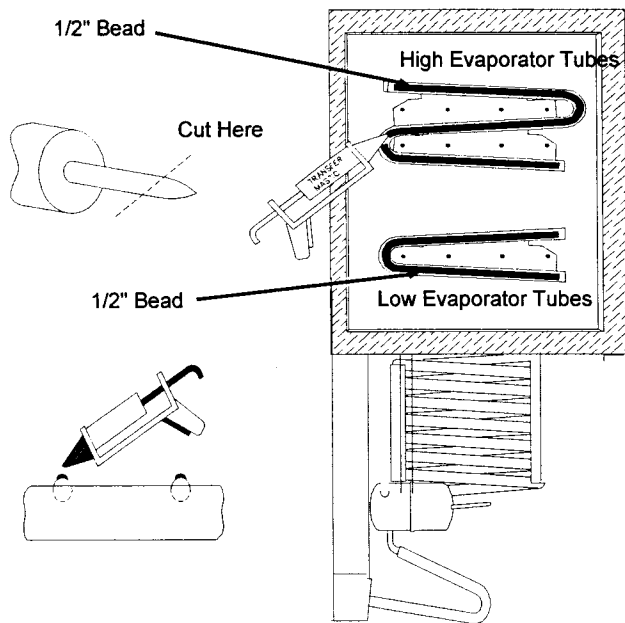

Figure 18

### Applying Permagum Sealant

Apply a 1/2" bead to sides, top, and bottom of the cooling system's foam block.

### Applying Transfer Mastic and Permagum Sealants

#### Important:

*The transfer mastic and permagum sealant **must** be applied to the cooling system before installation.*

In the carton with the cooling system are two tubes of materials. One tube contains a transfer mastic and one tube contains a permagum sealant.

To apply the transfer mastic and permagum sealant, cut the tip of both tubes to allow the materials to exit the tubes.

#### Applying Transfer Mastic

A 1/2" bead of transfer mastic is applied to the exposed portion of the high and low evaporator tubes of the cooling system.

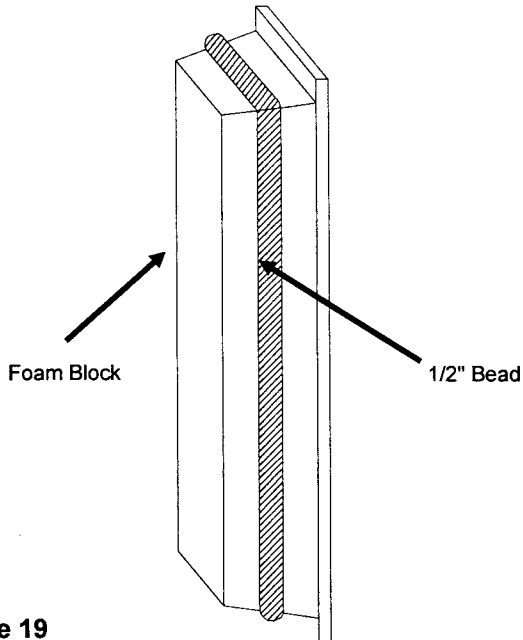

Figure 19

**To install cooling system, reverse the cooling system removal procedure.**

## Ice Maker Trouble Shooting Procedures

### Ice Maker Specifications

Volts: 120 volts AC  
 Amp Draw - cycle on, heater off: .03 amps  
 Amp Draw - cycle on, heater on: 1.6 amps  
 Amp Draw - cycle off: 0 amps  
 Inlet water pressure: 15 - 125 psi.  
 Duration of 1 cycle: 3.5 to 7 minutes  
 Ice Yield: 3 lbs./24 hours

### Ice Maker Requirements:

1. Cold potable water supply at pressures between 15 psi and 125 psi.
2. 120 Volts AC supply - 108 VAC minimum - 132 VAC maximum.
3. 1/4" O.D. cooper tubing (compression nut, compression sleeve, and 90° degree tubing adapter supplied with refrigerator) or an approved plastic tubing.
4. 1/4" Shut-off valve in water supply line. (Should be accessible when the lower vent door is open.)

### Problem/Probable Cause/Remedy

Problem	Probable Cause	Remedy
1. Refrigerator Cooling: No ice in bin	<ol style="list-style-type: none"> <li>1. A/C power disconnected.</li> <li>2. Broken wire or loose connection.</li> <li>3. Shut off arm in storage position.</li> <li>4. Water supply shut off.</li> <li>5. Inoperative water valve.</li> <li>6. Excessive frost build-up causing Shut- off arm to hang up.</li> </ol>	<ol style="list-style-type: none"> <li>1. Connect A/C power.</li> <li>2. Locate and repair.</li> <li>3. Place in normal operation position.</li> <li>4. Restore water supply.</li> <li>5. Check valve and inlet filter for restrictions or solenoid coil failure. Repair or replace.</li> <li>6. Defrost unit - inspect for door gasket leak.</li> </ol>
2. Low ice yield.	<ol style="list-style-type: none"> <li>1. Ventilation of refrigeration not in accordance with Norcold's Venting Requirements. See Section 2.</li> <li>2. Insufficient refrigeration.</li> <li>3. Not enough water supply pressure.</li> <li>4. Thermostat setting too warm.</li> </ol>	<ol style="list-style-type: none"> <li>1. Install in accordance with Section of this manual.</li> <li>2. Check 120 VAC power 108 VAC min. - 132 max. 12 VDC Power 10.5 VDC min. - 15.4 VDC max.</li> <li>3. A. Check for restrictions in water lines or water valve. B. Check for correct water pressure min. 15 PSI;</li> <li>4. Adjust Thermostat setting.</li> </ol>
3. Excessive water dripping on ice cubes or from Ice Maker mold.	<ol style="list-style-type: none"> <li>1. Excessive water pressure.</li> <li>2. Water valve sticking open.</li> </ol>	<ol style="list-style-type: none"> <li>1. Correct water pressure min. 15 PSI max. 125 PSI</li> <li>2. Check for contaminated inlet filter or replace water valve.</li> </ol>
4. Ice maker mold over-filling with water.	<ol style="list-style-type: none"> <li>1. Defective water valve.</li> </ol>	<ol style="list-style-type: none"> <li>1. Replace water valve.</li> </ol>
5. Ice cubes are milky or have taste.	<ol style="list-style-type: none"> <li>1. Water hardness or food stored in ice bin.</li> </ol>	<ol style="list-style-type: none"> <li>1. Advise customer to inspect water supply and not to store food in ice bin.</li> </ol>

## Ice Maker Trouble Shooting Procedures

These check-out procedures are based on the following:

- 12 Volts DC (Control Voltage) is available to the Refrigerator.
- 120 Volts AC is available to the refrigerator and to the Ice Maker.
- Water pressure to the ice maker is at 15 psi min. - 125 psi max.
- Thermostat is set at mid-range setting or higher.
- Refrigerator is performing satisfactory and has been operating long enough to reach ice making temperatures.
- The Ice Maker's shut-off arm in the down (on) position.

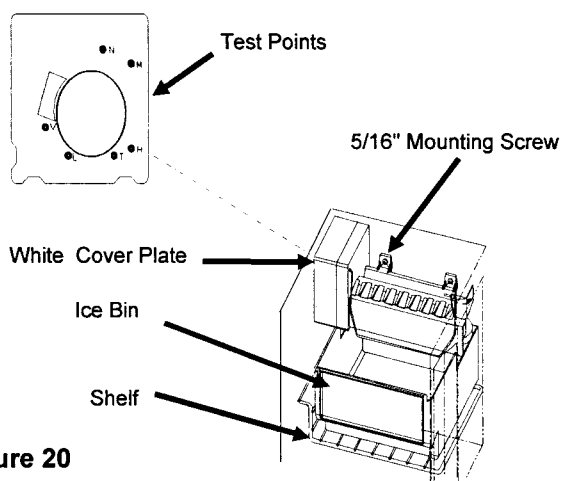

Figure 20

The wire harness is equipped with a thermal fuse. The fuse protects the ice maker mold from overheating. If the fuse is open, the wire harness requires replacement.

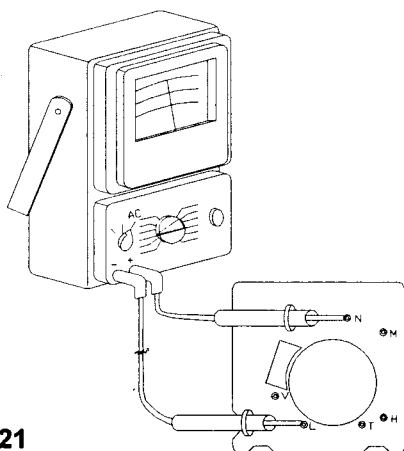

Figure 21

### Location of Test

Test points are located behind the white cover plate . To gain access to the test point, the ice maker is required to be removed from the freezer.

### Ice Maker Removal

1. Remove the ice bin and shelf.
2. Remove the two 5/16" mounting screws.
3. Using a Phillips screwdriver, remove the two screws under the ice maker.
4. Pull Ice Maker forward to remove.
5. Remove white cover plate.
6. Follow Check Out procedures.

### Wire Harness Check

Use a volt ohmmeter and check for 120 volts AC between test points L and N.

**Note: Insure your meter leads contact the surfaces of the test points.**

If 120 volts is present, proceed to "Water Valve" check out.

If 120 volts is not present, replace the ice maker's wiring harness. See Ice Maker Wire Harness Removal on page 28.

## Water Valve Check - Figure 7

Energizing the Water Valve

**Caution:** To prevent an electrical shock, use an insulated jumper wire.

**Note:** If water is available to the water valve, performing the procedure below may overflow the ice maker's mold.

Insert an insulated jumper wire between test points L & V to energize the water valve. If an audible click or buzzing is observed, the water valve is functional.

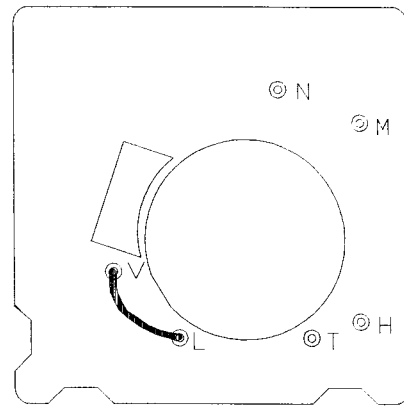

Figure 22

## Ohm Readings

If the water valve is not functional:

1. Disconnect the refrigerator's AC power cord from the wall receptacle.
2. Use a volt ohmmeter; insert meter leads into test points V & N.
3. Reading between 295 and 360 ohms indicate water valve is functional.
4. Reading is infinity (maximum reading) there is a loose wire connection at the water valve's terminals or the water valve is defective. Repair loose connection or replace water valve.
5. Reading of "0" indicates a short in the wiring from the ice maker to the water valve or a defective water valve. Repair the short or replace the water valve.

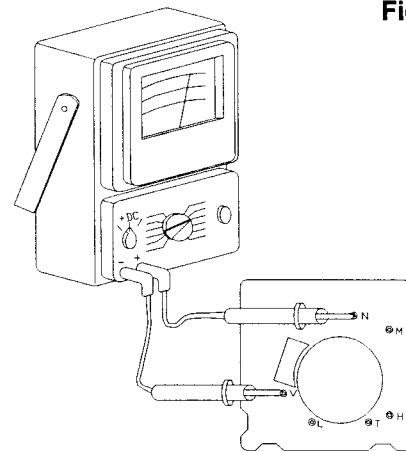

Figure 23

## Mold Heater

Use a volt ohmmeter and insert meter leads into test points L&H.

1. 75 ohm reading indicates the mold heater is functional.
2. Reading either an open or a short requires replacement of the ice maker assembly.

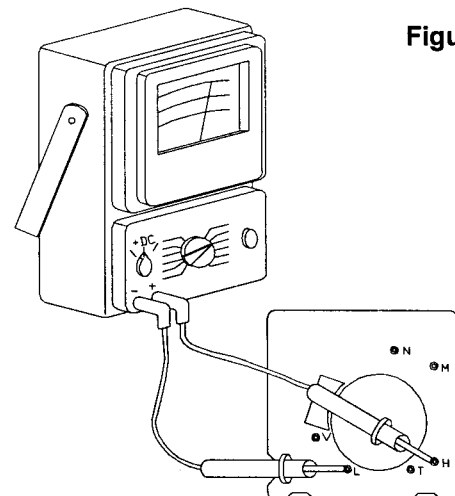

Figure 24

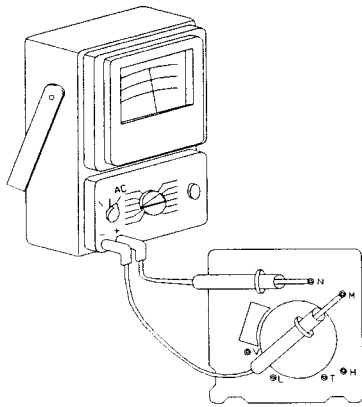

Figure 25

## Motor Check-Out - Figure 10

Use a volt ohmmeter and insert meter leads into test points M & N. 120 volts should be present. If 120 volts is not present, replace the Ice Maker assembly.

## Testing Motor and Cycle Function

This test procedure is to be performed while the ice maker is dry and at room temperature.

The test cycle will take approximately 3-7 minutes to complete. During the cycle the shut-off arm will raise and lower slowly while the mold heater is on and the ejector mechanism simulates ejecting the ice. Approximately 3/4 through the cycle, the water valve will energize for 7 seconds, allowing water (if available to the valve) to fill the ice maker mold cavity.

**Note:** If water is available to the water valve, performing the procedure below may overflow the ice maker's mold.

To perform this test:

**Caution:** To prevent an electrical shock, use an insulated jumper wire.

1. Insert an insulated jumper wire between and into test points T & H. Within 15-20 seconds an audible click will be observed indicating the start of the ice ejection cycle. **Remove the insulated jumper wire once the cycle begins.**
2. If an audible click is not heard, start with the "Wire Harness Check" procedure to locate the problem.
3. If an audible click is heard, the ice maker assembly is functional and does not require repair.

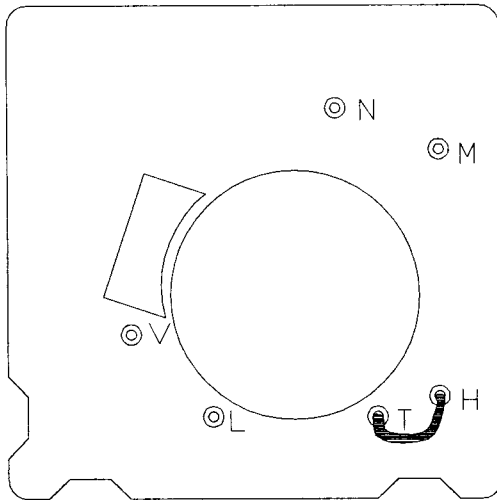

Figure 25



## **Ice Maker Wiring Harness 0. Removal Procedure**

### **Rear of Refrigerator:**

1. Turn off LP Gas at main tank.
2. Disconnect 12 volt DC supply wires to the refrigerator.
3. Disconnect AC power cord from electrical outlet.
4. Using two wrenches, disconnect LP Gas supply line from the refrigerator's gas valve.
5. Disconnect AC power cord from power board.
6. Remove mounting screws at rear of the refrigerator.
7. Disconnect water supply line to water valve of refrigerator.

### **Front of Refrigerator**

Remove Ice Maker to gain access to wire harness.

7. Remove the ice bin and shelf.
8. Remove the two 5/16" mounting screws.
9. Using a Phillips screwdriver, remove the two screws under the ice maker.
10. Pull Ice Maker forward.
11. Remove white cover plate.
12. Depress wire harness clip and remove wire harness from head of Ice Maker.
13. Remove Ice Maker from freezer.
14. Remove 6 mounting screws from front of the refrigerator.
15. Slide refrigerator forward and remove from enclosure.
16. Disconnect Ice Maker wire harness from back of refrigerator.
17. Remove wire ties from Ice Maker wire harness.
18. Pull wire harness to remove from inside of freezer.
19. Discard defective wire harness.
20. Install replacement wire harness by reversing removal procedure.

## Component Check Out Procedures

Figure 27

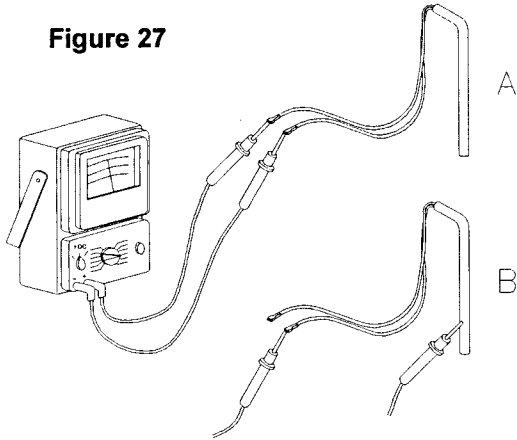

### AC Heaters - Figure 27

A. Measure resistance through each AC heater using an ohmmeter. The resistance should read:

1. Each AC Heater - 24..5 (48.9 total) ohms +/- 5%.

B. Measure the resistance between each heater lead and the metal case of the heater. If any reading is observed, replace heater.

Figure 28

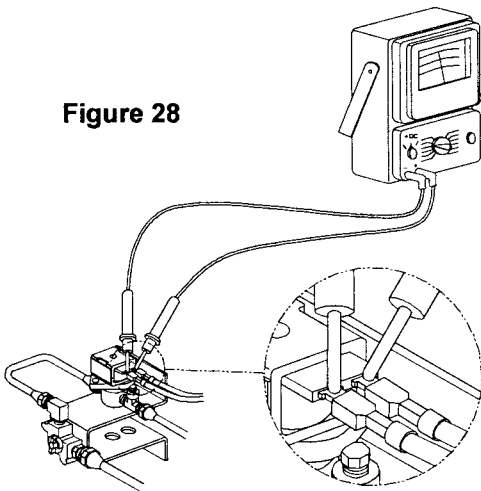

### Gas Valve - Figure 28

1. During a trial for ignition, measure for 12 volt DC at the gas valve. If 12 volt DC is not present, check:

A. Connection of the gas valve wires at the power board. Secure if loose.

B. Continuity of the gas valve wires. Replace gas valve wires if no continuity.

C. If 12 volt DC is not present at the gas valve terminals replace power board.

D. If 12 volt DC is present, replace gas valve.

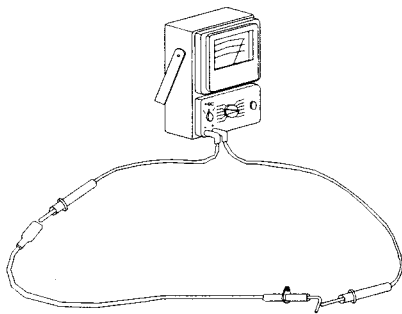

### Sense/Ignition Electrode Wire - Figure 29

1. Turn the refrigerator off.

2. Disconnect the sense/ignition electrode wire from the power board.

3. Measure continuity of the sense/ignition electrode wire. If no continuity, replace sense/ignition electrode wire.

4. Check the sense/ignition electrode for a short to ground. Replace the sense/ignition wire if a reading is observed.

Figure 29

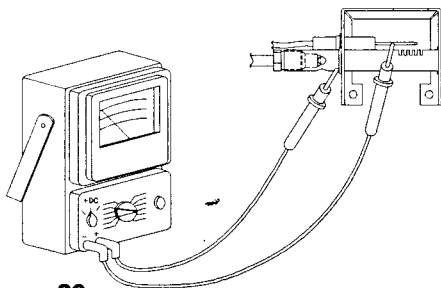

## Sense/Ignition Electrode Alignment Figure 30

The alignment of the electrode is to be between 1/8"-3/16" from the top of the burner.

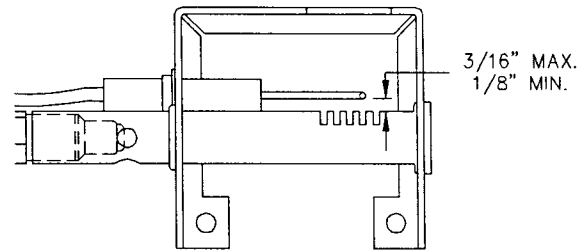

Figure 30

## Burner Flame Appearance-Figure 19

A visual check of the burner flame should be made regularly. The flame should be sharp blue with a stable burning appearance. If there is a constant yellow component observed or if the flame appears erratic or unstable, the burner and burner orifice must be cleaned.

## Burner Orifice Removal and Cleaning Figure 31 & 32

1. Turn off the gas at the main tank.
2. Turn the refrigerator off.
3. Remove the screws securing the burner cover and burner box to the refrigerator.
4. Remove screw securing drip cup. Remove burner cover, burner box, and drip cup.
4. Loosen the flare nut and remove the burner tube from the orifice. ***To prevent damage to the gas line, use two wrenches when loosening the flare nut.***
5. Carefully remove the gas tube from the burner.
6. Remove the orifice and clean with alcohol and air pressure (80 psi max)
7. Remove the screw securing the burner to the burner bracket. Remove the burner.
8. Use air pressure to remove dust, spider webs, etc., from inside the burner. Clean the ports of the burner with a brush.
9. Clean and inspect the ignition/sense electrode. Replace if corroded, cracked, or broken.
10. Using air pressure, clean any debris from burner bracket of cooling system.
11. Thread orifice into the burner until finger tight. Tighten additional 1/4 turn with wrench. Thread flare nut to orifice. ***Do not cross-thread connections. To prevent damage, use two wrenches when tightening.***
12. Leak test all fittings using a soapy water solution. ***Do not use a solution which contains ammonia. Ammonia will attack the brass fittings of the burner and gas valve assemblies. Do not leak test fittings with an open flame.***

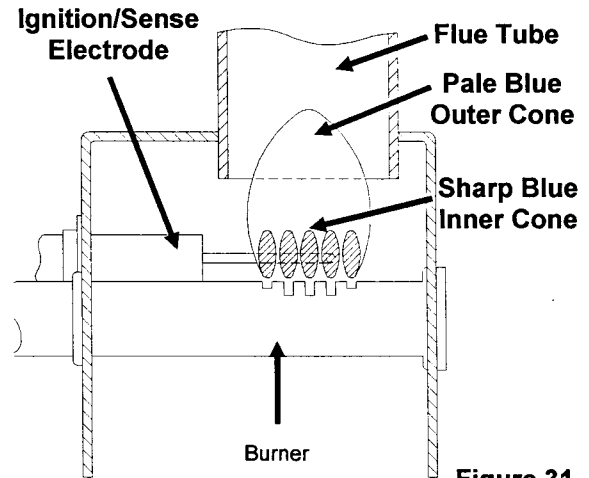

Figure 31

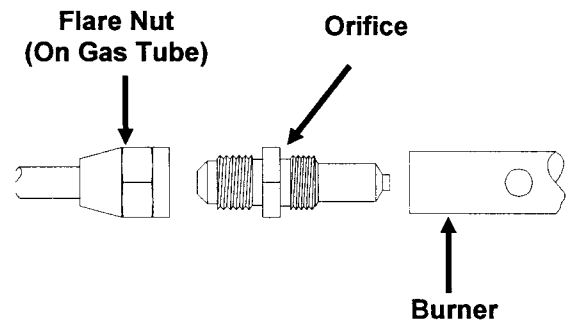
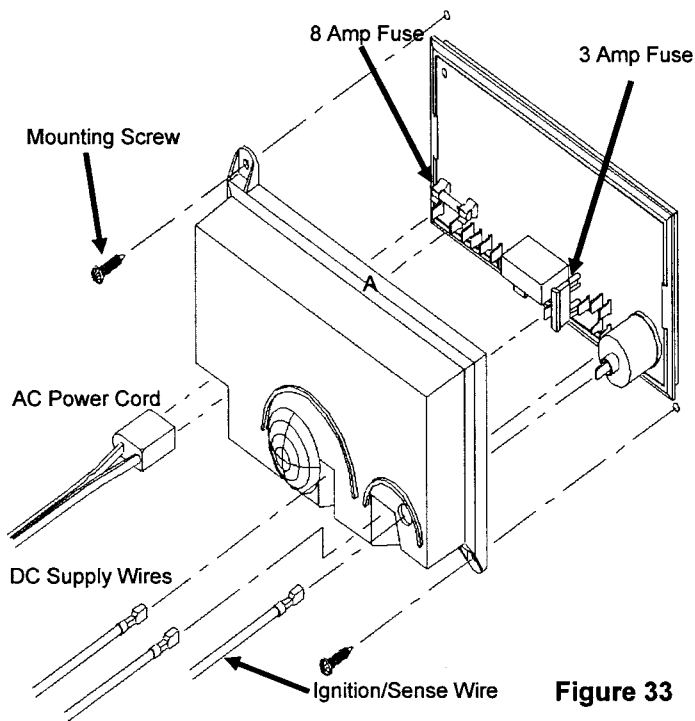

Figure 32

## Fuse Replacement Procedure



**WARNING** A circuit overload can result in an electrical fire when incorrectly sized fuses are used. Follow the fuse specifications given below:



**Figure 33**

### IMPORTANT

- Replace blown fuse with fuse specified by Norcold.
- DC Control Circuit - 3 amp (purple) blade-type automotive
- AC Circuit - 8 amp glass cartridge
- Do not operate refrigerator without the power board cover or the DC module cover.
- Reattach all wires to same location as they were before removed.

1. Turn refrigerator off.
2. Disconnect AC power cord from wall receptacle.
3. Disconnect AC power cord from power board cover (A) at rear of refrigerator.
4. Disconnect 12 volt DC supply wires from power board cover.
5. Remove ignition wire/sense wire from power board cover and pull cover away.

6. Remove three screws which secure power board cover and pull cover away.

**Note: Ice Make Models may require removal of water valve.**

7. Replace a blown fuse with fuse specified by Norcold. (See IMPORTANT under illustration or refer to SPECIFICATION section.

8. Re-install power board cover and secure with screws.

9. Re-install ignition/sense wire, 12 VDC supply wires, and AC power cord to power board.

10. Connect AC power cord to wall receptacle.

11. Turn refrigerator on.

### Retractable Door Seal Removal

1. Open left fresh food compartment door.
2. Open retractable door seal 90°.
3. Using a phillips screwdriver, remove the six hinge screws securing the retractable door seal to the fresh food compartment door.
4. Grasp the two white wires of the moisture reduction heater.
5. Carefully pull the wires down and away from the retractable door seal body.
6. Disconnect the wires at connector.
7. Install retractable door seal by reversing the above procedures.

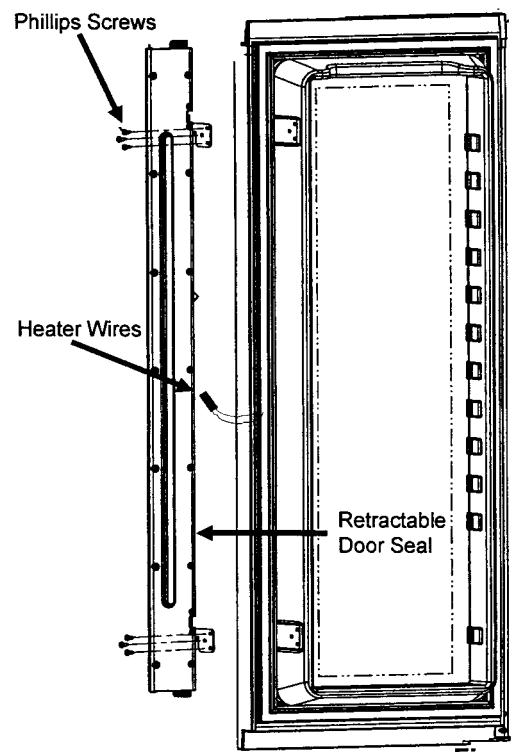

Figure 34

### Door Handle Removal

1. Using phillips screwdriver, remove the two screw inside handle assembly.
2. To remove, Pull handle assembly up and away from fresh food compartment doors, or down and away from (freezer doors).
3. To re-install, reverse above procedure.

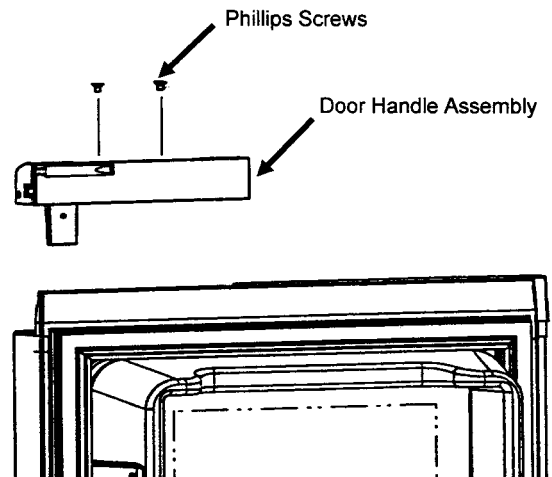
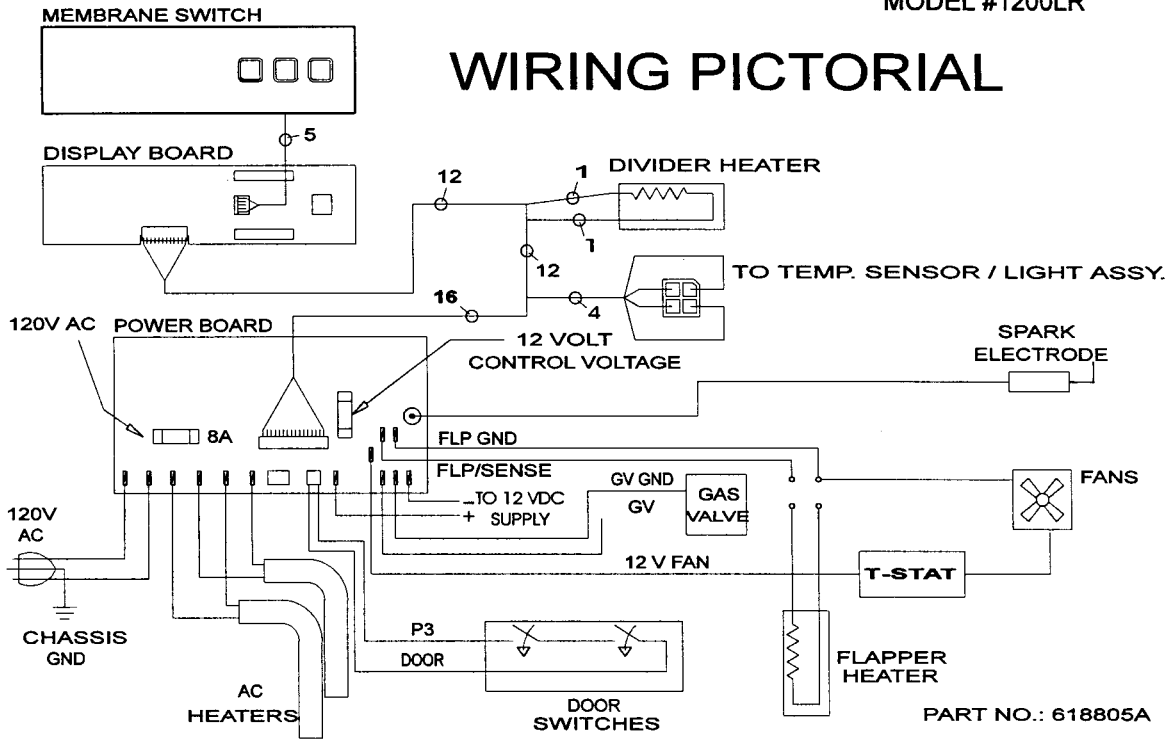
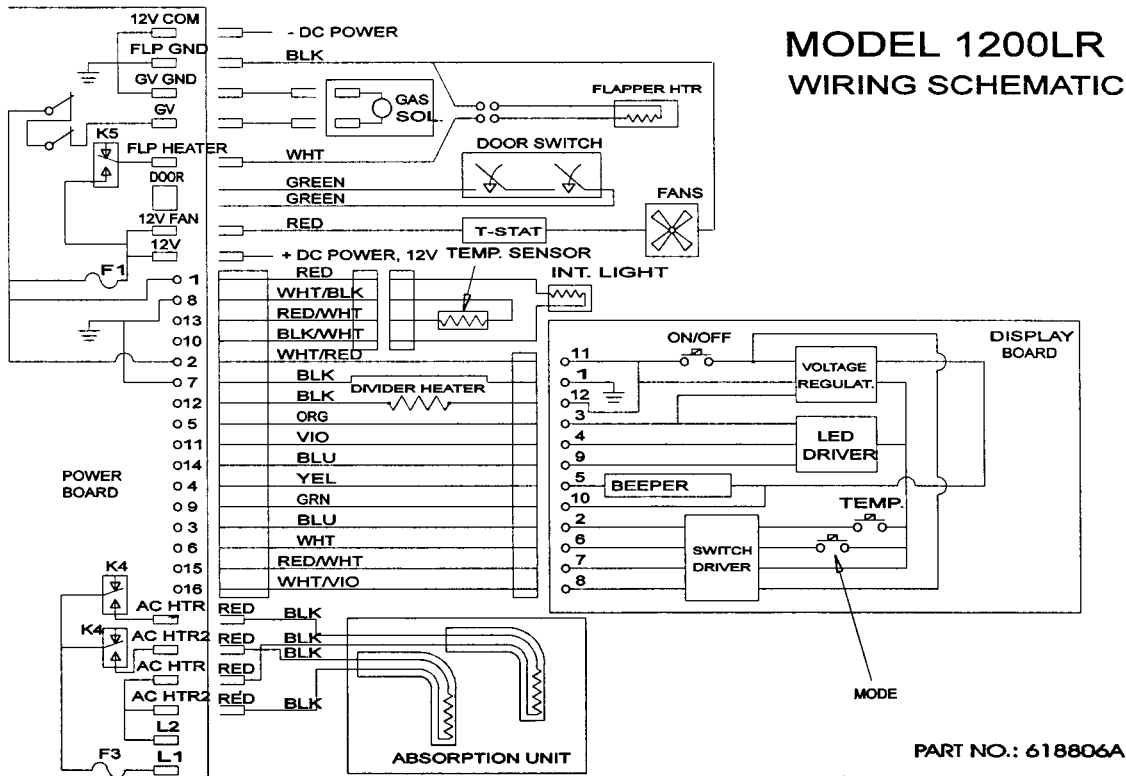

Figure 34

# WIRING PICTORIAL



# MODEL 1200LR WIRING SCHEMATIC



# Ice Maker Pictorial and Wiring Schematic

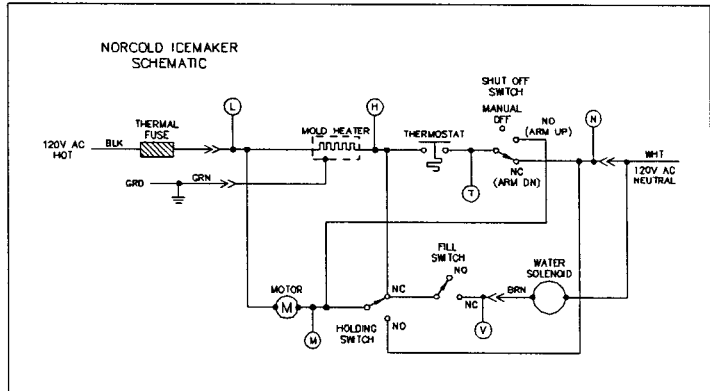
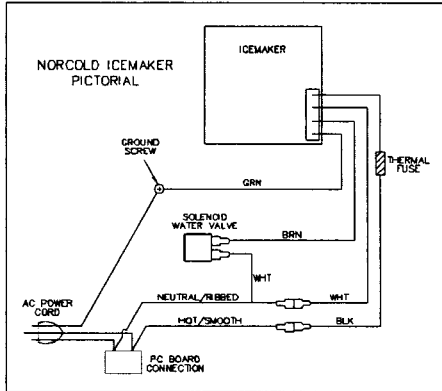

Manual provided courtesy  
Bryant RV Services  
[www.byantrv.com](http://www.byantrv.com)

All manuals are believed to be released for distribution, and/or in the public domain.

Service manuals provided with the understanding that persons using them are well versed in proper safety practices, and are familiar with basic safety procedures, including, but not limited to safety procedures dealing with 120 volt electricity, high amperage 12 volt circuits an LPG (propane) systems.

If in doubt, consult a professional (better safe than sorry).