



RECORD THIS UNIT INFORMATION FOR FUTURE REFERENCE:
 Model Number _____
 Serial Number _____
 Date Purchased _____

POWER

Patio Awning

895(X)0(X)1.400(X) Basement Hardware
 895(X)0(X)2.400(X) Standard Hardware
FOR

915(XX)(YY).000(#)
 916(XX)(YY).000(#)
 917(XX)(YY).000(#)

Fabric Roller Tube Assembly

USA
 SERVICE OFFICE
 Dometic, LLC
 2320 Industrial Parkway
 Elkhart, IN 46516
 574-294-2511

CANADA
 Dometic, LLC
 46 Zatonski, Unit 3
 Brantford, ON N3T 5L8
 CANADA
 519-720-9578

For Service Center Assistance Call:
 800-544-4881

⚠ WARNING

This manual must be read and understood before installation, adjustment, service, or maintenance is performed. This unit must be installed by a qualified service technician. Modification of this product can be extremely hazardous and could result in personal injury or property damage.

⚠ AVERTISSEMENT

Lire et comprendre ce manuel avant de procéder à l'installation, à des réglages, de l'entretien ou des réparations. L'installation de cet appareil doit être effectuée par un réparateur qualifié. Toute modification de cet appareil peut être extrêmement dangereuse et entraîner des blessures ou dommages matériels.

INSTALLATION INSTRUCTIONS

Model
 915(XX)(YY).000#
 916(XX)(YY).000#
 917(XX)(YY).000#
FRTA
 895(X)0(X)(X).400(X)
Hardware

REVISION:
 Form No. 3312737.038 4/10
 (Replaces 3312737.020)
 (French 3312738.036)
 ©2010 Dometic, LLC
 LaGrange, IN 46761

Important: These Instructions must stay with unit. Owner read carefully.

SAFETY INSTRUCTIONS

This manual has safety information and instructions to help users eliminate or reduce the risk of accidents and injuries.

RECOGNIZE SAFETY INFORMATION



This is the safety-alert symbol. When you see this symbol in this manual, be alert to the potential for personal injury.

Follow recommended precautions and safe operating instructions.

UNDERSTAND SIGNAL WORDS

A signal word, **WARNING OR CAUTION** is used with the safety-alert symbol. They give the level of risk for potential injury.

WARNING indicates a potentially hazardous situation which, if not avoided, could result in death or serious injury.

CAUTION indicates a potentially hazardous situation which, if not avoided, may result in minor or moderate injury.

CAUTION used without the safety alert symbol indicates, a potentially hazardous situation which, if not avoided, may result in property damage.

Read and follow all safety information and instructions.

REQUIRED PARTS: (Packed with each Hardware Assembly)

- 895(X)0(X)1.400(X) & 895(X)0(X)2.400(X) Hardware
- (4) Mounting Bracket (3310250.000(X))
 - (8) #14-10 x 1-1/2" Hex Head Screw (3104499.003)
 - (2) .25" Split Lock Washer (3101746.000)
 - (8) 3/16" x 1" Oscar Rivets (113008)
 - (2) #6-20 x .44" Hex Washer Head Self Drilling Screw (310359.012)
 - (2) 1/4" - 20 x 3/4" Hex Head Bolts (3104176.205)
 - (1) Optional Ignition Interlock Kit (3313283.008)

Important: Read and understand ALL of the following steps before beginning installation.

Application

The Power Patio Awning is designed and intended for use on Motorhomes, Travel Trailers and Fifth Wheels with straight sides.

Important: Structural backing is required where mounting screws /oscar rivets will be installed through sidewall for securing top mounting brackets and back channels.

Important: Follow the Minimum distance dimensions requirements from awning rail to door. Mounting height depends on awning type and length. Insure sufficient room is available before starting installation. This awning is not intended to be mounted over a slideout room.

Hardware Model	Minimum Distance
895(X)0(X)1.400(X)	12"
895(X)0(X)2.400(X)	7"

When the door falls in the center of the awning, add 2" to these distances.

Installation Height: This is the center to center distance of mounting holes in the top mounting bracket and the back channel. See Specification chart and illustrations on page 3.

Dometic, LLC reserves the right to modify appearances and specifications without notice.

Specification Chart		
	895(X)10(X)1.400(X)	895(X)0(X)2.400(X)
A	62 3/4"	66-7/8"
B	60-3/4"	64-1/4"
C	61-1/2"	65"
D	3/4"	3/4"
E	60-1/8"	63-5/8"
F	62-1/8"	65-5/8"
G	31"	32-7/8"
H	5/8"	5/8"
J	3/8"	3/8"
K	1/4"	1/4"
L	35-1/4"	N/A

- A= Overall length of hardware
 B= Minimum mounting distance center to center on mounting holes.
 C= Maximum mounting distance center to center on mounting holes.
 D= Distance between mounting holes in bracket.
 E= Distance from top edge of mounting bracket to center of hole for wire harness.
 F= Back channel length.
 G= Distance from top edge of mounting bracket to center of middle mounting hole on back channel.
 H= Distance front channel guard extends past back channel.
 J= Distance from top edge of top bracket and center of first mounting hole.
 K= Distance between edge of back channel and bottom mounting holes.
 L= Distance from top edge of mounting bracket to center of optional middle mounting holes on back channel.

FIG. 1
895(X)00X.400(X) Power Patio awning Hardware

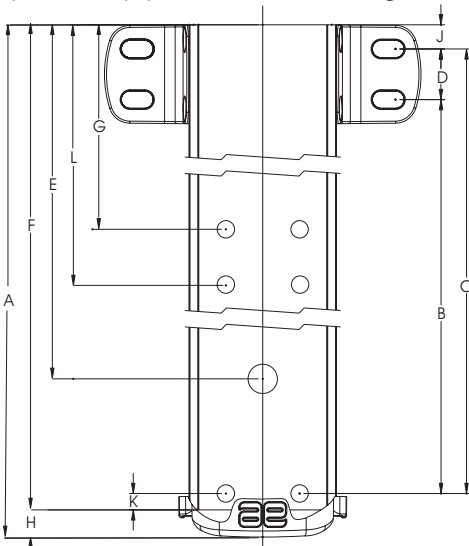

Installation Instructions

Installation of Power Patio Awning will briefly require three people. Use the following procedure to assure a properly installed, and properly functioning awning.

A. Secure FRTA to Hardware

1. Carefully lay the fabric roller tube assembly on a clean, well padded "V" trough to prevent fabric and/or roller cover damage. Remove the hardware from the packaging and place the arm pre-wired for the motor on the right side. The left arm is not pre-wired for the motor.

⚠ WARNING

Personal Injury Hazard. Rapid casting spin off will occur if not controlled. Do not remove cotter pin in end cap until top casting is secured to hardware. Failure to heed this warning could cause severe personal injury.

⚠ WARNING

Personal Injury Hazard. Hardware arms are spring loaded. Rapid arm extension will occur if tie is removed before top casting is secured to hardware. Failure to heed this warning could cause severe personal injury.

2. Secure each front channel to top casting of the FRTA. See FIG. 2. Slide top nylon ties down arm approximately 24 inches to allow hardware to open far enough to insert top casting into front channel. Do not remove nylon ties at this time. The gas shocks on arm assemblies are pressurized and will spring open if not controlled.
3. Using one (1) 1/4"-20 x 3/4" hex head bolt and one (1) 0.25 split lock washer secure both top castings to the right and left front channels. See FIG. 2.
4. Remove cotter pin from LH end cap.

FIG. 2

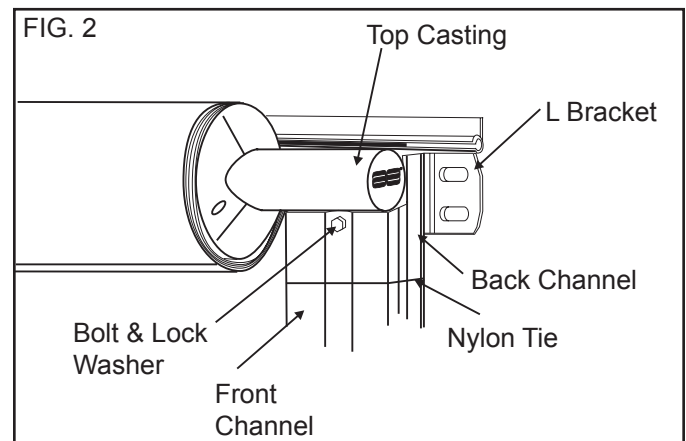

WARNING

Personal Injury Hazard. Rapid casting spin off and rapid arm extension will occur if they are not controlled. Before separating torsion from hardware, the torsion must be pinned through end cap and hardware arms must be bound. Failure to heed this warning may cause severe personal injury or property damage.

B. Install Fabric in Awning Rail

1. Prepare the awning rail to accept the awning fabric.
 - a. Select the end from which the awning shall be fed, then widen that end with a flat screwdriver and file off any sharp edges. See FIG. 3A.

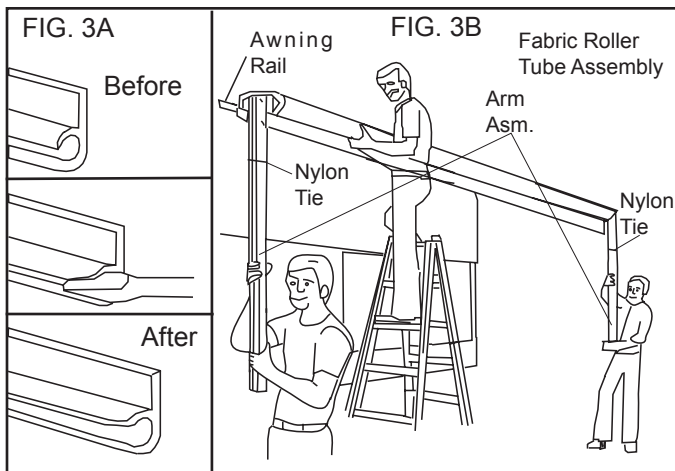

2. Unwind fabric one revolution before feeding awning fabric into awning rail. This will allow enough space between side wall and awning hardware to connect wires in Step D.

Important: Do not remove more than one revolution of fabric.

3. With one person grasping each arm assembly, carefully lift the entire assembly to an upright position.

Important: Keep the two arm assemblies parallel to each other to avoid excessive twisting and possible damage to the assembly.

4. Walk the awning to the end where the awning rail was prepared. A third person is now required to feed the fabric into the awning rail. The other two will walk the entire awning assembly forward and into the desired position. See FIG. 3B.

C. Top Mounting Bracket Installation

1. (895(X)0(X)1 Basement & 895(X)0(X)2 Standard Hardware) Secure Top mounting Brackets
 - a. After the complete awning assembly has been threaded into the awning rail, check that its position allows for solid mounting of the top mounting brackets and the back channels. Also insure that the back channels are in the desired location (not restricting use of doors, access doors, windows, etc.)

Important: Structural backing is required where mounting screws will be installed through sidewall for securing top mounting brackets.

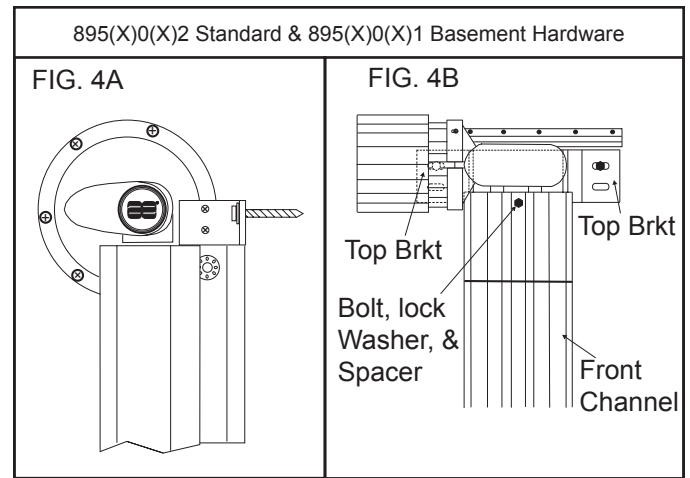

- b. Place both top brackets in position directly under the awning rail as shown in FIG. 4B. The motorized arm assembly is always installed on the right end of the awning.

Top bracket must be installed parallel with the awning rail. Using the outside bracket hole as a guide, pre-drill a 3/16" hole for mounting screw. Drill a 7/32" hole if drilling into steel. Install outside top mounting bracket using one (1) #14-10 x 1-1/2" hex head screw. Seal where the screw enters the side wall with clear silicon sealer. Repeat this procedure for opposite side.

CAUTION

The arm assemblies must be controlled while the top mounting brackets are being installed. When the weight of the FRTA is no longer supported, the downward force could cause the arm assembly to swing side ways and may damage the sidewall if not controlled.

D. Electrical Installation Kits

1. Remote Rocker Switch Kit (3310455.062)
 - a. Installation of Remote Rocker Switch
 - 1.) First, decide on location of the remote rocker switch.
 - 2.) Install the remote rocker switch at a convenient location such as the door area.
 - 3.) The remote rocker switch should not be in direct exposure to weather or extreme temperatures.
 - 4.) Cut hole in structure where remote rocker switch is to be installed. Pop remote rocker switch into bezel opening.
 - b. Low Voltage connection

Note: An inline 15 amp fuse (installer supplied) should be installed between the rocker switch and the 12 VDC power source on the positive (red) wire.

- 1.) Route two (2) wires (red & black installer supplied) from the 12 VDC source to the switch. See FIG. 5.

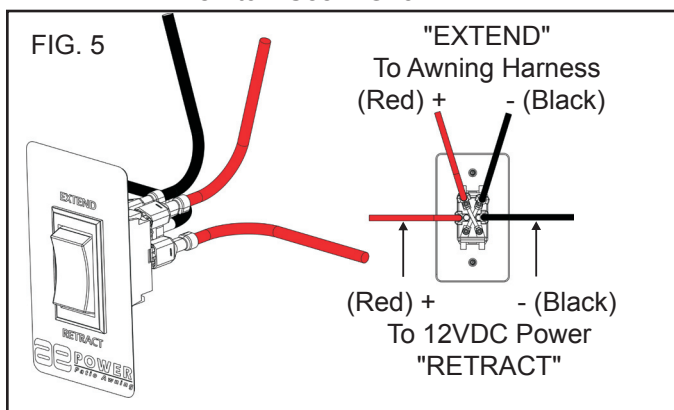

- 2.) Route two more wires (red or white & black installer supplied) from the switch to the right side (motorized) arm assembly. To avoid voltage drop, follow wire length guide in Table 1:

Table1:

Wire Length	Wire Size
10' & Under	14 Gauge
11' to 30'	12 Gauge
Over 30'	10 Gauge

- 3.) Wires connecting to remote rocker switch should be terminated with insulated .25" female tab quick connectors. See FIG. 5 for wire locations.
- 4.) Secure bezel with supplied fasteners.

Important: Make sure channel is in proper position before drilling the 5/8" hole in side wall for wires. See FIG. 1.

- 5.) Connect the wires coming from the rocker switch to the pre-wired arm using (installer supplied) crimp type wire nuts. (red with red and black with black.)
- 6.) When routing harness, take precaution against wires rubbing on sharp edges and use a grommet when going through walls. Harness should be routed so that when back channel is attached to the wall, it will align with channel hole or notch where wire goes through wall. Seal any holes with clear silicon sealer. See FIG. 1.

Important: The awning is now operational. Do not move vehicle until Steps E & F are completed.

2. Ignition Interlock Kit Option (3313283.008)

Note: The ignition interlock will be required for installation of the Power patio awning onto motorized recreational vehicles (Class A/B/B+/C/C+).

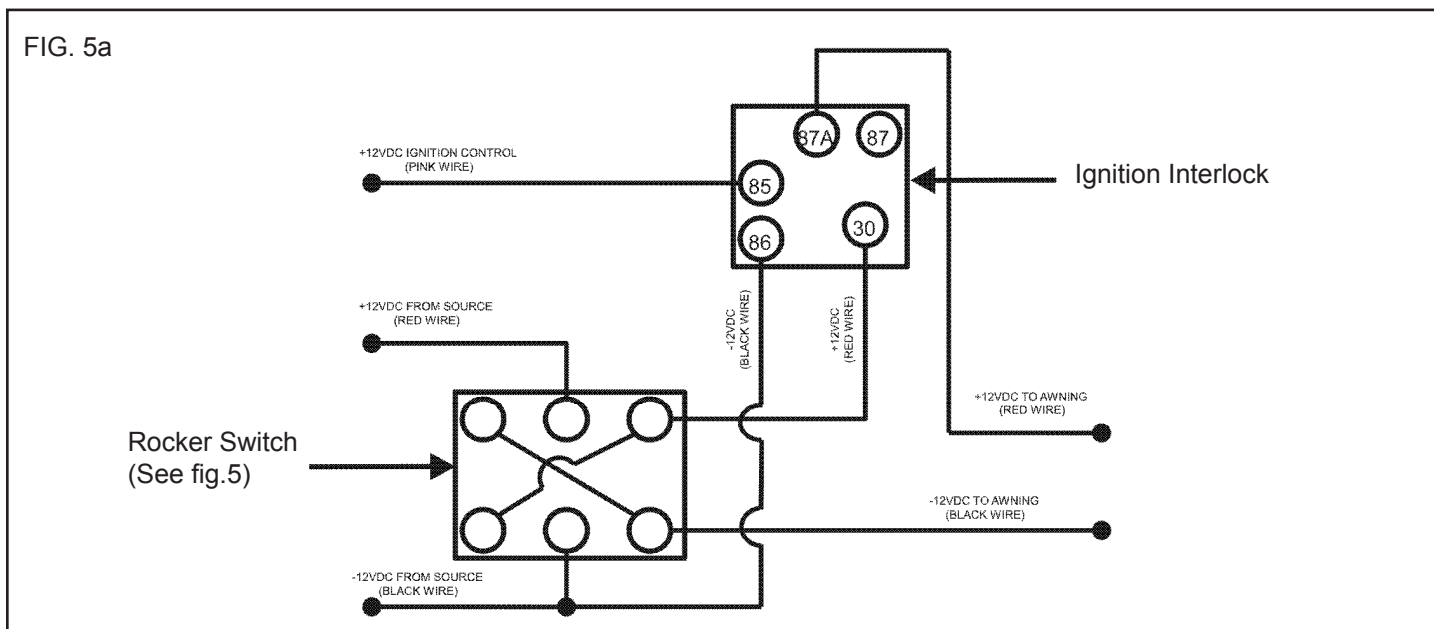

- a. Installation of Ignition Interlock.
 - 1.) First, decide on location for ignition interlock placing it as close as possible to either the 12VDC source or the rocker switch to minimize the total circuit wiring.
 - 2.) Measure length of wire needed for installation and check wire length table guide in D.2.b.2.) section for proper wire gauge.
 - 2.) Turn engine off and remove key from ignition.
 - 3.) Install ignition interlock and connect wires as shown in diagram. See FIG. 5a.

E. Back Channel Installation

Important: Flat solid structure backing (3/8" to 1/2" thick) is required where oscar rivets (supplied) will be installed through sidewall for securing back channels. Solid wood block is required if using wood screws (not supplied).

1. Open awning as required to secure back channel.
2. Align the back channel so it is square with the vehicle and the FRTA. A door or window frame can be used to measure from. See FIG. 6.
3. Drill four (4) 3/16" holes through the outside wall using the holes on the back channel as a guide. See FIG. 1.
4. Secure each back channel to wall with four (4) 3/16" x 1" oscar rivets provided, 2 rivets at middle and 2 rivets at bottom. Be careful not to pinch or damage motor wire when securing channel to wall. See FIG. 6. Depending on your model, wire covers may need to be removed to access back channel holes.

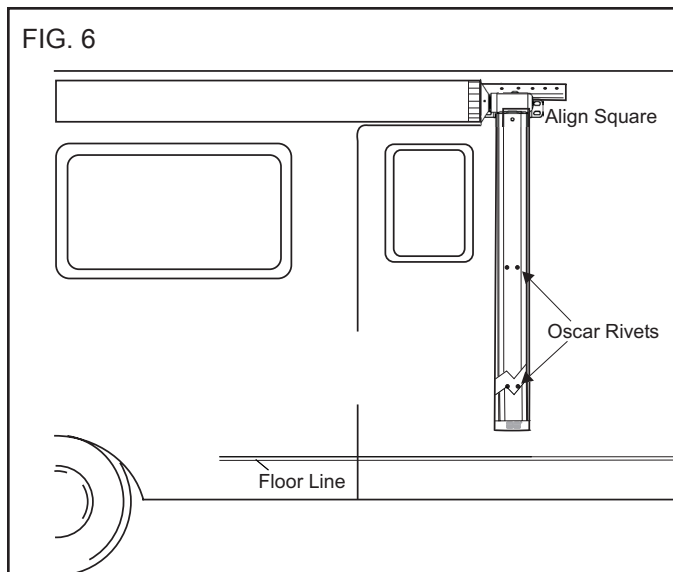

Important: Flat solid structure backing (3/8" to 1/2" thick) is required where oscar rivets (supplied) will be installed through sidewall for securing back channels. Solid wood block is required if using wood screws (not supplied).

5. Seal where the oscar rivets enter the vehicle with clear silicon sealer.
6. To install screws on the inside top mounting brackets it will be necessary to pull the FRTA away from the side wall approximately 12". Remove nylon ties wrapped around the front and back channels. See FIG. 4B. Grasp the front channel and slowly pull it away from the sidewall. Pre-drill hole as in previous step and install one (1) #14-10 x 1-1/2" hex head screw. Repeat this procedure for opposite side. Seal where screw enters the side wall with clear silicon sealer.
 - Connect the motor wire to the factory pre-wired hardware wiring. See FIG. 7.

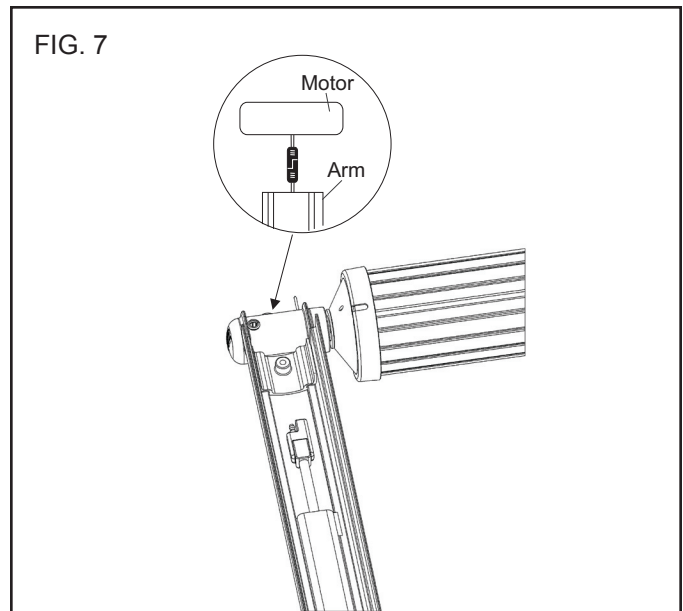

F. Initial Awning Adjustment

Important: Rapid cycling of the awning (opening & closing) can cause the motor to over heat. Allow 2-3 minutes between cycles.

1. Cycle the awning four or five times to check fabric alignment and to make sure the hardware is nesting properly. If there is a misalignment, adjust the arm by loosening the upper mounting bolts and move the bracket accordingly. Cycle the awning again to check the alignment. See User's Guide for opening and closing instructions.

Note: Press rocker switch until awning is fully extended or retracted. If switch is released awning should stop extending or retracting. If not, more than one wrap of fabric was unwound during installation. See Section H for corrections.

2. When satisfied with the alignment, secure fabric roller cover by driving a #6-20 x .44" TEK screw through the rail and into the fabric rope. See FIG. 8 for screw location. Repeat at opposite end. Snap the back channel wire cover in place. The installation is now complete and ready for use.

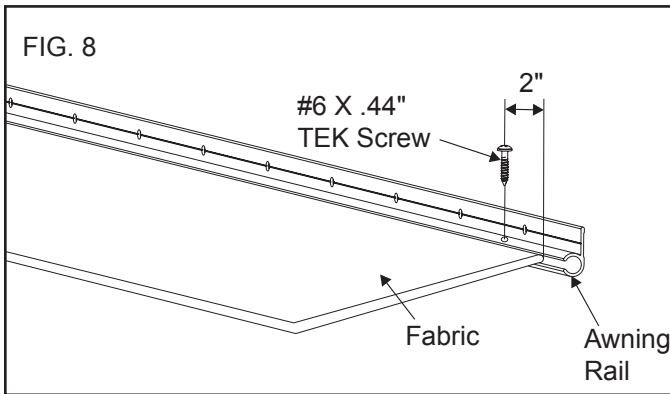

G. Close and Secure Awning

1. If awning will not be used after installation, close and secure. See User's Guide for closing and securing instructions.

H. Increasing Turns on Left Hand Torsion

⚠ WARNING

Use extreme care. Springs under tension are dangerous. If not controlled they will unwind quickly. Keep hands and clothing clear of top casting, as personal injury may result.

Note: If the awning is installed on a coach, complete the following steps on a step ladder with the FRTA extended two turns from the awning rail.

⚠ WARNING

Severe injury can result from the rapid spin-off of the top casting. NEVER use bare hands to handle a top casting under spring tension.

1. Before the left arm assembly is removed the torsion must be pinned to prevent uncontrolled unwinding of the spring.
 - a. Turn top casting or FRTA until the pin is parallel with the two slots in the end cap. See FIG. 9.
 - b. To pin the left hand torsion insert a 7/64" x 2-3/4" cotter pin through the end cap and torsion rod. Put a piece of tape over the head of the cotter pin to prevent it from dropping out. See FIG. 9.
- Note:** Do step "c" if FRTA is installed on coach. If not installed on coach proceed to step "d".
- c. Insert a wood block, between front and back channel to space the FRTA 2 - 3 inches from the coach. Push arm assembly closed. Wrap a nylon wire tie around arm to keep it from extending.
 - d. Remove Hex Head 1/4-20 x 3/4" screw that attaches arm assembly to top casting. Lift casting out of arm assembly.

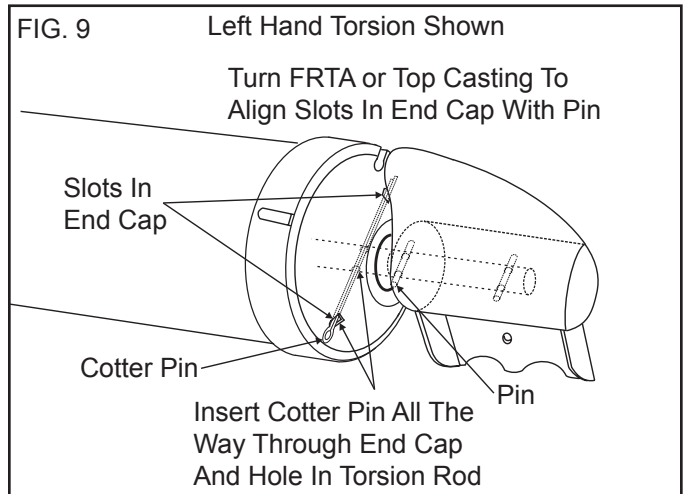

- e. Attach crank adapter (3308335.011) with 1/4-20 screw and pin crank (3308335.003) as shown on FIG. 10. (Crank & adapter supplied in 3308334.006U Torsion Winder Kit.)

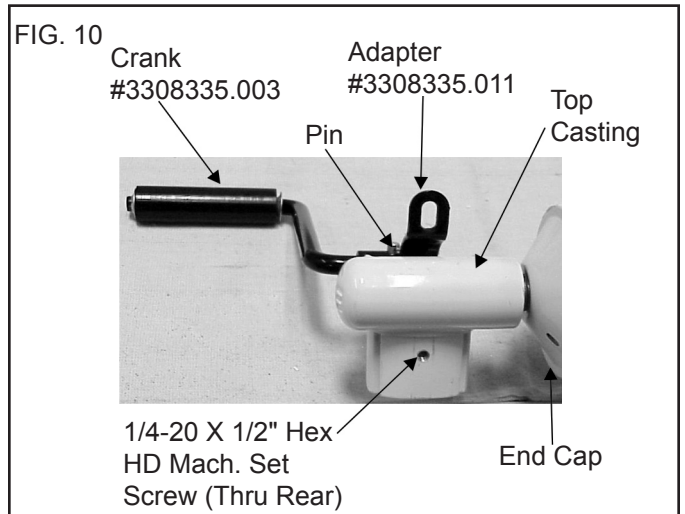

- f. Keep a tight hold onto the crank while the cotter pin is pulled out of the end cap.
- g. Slowly unwind spring tension by allowing the spring to unwind counter clockwise. Torsion will want to unwind by itself. Caution should be taken to prevent rapid unwind.
- h. Once spring is free, position of top casting should be noted for starting position.
- i. Slowly wind the spring tension clockwise eight (8) complete turns.
- j. Reinsert cotter pin through end cap and torsion rod. See FIG. 9.
- k. Remove crank from top casting in arm assembly.
- l. Reinsert top casting into arm assembly.
- m. Replace hex head 1/4-20 x 3/4" screw that attaches arm assembly to top casting.
- n. Remove nylon tie and wood block.
- o. Remove cotter key before attempting to operate awning.
- p. Cycle the awning again and verify awning stops extending when switch is released.