

## Dometic WeatherPro / Power Patio Awning Electric Drive Motor Testing

### ATTENTION SERVICE TECHNICIANS:

The purpose of this Bulletin is to alert you to the proper testing procedure of the DC drive motor on Dometic electric patio awnings.

### BULLETIN INSTRUCTIONS

This manual has safety information and instructions to help users eliminate or reduce the risk of accidents and injuries.

### RECOGNIZE SAFETY INFORMATION



This is the safety-alert symbol. When you see this symbol in this manual, be alert to the potential for personal injury.

Follow recommended precautions and safe operating instructions.

### UNDERSTAND SIGNAL WORDS

A signal word, **WARNING** OR **CAUTION** is used with the safety-alert symbol. They give the level of risk for potential injury.

**! WARNING** indicates a potentially hazardous situation which, if not avoided, could result in death or serious injury.

**! CAUTION** indicates a potentially hazardous situation which, if not avoided may result in minor or moderate injury.

**CAUTION** used without the safety alert symbol indicates, a potentially hazardous situation which, if not avoided may result in property damage.

Read and follow all safety information and instructions.

**This bulletin must be read and understood before performing test on the awning. The testing must be performed by a Dometic Service Center or a qualified service technician. Modification of this product can be extremely hazardous and could result in personal injury or property damage.**

# Dometic WeatherPro / Power Patio Awning Electric Drive Motor Testing

## A. GENERAL INFORMATION

The motor should draw approximately 2 to 3 DC amps opening and approximately 4 to 5 DC amps when closing. The control box has current (AMP) sensing technology that will limit the max amps the motor can draw.

### Tools Required:

- Step Ladder
- DC power supply 10 amp minimum at 12.5 Volts
- Volt meter
- Hand tools
- DC Amp meter or amp gauge
- Lubricant

## B. BEFORE TESTING MOTOR

1. Measure DC volts at control box while operating awning. If the volts are below a minimum of 12.5 , correct power supply. The gauge of the wire must be large enough to eliminate voltage drop.

Wire Length	Wire Size
10 foot & under	14 Gauge
11 foot to 30 foot	12 Gauge
Over 30 foot	10 Gauge

2. Open the awning fully and check if fabric has shifted at rail, roller tube or aluminum guard. If fabric has shifted correct it before testing the motor. A fabric that has shifted will cause the motor to pull excessive amps when awning is closing.
3. Check the spring tension on the left torsion. Low tension on the spring will create higher than normal amp draw on the drive motor when retracting the awning.
4. If the hardware is mechanical bound or binding the amp draw will be higher than normal
5. The motor assembly used on the electric awning has an internal brake which prevents the roller tube assembly from rotating. When DC power is sent to the motor drive the brake is released and then the power goes to the DC motor. A sticking brake will cause the motor to amp out and not move. The amps through the control are limited to approximately 6.2 to 7 amps. By-passing the control and sending voltage straight to the motor should allow the brake to break loose. If the customer is in a high humidity area and the awning has not been used for while the brake may stick .

**Note:** Dometic uses four different control configurations for the WeatherPro / Power Patio Awnings. The first control has 5 molded rubber plug harnesses coming out of a strain relief. (Fig. 1) The second has one (1) 15 pin MATE-N-LOK® with 13 wires going to the strain relief and it has a 4 pin connector used in the wind sensor cable. (Fig. 2) The third control has 7 molded connectors on the electronic control box. (Fig 3) The fourth control uses a single rocker switch. (Fig. 4)

## 1.0 DC Volts

To ensure proper operation, the control box must have a minimum of 12.5 VDC at the control box during operation. Check voltage input on the Red and Black wire at the control. If voltage is below 12.5, check voltage at supply, If OK it may be necessary to increase the wire size going to the control box.

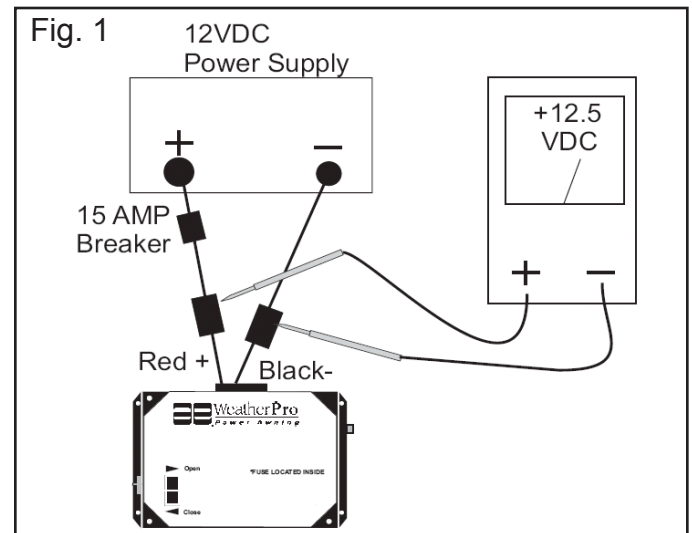

If the control is part number 3307930 & 3309114 the voltage can be checked on pins 1 and 2 of the 15 pin MATE-N-Lock plug. Pin 1 is DC+ and pin 2 is DC-.

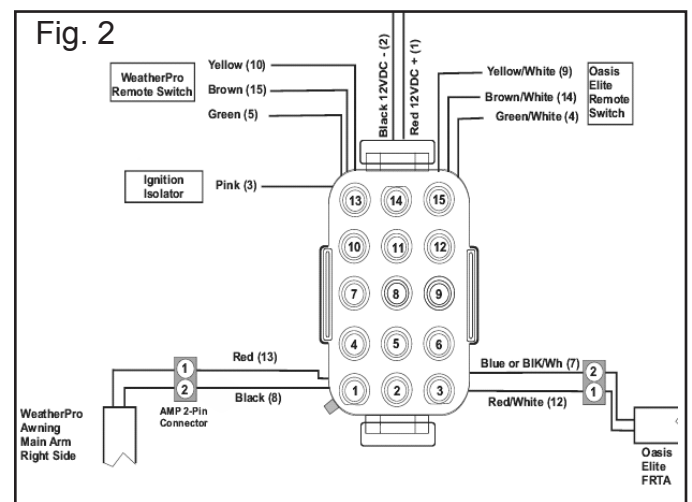

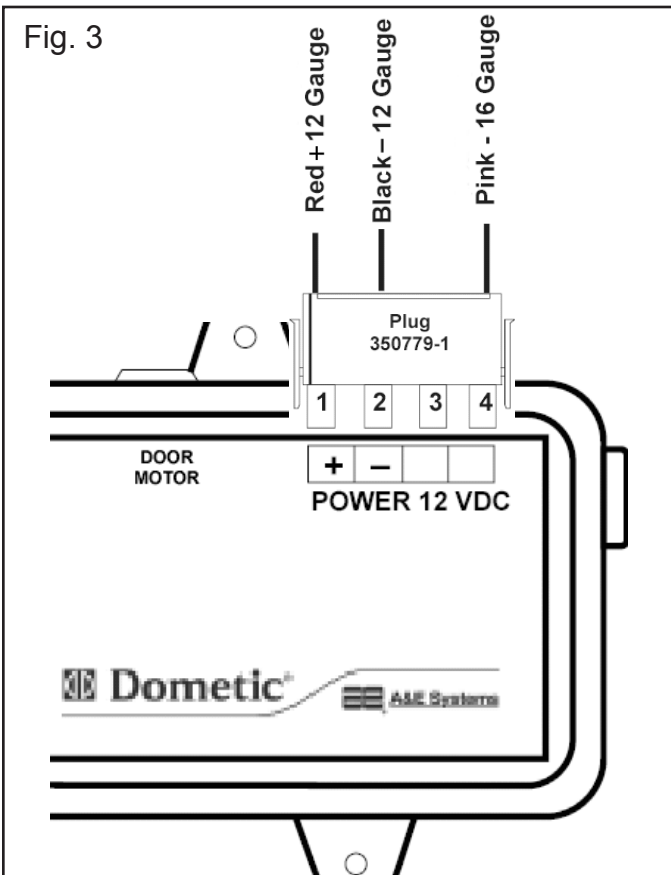

Remote Rocker Switch Kit (3310455.062)

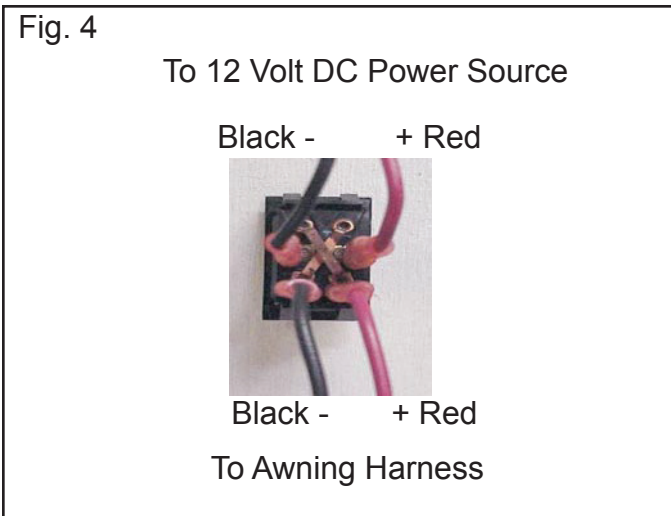

**2.0 DC Amp Draw**

To check the amp draw on the motor use a DC amp meter. You can also use a DC power supply with minimum 10 amp and gauge. The amp reading can be done at the top of the awning arm or at the control box.

**2.1 Amp Draw At Motor**

At the top casting there is a two pin connection for the motor. Open the awning approximately 10 to 12 inches and unplug the drive motor.

**WARNING**

Do not attempt to separate the FRTA from the hardware arm unless the torsion assembly is pinned and hardware arm assemblies are tied. The FRTA is under spring tension and rapid spin off will occur if separated. The hardware arm assemblies have pressurized gas shock and it will spring open. Failure to follow these instructions could cause serious personal injury or property damage.

**WIND SENSOR ON ARM**

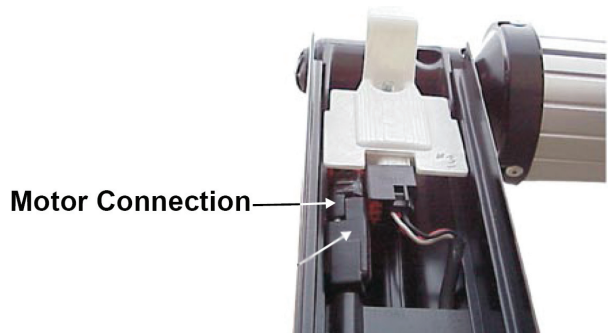

**WIND SENSOR ON ROOF / POWER PATIO AWNING**

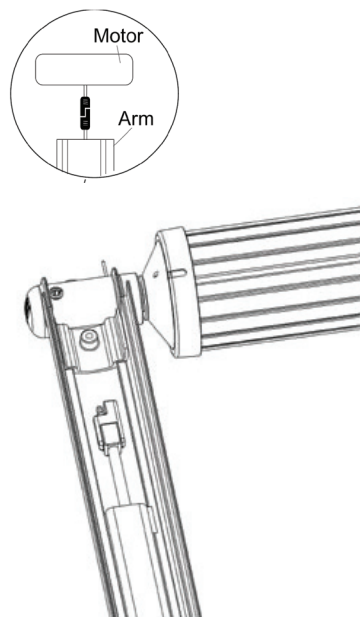

Apply 12 volt to the two pin connector at the motor and monitor the amp draw extending and retracting. The motor should draw approximately 3 amps extending and 4.5 amps retracting plus or minus 1/2 amp. If the amp draw exceeds 6.5 amps the motor is out of specification. Units with an electronic control box have current ( AMP ) sensing technology that will limit amp draw on the motor to approximately to 6.5 to 7 amps.

## 2.0 DC Amp Draw At Motor Continued

**Note:** Since the electronic controls box have been completely bypassed, the motor will not shut down but will continue to operate as long as power is applied. On the Power Patio Awning there is only a rocker switch to control the power to the motor. As long as you hold the rocker switch down, power will be sent to the motor. When finished taking amp draw reconnect the drive motor plug.

## 2.2 Amp Draw At Control Box

Apply 12 volt to the motor connector from the control box out to the motor and monitor the amp draw extending and retracting. The motor should draw approximately 3 amps extending and 4.5 amps retracting plus or minus 1/2 amp. If the amp draw exceeds 6.5 amps the motor is out of specification. When the awning reaches the end of travel ( **FULLY OPEN OR FULLY CLOSED** ) the control box will sense high amperage and shut down. This is normal. On the Power Patio Awning there is only a rocker switch to control the power to the motor. As long as you hold the rocker switch down, power will be sent to the motor.

## Wind Sensor On Roof Control

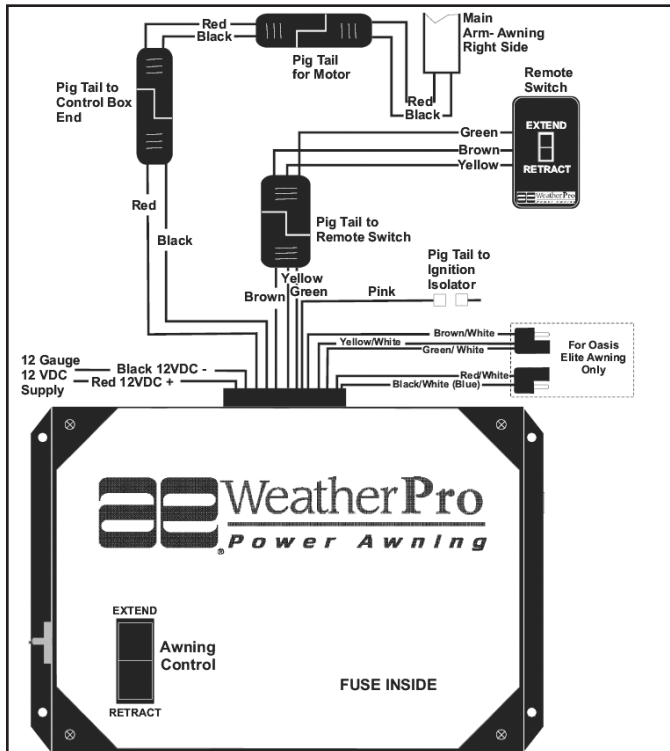

To 12 Volt DC Power Source  
Black -      + Red

## Remote Rocker Switch

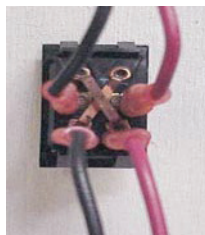

Black -      + Red  
To Awning Harness

## 15 Pin MATE-N-LOCK Plug

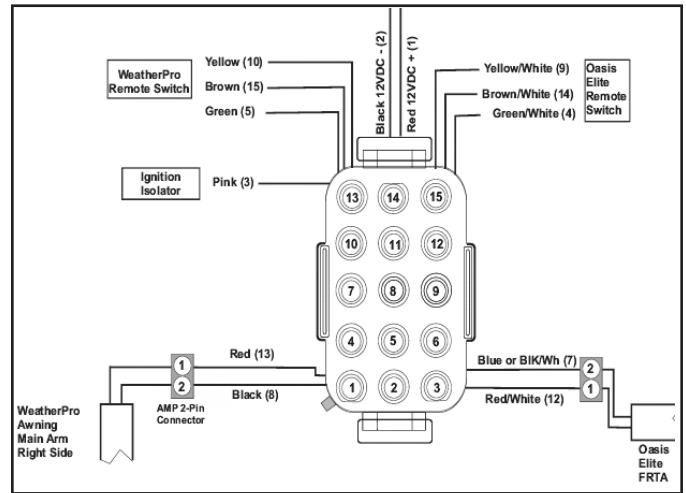

## Wind Sensor In Arm Control

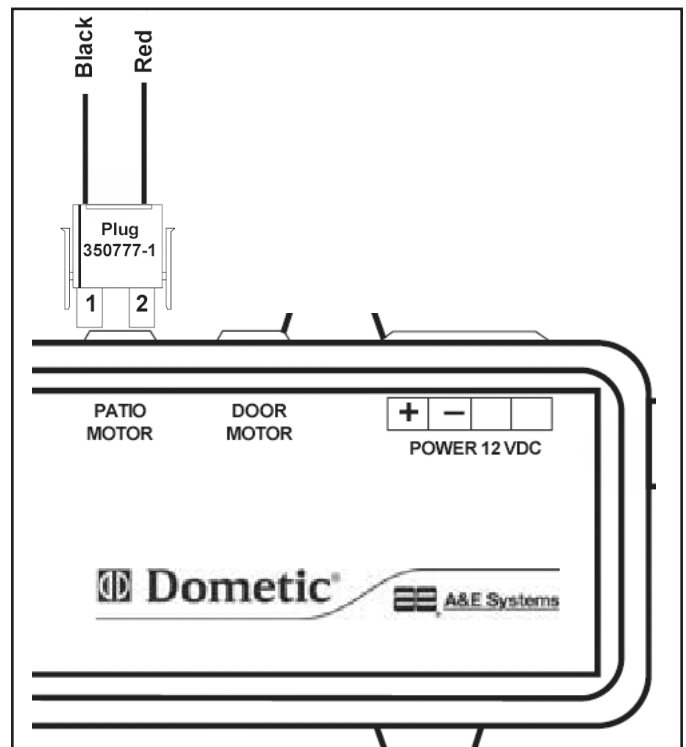

For further diagnostic assistance, please call:

**Dometic LLC**  
 Technical Service Dept.  
 509 South Poplar St.  
 LaGrange, IN 46761  
 (800) 216-5115