

NORCOLD



TROUBLE SHOOTING & VENTILATION GUIDE

For Marine and Truck DC/DE Refrigerators

NORCOLD, INC.
P.O BOX 4248
SIDNEY, OH 45365-4248

Part No. 620265
July 06, 1998

Troubleshooting

Symptoms:	
1. Does not cool - Compressor does not run on AC or DC	See Checks: 1 thru 6
2. Does not cool - Compressor runs on AC; not DC	See Checks: 1 thru 6
3. Does not cool - Compressor runs on DC; not AC	See Checks: 1 thru 6
4. Does not cool - Compressor runs continuously on AC or DC	See Checks: 5, 7 & 9
5. Insufficient cooling - Compressor runs continuously on AC or DC	See Checks: 5, 7 & 9
6. Insufficient cooling on AC - DC cooling O.K.	See Checks: 1 thru 6
7. Insufficient cooling on DC - AC cooling O.K.	See Checks: 1 thru 6
8. Insufficient cooling - Compressor slow or erratic	See Checks: 1, 2, 3, 5 & 7
9. Overcooling	See Check: 5 & 6
10. Excessive Frost	See Check: 8
11. Thermostat out of calibration or ineffective	See Checks: 5 & 6

NOTE: Perform all checks before replacing component parts.

Check # 1 - Input Voltage

Check to insure;

- 120 volts AC input voltage is properly connected and within 108 volts AC - 132 volts AC/60 Hz.
- 12 volts DC input voltage is properly connected (polarity not reversed) and within 10.5 volts DC - 15.4 volts DC.

NOTE: For the 12 volts DC input voltage, do not use a battery charger or a converter.

Check 2A - Power Supply Output to the Compressor

NOTE: Before performing check-out procedure, allow compressor temperature to stabilize and equal to room ambient temperature.

1. Remove wire from compressor as shown in Figure 1. Measure the Power Supply Output Voltage between Point A and Point B.

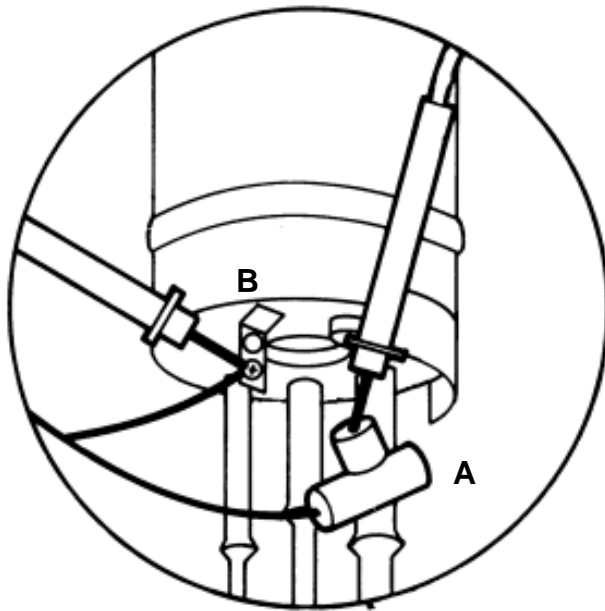

Figure 1

Power Supply Output Voltage Specification:

40 Watt Compressor:

AC & DC Operation 23-28 volts AC

60 Watt Compressor:

AC & DC Operation 24-31 volts AC

IMPORTANT:

With wire removed from the compressor and if the voltage reading is not as defined under the Power Supply Output Specifications, proceed to Power Supply Check Out Procedure (Check 4).

Check 2B - Power Supply Output to the Compressor

NOTE: Before performing check-out procedure, allow compressor temperature to stabilize and equal the room ambient temperature.

1. Turn the refrigerator ON.
2. With wire attached to the compressor, measure the AC output of the Power Supply to the compressor between Point A and Point B (Figure 1).

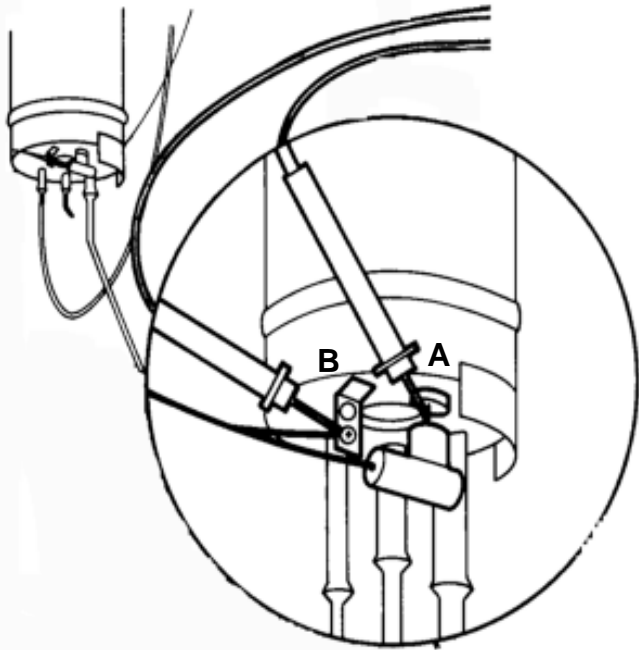

Figure 2

Power Supply Output Voltage Specifications:

40 Watt Compressor:

AC & DC Operation 18-23 volts AC, 1-2 Amps

60 Watt Compressor:

AC & DC Operation 23-26 volts AC, 1.9-2.5 Amps

IMPORTANT:

With wire attached and the voltage or Amp readings are higher or lower than defined under the Power Supply Output Specifications, replace the cooling unit.

For both 40 and 60 watt compressors, when the current draw exceeds 2.5 Amps, the compressor is locked (seized), replace cooling unit.

Check 3 - Compressor Winding Resistance

1. Turn the refrigerator to OFF.
2. Remove the black wire to the compressor as shown in both Figure 3 and Figure 4. Measure the resistance of the compressor between Point A and Point B.

0-2 Ω for both 40 and 60 watt = compressor coil shorted. Replace Cooling Unit.

2.0 - 2.3 Ω for 60 watt compressor = compressor O.K.

2.6 - 3.0 Ω for 40 watt compressor = compressor O.K.

$\infty \Omega$ = for both 40 and 60 watt = open compressor windings. Replace Cooling Unit.

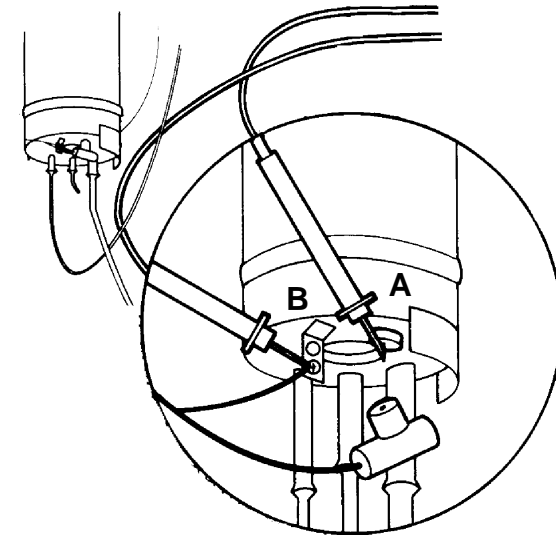

Figure 3

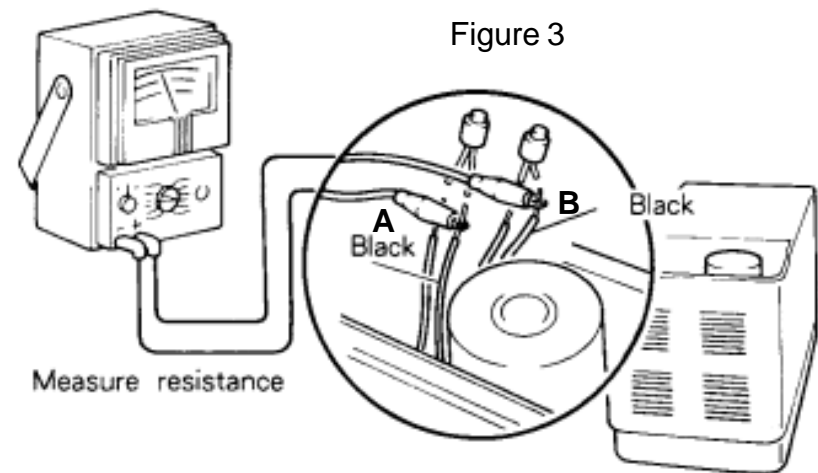

Figure 4

Note: The above resistance values were established at room ambient temperatures. Insure the the readings are taken after the motor windings have stablized at room temperatures before replacing the cooling unit.

Check 4 - Transformer Resistance

1. Turn both AC and DC power OFF.
2. Disconnect the transformer and remove from the circuit.
3. Measure transformer resistance.

0 Ω reading = shorted Transformer Windings . Replace Transformer.

∞ Ω reading = open Transformer windings. Replace Transformer.

Normal Transformer Windings Values

Unit Size	Primary Input			Secondary (Out)
	5 & 6 (PNK & TAN)	5 & 7 (PNK & TAN)	10 & 11 (ORG & WHT)	8 & 9 (BLU & BLU)
40 WATT	0.1 Ω	0.1 Ω	25 Ω	1.0 Ω
60 WATT	0.1 Ω	0.1 Ω	8-15 Ω	1.0 Ω

Test Points - Measuring Transformer Windings

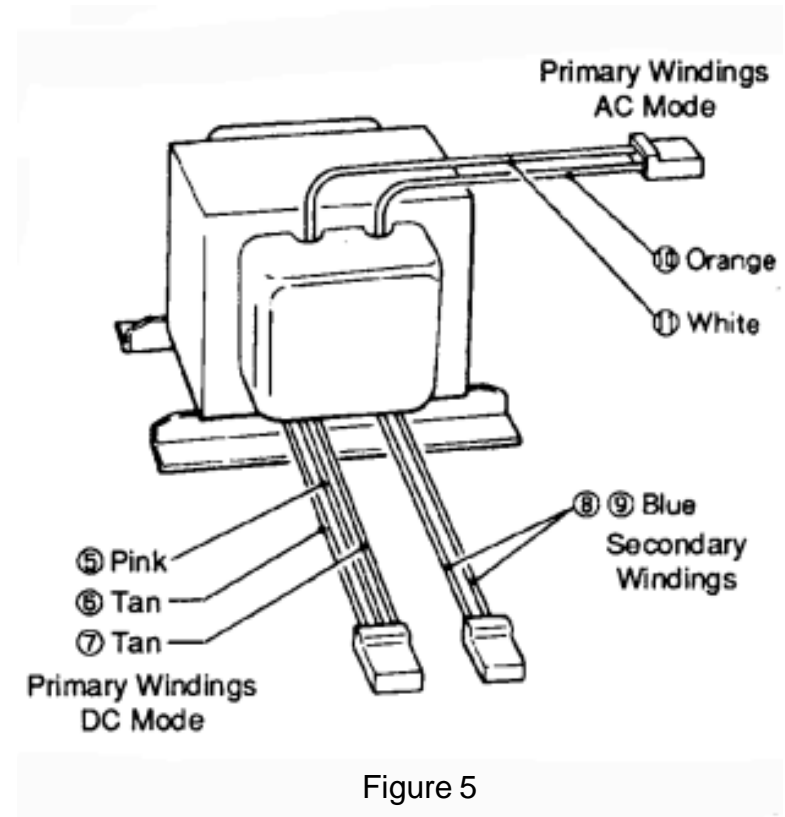

Figure 5

When the Transformer Winding values are normal, the Oscillator is defective and requires replacement.

NOTE: Before replacing the Oscillator, insure the Power Supply output voltages are correct and the input DC supply voltage is 12 volts DC while the refrigerator is operating.

Check 5A - Evaporator Thermistor

1. Turn the refrigerator to OFF and measure resistance of the Evaporator Thermistor as shown in Figures 6.

The Evaporator Thermistor is checked by measuring the temperature and resistance of the Thermistor.

Refer to the chart below and Figure 6.

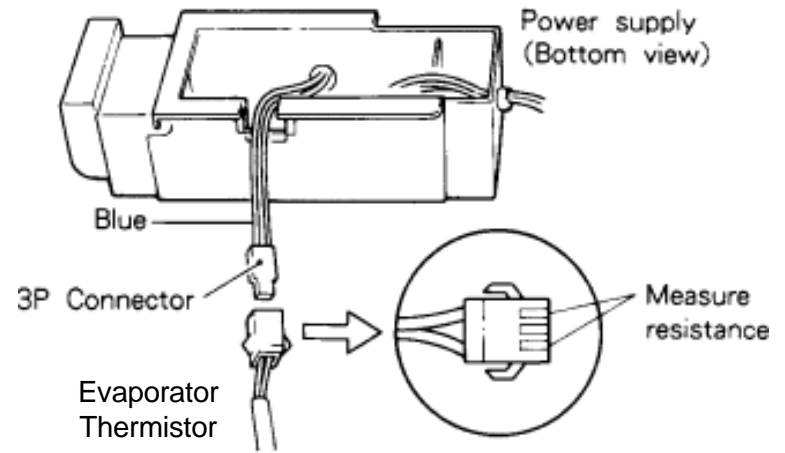

Figure 6 - Evaporator Thermistor

Evaporator Thermistor Resistance		
Thermistor Resistance °F	Resistance	Allowable Resistance Range
0	9.7K	28.7K - 10.7K
10	7.8K	7.0K - 8.6K
20	6.4K	5.7K - 7.0K
30	5.3K	4.8K - 5.7K
40	4.5K	4.0K - 4.9K
50	3.6K	3.2K - 4.0K
60	2.8K	2.5K - 3.1K
70	2.1K	1.9K - 2.3K
80	1.9K	1.7K - 2.0K
90	1.8K	1.6K - 1.9K

0 Ω = shorted thermistor. A shorted Thermistor will cause the compressor to run continuously . Replace Thermistor.

1.6K - 29K Ω for both thermistors = good Thermistor.

∞ Ω = open Thermistor windings. An open Thermistor will stop compressor operation. Replace Thermistor.

Check 5B - Condenser Thermister

1. Turn the refrigerator to OFF and measure the Condenser Thermistor as shown in Figures 7.

NOTE: Condenser Thermistor only functions on DC Operation.
Inspect all wire connections. The compressor will cease operating when there is an open connection in the Thermistor circuit.

Refer to chart below and Figure 7.

Condenser Thermistor Resistance		
Thermistor Resistance °F	Resistance	Allowable Resistance Range
40	26K	23K-29K
50	20K	18K-22K
60	15K	13.5K-16.5K
70	11K	10K-12K
80	10.5K	9K-11.5K
90	8K	7K-9K
100	7.5K	6.5K-8K
110	6.5K	6K-7K

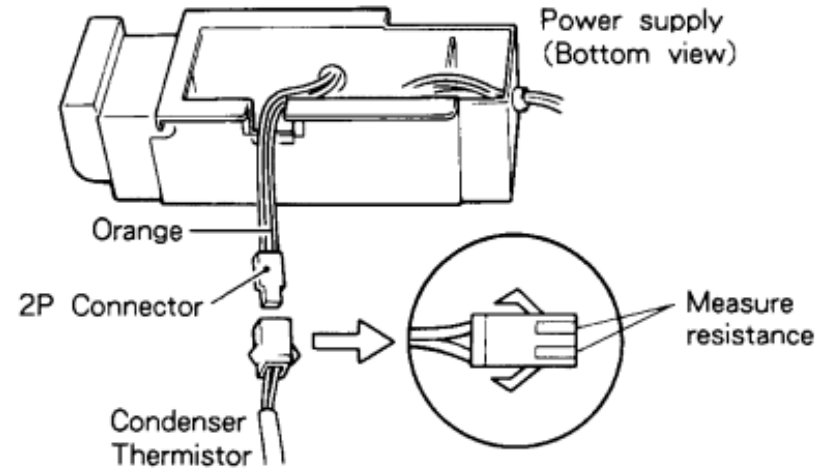

Figure 7 - Condenser Thermistor

0 Ω reading = shorted thermistor. A shorted Thermistor will cause erratic compressor operation. Replace Condenser Thermistor.

6K - 29K Ω reading = good Thermistor. (Refer to Chart)

∞ Ω reading = open Condenser Thermistor. An open Thermistor will stop compressor operation. Replace Thermistor.

Check 6 - Temperature Control Circuit

When 12 volt DC is applied to the refrigerator and the Temperature Control switch is **ON**, the LED lamp will illuminate (Figure 8).

With Temperature Control switch **ON** and the LED does not illuminate or the compressor does not run, remove the Temperature Control from the refrigerator without disconnecting wires.

Measure voltage between point 1 and point 2 (Figure 9).

Measurements of:

2 volts DC indicates Temperature Control is O.K.

0 volt DC indicates a defective Oscillator.

5 volts DC indicates a defective Temperature Control.

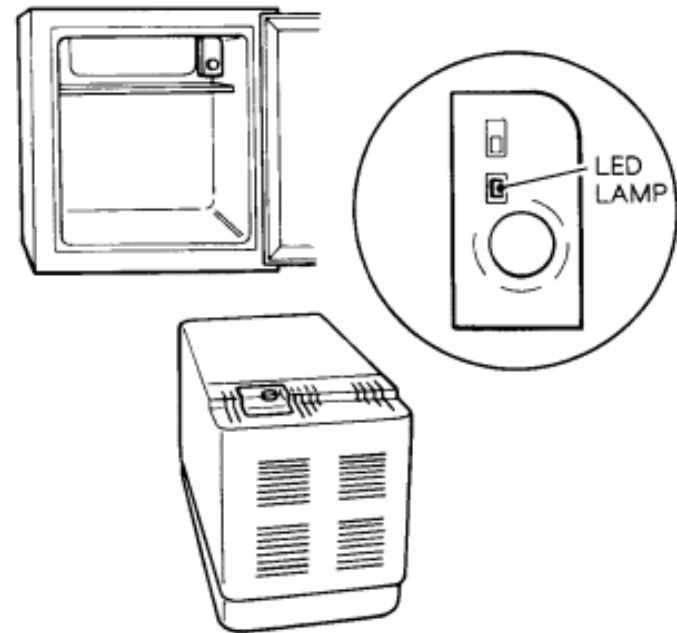

Figure 8

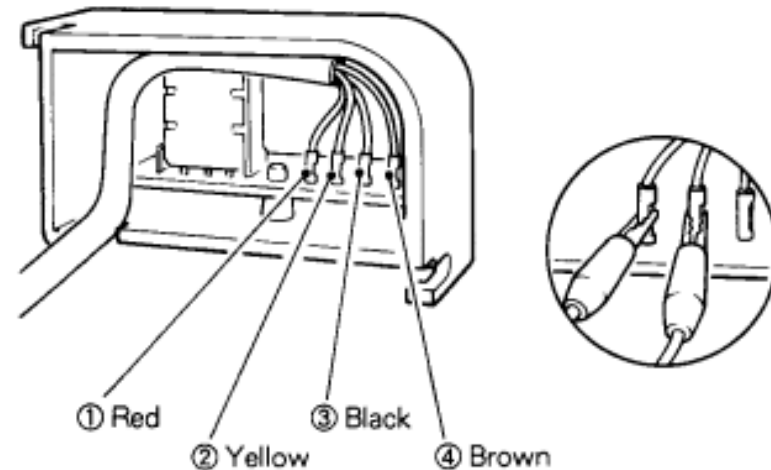

Figure 9

Check 7 - Visual Inspection

- Inspect cooling unit assembly for signs of damage.
- Inspect tubing and connections for refrigerant leaks (traces of oil).

Check 8 - Air Leaks

Door Seals (Figure 10)

Some frost inside the refrigerator is normal. When the door does not seal correctly, excessive frost will collect inside the refrigerator.

To check door seal:

- Close the door on a piece of paper that is the size of a dollar bill.
- Gently pull the paper. You should feel a slight drag between the door gasket and the refrigerator cabinet.
- Do this on all four sides of the door. If a slight drag is not observed adjust the door or door hinges.

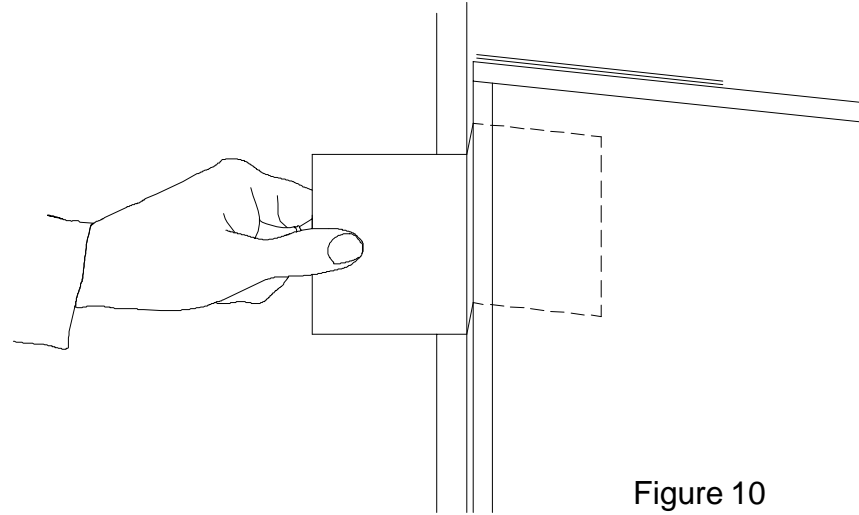

Figure 10

Check 9 - Ventilation

Ventilation is required to assure efficient operation of the refrigerator and to increase the life expectancy of the refrigerator's cooling system. Ventilation allows fresh air to come from and exhaust to the living area of the vehicle by means of an inlet and an exhaust vents. These vents allow an adequate airflow over the rear mounted refrigerator condenser and cooling unit. These vents must be unobstructed and provide an open path to the rear of the refrigerator.

Each refrigerator has a specified **minimum** air flow requirement. It is suggested to provide as much ventilation as possible. The more air circulating over the rear of the refrigerator, the more efficient the refrigerator will operate. Refer to Figures 11, 12 and 13 on page 10 and the Ventilation Requirement Chart on page 11.

Check 9 - Ventilation (continued)

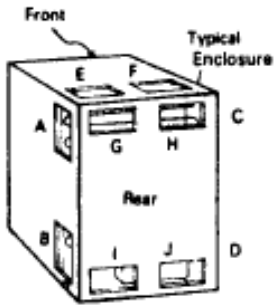
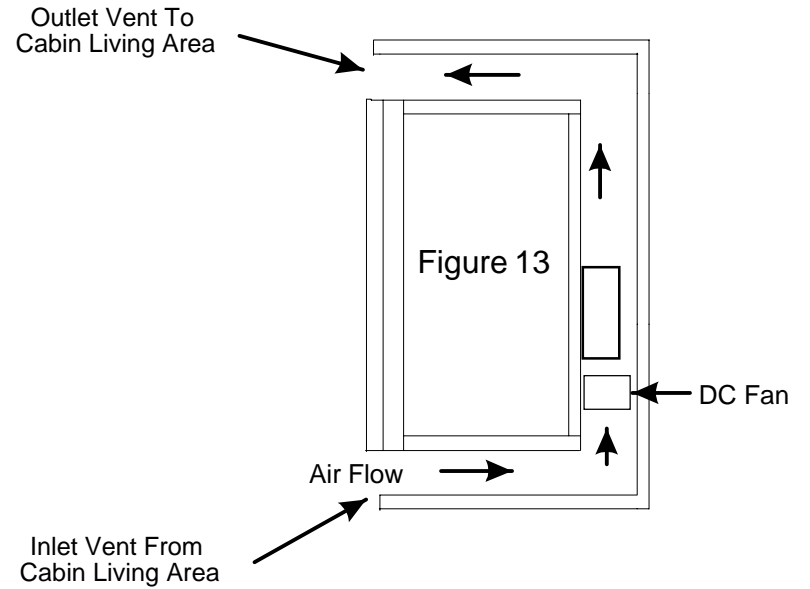
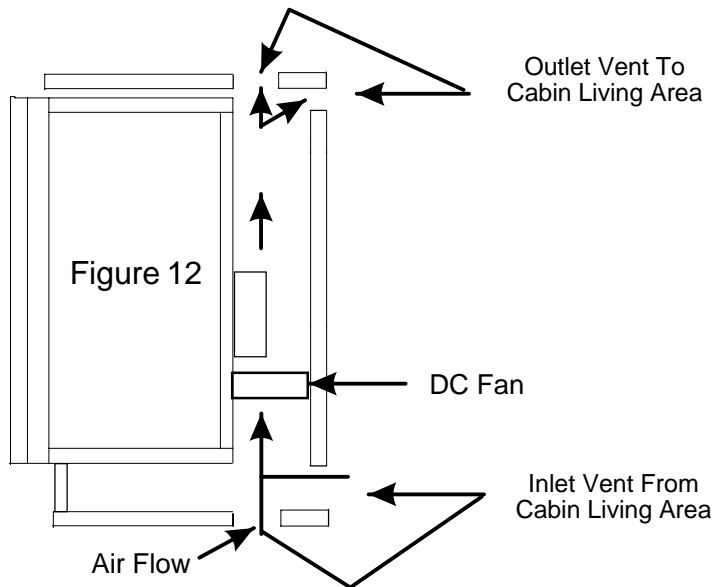

Figure 11

Figure 1: Approved venting arrangements - venting should be installed using any of the following cutout location combinations.

A/B	B/C	C/D	D/E	E/I	F/I	G/J	H/I
A/D	B/E	C/I	D/F	E/J			H/J
A/I	B/F	C/J	D/G				
A/J	B/G		D/H				
	B/H						



CAUTION

Failure to provide the required ventilation will result in shortened life expectancy of the cooling unit, poor refrigeration, continuous operation, accelerated battery discharge and will void the refrigerator warranty.

In addition to the required vents sizes, a fan can be added to increase the refrigerator performance and to decrease the refrigerator current consumption. A fan kit is available through Norcold part distribution network. Refer to Fan Kit Assembly chart on page 12.

Check 9 - Ventilation (continued)

VENTILATION REQUIREMENT CHART			
Refrigerator Model	Min. Vent Sizes Without Fan	Min. Vent Sizes With Fan	Recommended Fan CFM
DC340D,F,K	50 Square Inches Inlet 50 Square Inches Outlet	25 Square Inches Inlet 25 Square Inches Outlet	28
DC351D	50 Square Inches Inlet 50 Square Inches Outlet	25 Square Inches Inlet 25 Square Inches Outlet	28
DE351D	50 Square Inches Inlet 50 Square Inches Outlet	25 Square Inches Inlet 25 Square Inches Outlet	28
DE350D	50 Square Inches Inlet 50 Square Inches Outlet	25 Square Inches Inlet 25 Square Inches Outlet	28
DC390D,V	100 Square Inches Inlet 100 Square Inches Outlet	35 Square Inches Inlet 35 Square Inches Outlet	28
DE390D	100 Square Inches Inlet 100 Square Inches Outlet	35 Square Inches Inlet 35 Square Inches Outlet	28
DE/EV541	100 Square Inches Inlet 100 Square Inches Outlet	50 Square Inches Inlet 50 Square Inches Outlet	28
DE/EV561	100 Square Inches Inlet 100 Square Inches Outlet	50 Square Inches Inlet 50 Square Inches Outlet	60

FAN KIT ASSEMBLY			
Part Number	Description	Model	AMP
16092490009	Fan Kit	DE351D	.15
16092493007	Fan Kit	DC351D	.15
16092493008	Fan Kit	DC340D/DC340K	.15
16092850009	Fan Kit	DE561	.1
16092496009	Fan Kit	DE541	.15
16092497009	Fan Kit	DE390D	.15

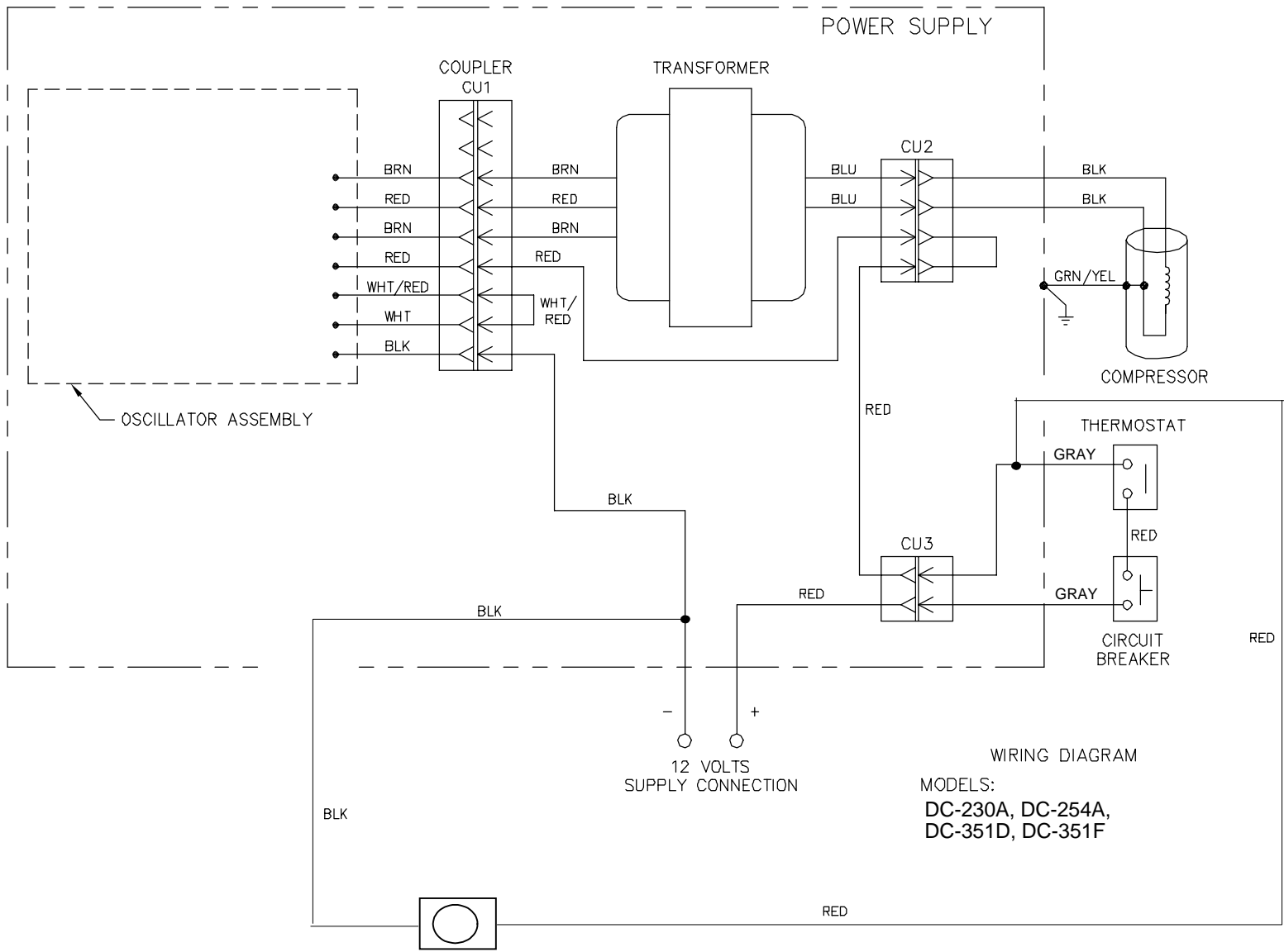

DC FAN
 DC-351D (Fan Optional - Fan Kit Available)
 DC-351F (Fan Standard Equipment)

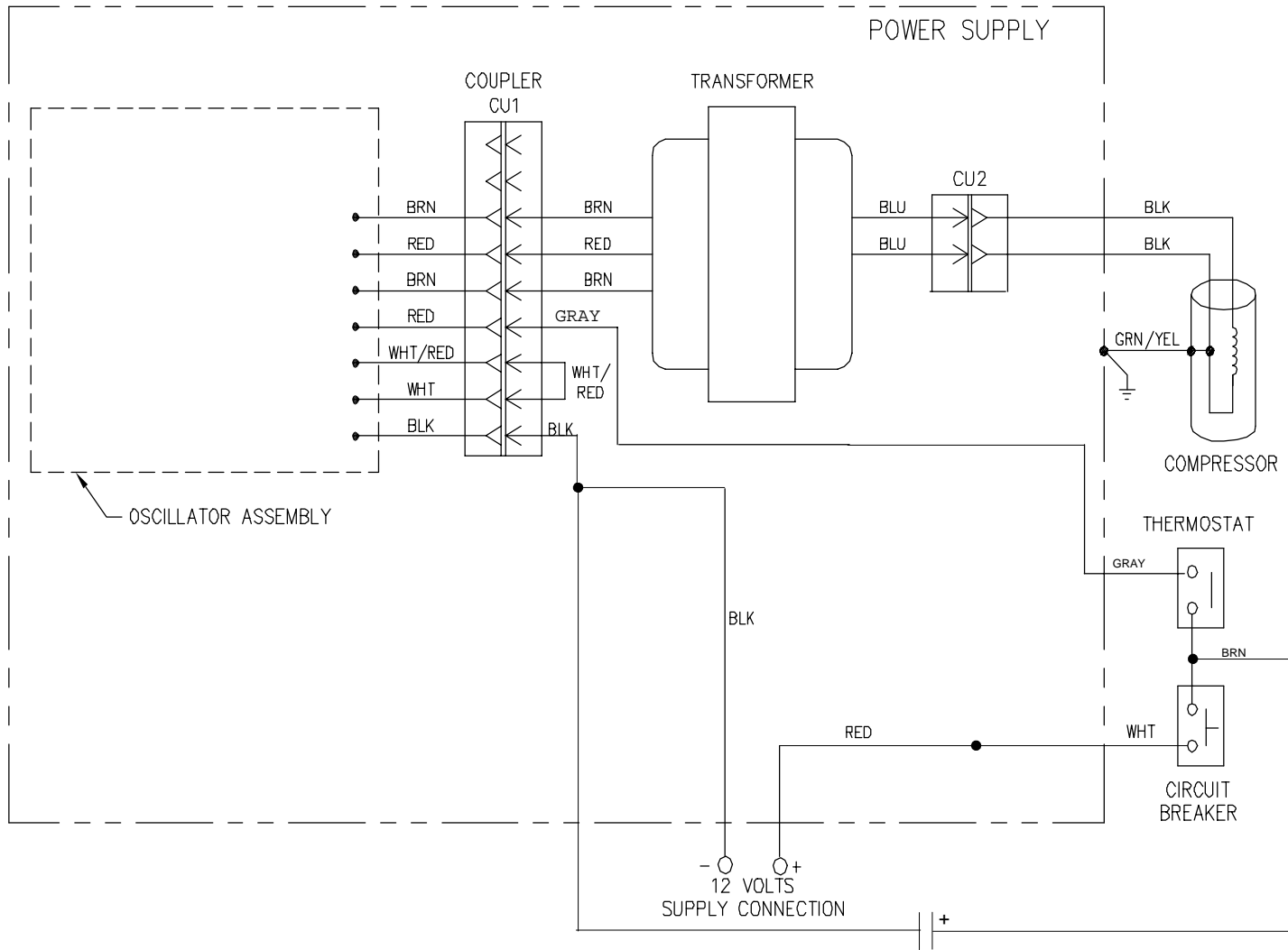

Wiring Diagram
DC340K

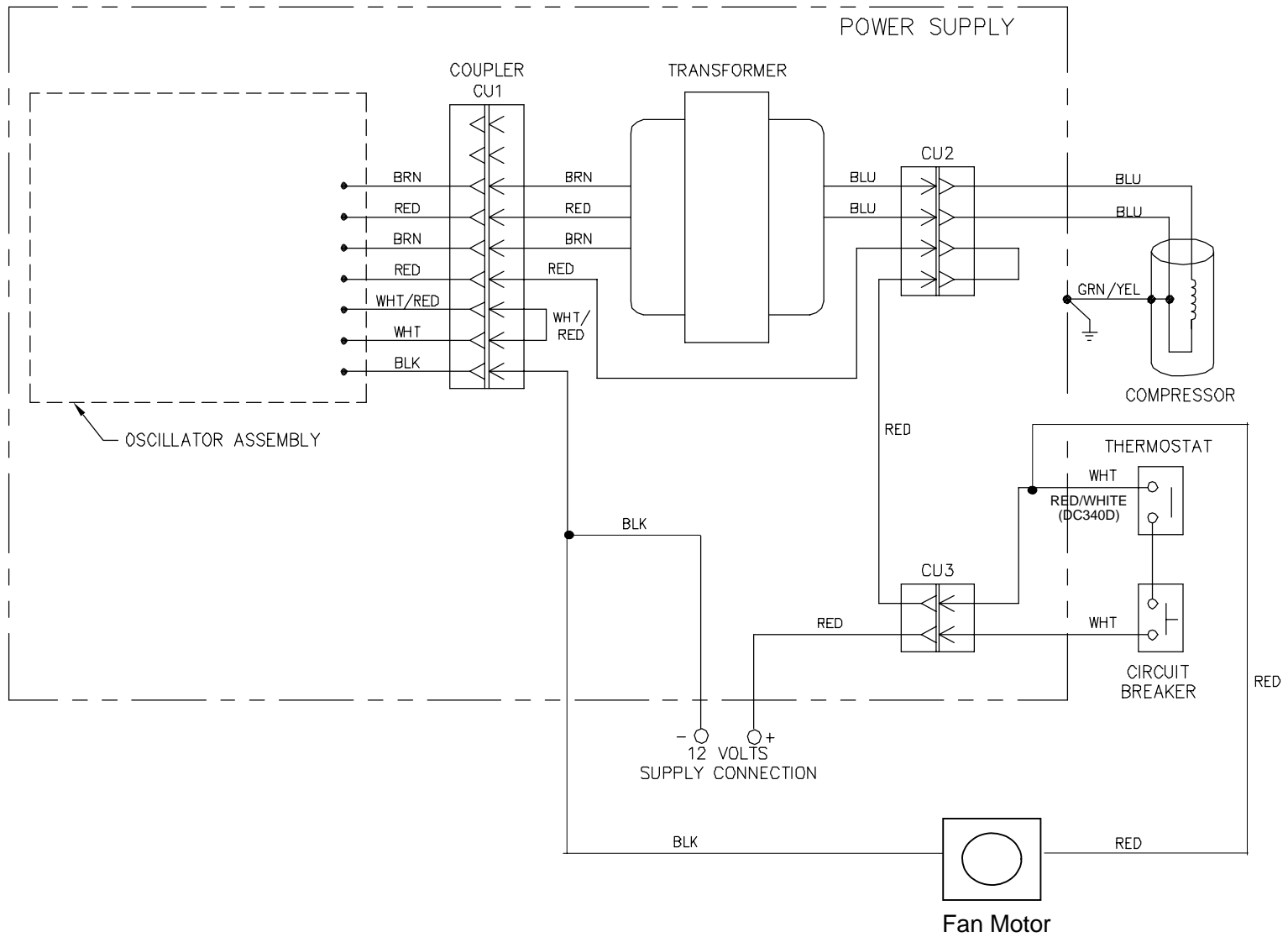

Wiring Diagram
 DC340D (Fan Optional - Kit Available)
 DC340F (Fan Standard Equipment)

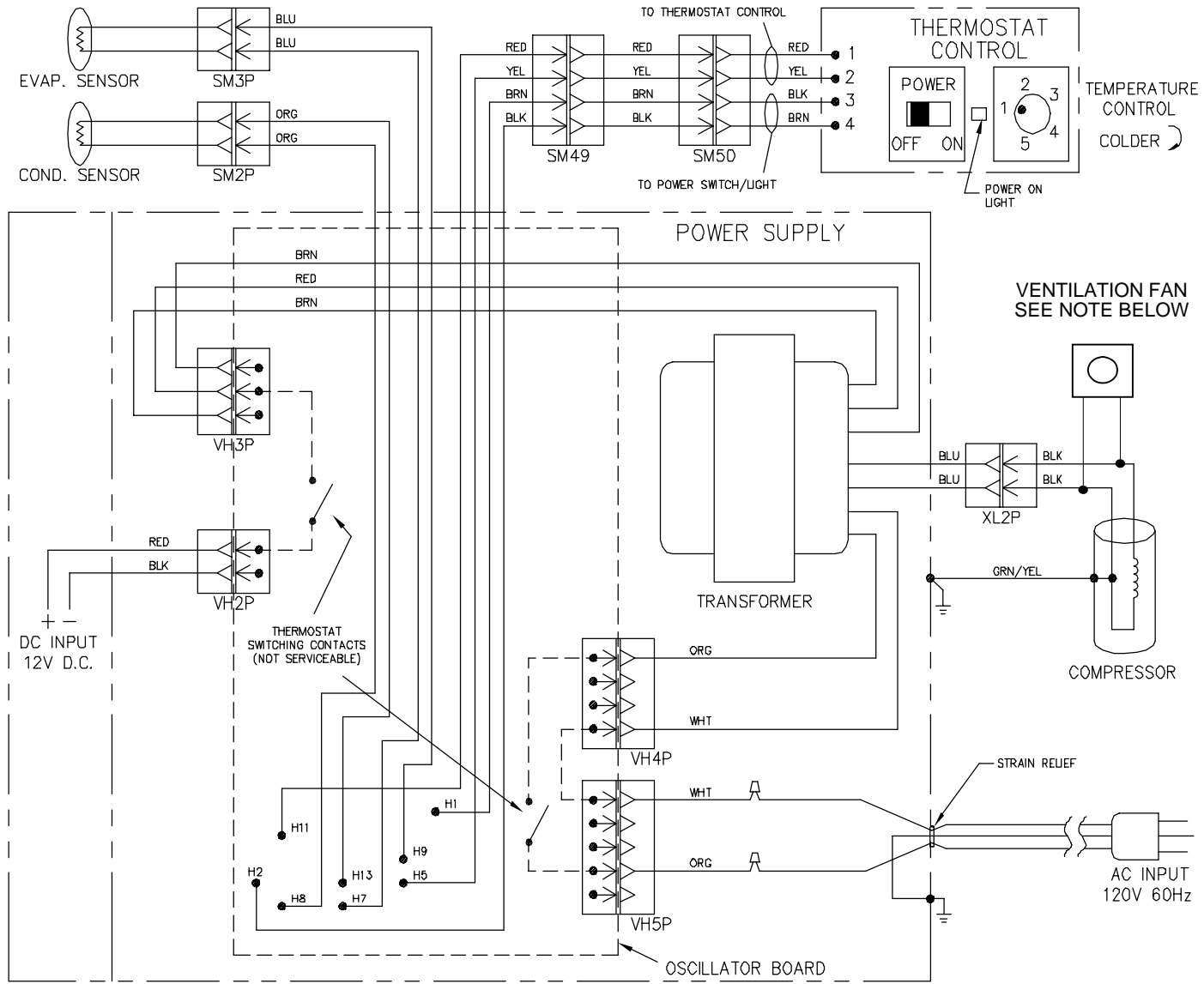

DRAWING NO.: C-16975C

**WIRING DIAGRAM
MODELS:**

DE250G, DE251E, DE400D, DE540, DE560, DE350D,
 NOTE: DE351D (Fan Optional - Kit Available) DE351F (Fan Standard Equipment)
 DE390D (Fan Optional - Kit Available) DE390F (Fan Standard Equipment)
 DE541F & DE561F (Fan Standard Equipment)

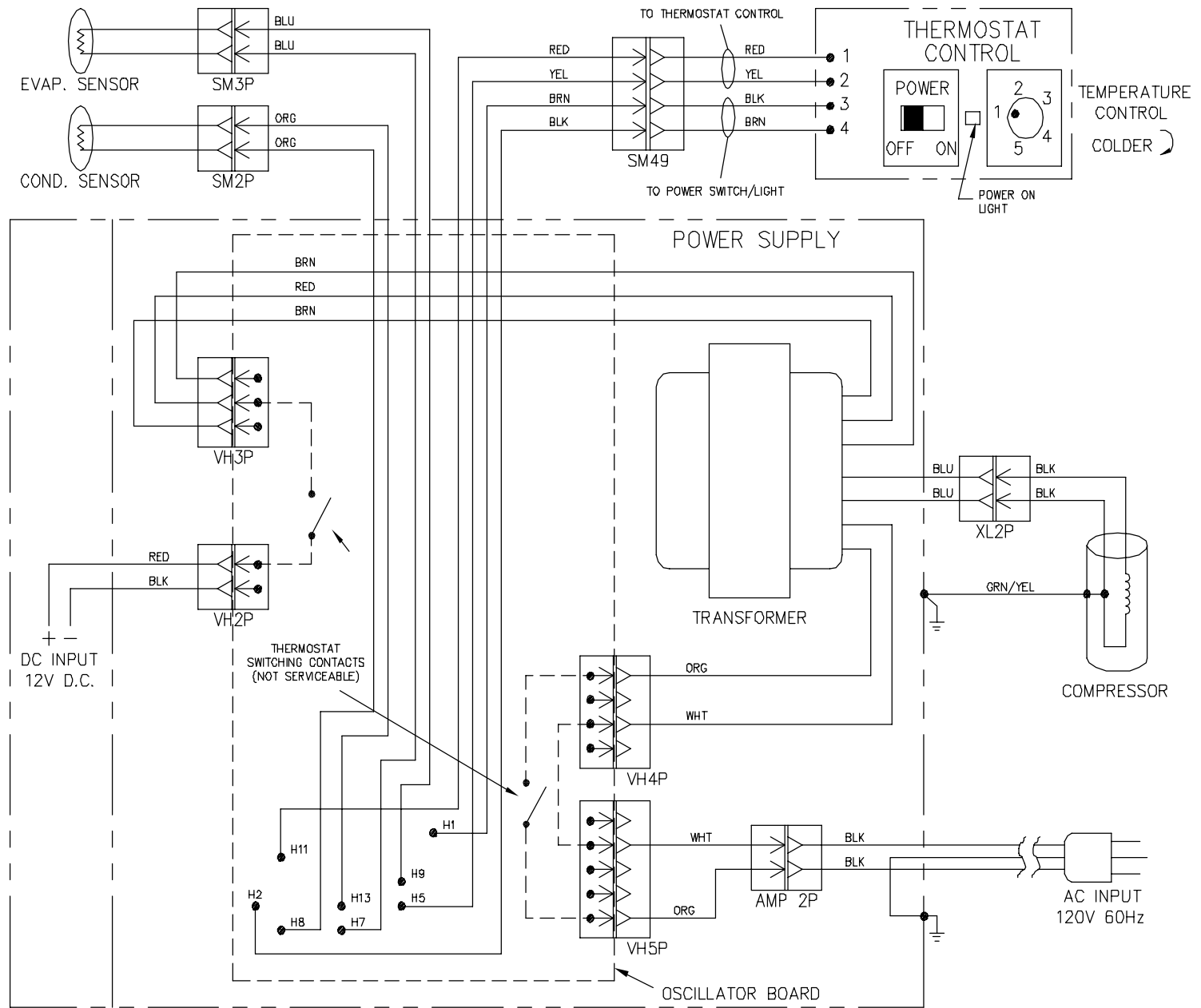

DRAWING NO. C-16296C

WIRING DIAGRAM DE-704D

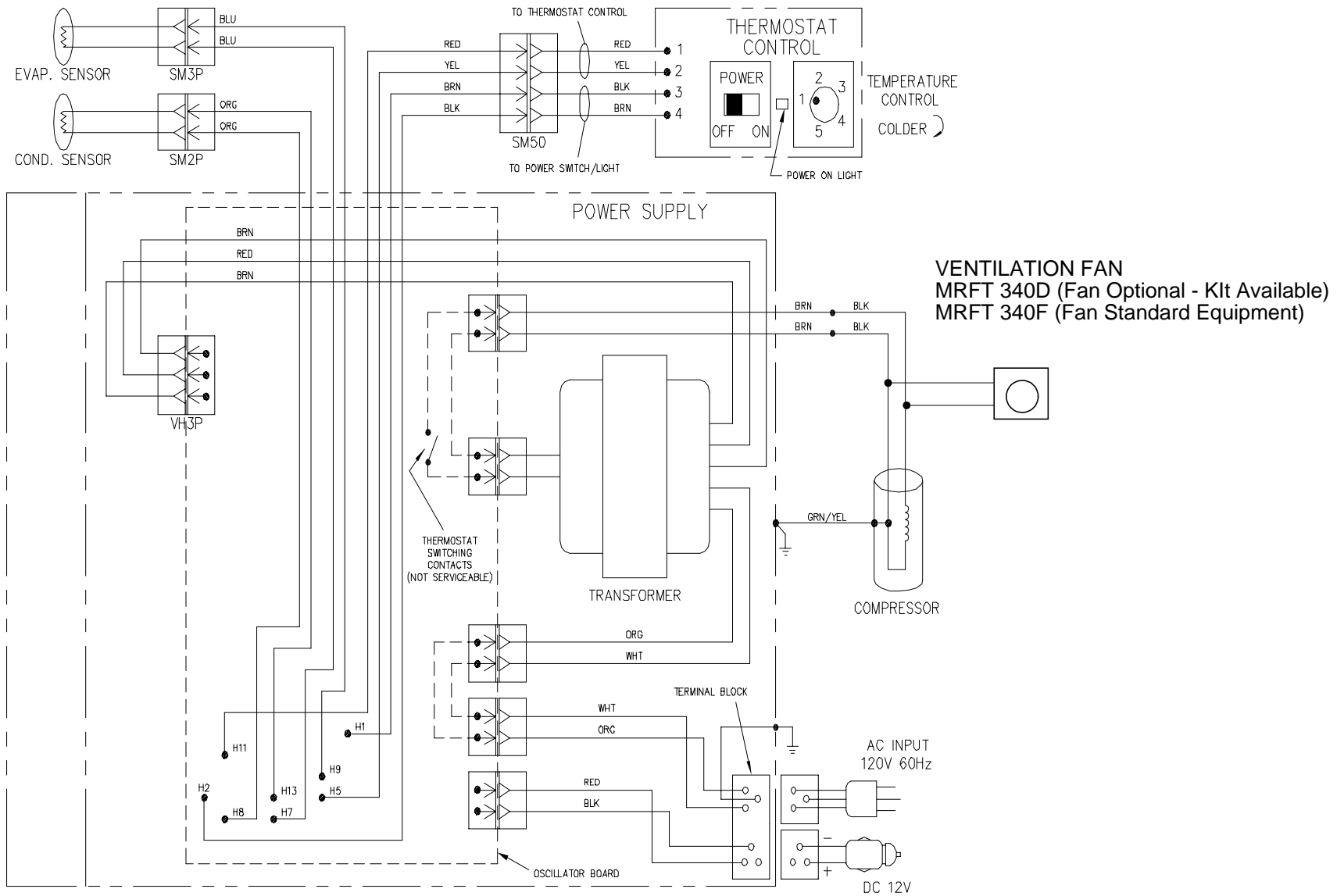

DRAWING NO.: C-17469C

WIRING DIAGRAM - MRFT MODELS; 315D, 330D, 340D, 340F, 615C, 630C, & 640C

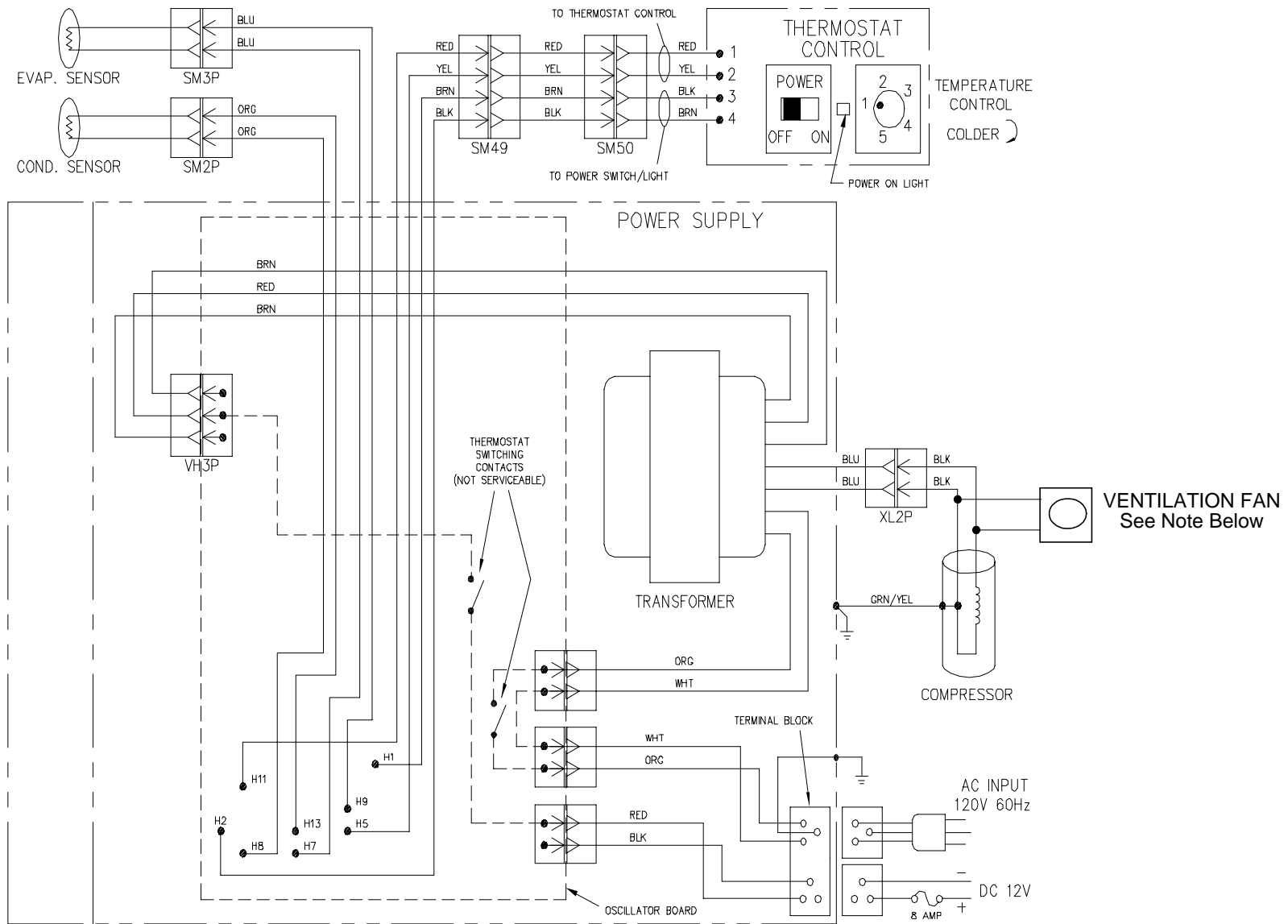

DRAWING NO.: C-17470A

WIRING DIAGRAM MRFT660A, MRFT360D & MRFT360F
NOTE: MRFT360F (Fan Standard Equipment)
MRFT360D (Fan Option Not Available)