



Service Manual

Gas/Electric Refrigerators

MODELS

N61X/N81X

N62X/N82X

N64X/N84X

N64XIM/N84XIM

N64X.3/N84X.3

WARNING

DO NOT install this refrigerator in below deck marine applications. Do not install this refrigerator in fixed indoor cabin or other dwelling applications. This refrigerator must use only NORCOLD designed and approved outside air intake and exhaust ventilation for correct and safe operation. Any other ventilation could cause lethal combustion exhaust fumes and or/explosive propane gas fumes to be in the living area and/or below deck.

Introduction	1	Orifice.....	29
About this Manual	1	Burner	29
Model Identification.....	1	Burner Tube	29
Information Label.....	1	Flue.....	30
Cooling Unit Serial Number	1	Heat Deflector.....	30
Certification and Code Requirements.....	1	Flue Baffle.....	30
About Installation	1	Flame Appearance.....	30
Replacement Parts	1	Burner Cleaning Procedure	31
Technical Assistance.....	1		
Safety Awareness	3	Electrical Requirements and Components	33
Safety Notice	3	DC Voltage Requirements and Polarity	33
Attention Statements	3	Power Board DC Fuse	33
Safety Statements	3	DC Power Wiring Requirements.....	33
		2-Way Models	33
Specifications	4	3-Way Models	33
N61X/N81X Models	4	AC/DC Converter as Power Source	33
N62X/N82X Models	5	DC Heater–3-Way Refrigerators Only	33
N64X/N64X.3/N84X/N84X.3 Models	6	DC Heater Circuit Fuse.....	33
		Lamp Assembly.....	34
Troubleshooting – Quick Reference Guide	7	Divider Heater	34
N61X/N81X Displayed Fault Codes	8	AC Heater	34
N62X/N82X Displayed Fault Codes	9	AC Power Requirements	34
N64X/N84X Displayed Fault Codes	10	AC Heater Fuse	34
		AC Power Cord	35
Troubleshooting Flowcharts	11	Power Cord for Ice Maker Units.....	35
Blank Display – Refrigerator does not turn on.....	11	12 Vdc Ventilation Fan.....	35
F/no FL Fault Code – Burner failed to ignite or reignite.....	12		
S/Sr Fault Code – Flame sense circuit failure	13	Cooling Unit	37
dc LO Fault Code – Low DC voltage	13	Description.....	37
dc HI Fault Code – DC voltage high	14	Heat Absorption	37
dc rE Fault Code – DC relay stuck closed	14	Leveled Operation	37
dc HE Fault Code – DC heater failed open	15	Gradual Decrease in Cooling Efficiency	37
A/no AC Fault Code – No AC power available.....	16	Cooling System Monitoring.....	37
r/AC rE Fault Code – AC relay stuck closed.....	16	First “No Cooling” Fault Occurrence	37
AC HI Fault Code – AC voltage high	17	Two Recorded “No Cooling” Fault Occurrences	37
AC LO Fault Code – AC voltage low.....	17	Troubleshooting Cooling Faults	38
H/AC HE Fault Code – AC heater failed open	18	Poor or No Cooling on AC Mode.....	38
Food Compartment Lamp Switch	19	Poor or No Cooling on LP Gas Mode	38
Lamp Switch Operation.....	19	Poor or No Cooling on DC Mode – 3-Way Models	38
d/dr Fault Code – Door open for more than 2 minutes	19	Refrigerant Leakage	38
Lamp Switch Testing Procedure	19	Disposal of Cooling Unit	38
Thermistor Failure Fault – Controls in backup operating	20	Cooling System Diagnostic Flowchart	39
system mode	20	Replacing the Cooling Unit	41
Backup Operating System (BOS).....	20	Removing the Refrigerator from the Enclosure.....	41
N61X/N81X Backup Operation	20	Removal of Cooling Unit.....	42
N62X/N82X/N64X/N84X Backup Operation	20	Installation of Replacement Cooling Unit.....	42
Power Board Resetting Procedure	21	Reinstallation of Refrigerator into Enclosure.....	44
n/no co Fault Code – No cooling detected by the controls ..	21		
		Electronic Components	45
Ventilation	22	Power Board	45
Roof Exhaust Venting	22	Removal–Power Board	45
Air Intake Vent	22	Installation–Power Board.....	46
Roof Exhaust Vent	22	Optical Control Assembly.....	46
Baffles.....	23	N61X/N81X Wiring Schematic.....	47
Vertical Angled Baffles	23	N61X/N81X Wiring Pictorial.....	47
Double Sidewall Venting.....	24	N62X/N82X/N64X/N84X/N64X.3/N84X.3 Wiring Pictorial	48
Air Intake Vent.....	24	– Units with serial number 851759 and higher	48
Sidewall Exhaust Vent	24	N62X/N82X/N64X/N84X/N64X.3/N84X.3 Wiring Schematic	48
		– Units with serial number 851759 and higher	48
LP Gas System	27	N62X/N82X/N64X/N84X/N64X.3/N84X.3 Wiring Pictorial	49
Pressure Requirements.....	27	– Units with serial number lower than 851759.....	49
Testing for LP Gas Leaks.....	27	N62X/N82X/N64X/N84X/N64X.3/N84X.3 Wiring Schematic	50
Components	28	– Units with serial number lower than 851759.....	50
Solenoid Gas Valves.....	28		
New Style Solenoid Gas Valve	28	Controls	51
Old Style Solenoid Gas Valve	28	N61X/N81X Optical Control Assembly.....	51
Solenoid Gas Valve Connections.....	28	Front Box	51
		Removal and Installation of Optical Control Assembly.....	51
		Modes of Operation	52

AUTO Mode	52	Low Ice Yield.....	69
No AC Power	52	Water Valve Operation Test	69
AC Power Restored	52	Water Valve Solenoid Resistance.....	69
No AC and No Flame	52	Mold Heater Resistance Check	70
GAS Mode	52	Checking Voltage at Motor Terminals	70
No Flame	52	Winterizing the Ice Maker Water.....	70
Backup Operating System	52	N64X IM/N84XIM – Wiring Pictorial for Ice Maker Wired to Refrigerator AC Cord	70
“Gas Lock-Out”	52	N64X IM/N84XIM – Wiring Schematic for Ice Maker Wired to Refrigerator AC Cord	70
N62X/N82X Optical Control Assembly.....	53	N64X IM/N84XIM – Wiring Schematic for Ice Maker Wired to White AC Power Cord.....	72
Front Box	53	N64X IM/N84XIM – Wiring Pictorial for Ice Maker Wired to White AC Power Cord.....	72
Removal and Installation of Optical Control Assembly	53		
Modes of Operation	54		
AUTO Mode	54		
AUTO AC Operation	54		
AUTO LP Gas Operation	54		
Shift from AUTO LP GAS to AUTO AC	54		
No AC Power and No Flame.....	54		
Troubleshooting a “F”/”no” “FL” and “A”/”no” “AC” Faults	54		
AC-Manual Mode	54		
LP Gas–Manual Mode	54		
No AC Power or Loss of AC Power.....	55		
Troubleshooting a “A”/”no” “AC” Fault	55		
AC Power Restored	55		
Flame Fails to Ignite or Flame Goes Out.....	55		
Clearing “Gas Lock-Out”	55		
Troubleshooting a “F”/”no” “FL” Fault.....	55		
N64X/N84X Optical Control Assembly.....	56		
Front Box	56		
Removal and Installation of Optical Control Assembly	56		
Modes of Operation	57		
AUTO	57		
AUTO AC Operation	57		
AUTO LP Operation	57		
Shift from AUTO LP GAS to AUTO AC	57		
No AC Power and No Flame.....	57		
Shift from AUTO LP GAS to AUTO AC	57		
Troubleshooting No Flame and No AC Faults	57		
AUTO DC Operation – 3-Way Units Only	58		
AC-Manual Mode.....	58		
No AC Power or Loss of AC Power.....	58		
AC Power Restored	58		
Troubleshooting “no” “AC” Fault	58		
LP-Manual Mode	59		
Flame Fails to Ignite or Flame Goes Out.....	59		
DC-Manual Mode.....	59		
No DC Power to DC Heater Circuit.....	59		
Diagnostic Mode — Models N62X/N82X-----	60		
Diagnostic Mode	60		
Accessing the Diagnostic Mode.....	60		
Changing Screens	60		
Exiting the Diagnostic Mode	60		
Screens and Diagnostic Segments Information.....	61		
Diagnostic Mode — Models N64X/N84X-----	63		
Diagnostic Mode	63		
Accessing the Diagnostic Mode.....	63		
Changing Screens	63		
Exiting the Diagnostic Mode	63		
Screens and Diagnostic Segments Information.....	64		
Ice Maker-----	66		
Wire Harness	66		
Fill Tube	66		
Water Valve.....	66		
Specifications.....	66		
Replacing the Ice maker	67		
Ice Maker Troubleshooting Chart.....	67		
Cycle Test	68		
Water Fill Adjustment.....	69		

About this Manual

This service manual provides maintenance, diagnostic, and repair information for **NORCOLD**® models N6XX and N8XX (N6XX/N8XX) gas absorption refrigerators. It is a reference tool designed for technicians who are knowledgeable in the theory and operation of gas/electric absorption refrigerators, liquefied petroleum (LP) gas-propane-systems, and AC/DC electrical systems as installed in a variety of recreational vehicles (RV).

All information, illustrations, and specifications contained in this publication are based on the latest product information available at the time of publication. **NORCOLD**® reserves the right to make changes at any time without notice.

Model Identification

Models N61X, N81X, N62X, N82X, N64X, and N84X are 2-way refrigerators that operate on AC power or LP gas.

Models N64X.3 and N84X.3 are 3-way refrigerators, that operate on AC power, LP gas, or DC power.

Letter(s) appended to the model number identify factory installed accessories. For example, an N821F is a 2-way refrigerator equipped with a factory installed 12 Vdc cooling unit ventilation fan; an N641IM is a 2-way refrigerator equipped with an ice maker.

Information Label

The information label is located in the upper right corner of the fresh food compartment just below the divider. See Figure 1, page 2. The label provides the following information:

- Serial number.
- Model number.
- LP gas (propane) pressure.
- Btu/h.
- AC voltage and amperage.
- DC voltage and amperage.
- Design certification.
- Vent kit requirement.

Cooling Unit Serial Number

The cooling unit serial number appears on the cooling unit bar code label. The label is affixed to the surface of the cooling unit leveling chamber. See Figure 2, page 2.

Certification and Code Requirements

NORCOLD® N6XX/N8XX gas/electric absorption refrigerators are certified under the latest edition of *ANSI Z21.19B* standards for installation in mobile homes or recreational vehicles, and with the Canadian Standards Association *CAN/CGA-1.4-M94*.

Electrical components are  compliant.

About Installation

Refrigerator installation must conform with the *N6XX/N8XX Installation Manual* for the **NORCOLD**® limited warranty to be in effect. Installation must also comply with applicable local codes and standards set by the cognizant certification agency.

Replacement Parts

Use only authorized **NORCOLD**® replacement parts. Generic parts do not meet **NORCOLD**® specifications for safety, reliability, and performance. The use of unauthorized aftermarket or generic replacement parts voids the refrigerator's limited warranty coverage.

Technical Assistance

If unable to resolve technical issues using the information provided in this manual, technical support is available through **NORCOLD**® Customer Service Center:

-  Telephone:1-800-444-7210.
-  Fax:1-937-497-3183.
-  World Wide Web: www.norcold.com.

The following information is required to process technical support requests:

- Model number.
- Serial number.
- Make, model, and year of recreational vehicle.



Figure 1. Refrigerator Information Label Location.



Figure 2. Cooling Unit Bar Code Label Location.

Safety Notice

It is not possible to anticipate all of the conceivable ways or conditions under which the refrigerator may be serviced or to provide cautions as to all of the possible hazards that may result. Standard and accepted safety precautions and equipment should be used when working on electrical circuits and handling toxic or flammable materials. Safety goggles and other required protection should be used during any process that can cause material removal, such as when removing a leaking cooling unit and cleaning components.

Attention Statements

The safety alert symbol  followed by the word **WARNING** or **CAUTION** identifies potential safety hazards or conditions.

The safety alert symbol with the appropriate heading appear

on all safety labels posted on the refrigerator and safety awareness notices presented throughout this manual.



WARNING:

The above heading identifies hazards or conditions, which if ignored can cause serious injury, death, and/or extensive property damage.



CAUTION:

The above heading identifies hazards, which if ignored can cause injury and/or property damage.

Safety Statements

- ▲ **Do not** modify, alter, or equip the refrigerator to the use of any other fuel (natural gas, butane, etc.). N6XX/N8XX refrigerators are designed and equipped for the use of LP gas—*propane gas*—only.
- ▲ Incorrect installation, adjustment, alteration, or maintenance of the refrigerator can cause personal injury, property damage, or both.
- ▲ **Do not** smoke, light fires, or create sparks when working on the propane gas system.
- ▲ **Do not** use an open flame for leak testing any of the propane gas system components. Propane gas is highly flammable and explosive.
- ▲ Always use two wrenches to tighten or loosen LP gas connections. Damaged connections, piping, and components create the potential for gas leaks.
- ▲ All electrical connections and repairs to the refrigerator must comply with all applicable codes. Refer to the certification and code requirements section of the *N6XX/N8XX Installation Manual*.
- ▲ **Do not** work on live electrical circuits. Turn off AC power and DC power sources before attempting to remove, service, or repair any of the refrigerator's electrical or electronic components.
- ▲ **Do not** modify, bypass, or eliminate any of the refrigerator's electrical components, electronic circuits, or propane gas system components.
- ▲ **Do not** wet or spray liquids on or near electrical connections or electronic components. Most liquids, including leak detection solutions, are electrically conductive and pose the potential for an electric shock hazard, short electrical components, damage electronic circuits, and/or ignite a fire.
- ▲ **Do not** use leak test solutions that contain ammonia or chlorine. Ammonia and chlorine degrade copper and brass components.
- ▲ **The cooling unit is a sealed system under pressure!** **Do not** try to repair or recharge the cooling unit. **Do not** bend, drop, weld, drill, puncture, saw, or strike the cooling unit.
- ▲ **Handle a leaking cooling unit with extreme caution!** The cooling unit contains ammonia, hydrogen, and sodium chromate. Ammonia can cause severe skin and eye burns. Hydrogen is highly flammable, can ignite and burns with an intense flame. Certain chromium compounds, such as sodium chromate, are carcinogenic.
- ▲ **Do not** use extension cords. **Do not** remove the grounding prong from the refrigerator AC power cord. **Do not** use a two prong adapter to connect the refrigerator to the AC outlet.
- ▲ **Do not** over-fuse electrical circuits. Use specified fuses and AWG wire sizes. The specification section of this manual provides fuse size information. Refer to the *N6XX/8XX Installation Manual* for the correct AWG wire size specifications.
- ▲ **Prevent child entrapment!** Before disposing of the refrigerator, remove all doors and fasten all shelves with retainers.
- ▲ Some of the refrigerator's metal components have sharp corners and edges. Wear hand protection, such as cut resistant gloves, and exercise extreme care when handling the refrigerator.
- ▲ Make sure all hardware such as hinges and fasteners (retaining screws, etc.), are properly fastened.

SPECIFICATIONS

N61X/N81X Models

Storage volume

N61X	6.3 ft ³
N81X	7.5 ft ³

Rough opening dimensions (H x W x D)

N61X	52 7/8 in. x 23 1/2 in. x 24 in.
N81X	59 7/8 in. x 23 1/2 in. x 24 in.

Decorative panels dimensions

Thickness	3/16 in.
Freezer door (H x W, both models)	14 17/32 in. x 21 19/32 in.
Fresh food compartment (H x W)	
N61X	31 5/8 in. x 21 19/32 in.
N81X	38 5/8 in. x 21 19/32 in.

Controls

Type	Electronic with built-in diagnostics
Mode selector switch	3-position slide type
Temperature switch	5-position slide type
Temperature settings	1=cold, 5=coldest
Temperature sensor	Thermistor, fin mounted (10 th fin)

Off-level operating limits

Side-to-side	3 degrees-maximum
Front-to-back	6 degrees-maximum

DC power

Controls operating voltage	10.5 to 15.4 Vdc
Fuse, control circuit (F1 in power board)	5 A (tan color), automotive blade type
Fuse, fan (N6XXF/N8XXF models with an in-line fuse)	1A, 1/4 in. x 1 1/4 in. AGC type fast-acting

DC amperage draws (at nominal 12 Vdc)

Automatic ignition	0.50 A
Divider heater	0.25 A
Fresh food compartment lamp	0.46 A
Gas valve	0.146 A
Fan (N6XX/FN8XXF models only)	0.36 A

AC power

AC heater operating voltage	108 to 132 Vac
Fuse, AC heater circuit (F2 in power board)	8 A, 1/4 in. x 1 1/4 in. AGC type fast acting
AC heater rating	300 W (2.5 A @ 120 Vac) with resistance of 48Ω

LP gas (propane)

Operating pressure	10.5 to 11.5 in. w.c.
Heat output	1500 Btu/h @ 11 in. w.c.
Orifice	LP16
Gas ignition	Automatic with flame sensing circuit
Electrode tip-to-burner air gap	1/8 to 3/16 in.

N62X/N82X Models

Storage volume

N62X	-----	6.3 ft ³ .
N82X	-----	7.5 ft ³ .

Rough opening dimensions (H x W x D)

N62X	-----	52 ⁷ / ₈ in. x 23 ¹ / ₂ in. x 24 in.
N82X	-----	59 ⁷ / ₈ in. x 23 ¹ / ₂ in. x 24 in.

Decorative panels dimensions

Thickness	-----	3/16 in.
Freezer door (H x W, both models)	-----	14 ¹⁷ / ₃₂ in. x 21 ¹⁹ / ₃₂ in.
Fresh food compartment door		
N62X	-----	31 ⁵ / ₈ in. x 21 ¹⁹ / ₃₂ in.
N82X	-----	38 ⁵ / ₈ in. x 21 ¹⁹ / ₃₂ in.

Controls

Type	-----	Electronic with built-in diagnostic mode
ON/OFF/MODE/TEMP SET switches	-----	Flush push-button
Temperature settings	-----	1=cold, 9=coldest
Temperature sensor	-----	Thermistor, fin mounted (10 th fin)

Off-level operating limits

Side-to-side	-----	3 degrees-maximum
Front-to-back	-----	6 degrees-maximum

DC power

Controls operating voltage	-----	10.5 to 15.4 Vdc
Fuse, control circuit (F1 in power board)	-----	5 A (tan color), automotive blade type
Fuse, fan (N6XXF/N8XX F models with in-line fuse)	-----	1 A, 1/4 in. x 1 1/4 in. AGC type fast-acting

DC amperage draws (at nominal 12 Vdc)

Automatic ignition	-----	0.50 A
Divider heater	-----	0.25 A
Fresh food compartment lamp	-----	0.46 A
Gas valve	-----	0.146 A
Fan (N6XX/FN8XXF models only)	-----	0.36 A

AC power

AC heater operating voltage	-----	108 to 132 Vac
Fuse AC heater circuit (F2 in power board)	-----	8 A, 1/4 in. x 1 1/4 in. AGC type fast acting

AC heater rating

Refrigerators with serial numbers lower than 854647	-----	300 W (2.7 A @ 110 Vac) with resistance of 41Ω
Refrigerators with serial numbers 854647 and higher	-----	300 W (2.5 A @ 120 Vac) with resistance of 48Ω

LP gas (propane)

Operating pressure	-----	10.5 to 11.5 in. w.c.
Heat input	-----	1500 Btu/h @ 11 in. w.c.
Orifice, new style	-----	LP16
Orifice, old style	-----	0.155 jeweled
Gas ignition	-----	Automatic with flame sensing circuit
Electrode tip-to-burner air gap	-----	1/8 to 3/16 in.

N64X/N64X.3/N84X/N84X.3 Models

Storage volume

N64X/N64X.3	6.3 ft ³ .
N84X/N84X.3	7.5 ft ³ .

Rough opening dimensions (H x W x D)

N64X/N64X.3	52 ⁷ / ₈ in. x 23 ¹ / ₂ in. x 24 in.
N84X/N84X.3	59 ⁷ / ₈ in. x 23 ¹ / ₂ in. x 24 in.

Decorative panels dimensions

Thickness	3/16 in.
Freezer door (H x W, both models)	14 ¹⁷ / ₃₂ in. x 21 ¹⁹ / ₃₂ in.
Fresh food compartment door	
N64X/N64X.3	31 ⁵ / ₈ in. x 21 ¹⁹ / ₃₂ in.
N84X/N84X.3	38 ⁵ / ₈ in. x 21 ¹⁹ / ₃₂ in.

Controls

Type	Electronic with built-in diagnostic function
ON/OFF/MODE/TEMP SET switches	Raised push-button
Temperature settings	1=cold, 9=coldest
Temperature sensor	Thermistor, fin mounted (10 th fin)

Off-level operating limits

Side-to-side	3 degrees-maximum
Front-to-back	6 degrees-maximum

DC power

Controls operating voltage	10.5 to 15.4 Vdc
DC fuse (F1 in power board)	5 A (tan color), automotive blade type
DC heater rating	225 W/16 A @ 14 Vdc (resistance of 0.87 Ω)
DC heater operating voltage (3-way models only)	12 – 14 Vdc
Fuse, DC heater (F1, in DC Board)	30 A (green color), automotive blade type
Fuse, fan (N6XXF/N8XXF models with an in-line fuse)	1A, 1/4 in. x 1 1/4 in. AGC type fast-acting

DC amp draws (at nominal 12 Vdc)

Automatic ignition	0.50 A
DC heater	13.79 A @ 12 Vdc/16 A @ 14 Vdc
Divider heater	0.25 A
Fresh food compartment lamp	0.46 A
Gas valve	0.146 A
Fan (N6XX/FN8XXF models only)	0.36 A

AC power

AC heater operating voltage requirements	108 to 132 Vac
Fuse AC heater circuit (F2 in power board)	8 A, 1/4in. x 1 1/4in. AGC type fast acting

AC heater rating

Refrigerators with serial numbers lower than 854647	300 W (2.7 A @ 110 Vac) with resistance of 41Ω
Refrigerators with serial numbers 854647 and higher	300 W (2.5 A @ 120 Vac) with resistance of 48Ω

LP gas (propane)

Operating pressure	10.5 to 11.5 in. w.c
Heat input	1500 Btu/h @ 11 in. w.c
Orifice, new style	LP16
Orifice, old style	0.155 jeweled
Gas ignition	Automatic with flame sensing circuit
Electrode tip-to-burner air gap	1/8 to 3/16 in.













TROUBLESHOOTING – QUICK REFERENCE GUIDE

Problem	Possible Cause	Checks/Reference
The refrigerator does not turn ON.	No 12 Vdc power to refrigerator. Faulty/loose 12 Vdc connections. F1 fuse in power board open.	See page 11. Check 12 Vdc connections. Check fuse F1, (5 amp) in power board.
The refrigerator does not cool on AC power.	No AC power to refrigerator. F2 fuse in the power board open. AC heater failed open.	See page 16. Check fuse F2, (8 amp) in power board. See page 18.
The refrigerator does not cool efficiently on AC power.	Ventilation obstructed. AC voltage low.	Check enclosure for air flow obstructions. See page 17.
3-Way Units Only The refrigerator does not cool on DC power.	F1 fuse on DC board open. DC heater failed open.	Check fuse F1 (30 amp) in power board. See page 15.
3-Way Units Only The refrigerator does not cool efficiently on DC power.	Ventilation obstructed. DC voltage below 12 volts.	Check enclosure for obstructed air flow. Check RV 12 Vdc power supply.
The refrigerator does not operate on LP gas.	No LP gas. Incorrect electrode tip-to-burner gap. Faulty spark/sense electrode assembly. Flame sensing circuit failure.	Check LP gas supply and valves. See page 12. See page 12. See page 13.
The refrigerator does not cool efficiently on LP gas.	Ventilation obstructed. Incorrect LP gas pressure. Dirty burner. Missing flue baffle. Heat deflector blocked.	Check enclosure for obstructed air flow. See page 12. See page 12. See page 31. See page 31.
"no" "co" code.	Poor ventilation. Off-level operation. Dirty burner. Low AC voltage. Cooling fan inoperative. Improper installation. Incorrect orifice.	Check enclosure for obstructed air flow. See page 38. See page 31-32. See page 35. See page 36. See pages 23-27. See page 30.











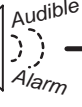

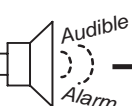
N61X/N81X DISPLAYED FAULT CODES

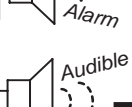
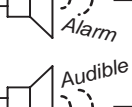
Problem	Probable Cause	Reference
ON LED off.	Refrigerator turned off. No 12 Vdc to refrigerator. F1 fuse open.	See page 11.
ON LED and GAS LED flash off at one second intervals.	In AUTO operation: No AC power or LP gas available GAS operation: Burner failed to ignite or reignite.	See page 16. See page 12.
ON LED on. GAS LED flashes off at one second intervals.	"Gas lock-out." Burner failed to ignite or reignite.	See page 12.
ON LED flashes off once every three seconds.	Back-up system operation.	See page 20.
ON LED flashes off twice every three seconds.	Mode switch failure. Refrigerator operating in last selected mode.	Replace optical control assembly.
ON LED flashes off three times every three seconds.	AC heater failure.	See page 18.
ON LED flashes off four times every three seconds.	Controls failure.	Replace power board.
ON LED flashes off five times every three seconds.	No cooling detected by the controls.	See pages 21 & 38.
ON LED flashes off six times every three seconds.	"Open" High Limit Temperature Switch.	See page 38.

N62X/N82X DISPLAYED FAULT CODES

Code	Probable Cause	Reference
	Refrigerator turned off. No 12 Vdc to refrigerator. F1 fuse open.	See page 11.
	Burner failed to ignite or reignite.	See page 12.
	Flame sense circuit failure.	See page 13.
	DC voltage low.	See page 13.
	DC voltage high.	See page 14.
	AC relay stuck closed.	See page 16.
	Low/No AC power available to refrigerator. AC cord not plugged into power board. F2 fuse open.	See page 16.
	AC heater failed open.	See page 18.
	Fresh food compartment door open more than 2 minutes. Lamp reed relay switch faulty.	See page 19.
	Back-up operating system.	See page 20.
	No cooling detected by the controls.	See page 21.
	“Open” High-Limit Temperature Switch.	See page 11.
	Flame sensed present when it should not be.	See page 11.

N64X/N84X DISPLAYED FAULT CODES

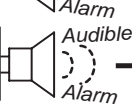
Code	Probable Cause	Reference
Blank Display Screen	Refrigerator turned off. No 12 Vdc to refrigerator. F1 fuse open.	See page 11.
no. FL. 	The burner failed to ignite or reignite.	See page 12.
5r. 	Flame sense circuit failure.	See page 13.
dc. LO. 	DC voltage low.	See page 13.
dc. rE. 	DC relay stuck closed, 3-way models only .	See page 14.
dc. HI. 	DC voltage high.	See page 14.
dc. HE. 	DC heater failure, 3-way models only .	See page 15.
no. AC. 	No AC power available to refrigerator. AC cord not plugged into power board. F2 fuse open.	See page 16.
AC. rE. 	AC relay stuck closed.	See page 16.
AC. LO. 	AC voltage low.	See page 17.
AC. HI. 	AC voltage high.	See page 17.
AC. HE. 	AC heater failed open.	See page 18.
dr. 	Fresh food compartment door open more than 2 minutes. Lamp reed relay switch faulty.	See page 19.
Flashing Temp Setting	Back-up operating system.	See page 20.
no. co. 	No cooling detected by the controls.	See pages 21 & 38.
FL. --. 	Flame present when it should not be.	See page 11.
op. LI. 	"Open" High Limit Temperature Switch.	See page 38.
dc. Er. 	The DC Board has lost communication with the Power Board.	See page 14.

TROUBLESHOOTING FAULT CODES

FL --/ Fault Code – Flame
present when it should not be.

This fault indicates the gas valve is stuck open. Inspect gas valve operation and replace if necessary.

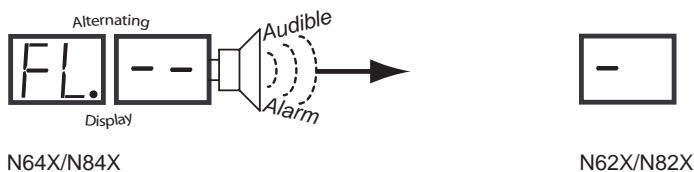

OP LI/o Fault Code – "Open"
high limit temperature switch.

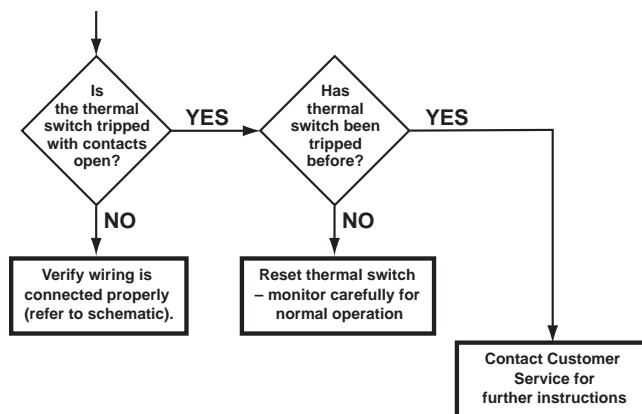
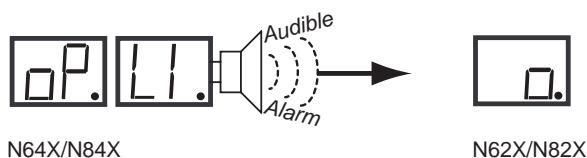

TROUBLESHOOTING FLOWCHARTS

Blank Display – Refrigerator does not turn on

Before beginning this procedure make sure:

- The RV DC power system is supplying 10.5 to 15.4 volts to the refrigerator.
- No other RV appliances or lighting circuits are connected to the refrigerator DC circuit.
- 12 Vdc input to the power board is wired according to the N6XX/N8XX installation manual.

Models and fault indicator displayed.

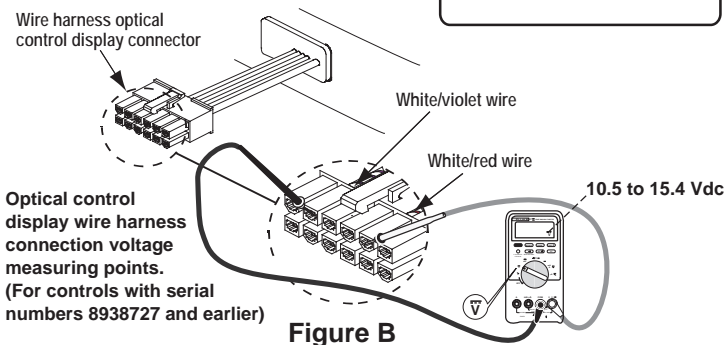
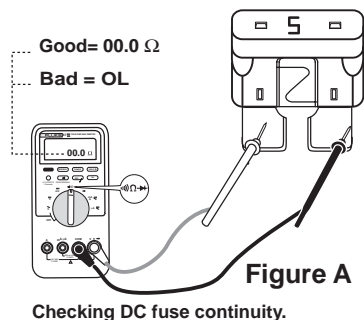
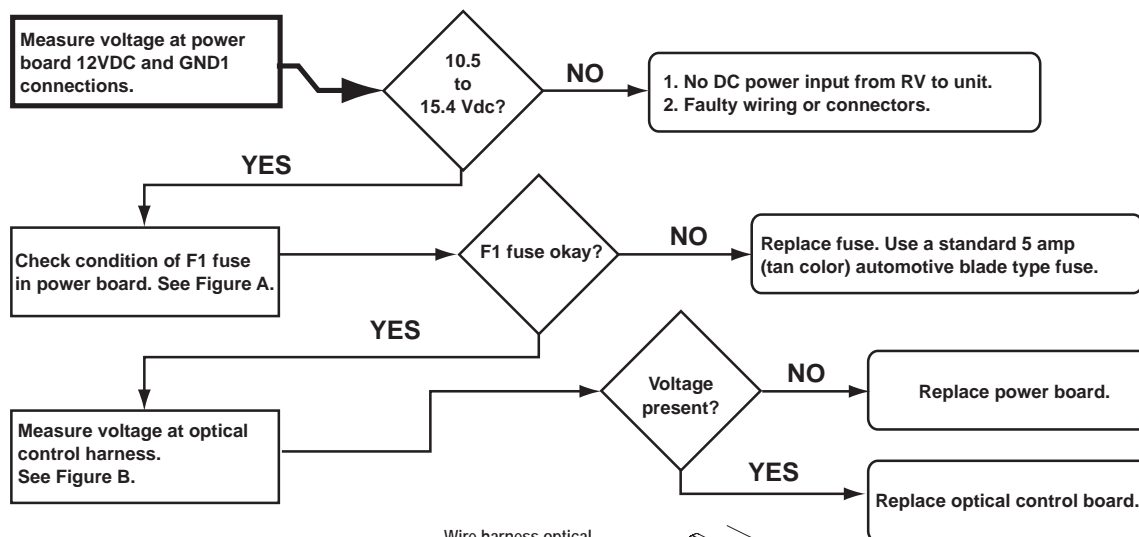

F/no FL Fault Code – Burner failed to ignite or reignite

Before beginning this procedure make sure:

- RV LP gas tank valve is open.
- Refrigerator solenoid gas valve manual shutoff is open.
- LP gas pressure at the solenoid gas valve pressure tap is 10.5.

Models and fault indicator displayed.

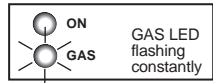

N61X/N81X



N62X/N82X

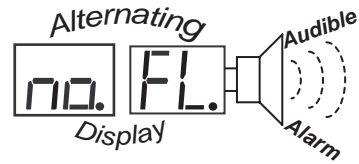

N64X/N84X

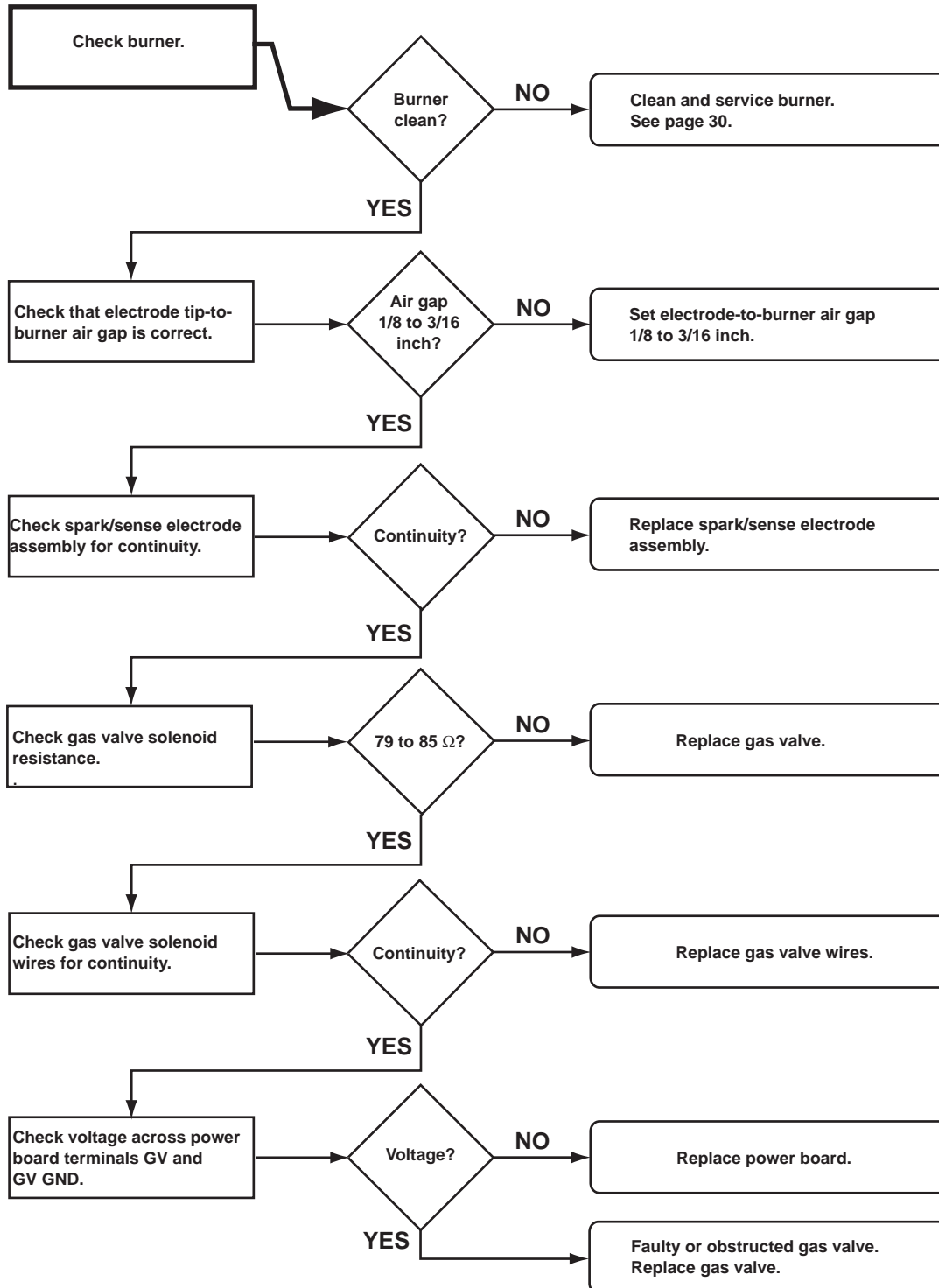

S/Sr Fault Code – Flame sense circuit failure

Models and fault indicator displayed.

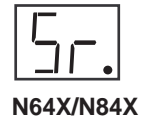

dc LO Fault Code – Low DC voltage

Before beginning this procedure:

- Make sure RV DC voltage to refrigerator is 10.5 to 15.4 volts.
- Determine if the DC LO fault code displays when the converter is the source of DC power.
- Make sure no other appliance or lighting circuit is connected to the refrigerator DC circuit.

Models and fault indicator displayed.

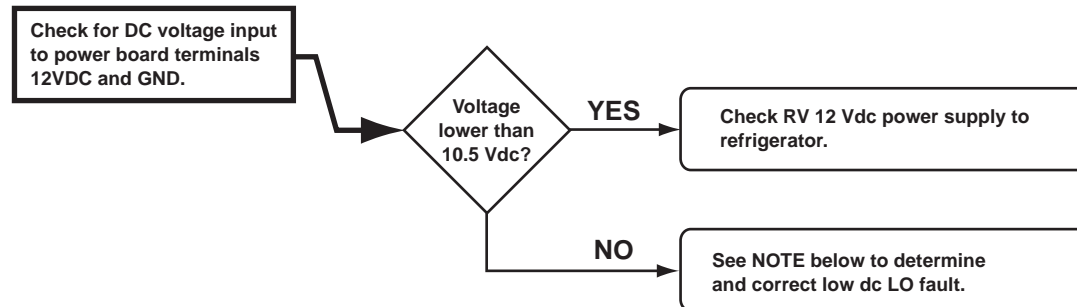
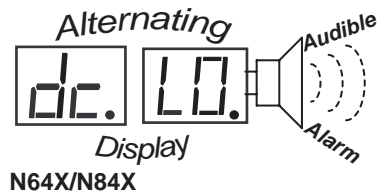

NOTE

Electric controls operate on 12 Vdc. When an AC/DC converter is used to supply DC power, the refrigerator circuit must be connected to the appliance output terminals of the converter (filtered side).

If the refrigerator circuit is connected to the unfiltered side, the AC ripple generated by the converter may cause a dc LO fault code to display.

To troubleshoot a dc LO fault, connect a charged 12-volt automotive battery to the power board. If the dc LO code clears, the fault was caused by unfiltered DC power.

If the dc LO code does not clear, replace the power board.

dc Er Fault Code – DC board lost communication with power board

Models and fault indicator displayed.

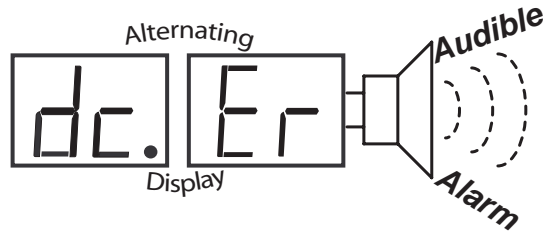

N64X/N84X

The only time this error can occur is while operating in the DC manual mode of operation.

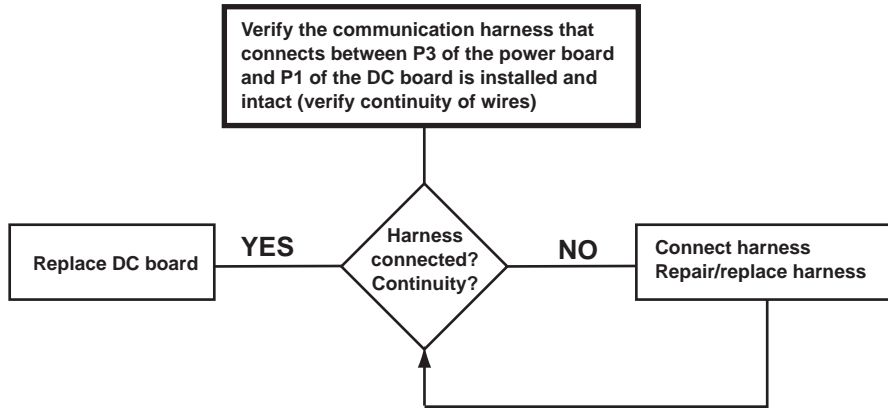

dc rE Fault Code – DC relay stuck closed

Models and fault indicator displayed

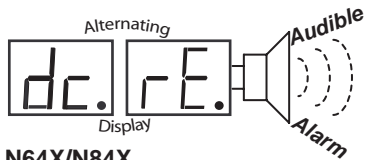

N64X/N84X

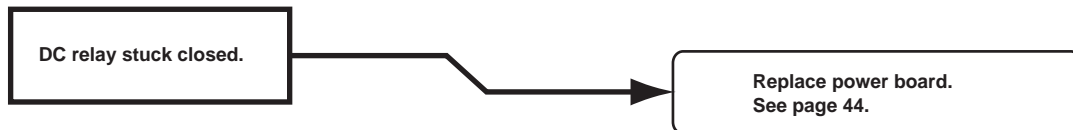

dc HE Fault Code – DC heater failed open

Before beginning this procedure make sure:

- The RV DC electrical system is maintaining 10.5 to 15.4 Vdc to the refrigerator.
- No other appliance or lighting circuit is connected to the refrigerator DC circuit.

Model and fault indicator displayed.

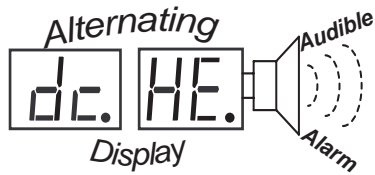

N64X.3/N84X.3

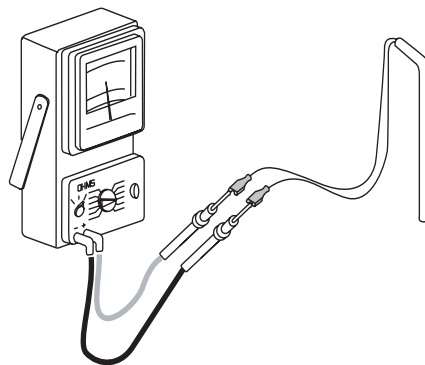
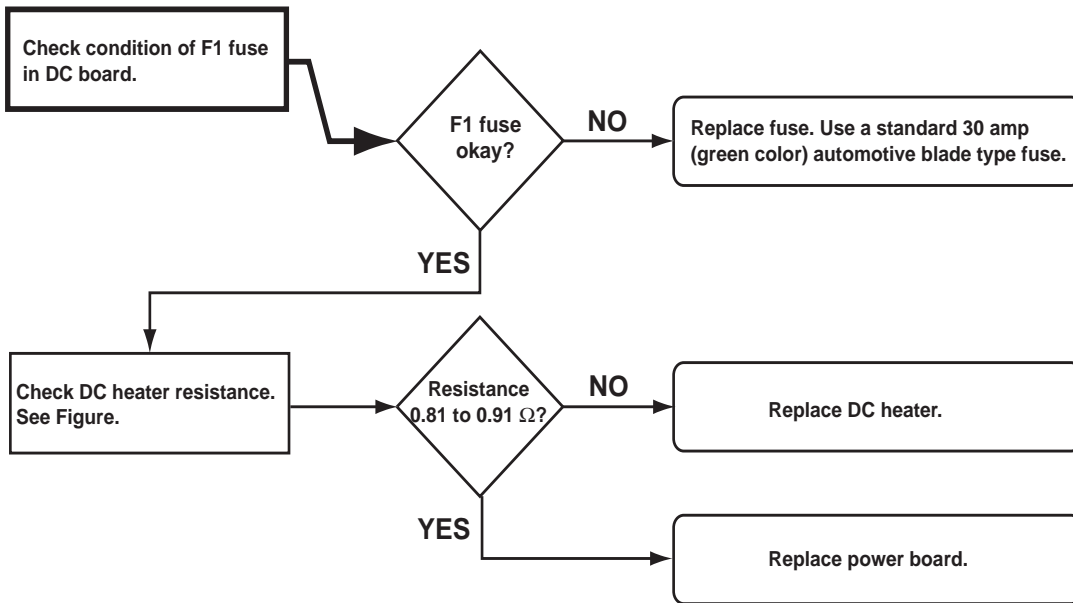

DC heater resistance 0.81 to 0.91Ω.

A/no AC Fault Code – No AC power available/AC power is less than 85V AC

Before beginning this procedure make sure:

- No other problem exist with the RV AC power supply.
- No other appliances or lighting circuits are connected to the refrigerator AC circuit.
- Extension cords are not being used to supply AC power to the refrigerator.

Models and fault indicator displayed.

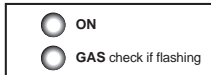

Does not operate on AC when set to AUTO.

N61X/N81X



N62X/N82X

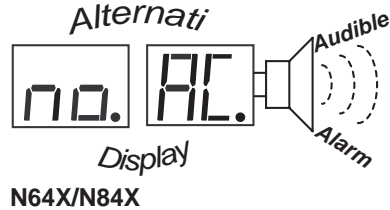

N64X/N84X

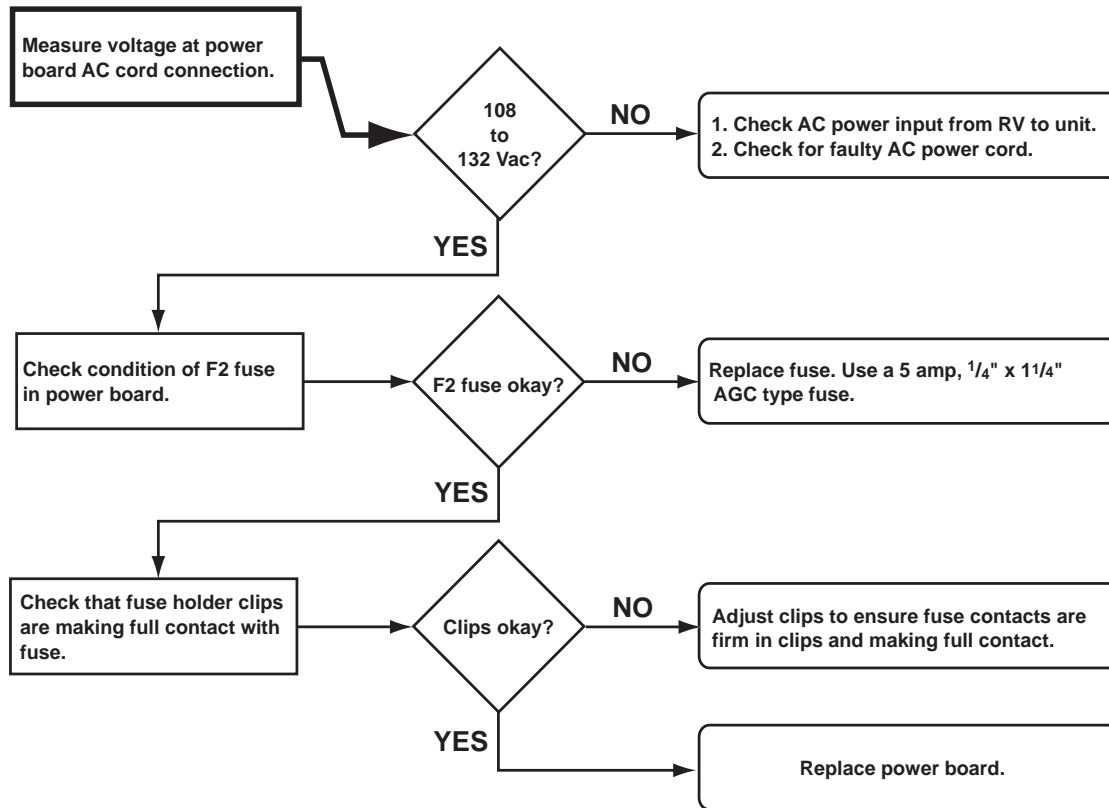

r/AC rE Fault Code – AC relay stuck closed

Models and fault indicator displayed.



N62X/N82X

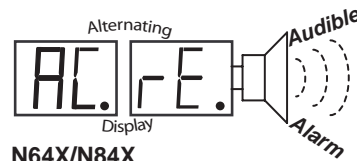

N64X/N84X



AC LO Fault Code – AC voltage low

Before beginning this procedure:

- Determine if a certain AC power source sets the AC LO fault code (generator, shore power, inverter).
- Make sure no other appliance or lighting circuit is connected to the refrigerator AC circuit.
- Make sure extension cords are not being used to supply AC power to the refrigerator.

Model and indicator displayed.

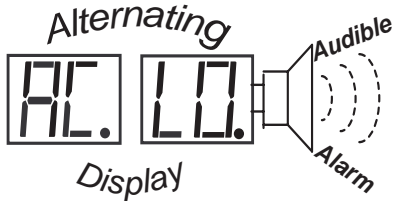

N64X/N84X

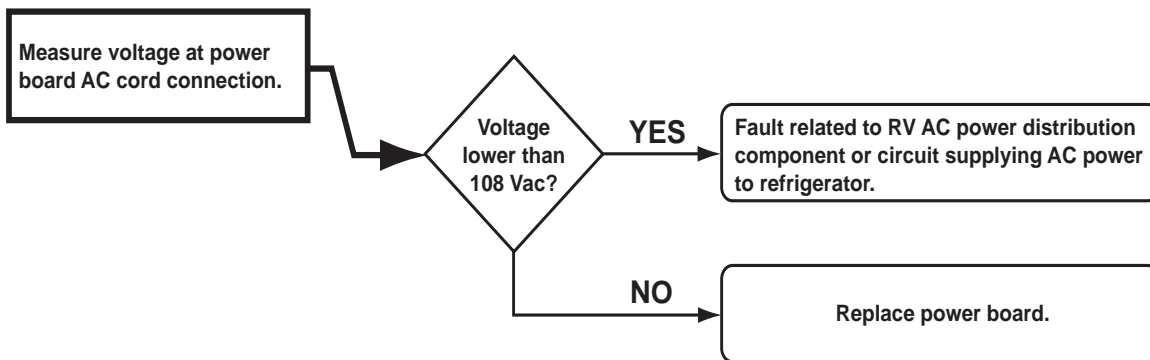

AC HI Fault Code – AC voltage high

Before beginning this procedure:

- Determine if a certain AC power source sets the AC HI fault code (generator, shore power, inverter).

Model and indicator displayed.

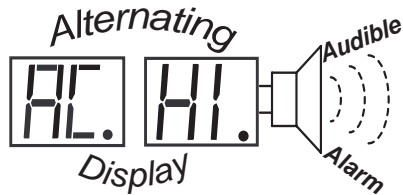

N64X/N84X

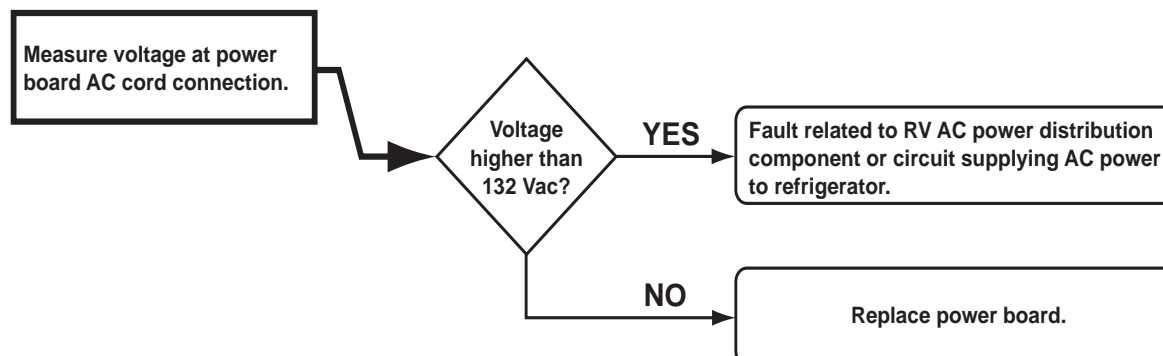

H/AC HE Fault Code – AC heater failed open

Before beginning this procedure make sure:

- RV AC voltage to the refrigerator is 108 to 132 volts.
- No other appliance or lighting circuit is connected to the refrigerator AC circuit.

Models and indicator displayed.

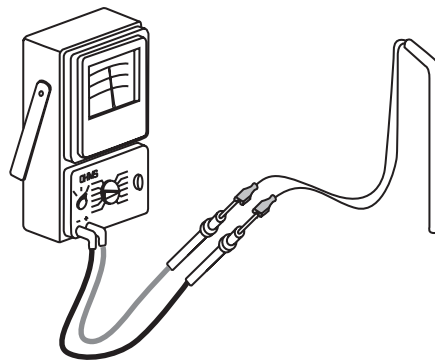
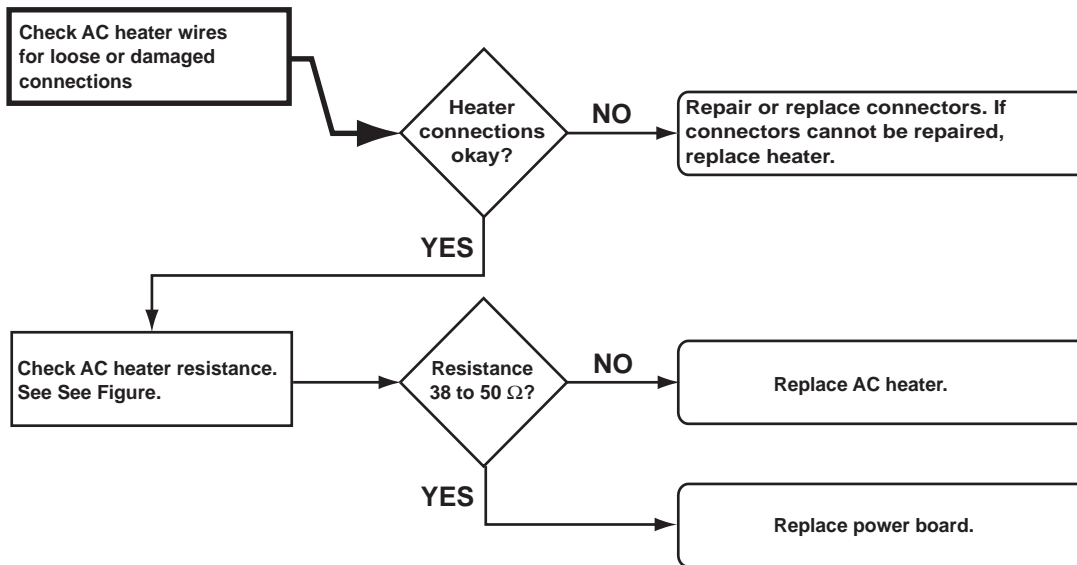

AC heater resistance 38 to 50 Ω .

d/dr Fault Code – Door open for more than 2 minutes

Before beginning this procedure make sure:

- Light/thermistor connector and wire harness connector are full engaged and locked

Models and fault indicator displayed.

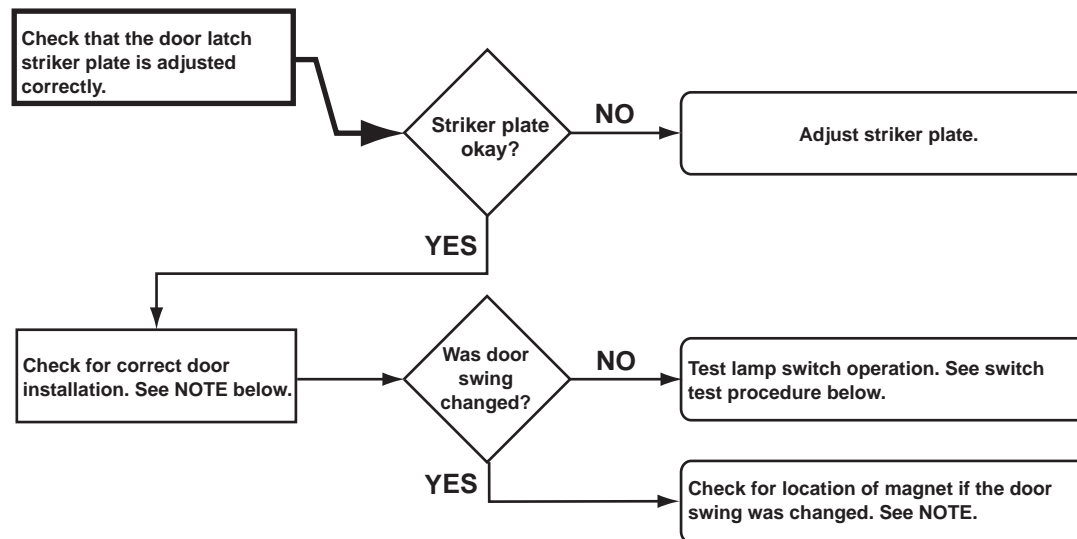
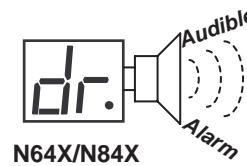

Food Compartment Lamp Switch

The reed switch that turns the fresh food compartment light on and off is an integral component of the optical control display board circuitry.

Lamp Switch Operation

The magnetic pull from a permanent magnet located underneath the top door trim maintains the switch contacts open (light off) when the door is fully closed. Opening the door breaks the magnetic pull, which in turn causes the switch contacts close (light on).

NOTE

Always follow the instructions provided in the Owner's Manual to change the refrigerator door swing. The bottom door trim does not have a magnet. Inverting the doors will require non-approved modifications and will cause the fresh food compartment light to remain on when the door is closed.

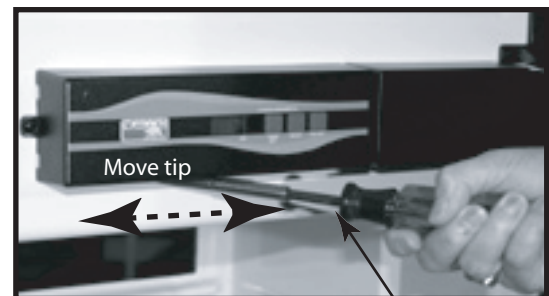

Magnetic tip screwdriver

Lamp Switch Testing Procedure

1. Slide a magnetic screwdriver tip or a small magnet on the underside of the optical control assembly as shown in the figure above.
2. Check the food compartment light as the screwdriver tip is moved under the display, the light:
 - a. should turn off when the magnetic screwdriver tip or magnet passes under the optical control assembly.
 - b. turn on when the magnetic screwdriver tip or magnet is distanced from the underside of the optical control assembly.
3. If the light does not turn off when the magnet passes under the optical control display, replace the optical control display assembly.

Thermistor Failure Fault – Controls in backup operating system mode

Before beginning this procedure:

- Make sure lamp/thermistor assembly is connected to wire harness.

Models and fault indicator displayed.

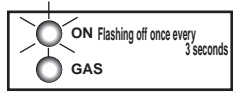

N61X/N81X

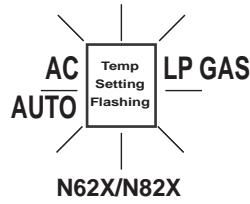

N62X/N82X

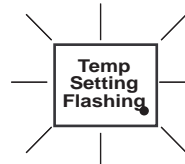

N64X/N84X

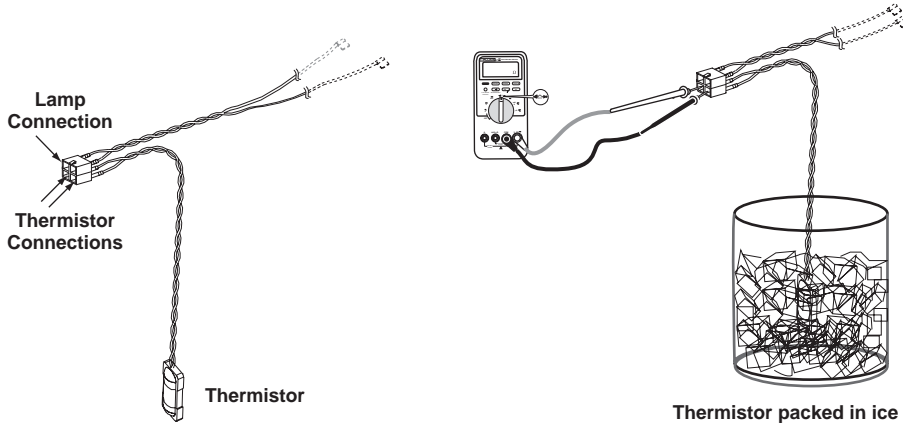
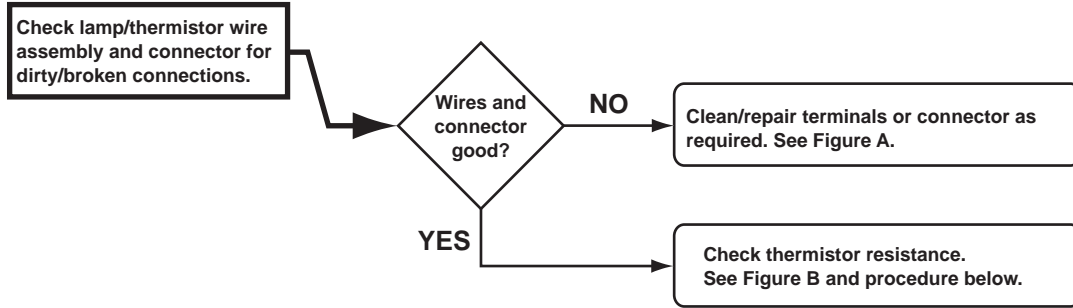

Figure A.

Thermistor packed in ice bath

Figure B.

Temperature* (°F)	Resistance* (kΩ)
85	8.1 to 9.0
80	9.1 to 10.0
75	10.1 to 11.0
70	11.1 to 12.0
60	12.1 to 13.0
50	15.5 to 16.5
40	22.5 to 23.5
35	24.5 to 25.5
33	28.5 to 29.5
32	30.0 to 32.0

*Approximate Values

Backup Operating System (BOS)

The backup operating system (BOS) is an electronically controlled duty cycle that maintains the refrigerator in operation if the thermistor is disconnected or fails. The BOS maintains cooling by timing the length of time the heat source is energized. When the refrigerator is operating in BOS, the length of the cooling cycle has to be regulated manually using the TEMP switch/button.

When a colder temperature is desired, changing the temperature setting to a higher number provides additional cooling by lengthening the cooling cycle. For example, if the temperature setting is set to 5, raising the setting to 6 will lengthen the cooling cycle.

When a warmer temperature is desired, changing the

temperature setting to a lower number shortens the cooling cycle. For example, if the temperature setting is set to 6, lowering the setting to 5 will shorten the cooling cycle.

N61X/N81X Backup Operation.

When the N61X/N81X controls shift to BOS operation, the ON LED (green) flashes off once every three seconds.

N62X/N82X/N64X/N84X Backup Operation

When the N62X/N82X/N64X/N84X controls shift to BOS operation, the temperature setting flashes for ten seconds when the TEMP button is pressed. After ten seconds, the selected operation mode indicator displays.

n/no co Fault Code – No cooling detected by the controls

Models and indicator displayed.

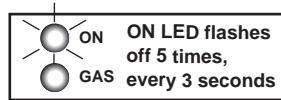

N61X/N81X



N62X/N82X

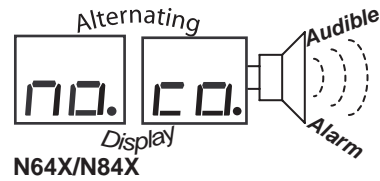

N64X/N84X

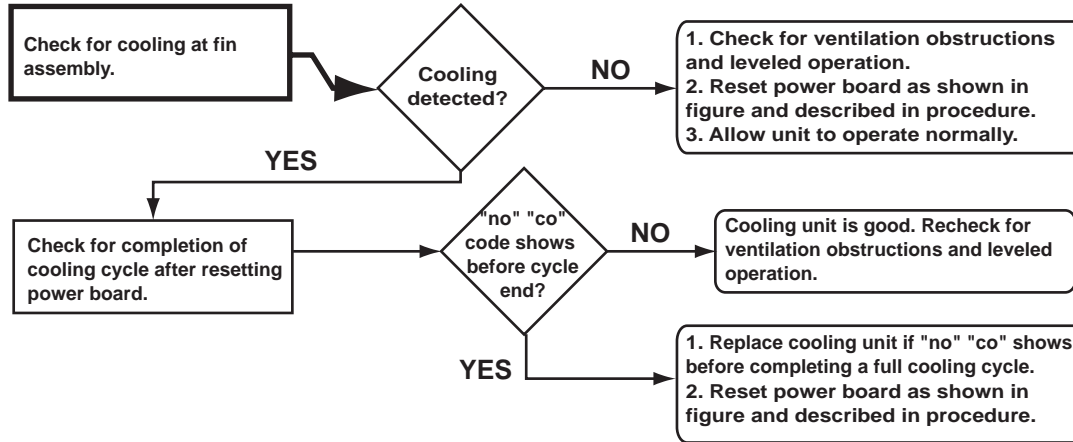

Power Board Reset Procedure 1

The power board can be reset by jumpering pins on the power board on earlier controls of these refrigerators:

Model	Serial No.	Manufacture Date
N61/N81	9056491 and lower	Before 3/23/2006
N621/N821	9126824 and lower	Before 4/11/2006
N623/N823	8970880 and lower	Before 3/1/2006
N64/N84	9044283 and lower	Before 3/22/2006
N64.3/N84.3	8938727 and lower	Before 2/21/2006

- Turn OFF the refrigerator.
- Disconnect the following from power board:
 - 12 Vdc positive and negative wires.
 - AC power cord.
 - Solenoid gas valve wires
 - Spark/sense electrode assembly wires.
- Remove the power board cover.
- Reconnect 12 Vdc positive and negative wire.
- Turn ON the refrigerator.
- Locate Pin 15 on 16-pin connector (P1). Pin 15 is the empty socket to the right of the white/violet wire on the top row. See Figure C.
- Using an insulated jumper wire, short Pin 15 to the power board ground lug for 10-15 seconds. A clicking sound indicates the controls are reset. See Figure C.
- Turn OFF the refrigerator.
- Turn ON the refrigerator. If "n" or "no co" code displays, repeat steps 7-9.
- Turn OFF the refrigerator.
- Disconnect the 12 Vdc power positive and negative wires from the power board.
- Install the power board cover.
- Reconnect the following to the power board:
 - Spark/sense electrode assembly wire.
 - Solenoid gas valve wires
 - AC power cord.
 - 12 Vdc positive and negative wires from the power board.
- Place refrigerator in service.

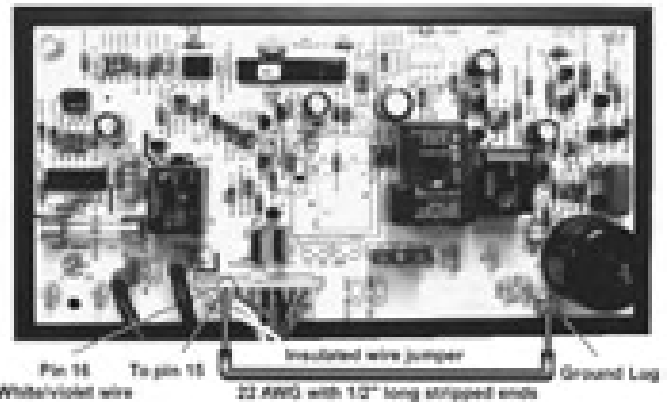

Figure C – Reset Procedure 1.

NOTE

A jumper wire to short Pin 15 to ground can be made from a six inch long insulated 22 AWG wire with a 1/2 inch of insulation stripped from each end.

Power Board Reset Procedure 2

The power board can be reset through the optical display using Procedure 2 on these refrigerators:

Model	Serial No.	Manufacture Date
N61/N81	Not applicable	Not applicable
N621/N821	9126824 and higher	After 4/11/2006
N623/N823	8970880 and higher	After 3/1/2006
N64/N84	9044283 and higher	After 3/22/2006
N64.3/N84.3	8938727 and higher	After 2/21/2006

Entering the diagnostic mode of operation and then **clearing fault history screen 6** resets the no cool error. This procedure is found on page 66.

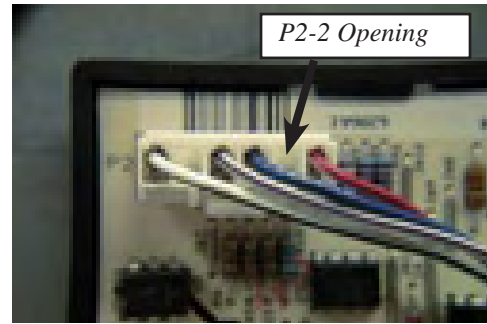

Figure D – Reset Procedure 3.

Power Board Reset Procedure 3

Procedure 3 pertains to these refrigerators:

Model	Serial No.	Manufacture Date
N61/N81	9056492 and higher	After 3/23/2006
N621/N821	9126825 and higher	After 4/11/2006
N623/N823	8970881 and higher	After 3/1/2006
N64/N84	9044284 and higher	After 3/22/2006
N64.3/N84.3	8938728 and higher	After 2/21/2006

1. Turn OFF the refrigerator.
2. Disconnect the following from power board:
 - a. 12 Vdc positive and negative wires.
 - b. AC power cord.
 - c. Spark/sense electrode assembly wires.
3. Remove the power board cover.
4. Reconnect 12 Vdc positive and negative wire.
5. Turn ON the refrigerator. It should be operating in the Manual AC mode (AC power cord disconnected from the power board).
6. Insert one end of a piece of multi-stranded wire (10 gauge works well) whose insulation is stripped 1/2" on both ends, into the P2-2 opening and hold into place.
7. Place the other end of the multi-stranded wire to ground (metal back panel) and hold it in place for a minimum of 10 seconds.
8. Turn OFF the refrigerator.
9. Turn ON the refrigerator. If "n" or "no co" code displays, repeat steps 7-9.
10. Turn OFF the refrigerator.
11. Disconnect the 12 Vdc power positive and negative wires from the power board.
12. Install the power board cover.
13. Reconnect the following to the power board:
 - a. Spark/sense electrode assembly wire.
 - b. AC power cord.
 - c. 12 Vdc positive and negative wires from the power board.
14. Place refrigerator in service.

VENTILATION

Roof Exhaust Venting

NOTE

The general guidelines for intake vents and roof exhaust vents presented in this section do not replace the instructions and/or guidelines provided in the N6XX/N8XX model refrigerator installation manual and the *Ventilation Guidelines For Gas/Electric Refrigerators*, part number 622090A (3-01). Refer to the N6/N8 installation manual and *Ventilation Guidelines For Gas/Electric Refrigerators* for the latest information on approved vents, installation instructions, and special construction exceptions.

Air Intake Vent

The ventilation and combustion air flow into the enclosure through the air intake vent. See Figures 3 and 4.

The space between the air intake vent and the rear of the refrigerator must be kept clear at all times. Any obstruction in this area may cause serious ventilation problems. The air intake vent opening is also the access for servicing cooling unit components.

Roof Exhaust Vent

The heat absorbed by ventilation air and combustion gases flow out of the enclosure through the roof exhaust vent. See Figures 3 and 4.

The roof exhaust vent is equipped with non removable metal mesh screen that prevent leaves, debris, birds or rodents from getting into the enclosure. The roof cap is fastened to the exhaust vent with four screws. The cap is always installed with the slope towards the front of the RV.

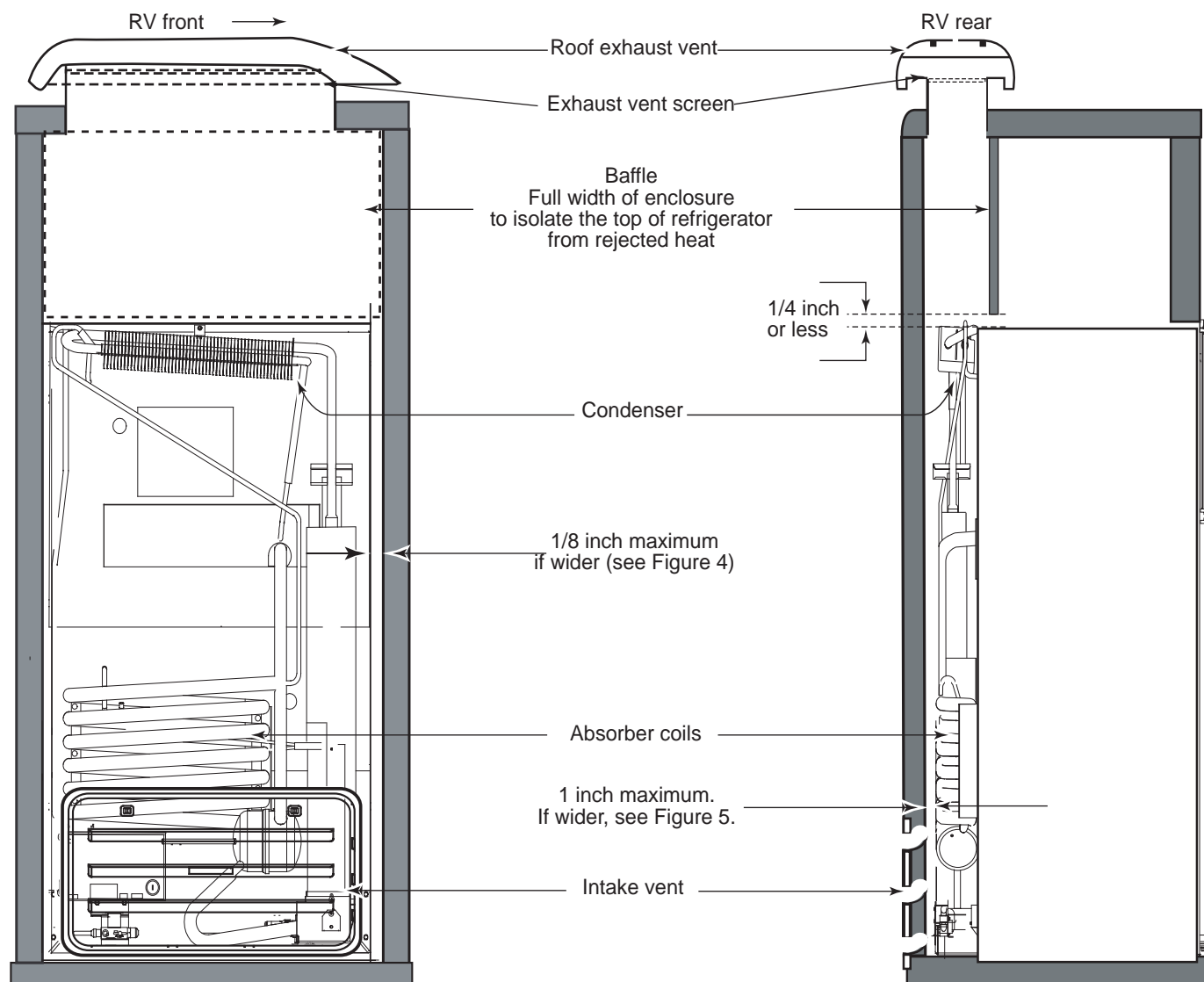

Figure 3. Roof Exhaust Venting Arrangement.

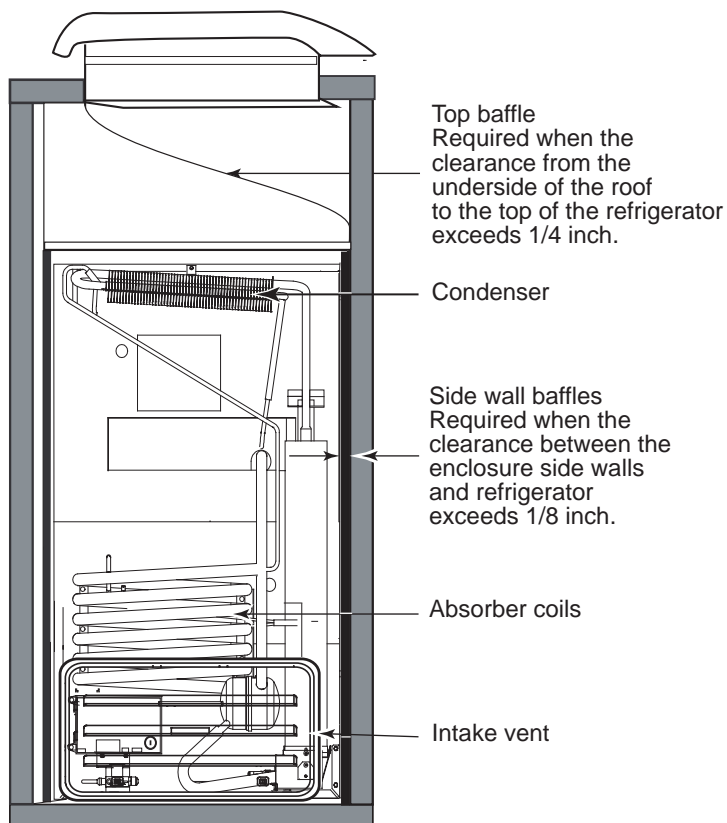

Figure 4. Rear View-Roof Exhaust Venting.

Baffles

The minimum and maximum clearances for installing the refrigerator or correcting ventilation problems on roof vented units are listed in Table 1. Baffles are required whenever installations exceed maximum clearances listed in Table 1. Figure 4 shows baffle locations.

Vertical Angled Baffles

Vertical angled baffles are required when the roof exhaust vent is installed inboard of the condenser. Figure 5 shows the angled vertical baffles required on inboard roof vent installations. The horizontal wall baffles are required whenever the distance between the cooling unit and the interior surface of the outside wall exceeds one inch.

	Minimum	Maximum
Bottom	0 inch	0 inch
Sides (each)	0 inch	1/8 inch
Top	0 inch	1/4 inch
Rear	0 inch	1 inch

Table 1. Clearances for Roof Vented Installations.

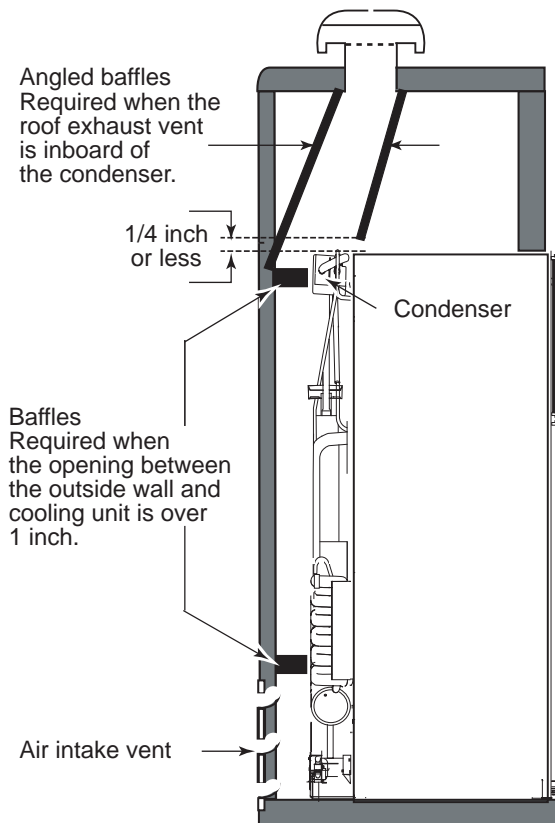

Figure 5. Baffles Required for an Inboard Roof Exhaust Vent Installation.

Double Sidewall Venting

NOTE

The general guidelines for intake vents and roof exhaust vents presented in this section do not replace the instructions and/or guidelines provided in the N6XX/N8XX model refrigerator installation manual and the *Ventilation Guidelines For Gas/Electric Refrigerators* part number 622090A (3-01). Refer to the N6XX/N8XX installation manual and *Ventilation Guidelines For Gas/Electric Refrigerators* for the latest information on approved vents, installation instructions, and special construction exceptions.

With increased installation of refrigerators in RV slide outs, NORCOLD has conducted extensive testing to develop venting guidelines for double sidewall vent applications. This work was done to ensure NORCOLD refrigerators meet the ANSI Z21.19 standards for cooling performance when used in slide out applications.

The challenge with slide out installations is that the "chimney effect" that is present with roof vent installations is not as strong in slide outs. To improve the "chimney effect" side vent installations must have fans and baffles. These fans and baffles direct the air flow through the surfaces of heat rejecting components. NORCOLD has determined that the following three key design considerations optimize heat removal in slide out applications.

- Refrigerators installed in slide outs must have a fan or fans to assist air flow. Fan kits and refrigerators with factory installed fan(s) are available from NORCOLD.
- Fresh air must be directed to flow through the surface areas of the absorber coils, condenser fins, and the outer surface of the canister.
- Corners and structural pockets where heated air may stagnate must be reduced in size or completely eliminated.

An additional challenge with double sidewall venting is the depth of the enclosure. The deeper the enclosure, the greater the impact on the air flow through the rear of the refrigerator. Taking the three key design considerations and the variable depth requirement into account, NORCOLD developed and tested several baffle arrangements for the N6XX and N8XX models versus their ability to meet the ANSI standards.

As the result of this testing, NORCOLD was able to reduce the baffle configuration down to two baffles for the N6XX and N8XX models. It should be noted that baffle arrangements are different if the enclosure depth is greater or less than 26 inches. The baffle configurations are shown in Figures 6 (page 26) and 7 (page 27).

Air Intake Vent

The ventilation and combustion air flow into the enclosure through the air intake vent. See Figures 6 and 7.

Sidewall Exhaust Vent

The heat absorbed by ventilation air and combustion gases flow out of the enclosure through the sidewall exhaust vent. See Figures 6 and 7 for details.

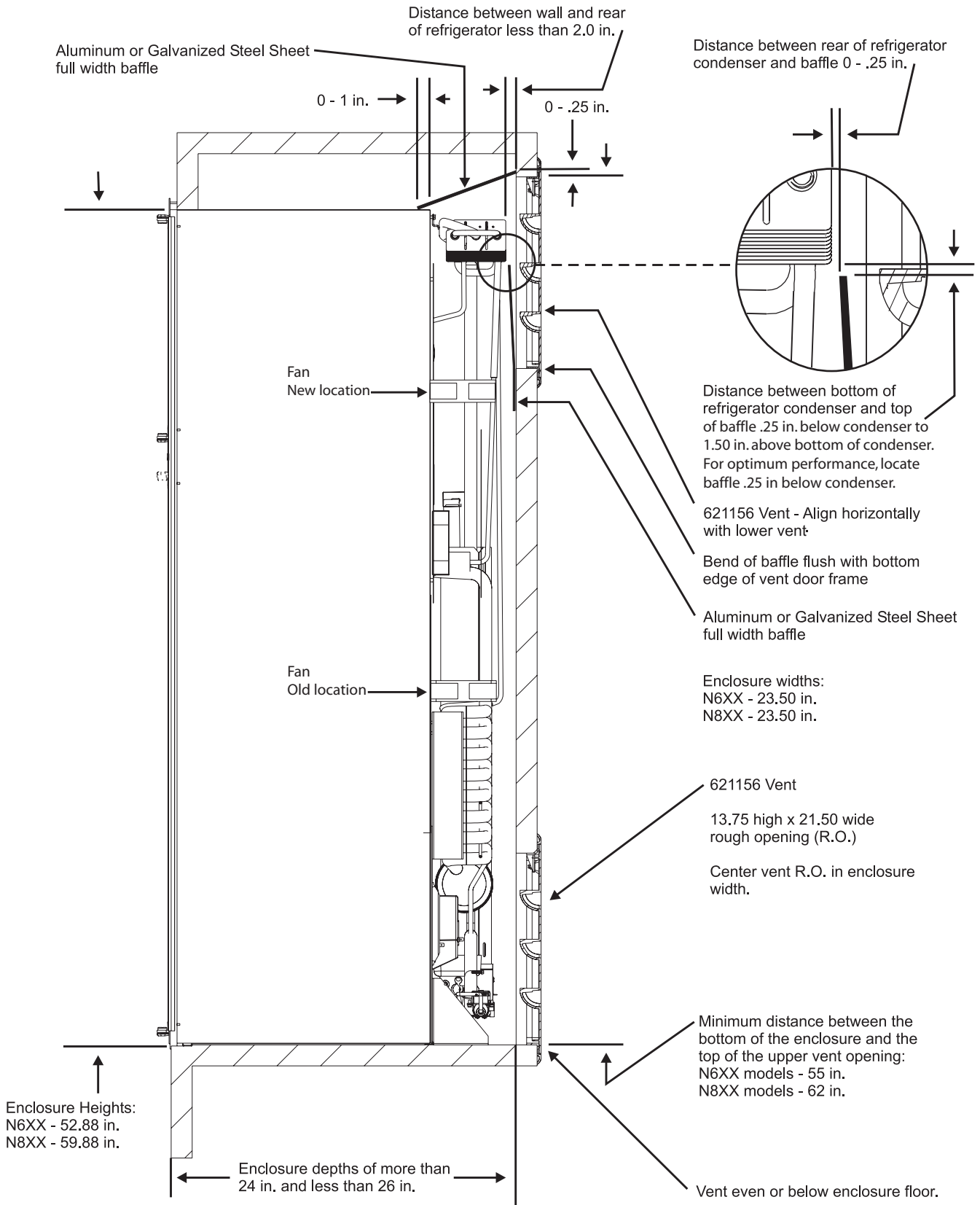

Figure 6. Baffle Arrangement for Enclosures Depths of More than 24 Inches and Less than 26 Inches.

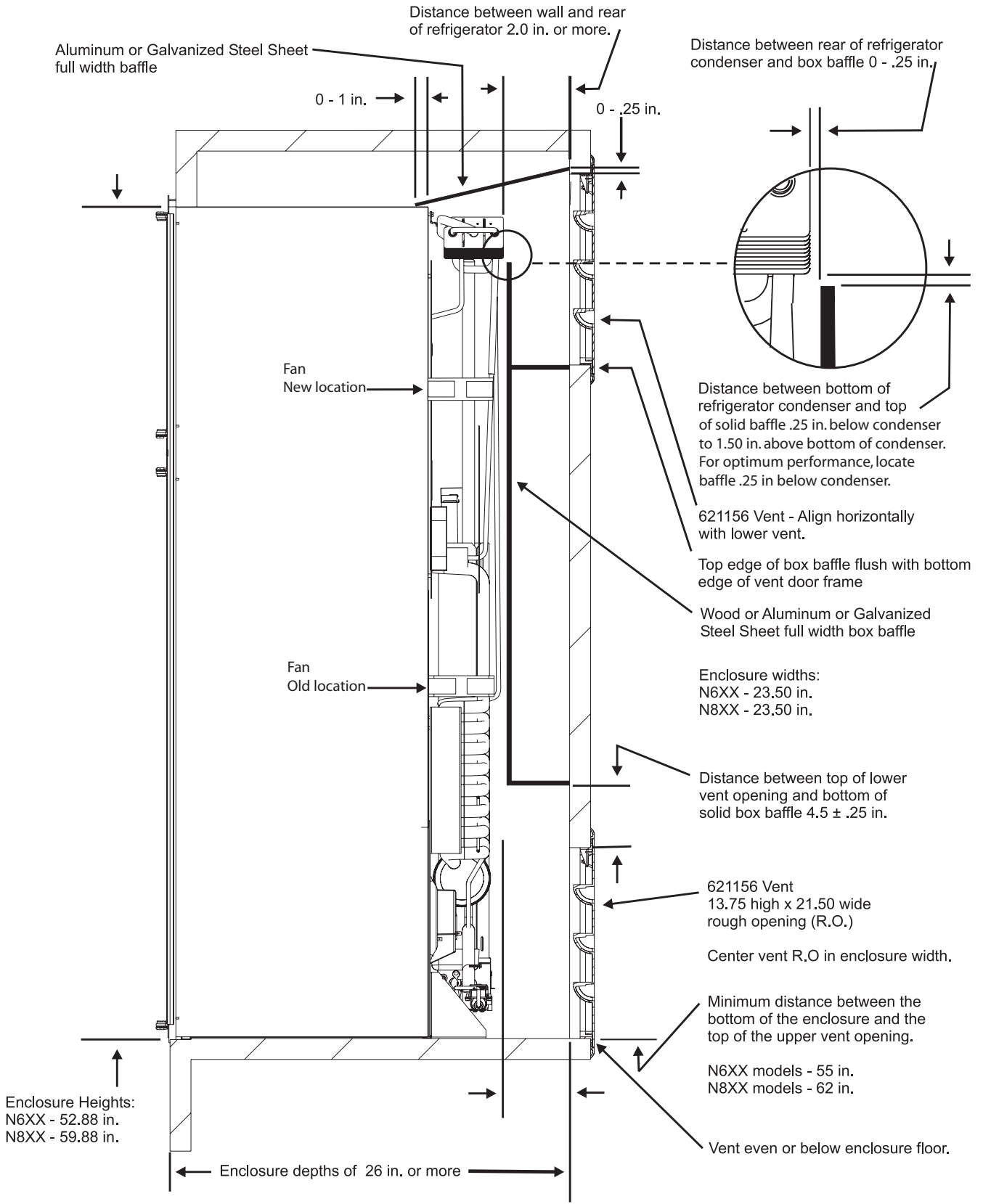

Figure 7. Baffle Arrangement for Enclosures with Depths of 26 Inches or Greater.

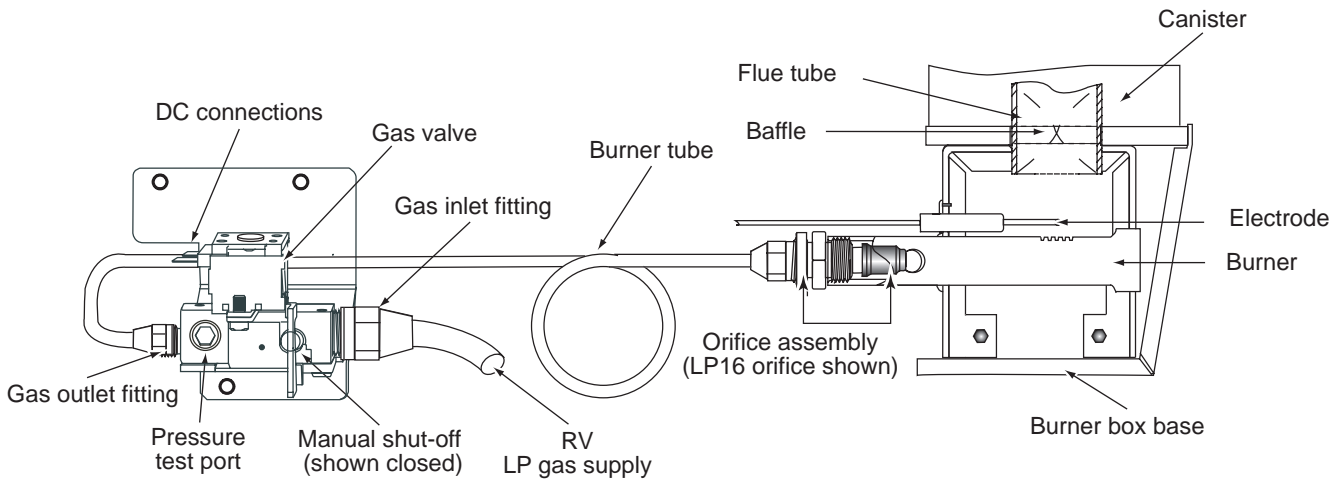

Figure 8. LP Gas System Components (shown with Style B solenoid gas valve).

Pressure Requirements



WARNING:

When working on or near the LP gas system:

- Do not smoke or light fires! Extinguish all open flames!
- Do not use an open flame to leak test any of the LP gas system components. LP gas is highly flammable and explosive.
- Do not connect the refrigerator directly to the LP gas tank. Always use an approved pressure regulator between the LP gas tank and the refrigerator LP gas system.
- To prevent damage to connections, piping, and components, always use two wrenches to tighten or loosen connections. Damaged connections, piping, and components create the potential for gas leaks.

Testing for LP Gas Leaks



WARNING:

Do not wet or spray liquids on or near electrical connections or electronic components. Many liquids, including leak detection solutions, are electrically conductive and can create an electric shock hazard, short electrical components, and/or damage electronic circuits.



CAUTION:

Do not use leak test solutions that contain ammonia or chlorine. Ammonia and chlorine attack copper and brass components.

The refrigerator LP gas system, shown in Figure 8, is for propane gas use only. The system working pressure is 10.5 and 11.5 in. water column. Propane gas pressures below 10.5 in. w.c. or above 11.5 in. w.c. will affect heat output which in turn will affect cooling efficiency. Propane gas flow control is monitored by electronically by the controls flame sensing circuit. If the flame sensing circuit does not detect a burner flame within 30 seconds after initiating ignition, power to the gas valve is turned off and gas mode is locked out.

Leak testing can be accomplished using an electronic leak detector or a commercial grade leak test solution. The use of home made soap and water leak test solution should be avoided if possible. When applying leak test solutions, apply the solution over the entire joint using a small brush or spray applicator.

Due to low system operating pressure, it may take a few minutes for bubbles to appear if the connection is leaking. Hidden joints should be examined thoroughly using an inspection mirror.

Components

When working on the refrigerator LP gas system:

- Do not alter or modify the burner tube anti-vibration loop.
- Do not cross thread fittings. Exercise extreme care when connecting and disconnecting propane gas components.
- Leak test all of the refrigerator propane gas system fittings after servicing, replacing, or repairing any LP gas system component.

Solenoid Gas Valves

Norcold refrigerators have been manufactured with three different solenoid gas valves.

Units with serial numbers lower than 657908 (manufacture dates before Feb. 16, 1999) have Style A solenoid gas valves.

Units with serial numbers between 657908 and 9185699 have Style B solenoid gas valves.

Units with serial numbers higher than 9185699 (manufacture dates after April 25, 1999) have Style C solenoid gas valves.

In all cases, the electronic control automatically operates the solenoid gas valve.

Style A Solenoid Gas Valves

Refrigerators with serial numbers lower than 657908 (manufactured before Feb. 16, 1999) are equipped with the old-style solenoid gas valve.

Style B Solenoid Gas Valves

The manual shut-off valve and the pressure tap are integrated into the Style B solenoid gas valves. The valve's manual shut-off is a spring-loaded, quarter-turn, manually-operated valve. To manually shut-off gas to the burner, pull the handle slightly away from the body, then turn it one-quarter turn (90 degrees) counterclockwise.

Style C Solenoid Gas Valves

The manual shut-off valve and the pressure tap are also integrated into the Style C solenoid gas valves. To manually shut-off gas to the burner, rotate the knurled shut-off knob one-quarter turn (90 degrees) clockwise until the screw slot on the face of the knob is vertical or perpendicular to the flow of gas.

Solenoid Gas Valve Connections

The solenoid gas valve inlet fitting is 3/8 inch, male threads; the outlet fitting is 1/4 inch, male threads.

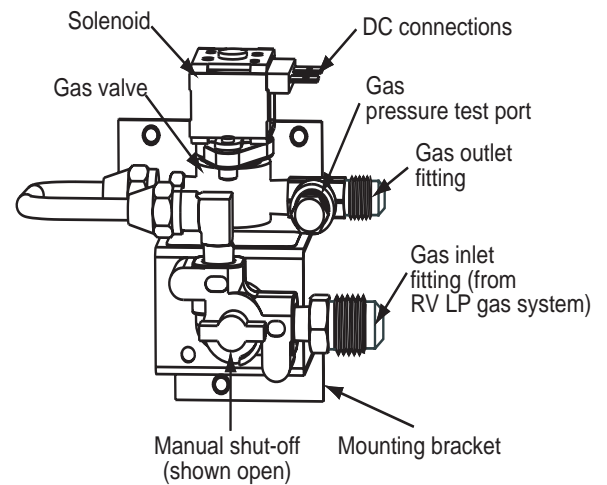

Style A Solenoid Gas Valve.

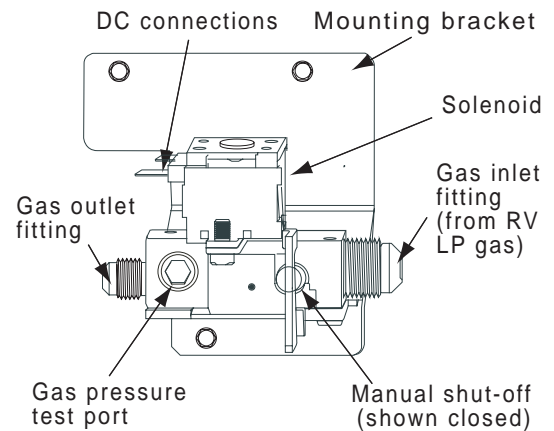

Style B Solenoid Gas Valve.

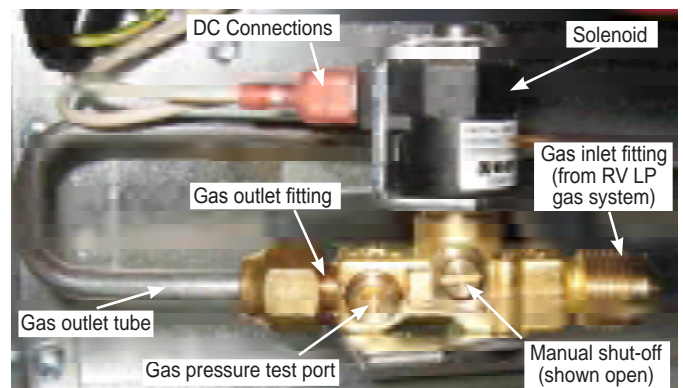

Style C Solenoid Gas Valve.

Orifice

The orifice controls the flow of propane gas to the burner. When replacing the orifice always use the size orifice specified. Using the wrong size or a damaged orifice will alter the amount of propane flowing to the burner.

N62X/N64X units with serial number 886961 and higher and N82X/N84X units with serial number 889988 and higher are equipped with an LP16 cap type orifice. All other units with serial numbers lower than those listed were originally equipped with an 0.155 jeweled orifice. See Figure 11.

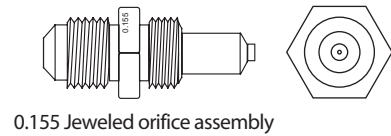

0.155 Jeweled orifice assembly

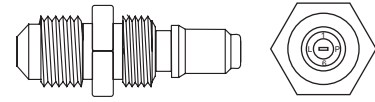

Cap type LP16 orifice assembly

Figure 11. LP16 orifice assemblies.



WARNING:

Do not separate cap style LP16 orifice from its adapter. Separating the assemblies breaks the seal and causes an LP gas leak.



WARNING:

Do not use compressed air to clean a jeweled type orifice. The air pressure may dislodge the orifice from the adapter.



CAUTION:

Do not install cap style LP16 orifice in a burner that uses a jeweled type orifice or vice versa. The orifice adapter's threads are not compatible. Each orifice must be matched to its burner.



Figure 12. Burner.

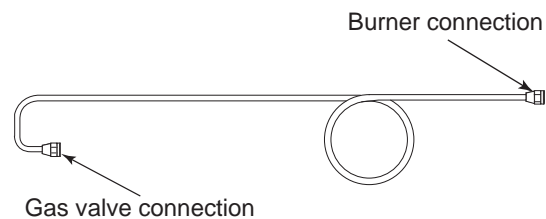

Figure 13. Burner tube.

Burner

The burner, see Figure 12, provides primary air access and acts as the fuel mixing chamber to support ignition and the combustion of propane gas. Primary combustion air flows into the burner through three circular openings. Any obstruction blocking any of the three openings will have an effect on the fuel/air mixture. Insufficient combustion air will cause carbon deposits to clog the burner slots. Carbon clogged burner slots along with heavy dirt deposits in the burner are the main cause of no cooling or poor cooling performance when the refrigerator is operating in LP gas mode.

Burner Tube

The burner tube is 1/4 inch OD aluminum tubing with an anti-vibration loop and a double flare at each end. See Figure 13.

Flue

The flue on all N6XX/N8XX terminates a few inches above the canister. See Figure 14. The flue comes equipped with a removable baffle ("spiral baffle") and a metal heat deflector.

The flue and its components should be checked annually. In roof exhaust venting applications, the refrigerator must be removed from the enclosure to check or service the flue or any of its components.

In most sidewall exhaust venting applications, removal of the side wall exhaust vent provides clear access to service the flue or any of its components.

A one inch diameter, loop-handle, twisted wire brush with a 27 inch wire handle is recommended for sweeping clean the flue.

Heat Deflector

The heat deflector, see Figure 14, deflects hot exhaust gases to the sides. It also keeps dirt and debris from getting into the flue. Cooling performance may be affected if the heat deflector is not installed or is not installed correctly.

Spiral Baffle

The spiral baffle, see Figure 14, traps and transfers heat to the cooling unit generator.

A retaining wire suspends the spiral baffle in the flue just above the flame. See Figure 15. The spiral baffle should be checked annually. To remove the spiral baffle from the flue:

1. Remove the heat deflector.
2. Unclip the baffle retaining wire from the rim of the flue.
3. Pull the baffle out of the flue tube.



CAUTION:

Do not cut or modify the spiral baffle retaining wire! The wire positions the baffle for optimal heat transfer.

Flame Appearance

The flame should be light blue with sharp blue root cones and a steady burning flame plume. See Figure 16.

A flame that is mostly orange or yellow, is erratic, and unstable, indicates a "dirty" burner. Burner cleaning procedures appear on page 32.

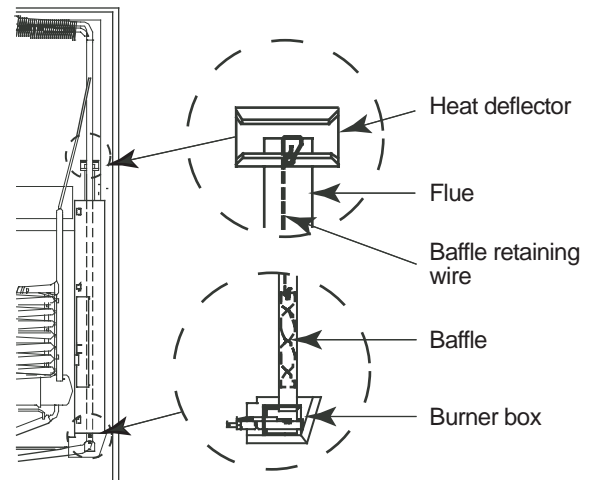

Figure 14. Flue and Components.

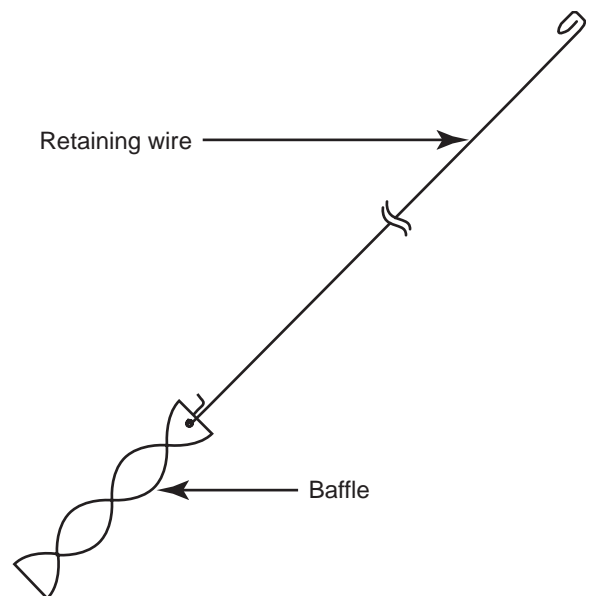

Figure 15. Flue Baffle.

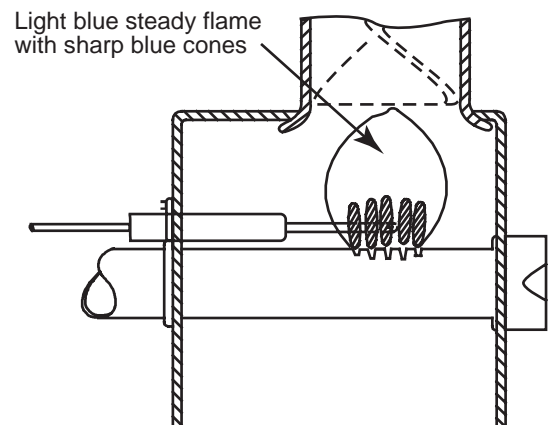

Figure 16. Flame Appearance.

Burner Cleaning Procedure



WARNING:

Burn hazard! Allow the burner box and burner components to cool before attempting to service the burner assembly or components.

1. Turn OFF power to the refrigerator.
2. Close the LP gas tank valve.

Step 3 through Step 5, refer to Figure 17, page 33

3. Close the combination gas control valve manual shut-off.
4. Remove the drip cup.



CAUTION:

To prevent damage to connections, piping, and components, always use two wrenches to loosen the burner tube. A damaged burner tube creates a potential for gas leaks.

5. Remove the burner box cover.

Step 6 through Step 8, refer to Figure 18, page 33

6. Disconnect the burner tube from the orifice assembly.
7. Remove the orifice assembly from the burner.
8. Remove the burner retaining screw.
9. Remove the burner from the burner box frame.
10. Clean the burner.

NOTE

The burner slots may be cleaned with a small flat file. The inner bore of the burner body may be cleaned with a 3/16 in., double-spiral wire brush. Do not damage the threads when cleaning the inner bore of the burner.

NOTE

Do not insert any type of cleaning tool or wire into the orifice. Do not drill or ream the orifice opening to clean it. Insertion of any type of cleaning tools, reaming, or drills through the opening will alter the volume of LP gas flow to the burner and create a fire hazard potential.



CAUTION:

Do not use compressed air to clean a jeweled type orifice. The air pressure may unseat the jewel orifice insert from the adapter.

11. Visually inspect the orifice. If dirty, wash the assembly with alcohol then allow to air dry. Replace the orifice assembly if the cleaning fails to remove dirt or if the condition of the orifice assembly is questionable.
12. Clean any accumulation of dirt or debris from the burner box base.
13. Reinstall the burner. Do not over tighten the burner's retaining screw.



CAUTION:

To avoid gas leaks and prevent damage to connections, piping, and components, always use two wrenches to tighten the burner tube. A damaged burner tube creates a potential for gas leaks.

14. Install the orifice assembly. First thread the orifice assembly into the burner finger tight, then finish tightening using two wrenches.
15. Connect the burner tube. First thread the fitting finger tight, then finish tightening using two wrenches.
16. Install the burner box cover. Do not overtighten the cover retaining screw.
17. Open the LP gas tank valve.
18. Open the solenoid gas valve manual shut-off.
19. Turn ON the refrigerator and select LP manual mode operation.
20. Leak test LP gas connections during the 30 second trial-for-ignition.



WARNING:

Do not attempt to repair LP gas leaks with the refrigerator in operation. Before attempting to repair a gas leak:

- Turn OFF the refrigerator.
- Close the LP gas valve and the solenoid gas valve manual shut-off.

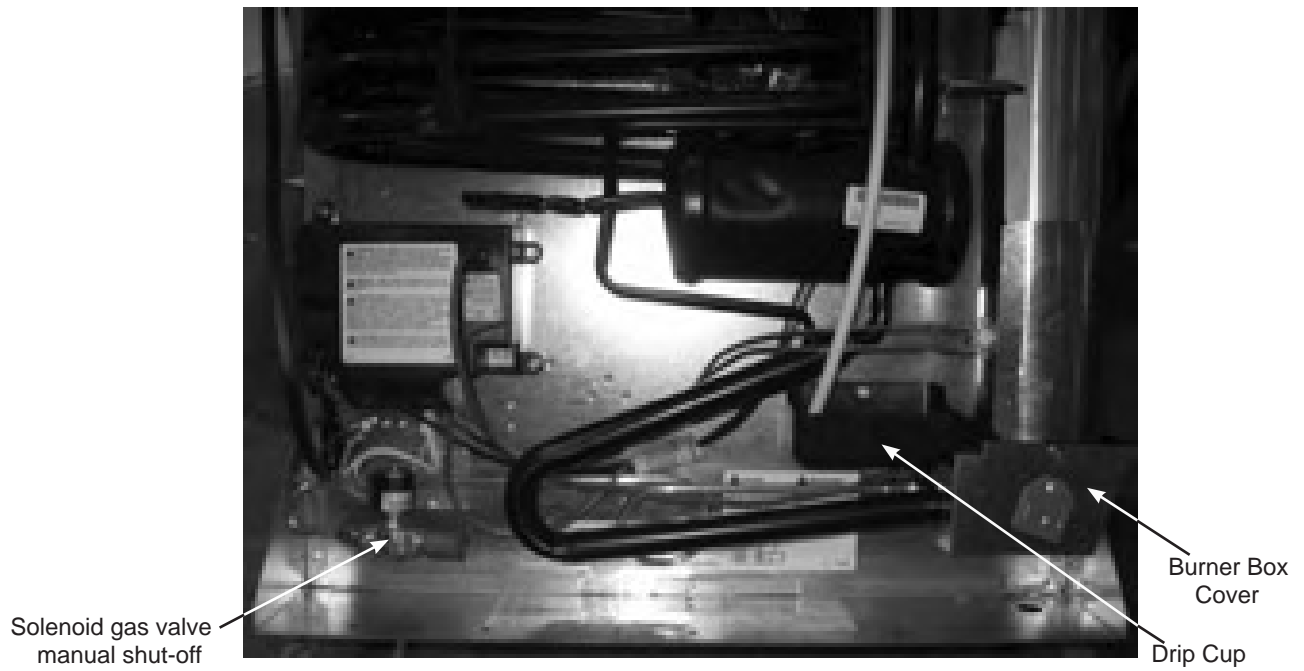

Figure 17A. Drip Cup and Burner Box Cover (Serial no. 9056492 and higher).

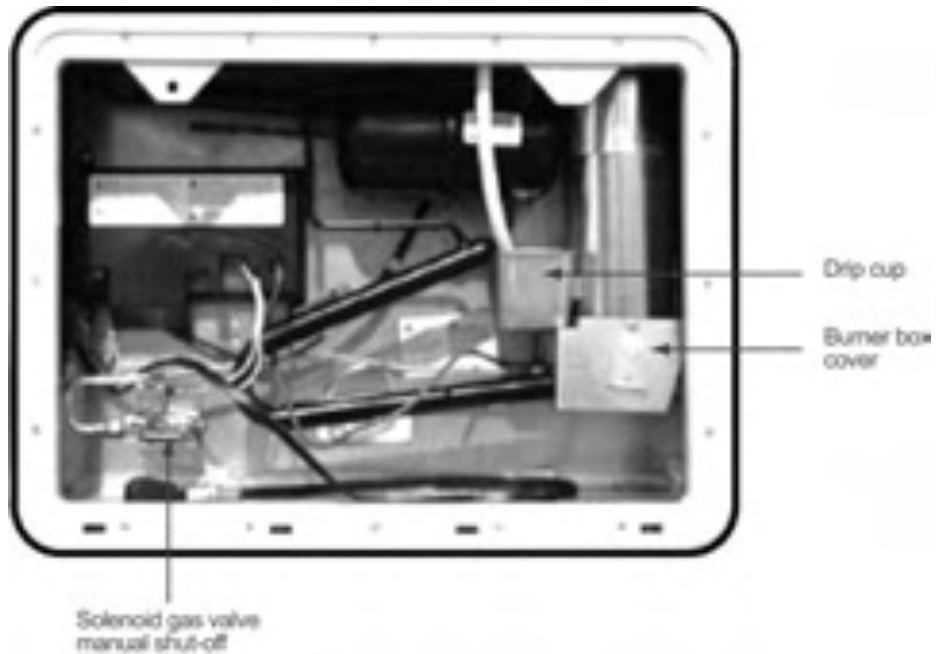

Figure 17B. Drip Cup and Burner Box Cover (Serial no. 9056491 and lower).

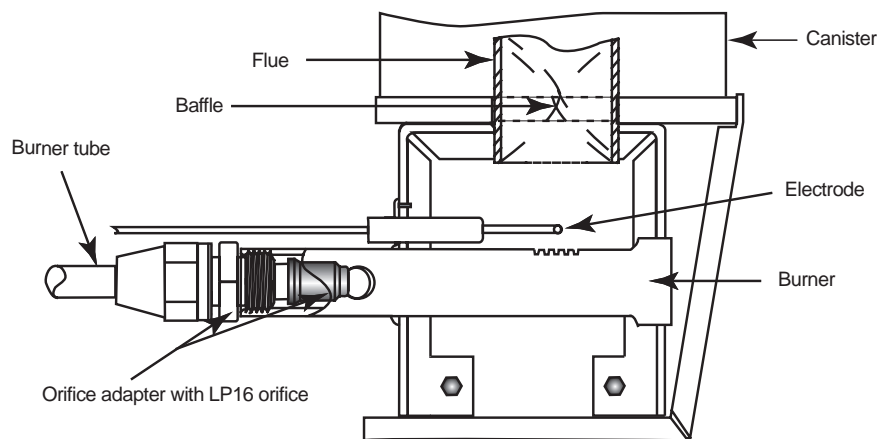

Figure 18. Burner and Components.

DC Voltage Requirements and Polarity

Operating controls require 10.5 to 15.4 Vdc to operate. The positive wire lead (+) connects to power board terminal **12VDC**; the negative wire lead (-) connects to terminal **GND**.

Power Board DC Fuse



WARNING:

Never replace a fuse with a higher amp rated fuse. Always use the specified fuse.

The controls circuit fuse is a standard 5 amp (tan color) automotive blade type fuse. It is located on the power board, terminal **F1**.

DC Power Wiring Requirements



WARNING:

Never use undersized wires to supply DC power to the power board. The use of undersized wires can cause low voltage and high amp draw conditions. The high amp draw caused by a circuit using undersized wires will cause the wire to overheat and creates an electrical fire hazard.

2-Way Models

18 AWG is the minimum AWG size wire that can be used for connecting DC power to 2-way models. The inline fuse for overload protection must not exceed 6 amps.

3-Way Models

The distance between the RV DC power source and the power board DC power connection terminals dictates the AWG size wire that must be used. If the distance from the DC power source is:

- 20 feet or less – 10 AWG or a larger gauge wire must be used. The size fuse for circuit overload protection must not exceed 30 amps.
- Over 20 feet – AWG 8 or a larger wire gauge must be used. The size fuse for circuit overload protection must not exceed 40 amps.

AC/DC Converter as Power Source

The power board must be supplied 12 Vdc only from the filtered output (battery side) of a converter.

Unfiltered voltage (commonly referred to as AC ripple) output of AC/DC converters can cause the electronic controls to set false fault codes. It can also turn off the refrigerator or prevent the refrigerator from turning off.

DC Heater—3-Way Refrigerators Only



WARNING:

Do not wire the heater(s) direct! Wiring heater(s) direct bypasses control safety devices and creates the potential for an electrical fire.

The DC heater, shown in Figure 19, is a cartridge type heater. The DC heater is rated for 225 Watts (16 amps, at a nominal 14 Vdc). Heater resistance should be between 0.82 and 0.91 ohms.

NOTE

The AUTO DC and DC-Manual Mode operation maintain refrigeration only.

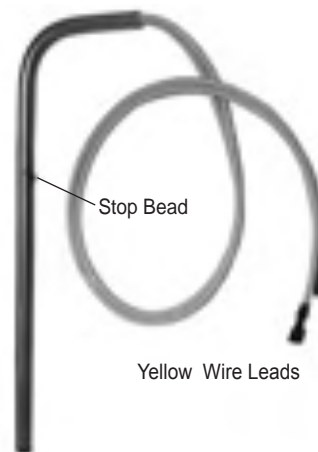

Figure 19. DC Heater

When AUTO DC or DC-Manual Mode does not maintain refrigeration and ventilation is correct:

- Measure DC voltage input to the power board.
- Measure the heater's amp draw.
- If amp draw is not as specified, measure the heater's resistance at ambient temperature.

The DC heater must be inserted into the heater tube until the stop bead makes full contact with the tube's rim. See Figure 20, page 35.

DC Heater Circuit Fuse



WARNING:

Never replace a fuse with a higher amp rated fuse. Always use the specified fuse.

The DC heater circuit fuse is a standard 30 amp (green) automotive blade type fuse. It is located on the DC board, terminal **F1**.

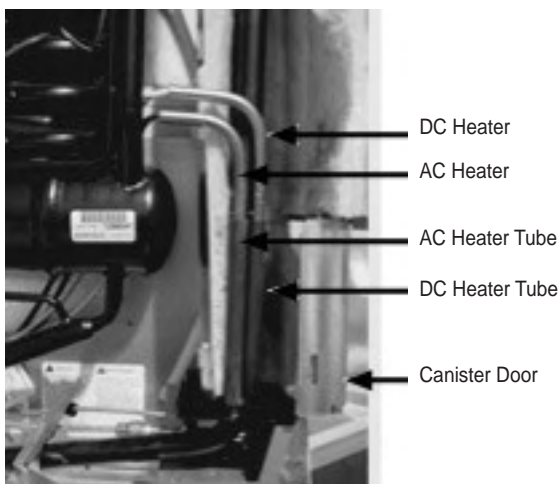

Figure 20. AC and DC Heaters (3-way refrigerator)

Lamp Assembly

The operation of the fresh food compartment 12 Vdc lamp is controlled by a magnet activated reed switch. The switch is in the optical control circuit board and the magnet is permanently mounted on the underside of the door's top trim piece.

Leaving the door ajar or open for more than two minutes causes the controls to display a "d" or "dr" fault code (depending on unit model). Closing the door turns off the light and clears the "d" or "dr" fault indicator from the display. However, the fault code will be stored in the diagnostic mode nonvolatile memory. For "d"/"dr" troubleshooting procedures. See page 19. As shown in Figure 21, the light assembly harness and thermistor share the same connector. Remove the light cover to access the connector.

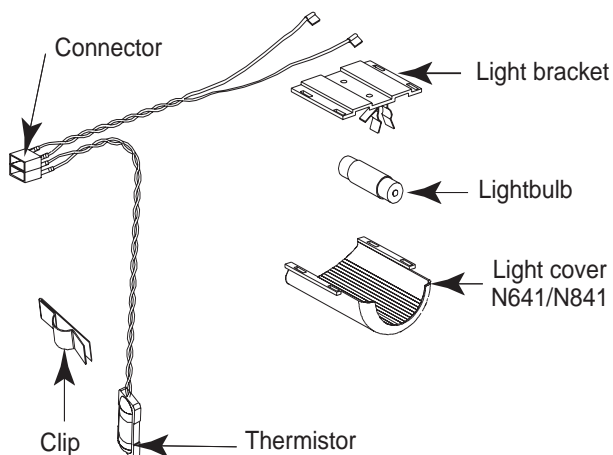

Figure 21. Lamp/Thermistor Assembly.

Divider Heater

The divider heater is permanently "foamed" between the divider separating the freezer and fresh food compartment. The controls constantly monitor power board voltage output to the heater through built in diagnostics. Turning the refrigerator on automatically powers the heater.

AC Power Requirements



WARNING:

Electric shock hazard! The refrigerator is fed power from more than one source. Unplug the AC cord from the RV AC receptacle before servicing electrical or electronic components.

AUTO AC and AC-Manual Mode operation requires 108 to 132 Vac. AC power must be supplied through a 2 pole/3 wire/20 amp grounding type receptacle.

AC Heater



WARNING:

Do not wire the heater(s) direct! Wiring heater(s) direct bypasses control safety devices and creates the potential for an electrical fire.

The AC heater, see Figure 22, is a cartridge type heater. Refrigerators with a serial number lower than 854647 have a heater rated for 300 Watts (2.7 amps @ 110 Vac) with a heater resistance of 41 ohms. Refrigerators with a serial number 854647 and higher have a heater for rated 300 Watts (2.5 amps at 120 Vac) with a heater resistance of 48 ohms.



Figure 22. AC Heater.

When poor or no cooling in AUTO AC or AC-Manual Mode, operation is present:

1. Measure AC voltage input to the power board.
2. Measure heater amp draw.
3. If amp draw is not as specified, measure the heater's resistance at ambient temperature.

When replacing an AC heater make sure the stop bead rests fully against heater tube rim. See Figure 22.

AC Heater Circuit Fuse

The AC circuit fuse is a fast acting 8-amp 1/4" x 1 1/4" AGC type. It is on the power board, terminal F2.

AC Power Cord

The AC power cord shown in Figure 23(a) is used on units without ice maker. On all AC power cords the round side of the plug that connects to the power board faces the left side of the power board. The cord's grounding prong on the AC outlet connector must be left intact and never be modified or cut. The cord's ground wire (green wire) must always be fastened to the refrigerator cabinet metal plate.

Power Cord for Ice Maker Units

The AC power cord shown in Figure 23(b) is used on N64X IM and N84X IM units (IM = ice maker). The cord has two short wire leads originating at the rear of the power board connector plug to connect the ice maker wire harness black and white leads. The smooth wire is the (hot) line voltage lead; it has a male quick-connect type terminal. The ribbed wire is the neutral lead and has a female quick-connect type terminal. Refer to pages 75 and 76 for ice maker wiring pictorials and diagrams.

All N643IM and N843IM units are equipped with an independent AC power cord (white in color) to supply 120 Vac to the ice maker only.

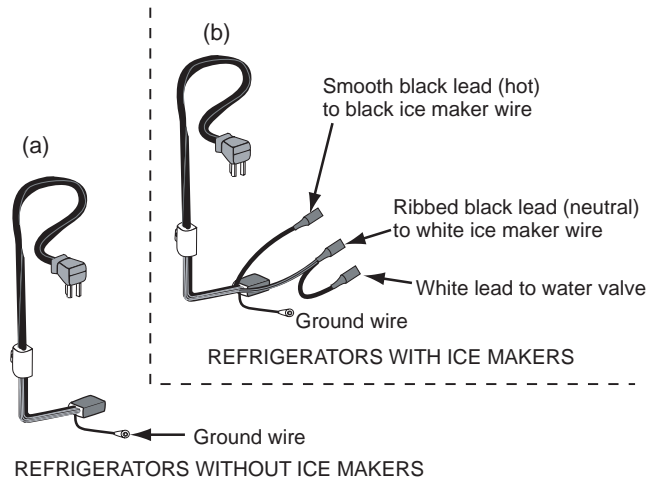

Figure 23. AC Power Cord.

12 Vdc Ventilation Fan

The 12 Vdc ventilation fan, shown in Figure 24, enhances ventilation in sidewall venting installations (unit installed in RV slide out enclosures). The letter "F" in a model number is used to identify refrigerators with a factory installed 12 Vdc ventilation fan. All sidewall vented units must be equipped with a ventilation fan to prevent combustion gases and hot ventilation air from stagnating in the enclosure.

Ventilation fans are supplied 12 Vdc through power board connections. Fan operation is automatically controlled by a thermostatic switch mounted on the condenser fin. **For models with the S/N 10086691 or lower, thermostat will be on the first fin from the right (boiler) side. For models with the S/N 10086692 or higher (or replacement cooling units), thermostat will be on the first fin from the left.** See Figure 25. The switch turns the fan on when the temperature on the first condenser fin is approximately 130 °F. The switch turns the fan off when fin temperature falls to approximately 115 °F.

NORCOLD® fan kit is wired to the power board 12 Vdc connections using "Y" type wire connector. The fan circuit is protected by an in-line fuse (included in the kit). The fuse, part of the fan kit wiring is a fast acting 1 amp, 1/4" x 1 1/4" AGC type. See Figure 26. The wiring pictorial for field installed fan is shown in Figure 27, page 37.

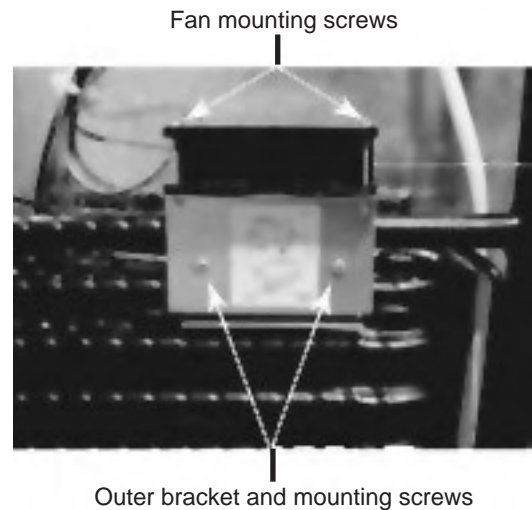

Figure 24. Fan Mounted on Top of Absorber Coil.

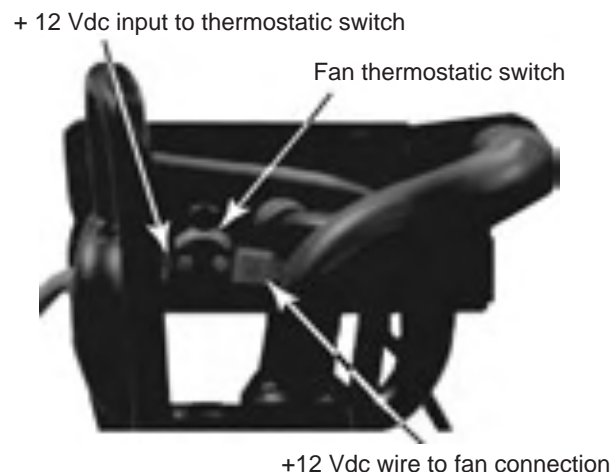

Figure 25. Fan Thermostat.

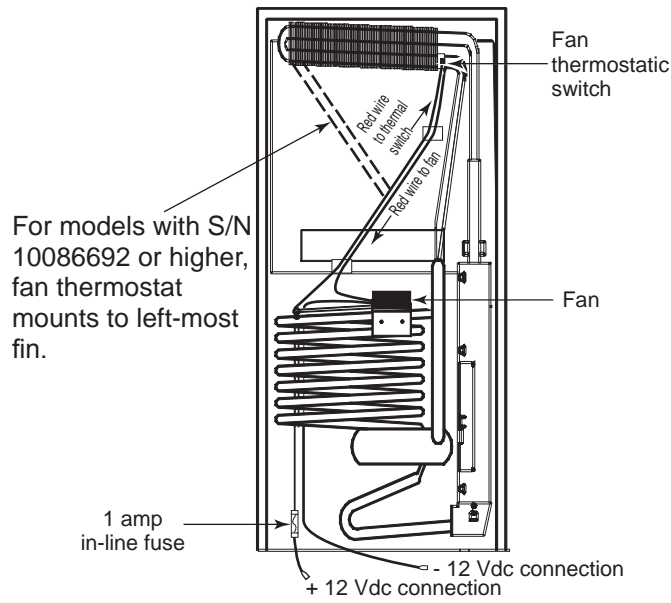

Figure 26. Fan with Wiring Arrangement for Field Installed NORCOLD Fan Kit.

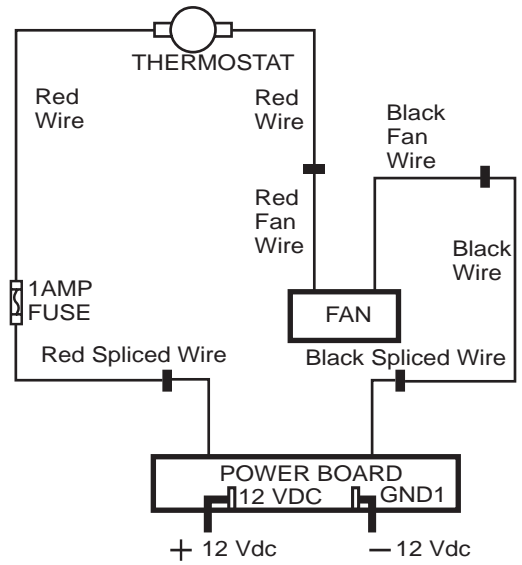

Figure 27. NORCOLD Fan Kit Wiring Pictorial.

COOLING UNIT

Description

The cooling unit is a self-contained gravity flow absorption refrigeration system. The refrigerant charge is a solution of water, ammonia, sodium hydroxide, and sodium chromate (a corrosion inhibitor). Refrigeration is accomplished by applying heat energy and venting the heat extracted from the freezer and fresh food cabinet while maintaining the unit leveled.

Heat Absorption

The refrigerant transfers the heat from the freezer and the food cabinet to the absorber coils. At the absorber coils the metal surface absorbs the heat and air flow over the external surfaces of the coils and carries away the heat. A thermal air current created by the rising hot air flows out of the enclosure through the roof exhaust vent or sidewall exhaust vent (depending on installation). The flowing air mass passes over the surface of the condenser fins where it absorbs heat transferred from the ammonia vapors flowing through the condenser.

The thermal airflow process creates a "chimney effect". The "chimney effect" creates a continuous draft of cooling and combustion air. The fresh air drafted by the "chimney effect" through the intake vent removes rejected heat, support combustion, and expels the exhaust gases produced by the combustion process. Obstructions, restrictions, or modifications to vents or the enclosure will affect the heat absorption cycle. Poor cooling unit performance may be due to:

- Loose insulation interfering with the ventilation process.
- Construction material or debris left in the enclosure.
- Insect screen covering vents.
- Plastic sheeting covering vents.
- Items stored in the enclosure.
- Modifications to vents or enclosure.
- No roof or sidewall exhaust vent opening.

Information pertaining to ventilation and enclosure requirements begins on page 23.

Leveled Operation

The circulation of the refrigerant through the cooling unit is accomplished by gravity flow; therefore, the refrigerator must be operated leveled. Off-level operation affects the flow of the refrigerant through the cooling system. The maximum off-level operation limits are:

- 3 degrees from side-to-side.
- 6 degrees from front-to-back.

Exceeding the maximum off-level limits can permanently damage the cooling unit.

The cooling unit or its performance are not affected when the vehicle is in motion

Gradual Decrease in Cooling Efficiency

A gradual decrease in cooling efficiency is not a clear indication of cooling system failure. Other factors that affect cooling efficiency include ventilation, the heat input, off-level operation, lack of service and maintenance, inadequate repairs, or unauthorized field modifications. If any of these factors exist and are not corrected, a replacement cooling unit will also perform inefficiently or fail.

Step-by-step troubleshooting is the best approach when dealing with a gradual decrease in cooling. It is important to consider that, though not efficiently, the cooling unit is working.

Troubleshooting should always begin by checking ventilation, then thoroughly checking the cooling unit, and heat sources. In the majority of reported case, the problem has been related to the installation, which in turn hindered cooling unit ventilation.

Additionally, ambient air temperature plays a significant role if the unit was not installed correctly. Incorrect installation lead to poor ventilation, which in turn relates to poor cooling performance.

The unit's service and maintenance history should be considered when checking a cooling unit for poor cooling performance. The service history and the scope of service work performed may lead directly to cause and resolution of a cooling problem.

The cooling unit has to reach normal operating temperatures before troubleshooting can take place. It takes an average of four hours for the refrigerant to reach normal operating temperatures. The time frame to reach operating temperatures depends on ambient air temperature.

Cooling System Monitoring

Software Monitoring

Certain controls use software to monitor cooling system performance during cooling cycles. If the control senses that the system is not cooling, it displays a fault code ("n"/"no" "co") and locks out all heat energy sources.

First "No Cooling" Fault Occurrence

Users can reset the controls by turning the refrigerator off then back on. The user resetting option can only be accomplished when the controls record the first "no cooling" ("n"/"no" "co") fault occurrence. The completion of a full cooling cycle will remove the recorded first "n"/"no" "co" fault from memory and returns the controls to normal monitoring operation.

Two Recorded "No Cooling" Fault Occurrences

If the controls detect two consecutive recorded "no cooling" faults, the "n"/"no" "co" fault code displays and the controls will lock out all heat sources (AC/LP/DC). The power board can then only be reset by an authorized service center after troubleshooting and testing cooling system operation. See Page 21.

Hardware Monitoring

Later model cooling systems are equipped with a High Temperature Performance Monitoring system. If an abnormally high cooling system temperature is encountered, a thermal switch (mounted on the insulation canister just above the burner box) opens and all energy sources are disabled. The customer is notified of the condition via the control display. The thermal switch may be reset by depressing the red pushbutton located between the two terminals on the back of the switch. When successfully reset, the resistance between the two terminals will be less than 1 ohm.

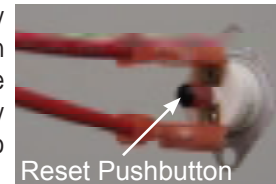

WARNING:

The thermal switch is not intended to be reset more than once. Multiple trips of thermal switch may indicate a more serious overtemperature condition inside the cooling system and must be handled by an authorized Norcold Service technician.

Troubleshooting Cooling Faults

A high percentage of cooling units returned labeled “faulty” are fully operational units. The flowchart on page 38 provides information to troubleshoot cooling unit related faults.

Poor or No Cooling on AC Mode



Do not work on live circuits! Turn off and disconnect AC power and DC power supplies before attempting to remove, service, or repair any of the refrigerator's electrical or electronic circuits or components.

When troubleshooting poor or no cooling in AUTO AC or AC-Manual Mode, first check AC voltage input to the power board, then check voltage output to the heater, and the heater's amperage draw.

AC voltage problems, high or low voltages, can be caused by the RV AC power supply circuit. To troubleshoot AC faults, refer to the diagnostic flow charts on pages 16, 17, and 18 of this manual.

Poor or No Cooling on LP Gas Mode



LP gas (propane) is highly flammable and explosive! Do not smoke, light fires, or create sparks when working on the LP gas system.

Do not use an open flame to leak test any propane gas system component.

When troubleshooting poor or no cooling in AUTO LP mode or LP-Manual Mode, always check the burner flame appearance first. Most faults on LP gas operation related to a "dirty burner."

The diagnostic flowchart on page 12 of this manual provides information to troubleshoot the no flame faults.

Poor or No Cooling on DC Mode – 3-Way Models



Do not work on live circuits! Turn off AC power and DC power before attempting to remove, service, or repair any of the refrigerator's electrical or electronic circuits or components.

When troubleshooting poor or no cooling in AUTO DC or DC-Manual Mode, always check DC voltage input to the power board, voltage output to the heater, and heater amperage draw. If DC voltage input to the refrigerator is lower than 12 Vdc, the problem is usually related to the DC power supply source. The RV DC power supply source may not be supplying the correct voltage to the power board.

The diagnostic flowcharts on pages 13, 14, and 15 of this manual provide information to troubleshoot DC power faults.



Do not operate the refrigerator if the cooling unit is leaking or leakage is suspected.

Refrigerant Leakage

Yellow powder or liquid deposits at the rear of the refrigerator or ammonia smell inside the refrigerator indicate refrigerant leakage. Exercise extreme care when handling a leaking or a suspected leaking cooling unit. The cooling system refrigerant solution consists of water, ammonia, sodium hydroxide, and sodium chromate.

Disposal of Cooling Unit

Dispose of cooling unit according to local, state, and federal guidelines and regulations. Dispose of any liquid waste or residue, according to pre-emergency planning and all applicable local, state, and federal regulations.

Do not, under any circumstances, release any waste or residue directly into sewers, or surface waters. If any liquid leaks or spills from the cooling unit, contact the nearest environmental services for guidance.

Cooling System Diagnostic Flowchart



WARNING:

Do not bypass or modify the refrigerator's controls or components to diagnose the cooling system. Do not wire the heater(s) direct. The heater is supplied power through a fused circuit.



WARNING:

Do not operate the refrigerator if the cooling unit is leaking or a leak is suspected.

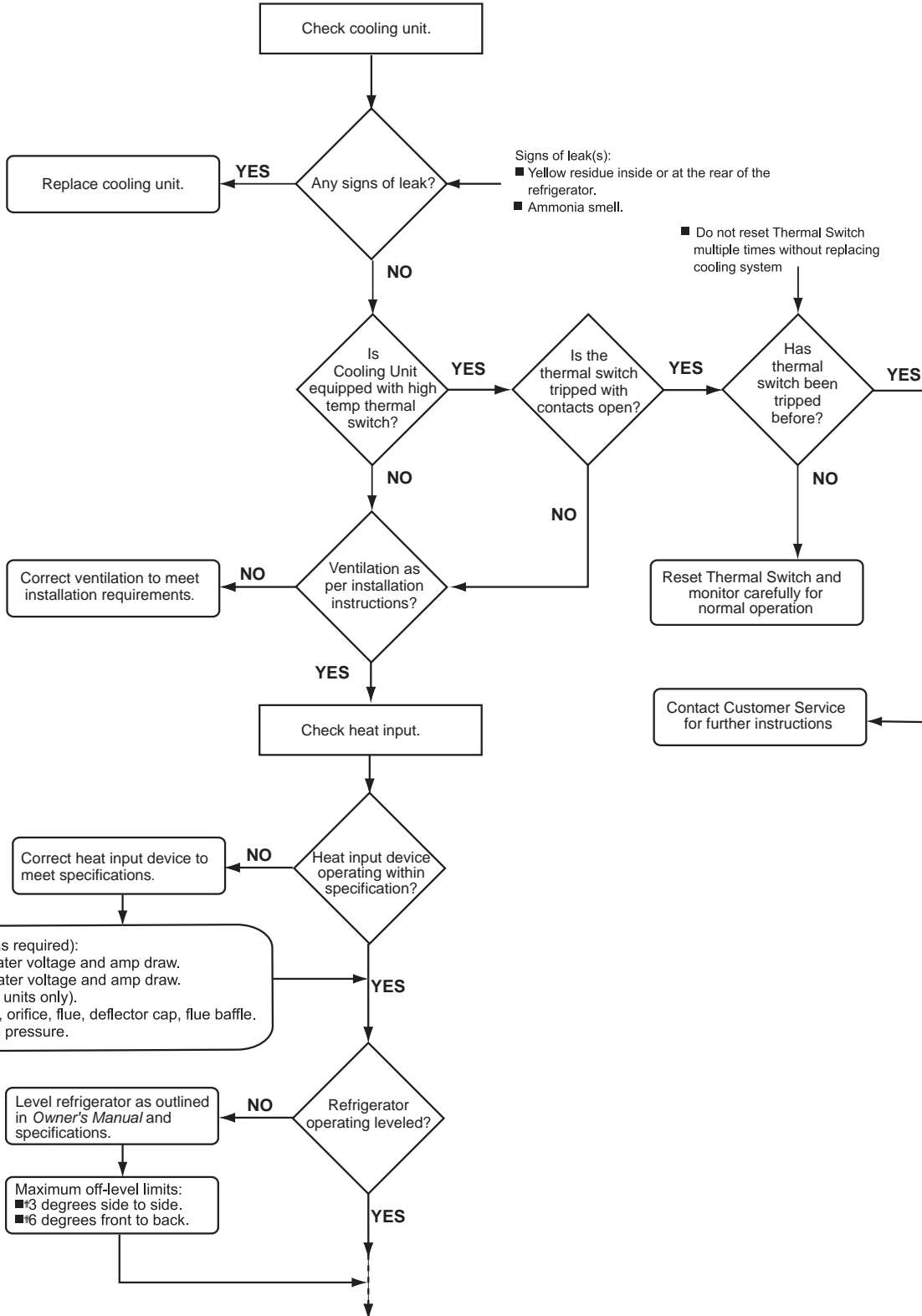

Continued on page 41.





WARNING:

Do not operate the refrigerator if the cooling unit is leaking or a leak is suspected.

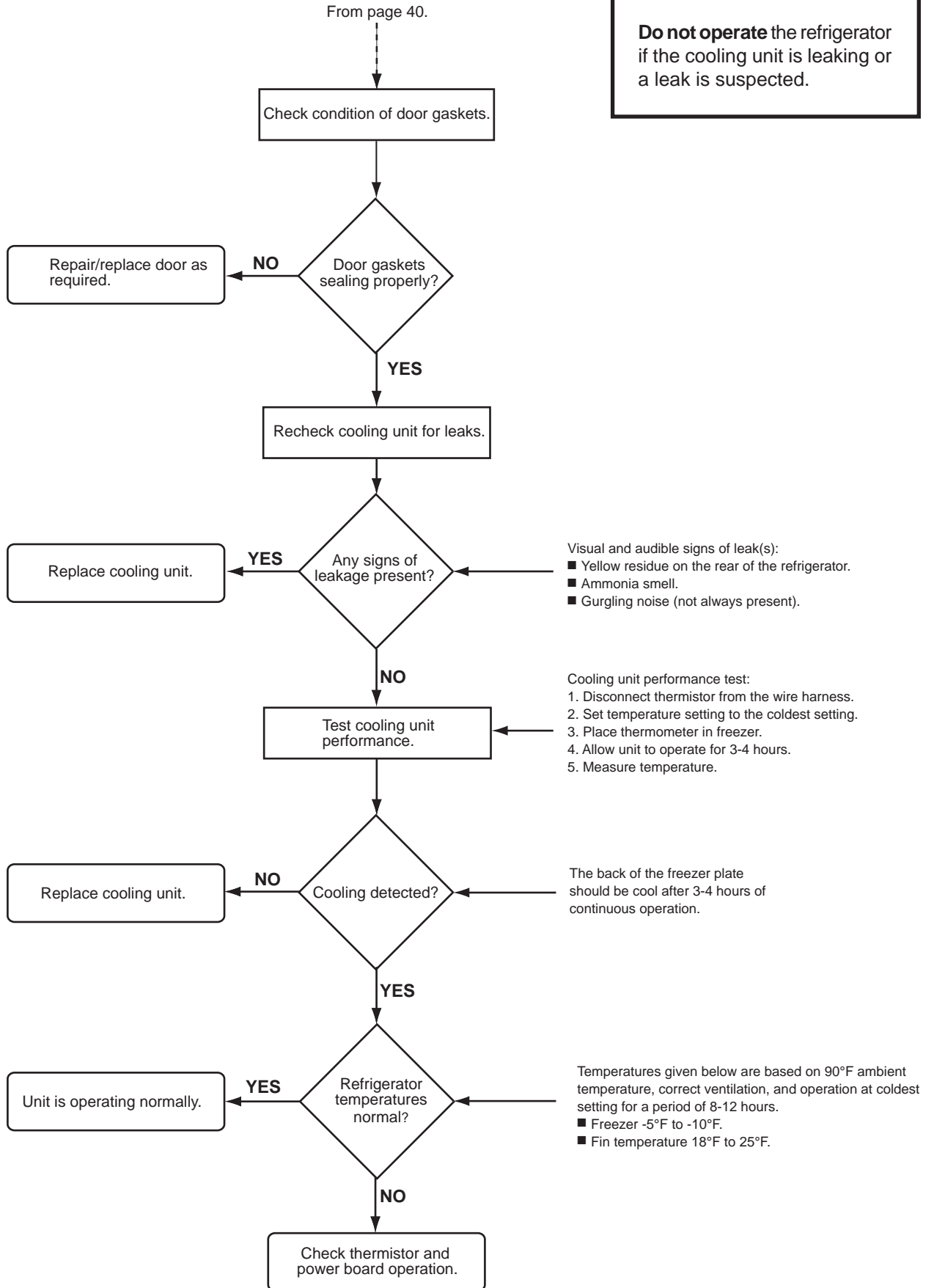

Replacing the Cooling Unit

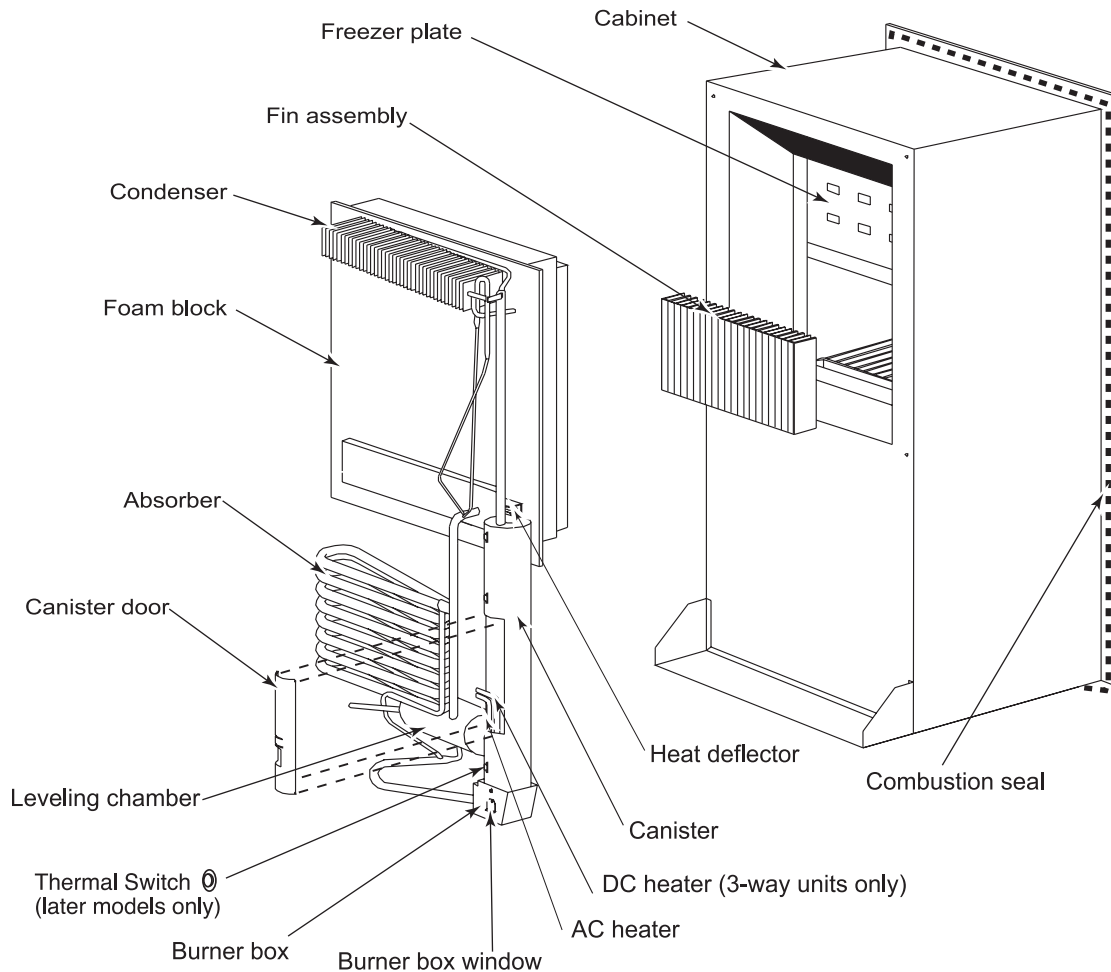

Figure 28. Cooling Unit and Components.

NOTE

This procedure supplements the instructions packaged with N6XX/N8XX models replacement cooling units. Follow the procedure thoroughly to install the cooling unit correctly. Incorrect installation, adjustments, or modifications will affect cooling performance.

5. Disconnect the RV LP gas supply line from the gas valve.

N64XIM/N84XIM (ice maker)

- a. Close the water supply valve to the ice maker.
 - b. Disconnect the RV water supply line from the ice maker water valve.
6. Remove two retaining screws from the bottom trim piece, then remove trim piece. See Figure 31, page 45.
 7. Remove two retaining screws from the bottom of the cabinet. See Figure 31, page 45.
 8. Remove two hole plugs from the top trim. See Figure 32, page 45.
 9. Remove two top cabinet retaining screws. See Figure 32, page 45.

Removing the Refrigerator from the Enclosure

Refer to Figure 28 to locate components.

1. Close the LP gas tank valve(s).
2. Disconnect the AC power cord from the RV receptacle.
3. Turn OFF RV DC power to the refrigerator.
4. Disconnect the DC power supply wires from the power board.

Removal of Cooling Unit

N64XIM/N84XIM (ice maker)

- a. Remove the ice maker water line.
- b. Disconnect the ice maker wire harness wires (white and brown wires) from the water valve solenoid.
- c. Disconnect the ice maker wire harness ground wire.
- d. Move the wire harness out of the way.
- e. Remove the water valve.

N62XF/N82XF/N64XF/N84XF (fan models)

- Remove the fan, bracket, thermostat, and wiring from the cooling unit.

1. Remove the drip cup retaining screw, then remove the cup.
2. Remove the burner box cover retaining screw, then remove the cover.
3. Disconnect the burner tube from the gas valve at the gas valve.
4. Remove the burner retaining screw.
5. Remove the burner tube and burner from the burner box.
6. Disconnect the gas valve wires from the power board.
7. Remove the gas valve assembly (including bracket).
8. Loosen the spark/sense electrode assembly retaining screw and remove the assembly from the burner box.
10. Remove the rear mounting flange screws.
11. Pull the refrigerator from the enclosure.
12. Remove the burner box retaining screws, then remove the burner box.

3-way refrigerators (AC/LP/DC)

- Disconnect the DC heater wire leads from power board terminals FLP/DC HEAT and DC_HT GND.

13. Disconnect the AC power cord from the power board.
14. Remove the power board cover retaining screws, then remove the cover.
15. Disconnect the AC heater wires from power board terminals AC_HT -LO1 and AC_HT_HI.

3-way refrigerators (AC/LP/DC)

- Remove DC heater (3-way models only). Retain the heater for reinstallation.

16. Remove the thermistor from the 10th fin.
17. Remove eight retaining screws along with washers from the freezer plate.
18. Remove four retaining screws from the fin assembly.

19. Cut or remove the tape around the edge of the foam plug.
20. Remove two absorber bracket retaining screws.
21. Remove the condenser retaining screw. See Figure 29, page 44.
22. Separate the cooling unit from the refrigerator cabinet. To separate:
 - a. Grab the cooling unit by the liquid heat exchanger.
 - b. Pull cooling unit upward at a slight angle to unseat the foam plug.
23. Pull the cooling unit from the cabinet.

Installation of Replacement Cooling Unit

NOTE

The sealant must be applied correctly to prevent air from being drawn into the cooling unit's high and low evaporators.

1. If the refrigerator is an icemaker model, carefully tear off the perforated square corner at the top of the metallic cardboard foamed onto the new system. This is necessary to clear icemaker connections on the back of the cabinet.
2. Clean the old sealant from the back of the evaporator plate, fin assembly, cooling unit, and the cabinet step.
3. Apply a 1/2 inch bead of sealant to the cooling unit low and the high temperature evaporators, and to the foam plug step. See Figure 30.
4. Mate the cooling unit foam plug section with the cabinet step opening. The foam plug must seat evenly against the cabinet step.
5. Fasten the condenser section to the cabinet. Do not overtighten the condenser retaining screw(s). Refer to one of the pictures under Figure 29 that matches you cabinet serial number for more details.
6. Fasten the freezer plate to the cooling unit (eight screws with washers). **Do not overtighten the freezer plate screws.**
7. Fasten the fin assembly to the cooling unit (four screws). **Do not overtighten fin screws.**
8. Attach the thermistor to the 10th fin (counting from right to left).
9. Fasten the absorber section of the cooling unit to the cabinet (two screws). **Do not overtighten retaining screws.**
10. Tape the edge of the foam plug to the cabinet. Use HVAC metallic tape or heavy duty duct tape.

N62XF/N82XF/N64XF/N84XF (Fan models)

- Reinstall the fan bracket, fan, thermostat, and wiring. See wiring diagram on the outer surface of the fan bracket or refer to Figure 27, page 37.

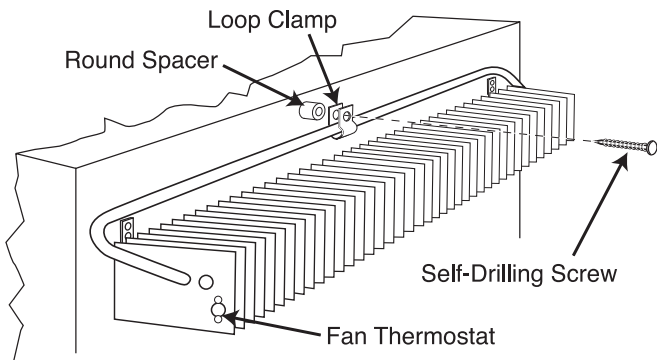

Figure 29A – For S/N or lower

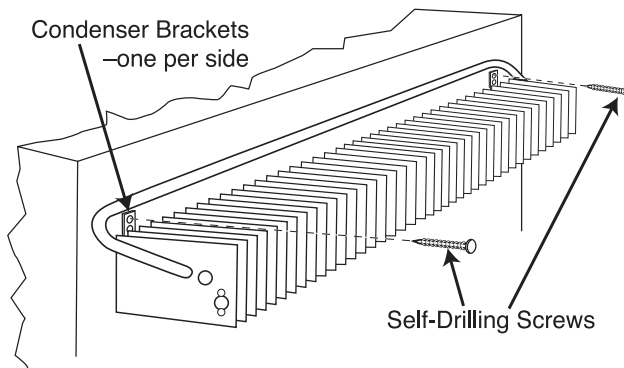

Figure 29B – For S/N or higher

- Use the included loop clamp, round spacer and self-drilling screw to secure the condenser to the cabinet. Do not use the brackets at each side of the condenser.
- The clamp and spacer are attached to the tube above the condenser as shown. Locate the clamp at the approximate center of the tube, but it may be necessary to slide it up on the tube in order to screw into a long, narrow nutplate built into the cabinet.
- Using a level, make sure the condenser is level before driving the screws. Although the old system may have had an angled condenser, the new system is meant to have the condenser mounted level.

- Use the two screw tabs at each side of the condenser.
- Using a level, make sure the condenser is level before driving the screws. Although the old system may have had an angled condenser, the new system is meant to have the condenser mounted level.

N64XIM/N84XIM (ice maker)

- Reinstall the ice maker water valve.
 - Reconnect the ice maker water line.
 - Connect the brown and the white wires to the water valve solenoid terminals.
- Install the burner box.
 - Install the burner tube and burner assembly. Do not overtighten fittings.
 - Install the gas valve and connect the burner tube to the valve. Do not overtighten fittings.
 - Install the spark/sense electrode assembly. Set electrode-to-burner air gap 1/8 to 3/16 inch.
 - Install the burner box cover.
 - Connect the AC heater wires to power board terminals AC_HT -LO1 and AC_HT_HI.

- Connect the gas valve wires to the power board terminals GV and GV_GND.
- Plug the AC cord into the power board.
- Connect the spark/sense electrode assembly to the power board.
- Attach the fan thermostat to the first condenser fin from the left (as looking at the back) using the screw holes provided

3-way refrigerators (AC/LP/DC)

- Install DC heater into tube.
 - Connect heater wires to terminals FLP_DC HEAT and DC_HT_GND.
- Reinstall the power board cover.

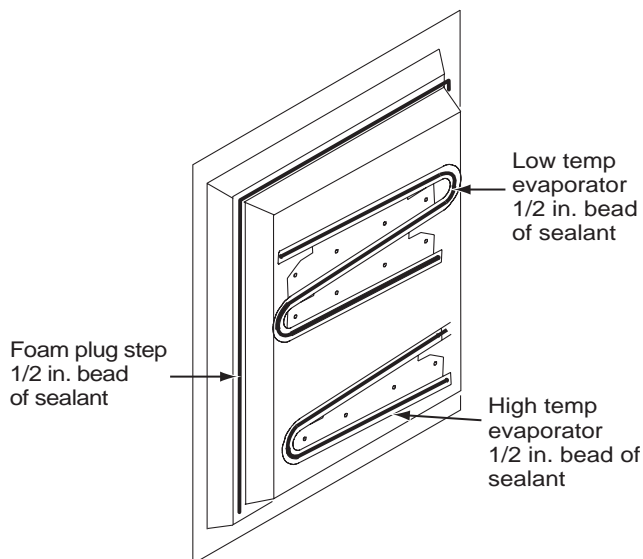

Figure 30. Application of Sealant.

Reinstallation of Refrigerator into Enclosure



Do not install the refrigerator if the combustion seal has been damaged. A damaged combustion seal must be replaced. The seal isolates the living area of the vehicle from exhaust gases generated by LP gas combustion. LP gas exhaust gases contain carbon monoxide, which is an odorless, colorless gas that can cause dizziness, nausea, or in extreme concentrations, death

1. Check the condition of the combustion seal. Replace seal if damaged. Do not install the refrigerator if the combustion seal is damaged.
2. Place the refrigerator in the enclosure. The combustion seal must seat fully against the enclosure wall.
3. Attach the bottom of the cabinet to the enclosure. See Figure 31.
4. Reinstall the bottom trim piece. See Figure 31.
5. Secure the top of the cabinet with two screws and install hole plugs. See Figure 32.
6. Secure the back of the cabinet to the enclosure floor with two screws.

N64XIM/N84XIM (ice maker)

- a. Connect the water supply line to the ice maker water valve.
 - b. Open the water supply to the ice maker.
7. Connect the RV LP gas supply line to the gas valve inlet fitting.
 8. Open the solenoid gas valve manual shut-off.
 9. Plug the refrigerator AC power cord to the RV receptacle.
 10. Connect the RV DC power supply wires to power board terminals 12VDC and 12V_GND1.
 11. Open the LP gas tank valve(s), then leak test LP gas connection at solenoid gas valve.
 12. Leak test the burner solenoid gas valve and orifice assembly burner tube connections.

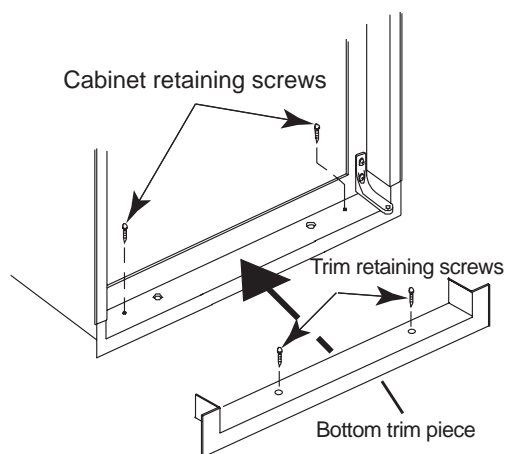

Figure 31. Bottom trim and retaining screws.

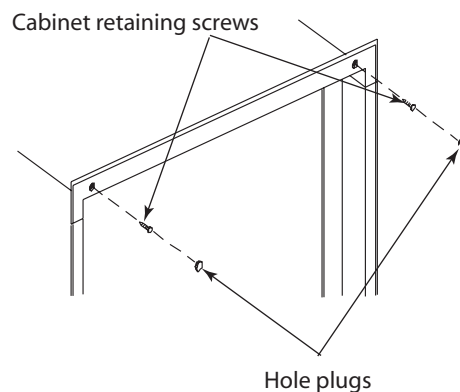

Figure 32. Top retaining screws and hole plugs.

Inputs, outputs, monitoring, and diagnostic functions are managed and controlled by the power board and optical control assembly. The wire harness interfacing the power board with the optical control assembly is "foamed" into the cabinet. Wiring pictorials and schematics can be found on pages 48-51.

Power Board

The power board is seated on an insulated base to prevent the printed circuit from making contact the refrigerator's cabinet metal plate.

Two, self-tapping 1/4 inch hex head screws hold the base in place. The power board cover is held by two self-tapping 1/4 inch hex head screws.

Early Versions of Power Boards

The power board can only be reset by jumpering pins on the power board on earlier controls of these refrigerators:

Model	Serial No.	Manufacture Date
N61/N81	Not applicable	Not applicable
N621/N821	9126824 and lower	Before 4/11/2006
N623/N823	8970880 and lower	Before 3/1/2006
N64/N84	9044283 and lower	Before 3/22/2006
N64.3/N84.3	8938727 and lower	Before 2/21/2006

Removal—Power Board

1. Turn OFF refrigerator.
2. Turn OFF RV DC power to the refrigerator.
3. Disconnect DC power supply wires from power board terminals 12 VDC and 12_VGND1.

3-way refrigerators (AC/LP/DC)

- Disconnect the DC heater wires from terminal FLP/ DC HEAT and DC_HT GND.
4. Unplug the AC power cord from the RV AC receptacle.
 5. Unplug the AC cord from the power board.
 6. Disconnect the gas valve wires from power board terminals GV and GV_GND.
 7. Disconnect the spark sense electrode wire.

N64XIM/N84XIM (ice maker)

- Loosen the water valve bracket, then move the bracket/water valve assembly out of the way.
8. Remove the three, 1/4 inch self-tapping hex head screws from the power board cover.
 9. Remove the power board cover.
 10. Disconnect the AC heater wires from power board terminals AC_HI and AC_LO.
 11. Disconnect the wire harness connector from power board, terminal P1.
 12. Remove two, 1/4" hex head screws, then remove the power board along with its base.

N61X/N81X Power board – S/N 9056491 or lower

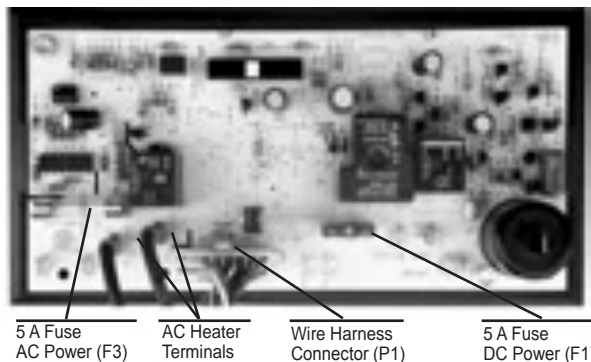

N621/N821: Power board – S/N 9126824 or lower N623/N823: Power board – S/N 8970881 or lower

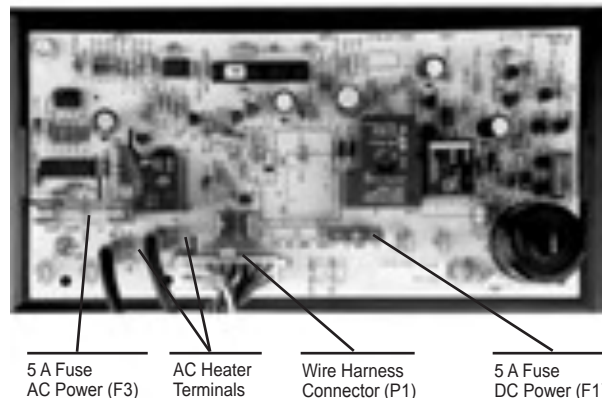

N641/N841: 2-Way Power board – S/N 9056491 or lower

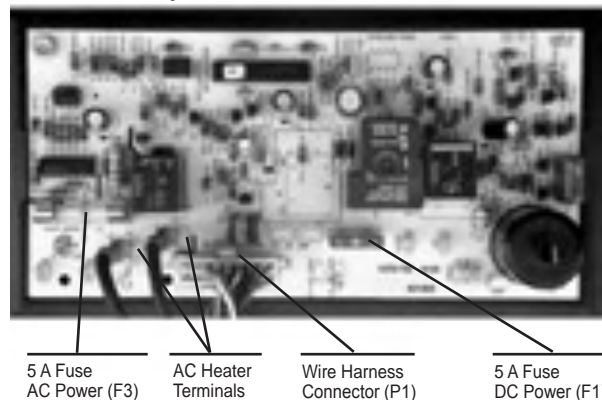

N641/N841: 3-Way Power board – S/N 9056491 or lower

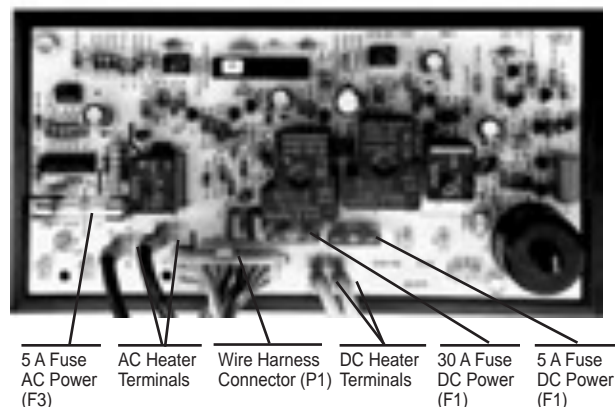

Installation—Power Board

1. Seat the power board in the base.
2. Attach the power board and base assembly to the refrigerator using two, 1/4 in. self-tapping hex head screws. **Do not overtighten screws.**
3. Connect the wire harness connector to the power board, terminal P1.
4. Connect the AC heater wires to terminals AC_HI and AC_LO.
5. Position and align the power board cover over the power board. Attach the cover using three, 1/4 in. self-tapping hex head screws. **Do not overtighten screws.**
6. Connect the solenoid gas valve wires to terminal GV and GV_GND.
7. Connect the spark/sense electrode wire to the power board high tension terminal.

3-way refrigerators (AC/LP/DC)

- Connect the DC heater wires to power board terminals FLP/DC HEAT and DC_HT GND.
8. Connect the AC power cord to the power board and plug the AC power cord into the RV AC receptacle.
 9. Connect positive and the negative DC power wire leads to the power board.
 - Positive wire (+) to terminal 12VDC.
 - Negative wire (-) to terminal 12_VGND1.

N64XIM/N84XIM (ice maker)

- Reinstall the water valve and bracket assembly.
10. Turn ON the RV DC power to the refrigerator.
 11. Plug the AC power cord into the refrigerator receptacle.
 12. Turn ON refrigerator, then check all power board control functions before placing in service.

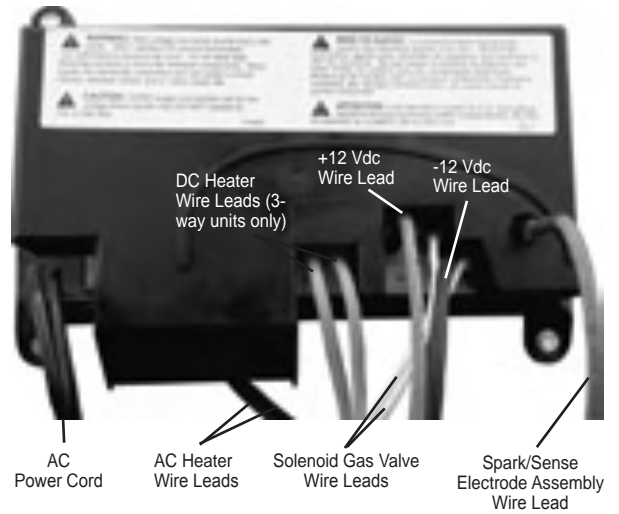

**Figure 34. Power Board, 3-Way with Cover
– S/N 8938727 or lower**

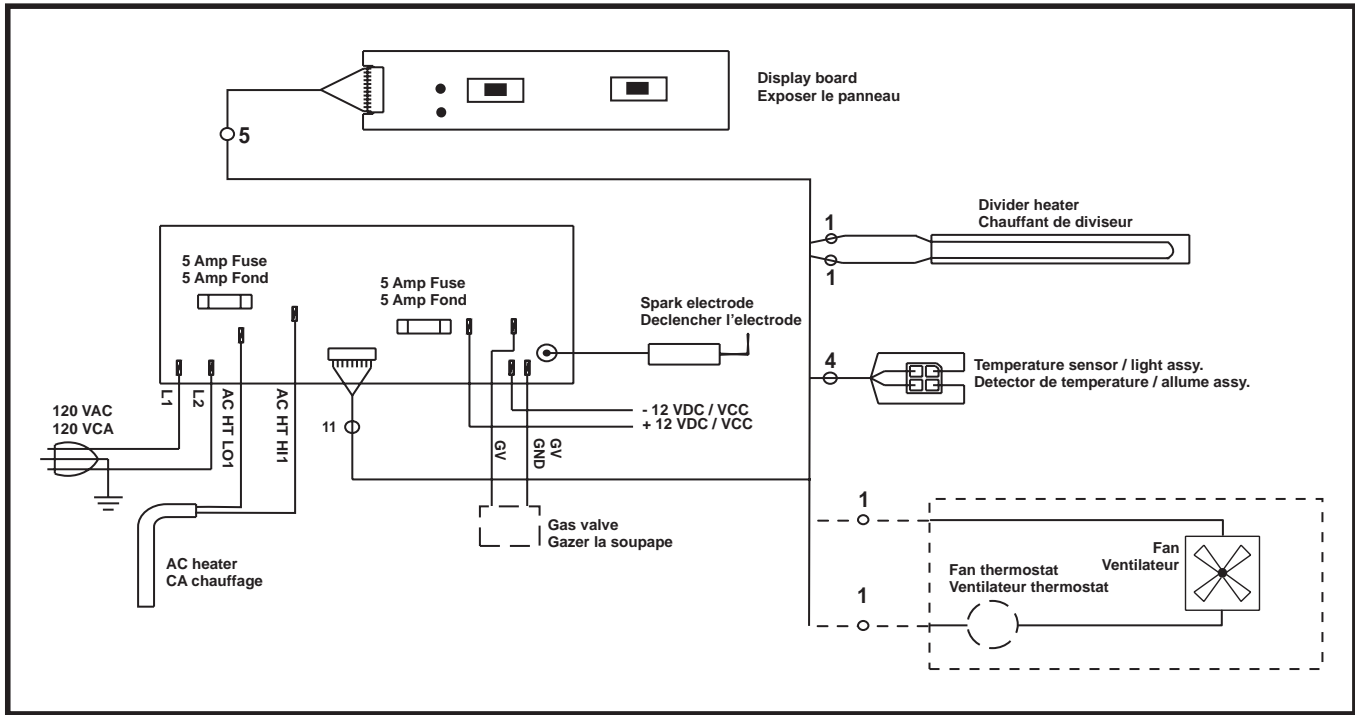

N61X/N81X Wiring Pictorial – S/N 9056491 and lower

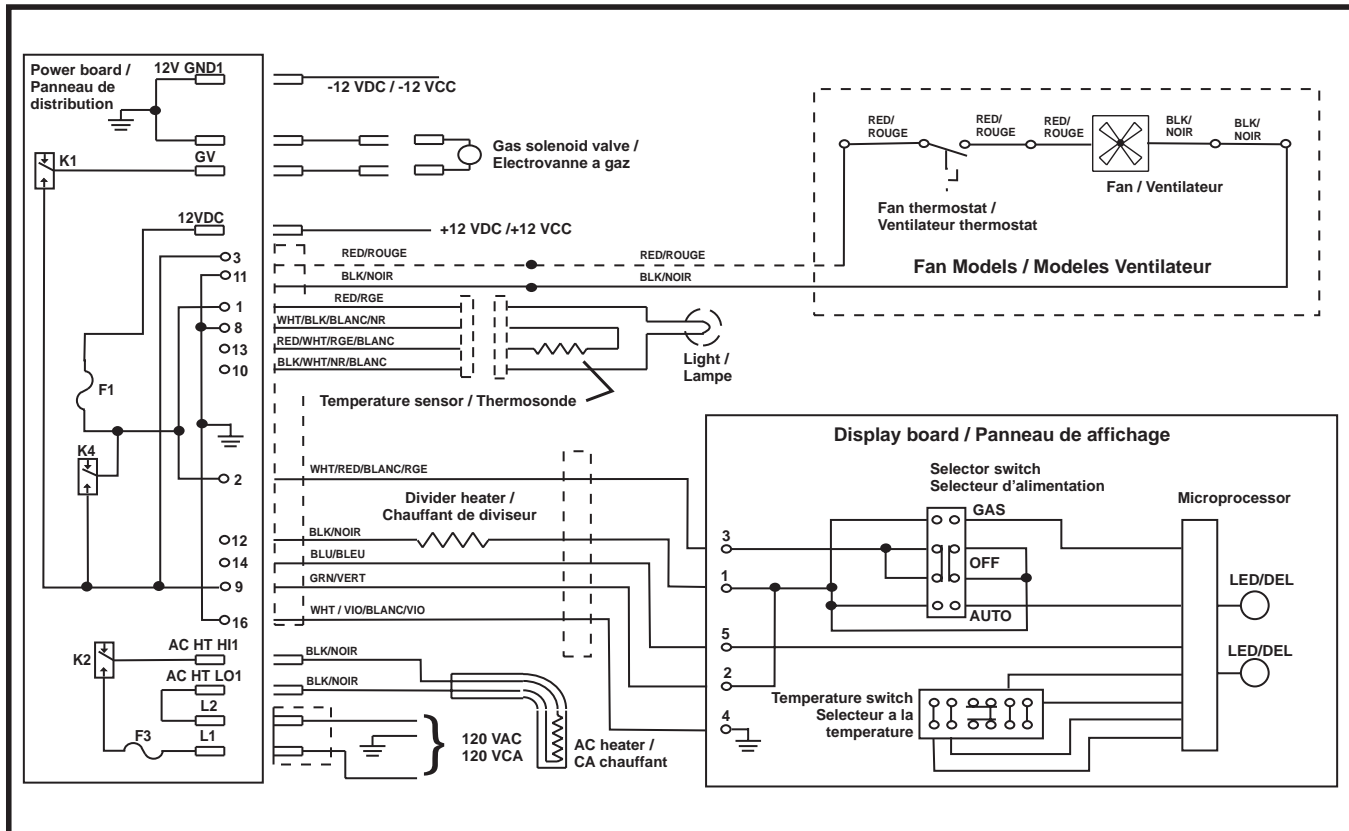

N61X/N81X Wiring Schematic. – S/N 9056491 and lower

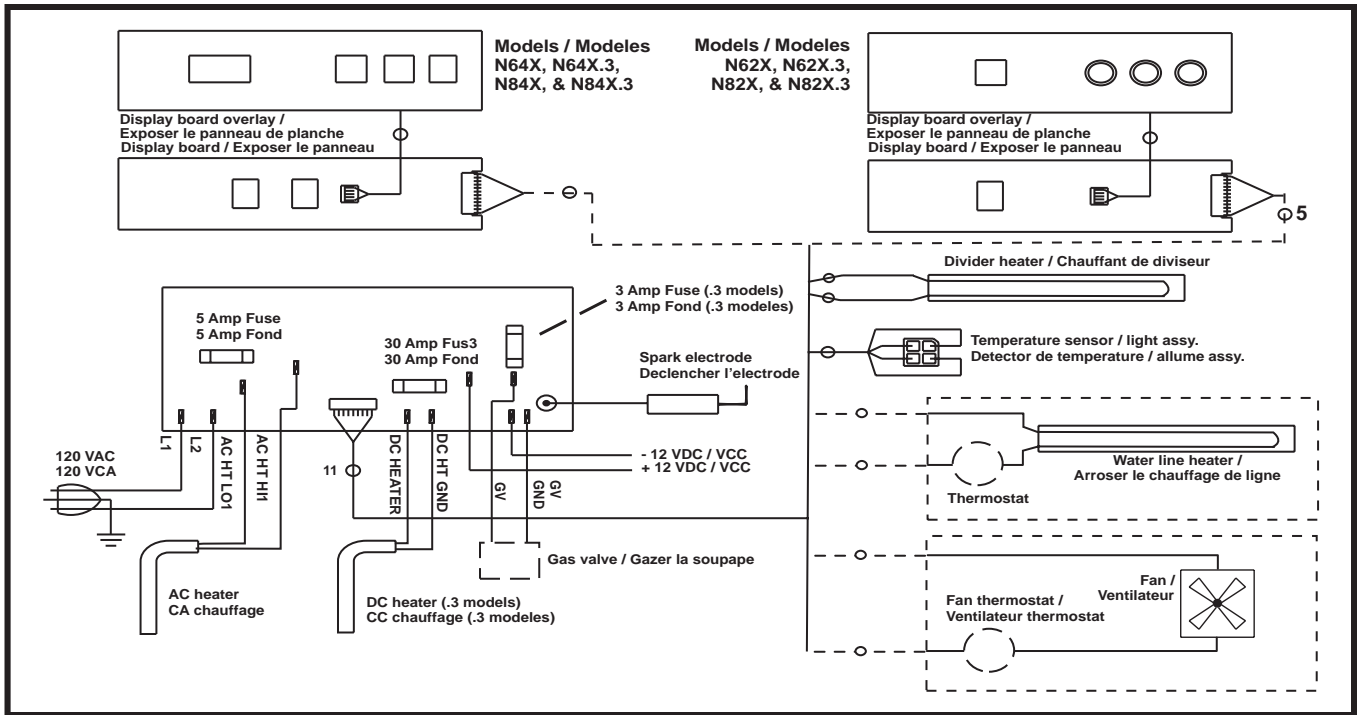

N62X/N82X/N64X/N84X/N64X.3/N84X.3 Wiring Pictorial

N621/N821: Serial numbers between 851759 and 9126825

N623/N823: Serial numbers between 851759 and 8970881

N64/N84: Serial numbers between 851759 and 9044284

N64.3/N84.3: Serial numbers between 851759 and 8938728

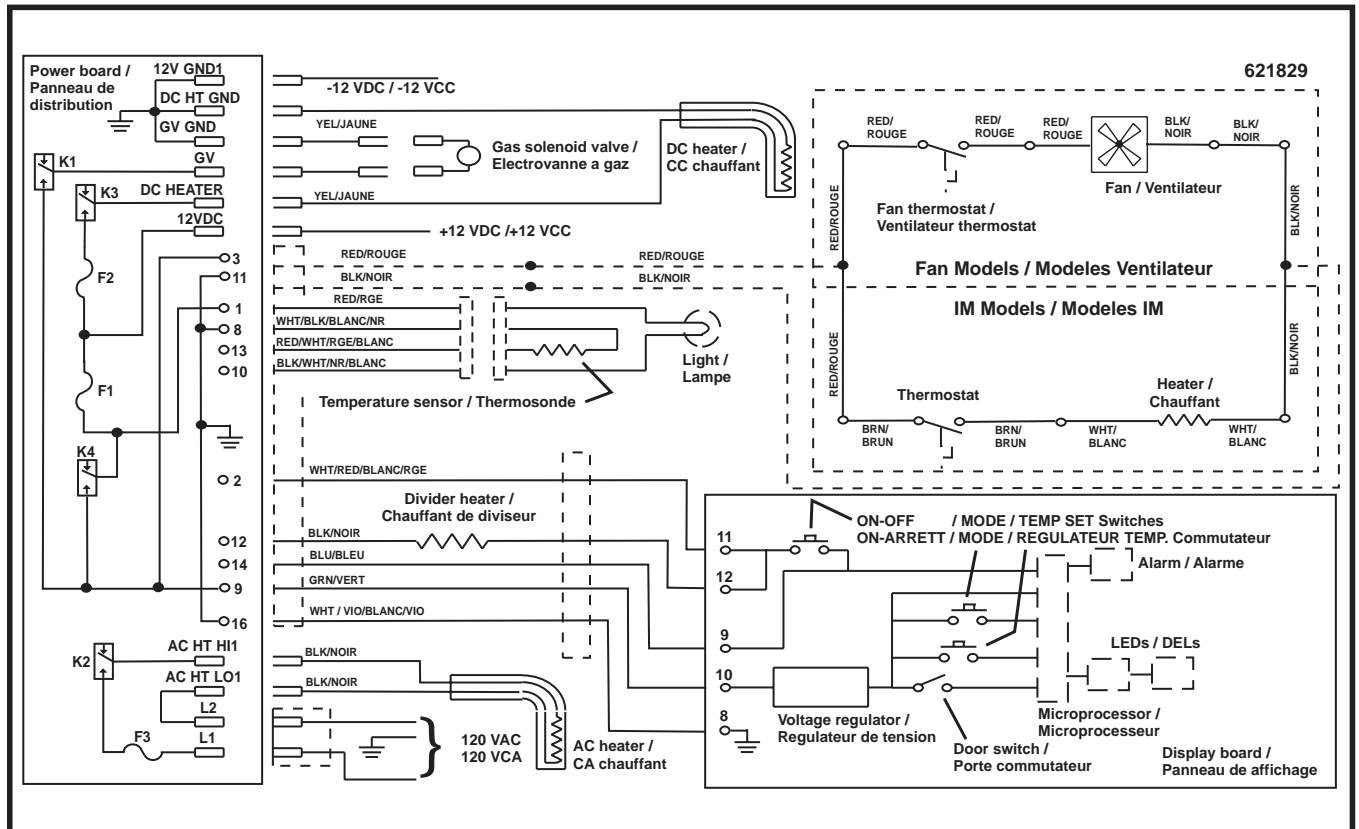

N62X/N82X/N64X/N84X/N64X.3/N84X.3 Wiring Schematic

N621/N821: Serial numbers between 851759 and 9126825

N623/N823: Serial numbers between 851759 and 8970881

N64/N84: Serial numbers between 851759 and 9044284

N64.3/N84.3: Serial numbers between 851759 and 8938728

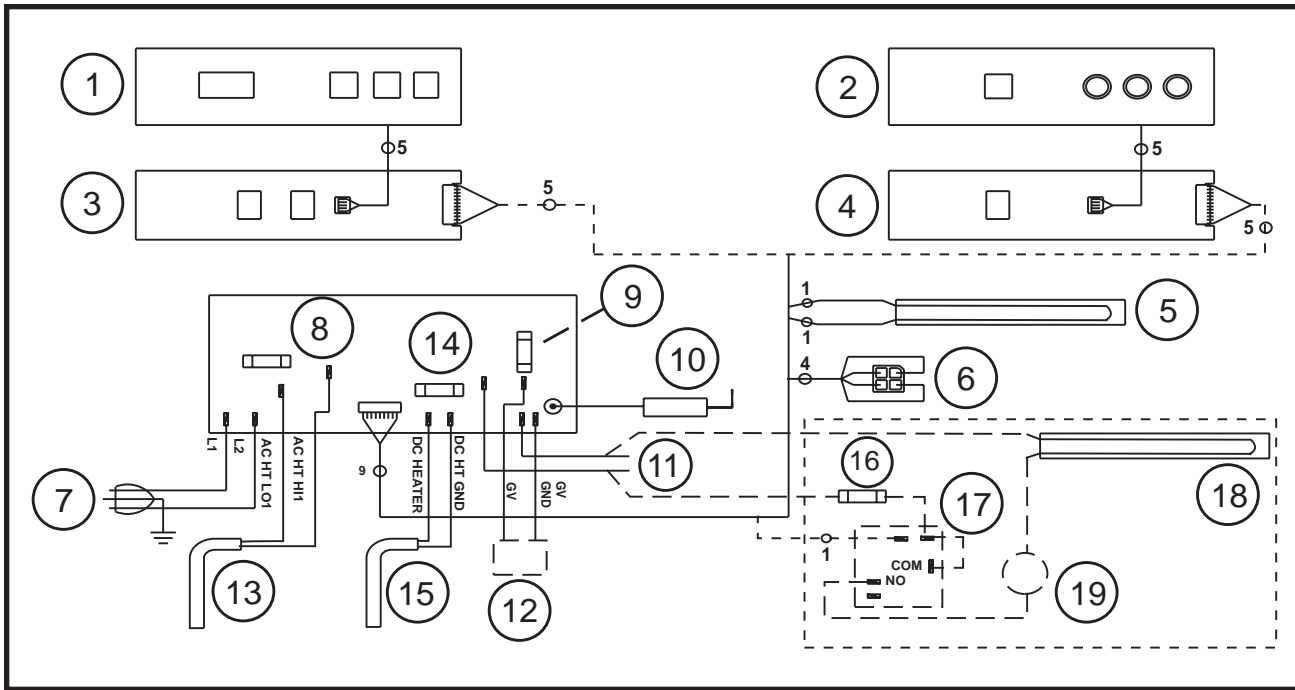

N62X/N82X/N64X/N84X/N64X.3/N84X.3 Wiring Pictorial

N621/N821: Serial numbers between 851759 and 9126825

N623/N823: Serial numbers between 851759 and 8970881

N64/N84: Serial numbers between 851759 and 9044284

N64.3/N84.3: Serial numbers between 851759 and 8938728

- | | |
|---------------------------------------|--|
| ① N62X/N82X Display overlay | ⑪ 12 Vdc connections |
| ② N64X/N84X Display overlay | ⑫ Gas valve |
| ③ N62X/N82X Display circuit board | ⑬ AC heater |
| ④ N64X/N84X Display circuit board | ⑭ Fuse, 30 amp/auto blade type, 3-way models |
| ⑤ Divider heater | ⑮ DC heater, 3 way models only |
| ⑥ Lamp/Thermistor | ⑯ Fuse, 3 amp for water line heater |
| ⑦ AC power cord | ⑰ Relay, water line heater |
| ⑧ Fuse, 5 amp/AGC type | ⑱ Water line heater |
| ⑨ Fuse, 5 amp/standard auto type | ⑲ Thermostat, water line heater |
| ⑩ Spark/sense electrode wire assembly | |

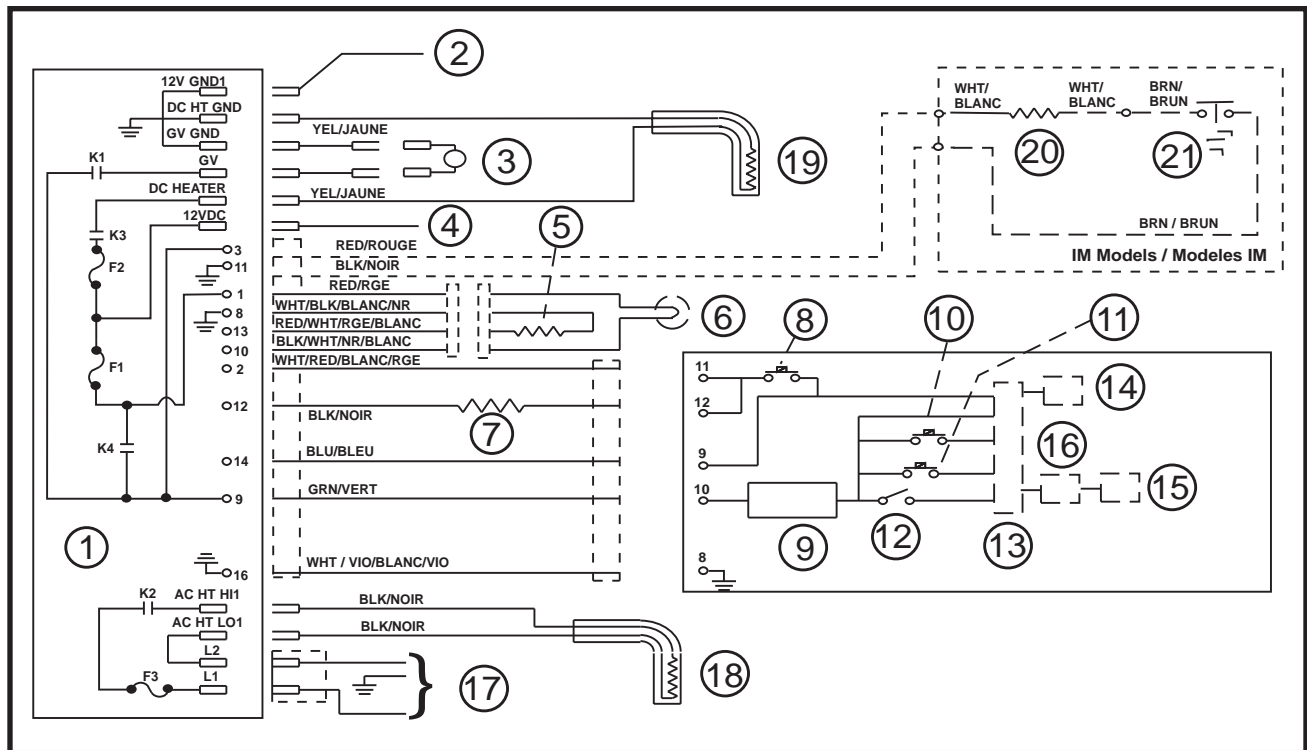

N62X/N82X/N64X/N84X/N64X.3/N84X.3 Wiring Schematic

N621/N821: Serial numbers between 851759 and 9126825

N623/N823: Serial numbers between 851759 and 8970881

N64/N84: Serial numbers between 851759 and 9044284

N64.3/N84.3: Serial numbers between 851759 and 8938728

- | | |
|---------------------------------|------------------------------------|
| ① Power board | ⑪ TEMP SET switch |
| ② -12 Vdc connection | ⑫ Door switch |
| ③ Gas valve | ⑬ Microprocessor |
| ④ +12 Vdc connection | ⑭ Alarm, N64X/N84X units only |
| ⑤ Thermistor | ⑮ 7-segment LED N64X/N84X units |
| ⑥ Light, fresh food compartment | ⑯ LED |
| ⑦ Divider heater | ⑰ 120 Vac connection |
| ⑧ On/OFF switch | ⑱ AC heater |
| ⑨ Voltage regulator | ⑲ DC heater, 3 way units only |
| ⑩ Mode switch | ⑳ Heater, ice maker water line |
| | ㉑ Thermostat, ice maker water line |

Later Versions of Power Boards

Later control versions (shown below) were used in the manufacture models with these serial numbers:

N623/N823 Models: S/N 8970881 or higher

N64x/N84x Models: S/N 9044284 or higher

N61x/N81x Models: S/N 9056492 or higher

N621/N821 Models: S/N 9126825 or higher

N64.3/N84.3 Models: S/N 8938728 or higher

Removal—Power Board

1. Turn OFF refrigerator.
2. Turn OFF RV DC power to the refrigerator.
3. Disconnect DC power supply wires from power board terminals 12 VDC and GND.



2-Way Power Board

N623/N823 Models: S/N 8970881 or higher
N64x/N84x Models: S/N 9044284 or higher
N61x/N81x Models: S/N 9056492 or higher
N621/N821 Models: S/N 9126825 or higher



2-Way Power Board with Cover

N623/N823 Models: S/N 8970881 or higher
N64x/N84x Models: S/N 9044284 or higher
N61x/N81x Models: S/N 9056492 or higher
N621/N821 Models: S/N 9126825 or higher

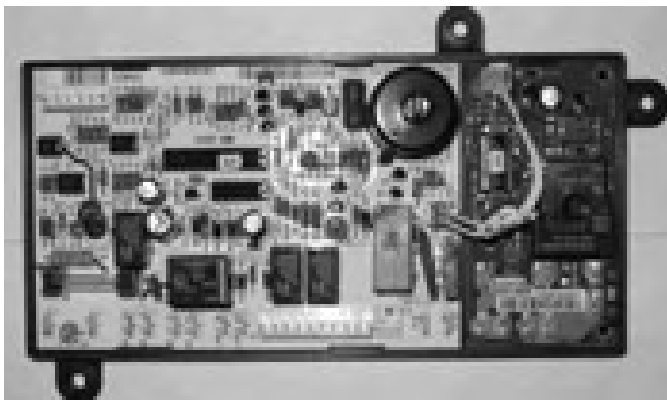

3-Way Power Board

N64.3/N84.3 Models: S/N 8938728 or higher



3-Way Power Board with Cover

N64.3/N84.3 Models: S/N 8938728 or higher

MODELS / MODELES - N61X & N81X

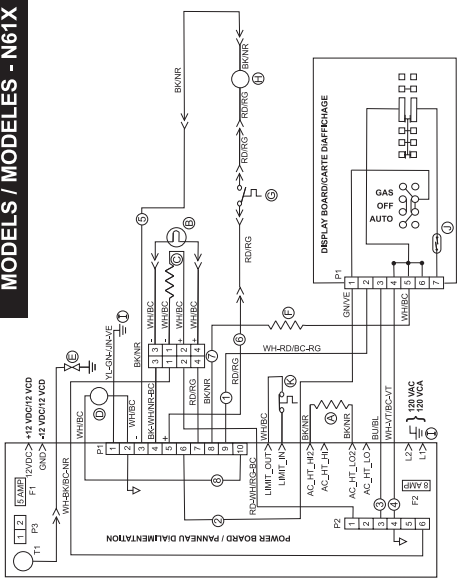

- (A) AC HEATER / ...L...MENT CHAUFFANT CA
- (B) LIGHT / LAMPE
- (C) THERMISTOR / THERMISTANCE
- (D) GAS VALVE / ROBINET DE GAZ
- (E) IGNITER / ALLUMEUR
- (F) DIVIDER HEATER / ELEMENT DE CLOISON
- (G) TEMPERATURE SWITCH / INTERRUPTEUR DE TEMP...RATURE
- (H) FAN / VENTILATEUR
- (I) CHASSIS GROUND / MASSE DU CHASSIS
- (J) DOOR SWITCH / CONTACTEUR DE PORTE
- (K) TEMPERATURE SWITCH / INTERRUPTEUR DE TEMP...RATURE
- * - OPTIONAL / FACULTATIF
- (1) SWITCHED 12VDC / COMMUT... 12VDC
- (2) FUSED CONTINUOUS 12VDC / CONTINU FONDUI 12VDC
- (3) COMMUNICATIONS / COMMUNICATIONS
- (4) DISPLAY GROUND / AFFICHAGE LA TERRE
- (5) AUXILIARY GROUND / MASSE AUXILIAIRE
- (6) AUXILIARY +12VDC / AUXILIAIRE +12VDC
- (7) DIVIDER +12VDC / DE CLOISON +12VDC
- (8) GAS VALVE +12VDC / ROBINET DE GAZ +12VDC
- (9) 5 AMP DC FUSE / FUSIBLE DE 5 AMPERES CD
- (10) 8 AMP AC FUSE / FUSIBLE DE 8 AMPERES CA

N61X/N81X Wiring Schematic

Model	Serial No.	Manufacture Date
N61/N81	9056492 and higher	After 3/23/2006
N621/N821	9126825 and higher	After 4/11/2006
N623/N823	8970881 and higher	After 3/1/2006
N64/N84	9044284 and higher	After 3/22/2006
N64.3/N84.3	8938728 and higher	After 2/21/2006

CU 630071

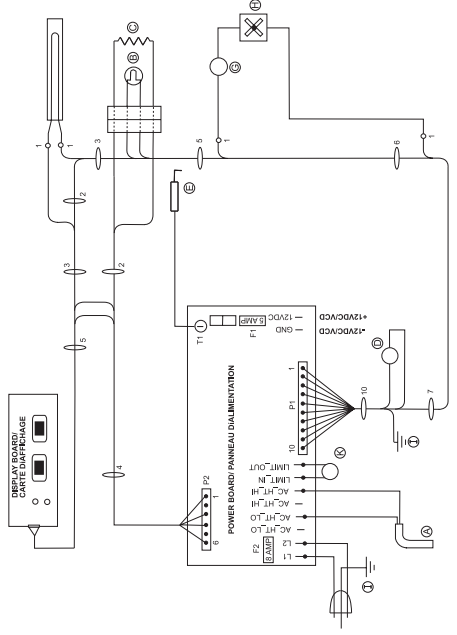

MODELS / MODELES - N62X, N64X, N82X, N84X, N84X, & N109X

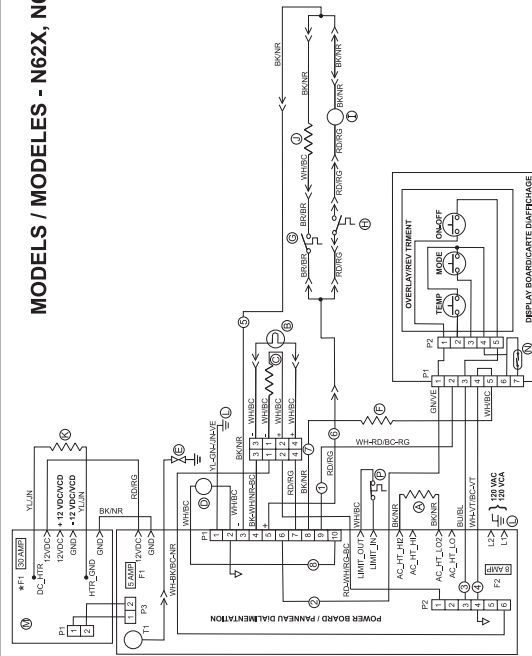

- (A) AC HEATER / ...L...MENT CHAUFFANT CA
- (B) LIGHT / LAMPE
- (C) THERMISTOR / THERMISTANCE
- (D) GAS VALVE / ROBINET DE GAZ
- (E) IGNITER / ALLUMEUR
- (F) DIVIDER HEATER / ELEMENT DE CLOISON
- (G) TEMPERATURE SWITCH / INTERRUPTEUR DE TEMP...RATURE
- (H) FAN / VENTILATEUR
- (I) CHASSIS GROUND / MASSE DU CHASSIS
- (J) DOOR SWITCH / CONTACTEUR DE PORTE
- (K) TEMPERATURE SWITCH / INTERRUPTEUR DE TEMP...RATURE
- * - OPTIONAL / FACULTATIF
- (1) SWITCHED 12VDC / COMMUT... 12VDC
- (2) FUSED CONTINUOUS 12VDC / CONTINU FONDUI 12VDC
- (3) COMMUNICATIONS / COMMUNICATIONS
- (4) DISPLAY GROUND / AFFICHAGE LA TERRE
- (5) AUXILIARY GROUND / MASSE AUXILIAIRE
- (6) AUXILIARY +12VDC / AUXILIAIRE +12VDC
- (7) DIVIDER +12VDC / DE CLOISON +12VDC
- (8) GAS VALVE +12VDC / ROBINET DE GAZ +12VDC
- (9) 5 AMP DC FUSE / FUSIBLE DE 5 AMPERES CD
- (10) 8 AMP AC FUSE / FUSIBLE DE 8 AMPERES CA
- (11) 30 AMP AC FUSE / FUSIBLE DE 30 AMPERES CD

CU 630772



Optical Control Assembly

The optical control assembly is attached to the cabinet divider with two pan head Phillips screws. Optical control assembly removal and installation instructions, according to models, can be found in the following pages:

- Page 55, N61X/N81X models.
- Page 57, N62X/N82X models.
- Page 60, N64X/N84X models.



N61X/N81X Optical Control Assembly



N62X/N82X Optical Control Assembly

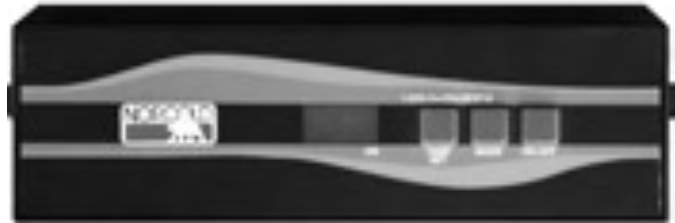

N64X/N84X Optical Control Assembly

Figure 35. N6XX/N8XX Optical Control Assemblies

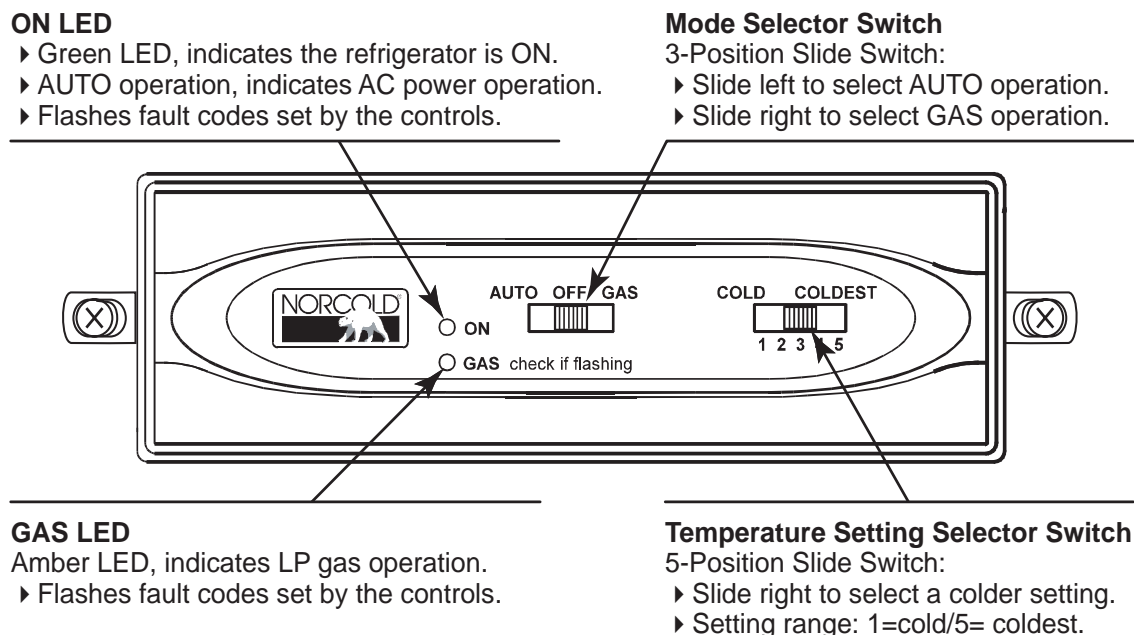

Figure 36. N61X/N81X Optical Control Assembly.

N61X/N81X Optical Control Assembly

The optical control assembly communicates with the power board through a "foamed in" wire harness. Drilling or puncturing the refrigerator rear panels may cause damage to the wire harness. Controls and related features are shown in Figure 36. The optical control assembly with front box attached is shown in Figure 37. The optical control assembly connected to the wire harness is shown in Figure 38.

Front Box

Two tabs lock the front box to the optical control assembly. A retaining screw on the hinge side retains the front box to the divider. Shifting the refrigerator door swing requires shifting the front box to the selected hinge side.

Removal and Installation of Optical Control Assembly.

To remove the optical control assembly:

1. Turn off the refrigerator.
2. Remove the front box retaining screw, then remove the front box.
3. Remove the optical control assembly retaining screws.
4. Disconnect the optical control assembly from the wire harness.

To install the optical control assembly:

1. Connect the optical control assembly to the wire harness.

3. Reinstall the front box. Do not overtighten the retaining screw.
4. Turn on the refrigerator, then check all of the optical control assembly functions.



Figure 37. N61X/81X Optical Control Assembly With Front Box.



Figure 38. Wire Harness Connection.

Modes of Operation

AUTO Mode

In AUTO mode, the controls automatically search for AC power first. If AC power is present, the controls automatically select AC operation. The selection of AC power is indicated by the ON LED.

No AC Power

If AC power is not present or is interrupted, the controls automatically switch to LP gas operation. When the controls switch to LP gas operation, the GAS LED illuminates and a 30 second trial for ignition period starts. Both ON LED and GAS LED will remain illuminated. The ON LED indicates the refrigerator is turned ON. The GAS LED indicates the controls selected LP gas because AC power is not available.

AC Power Restored

If AC power is restored the controls automatically revert operation to AUTO AC and the GAS LED turns off. The ON LED will remain illuminated to indicate AUTO AC operation.

No AC and No Flame

If AC power is not present and a flame is not sensed after the controls switch to LP gas, the flame sensing circuit places the controls in "gas lock-out." In turn, the controls command the ON LED and GAS LED to flash at one second intervals.

The "A"/"no AC" flowchart on page 16 provides information to troubleshoot no AC power faults.

The "F"/"no FL" flowchart on page 12 provides information to troubleshoot no flame faults.

GAS Mode

In GAS mode, the controls will only select LP gas for operation. GAS mode operation is monitored by the flame sensing circuit. Normal GAS mode operation is indicated by the GAS LED.

No Flame

In GAS mode, if a flame does not ignite during the 30 second trial for ignition, or the flame goes out, the flame sensing circuit shuts off power to the gas valve and places the controls in "gas lock-out." In turn, the controls command the GAS LED to flash off at one second intervals.

The "F"/"no FL" flowchart on page 12 provides information to troubleshoot no flame faults.

Backup Operating System

The Backup Operating System (BOS) allows cooling to continue if the thermistor should fail. BOS is a duty cycle operation. The duration of the cooling cycle can be regulated by adjusting the temperature setting. The higher the temperature setting number, the longer the cooling cycle operates.

When the controls switch operation to BOS, the ON LED flashes once every three seconds. The flowchart on page 20 provides thermistor troubleshooting information.

"Gas Lock-Out"

"Gas lock-out" prevents the controls from automatically attempting to reignite the burner after the controls have detected an ignition failure. "Gas lock-out" may be caused by any or a combination of the following:

- No LP gas available (empty LP gas tank).
- Incorrect LP gas pressure (LP gas pressure must be 10.5 to 11.5 inches water column).
- Dirty burner.
- Clogged, damaged, or the wrong orifice.
- Incorrect electrode-to-burner air gap.
- A damaged or grounded spark/sense electrode assembly.
- Damaged or inoperable gas valve.

To manually clear "Gas Lock-Out":

- Turn OFF the refrigerator.
- Correct the no flame fault.
- Select AUTO or GAS operation.

TEMP SET Switch

- ▶ Press momentarily to view temperature setting.
- ▶ Press and hold to select desired temperature setting.
- ▶ Settings: 1= cold/9= coldest.

Power Switch

- ▶ Press momentarily to turn ON refrigerator.
- ▶ Press and release after three seconds to turn OFF refrigerator.

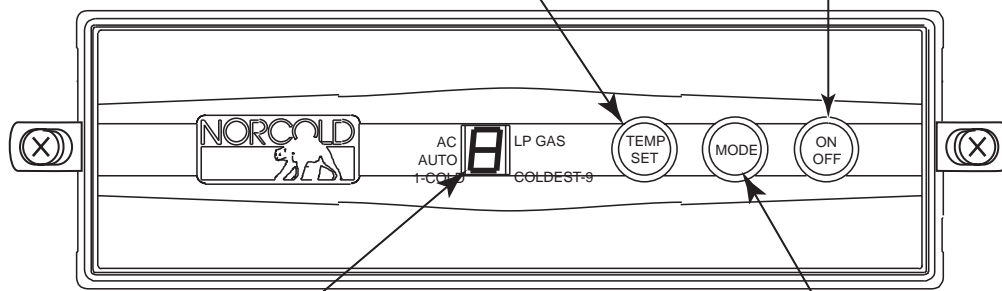

7-Segment LED Display Shows:

- ▶ Normal operation on AUTO and LP GAS.
- ▶ Fault codes set by the control system.
- ▶ Temperature setting.
- ▶ Diagnostic information.

MODE Switch

- ▶ Press momentarily to display operating mode.
- ▶ Press and hold to select AUTO, AC-Manual, or LP Manual mode. Release when desired mode displays.

Figure 39. N62X/N82X Optical Control Assembly.

N62X/N82X Optical Control Assembly

The optical control assembly communicates with the power board through a "foamed in" wire harness. Drilling or puncturing the refrigerator rear panels may cause damage to the wire harness. Controls and related features are shown in Figure 39. The optical control assembly with front box attached is shown in Figure 40. The optical control assembly connected to the wire harness is shown in Figure 41.

Front Box

Two tabs lock the front box to the optical control assembly. A retaining screw on the hinge side retains the front box to the divider. Shifting the refrigerator door swing requires shifting the front box to the selected hinge side.

Removal and Installation of Optical Control Assembly

To remove the optical control assembly:

1. Turn OFF the refrigerator.
2. Remove the front box retaining screw, then remove the front box.
3. Remove the optical control assembly retaining screws.
4. Disconnect the optical control assembly from the wire harness.

To install the optical control assembly:

1. Connect the optical control assembly to the wire harness.

3. Reinstall the front box. Do not overtighten the retaining screw.
4. Turn on the refrigerator, then check all of the optical control assembly functions.



Figure 40. N62x/82x Optical Control Assembly With Front Box.



Figure 41. Wire Harness Connection.

Modes of Operation

All N62X and N82X are designed for 2-way operation.

AUTO Mode

In AUTO mode, AC power is the first heat energy source selected by the controls. If AC power is not present, the controls shift to LP gas (propane), the controls second priority heat energy source.

AUTO AC Operation

1. Mode of operation is indicated by the AUTO LED.

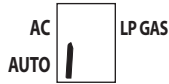

2. The AC LED comes on as the controls search for AC power availability.



3. The AC LED turns off when AC power is selected by the controls. Mode operation is indicated by the AUTO LED. See NOTE 1.

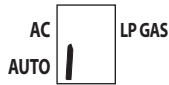

NOTE 1

In AUTO mode, pressing the MODE switchbutton momentarily displays the heat energy source in use. For example, in AUTO AC, the AC LED will come on and stay on for approximately 10 seconds.

AUTO LP Gas Operation

In AUTO mode, the controls shift to LP gas when AC power is not available or interrupted. The shift to AUTO LP is as follows:

1. The AUTO LED indicates the unit is on and operating in AUTO mode.



2. The AC LED comes on as the controls verify AC power availability.

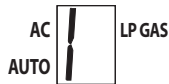

3. Since AC power is not present, the controls shift to LP gas. The LP LED comes on to signal the start of a 30 seconds trial-for ignition.

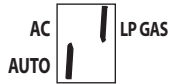

4. The controls sense the flame, turn off the LP GAS LED leave the AUTO LED on to indicate AUTO mode operation.



Shift from AUTO LP GAS to AUTO AC

In AUTO mode, the controls shift automatically from AUTO LP GAS back to AUTO AC when the controls detect that AC power has become available.

No AC Power and No Flame

When AC power is not present and a flame is not sensed, the controls:

1. Acknowledge both faults after the 30 seconds trial-for ignition is over.
2. Shut power to the solenoid gas valve.
3. Set "gas lock-out". See NOTE 2.
4. Provide a visual warning by flashing alternating **A** (no AC) and **F** (no flame) fault codes, shown below. See NOTE 3.

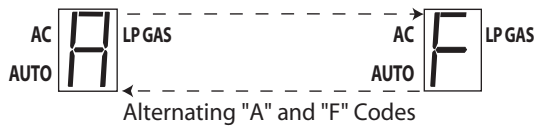

5. Record and store the no AC and no flame faults in diagnostics nonvolatile memory fault history.

NOTE 2

In AUTO mode, the controls maintain "gas lock-out" until a full cooling cycle on AUTO AC is completed. Turning the refrigerator OFF and back ON also clears "gas lock-out".

NOTE 3

N62X/N82X models with serial number 854467 and lower equipped with the original power board (p/n 619353) and optical control assembly (p/n 619350) will only display fault indicator **A**.

Troubleshooting a "F"/"no" "FL" and "A"/"no" "AC" Faults

Use the following references to identify, troubleshoot, and correct an ignition failure and/or no AC faults.

- Page 12, "F"/"no" "FL" fault codes troubleshooting flowchart.
- Page 16, "A"/"no" "AC" fault codes troubleshooting flowchart.
- Page 65, Diagnostic Mode—N62X/N82X Models, Screen 4.

AC-Manual Mode

When the AC-Manual Mode is selected, AC power is the only heat energy source selected by the controls. When the AC-Manual Mode is selected:

1. Mode of operation selected is indicated by the AC LED.

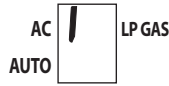

2. The AC LED stays on as long as the AC-Manual Mode is selected.

No AC Power or Loss of AC Power

When no AC power or AC power is lost, the controls:

1. Provide a visual warning by flashing the **A** (no AC) fault code.



2. Record and store the no AC fault in diagnostics nonvolatile memory fault history.

Troubleshooting a "A"/"no" "AC" Fault

Use the following references to identify, troubleshoot, and correct a no AC fault.

- Page 16, "A"/"no" "AC" fault codes troubleshooting flowchart.
- Page 65, Diagnostic Mode–N62X/N82X Model, Screen 4.

AC Power Restored

When AC power is restored to the power board, the controls:

1. Automatically restore AC-Manual Mode operation.
2. Clear the "A" fault code from the screen. However, the recorded fault history will not be erased from memory.
3. Display the AC LED.

LP Gas–Manual Mode

When LP GAS-Manual Mode is selected, LP gas (propane) is the only heat energy source selected by the controls. When the LP GAS-Manual Mode is selected:

1. Mode of operation is indicated by the LP LED.



2. The LP GAS LED stays on as the LP GAS-Manual Mode is selected.

Flame Fails to Ignite or Flame Goes Out

If a flame does not ignite or the flame goes out, the controls:

1. Set "gas lock-out" and shut off power to the solenoid gas valve.

2. Provide a visual warning by flashing the **F** (no flame) fault code.



3. Record and store the no flame fault in diagnostics nonvolatile memory fault history.

Clearing "Gas Lock-Out"

"Gas lock-out" can be cleared by turning the refrigerator OFF and back ON.

Troubleshooting a "F"/"no" "FL" Fault

Use the following references to identify, troubleshoot, and correct an ignition failure fault.

- Page 16, "F"/"no" "FL" fault codes troubleshooting flowchart.
- Page 65, Diagnostic Mode–N62X/N82X Model, Screen 4.

TEMP SET Switch

- ▶ Press momentarily to view temperature setting.
- ▶ Press and hold to select a temperature setting.
- ▶ Settings: 1= cold/9= coldest.

Power Switch

- ▶ Press momentarily to turn ON refrigerator.
- ▶ Press and release after three seconds to turn OFF refrigerator.

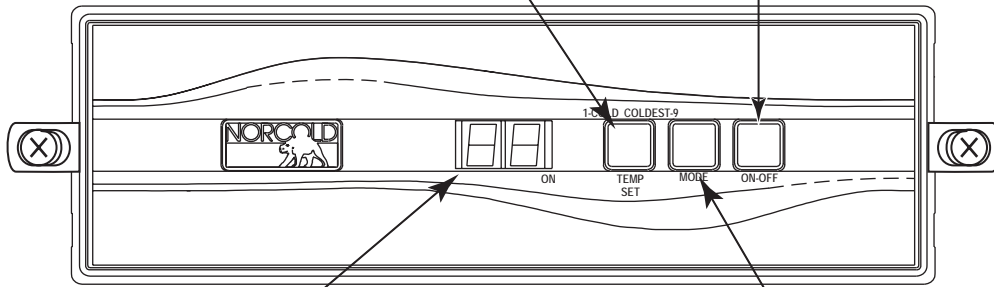

Two, 7-Segment LED Display

Show:

- ▶ Operation mode AUTO, AC, LP and DC (3-way models only).
- ▶ Fault codes and diagnostic information.
- ▶ Temperature setting.

MODE Switch

- ▶ Press momentarily to display operating mode.
- ▶ Press and hold to select AUTO, AC or LP Manual Mode, or DC Manual Mode (3-way models only). Release when desired mode displays.

Figure 42. N64X/N84X Optical Control Assembly.

N64X/N84X Optical Control Assembly

The optical control assembly communicates with the power board through a "foamed in" wire harness. Drilling or puncturing the refrigerator rear panels may cause damage to the wire harness. Controls and related features are shown in Figure 42. The optical control assembly with front box attached is shown in Figure 43. The optical control assembly connected to the wire harness is shown in Figure 44.

Front Box

Two tabs lock the front box to the optical control assembly. A retaining screw on the hinge side retains the front box to the divider. Shifting the refrigerator door swing requires shifting the front box to the selected hinge side.

Removal and Installation of Optical Control Assembly

To remove the optical control assembly:

1. Turn off the refrigerator.
2. Remove the front box retaining screw, then remove the front box.
3. Remove the optical control assembly retaining screws.
4. Disconnect the optical control assembly from the wire harness.

To install the optical control assembly.

1. Connect the optical control assembly to the wire harness.

3. Reinstall the front box. Do not overtighten the retaining screw.
4. Turn on the refrigerator, then check all of the optical control assembly functions.



Figure 43. N64X/N84X Optical Control Assembly With Front Box.

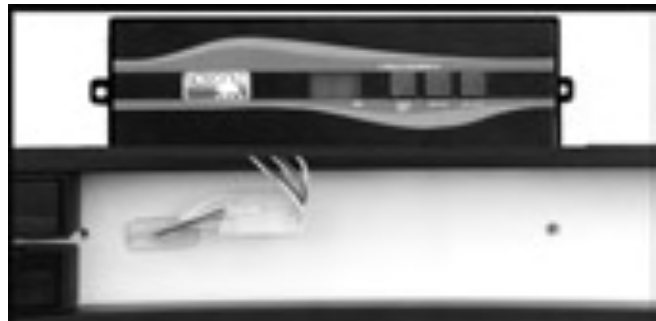

Figure 44. Wire Harness Connection.

Modes of Operation

AUTO

In AUTO mode, AC power is the first heat energy source selected by the controls. If AC power is not present, the controls shift to LP gas (propane), the second priority heat energy source.

AUTO – N64X.3/N84X.3 (3-way units)

In 3-way units, if LP gas if a flame is not sensed, then flame goes out, or an ignition failure occurs, the controls shift to DC power, the third priority heat energy source. For additional information on 3-way units AUTO mode, see page 58.

AUTO AC Operation

When the AUTO mode is selected, the controls:

1. Display AUTO ("AU") mode operation indicator.
2. Flashes "AU" and "AC" as the search for AC power begins.
3. Turn off "AU" and "AC" when AC power is selected and displays the ON LED. See NOTE 1.

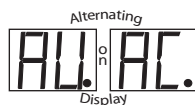

NOTE 1

In AUTO mode, pressing the MODE switchbutton momentarily displays the heat energy source in use. For example, in AUTO AC, the display alternate flashing **AU** and **AC** for approximately 10 seconds.

AUTO LP Operation

The controls shift to AUTO LP mode any time AC power is not available. The controls shift to AUTO LP as follows:

1. The AUTO mode operation indicator ("AU") displays.
2. "AU" and "AC" indicator alternate flashing on the display while the controls search for AC power.
3. When AC power is not present, the controls shift to AUTO LP mode. "AU" and "LP" alternate flashing on the display as the controls start a 30 seconds trial-for ignition.
4. The controls sense the flame, turn off the "AU" and "LP", and display the ON LED. See NOTE 1.

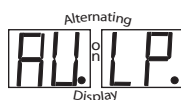
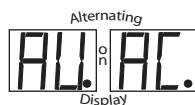

Shift from AUTO LP GAS to AUTO AC

In AUTO mode, the controls shift automatically from AUTO LP GAS to AUTO AC any time the controls sense that AC power is available.

No AC Power and No Flame

When AC power is not present and a flame is not sensed, at the end of the 30 seconds trial-for ignition, the controls:

1. Shut off power to the solenoid gas valve.
2. Set "gas lock-out". See NOTE 2.
3. Sound the alarm (an intermittent beeping tone).
4. Provide a visual warning by flashing alternating "no" "AC" and "no" "FL" (no flame) fault codes shown below).
5. Record and store the "no" "AC" and "no" "FL" faults in diagnostics nonvolatile memory fault history.



NOTE 2

AUTO LP mode remains in "gas lock-out" until a full cooling cycle on AUTO AC is completed. "Gas lock-out" can also be cleared by turning the refrigerator OFF then back ON.

Shift from AUTO LP GAS to AUTO AC

In AUTO mode, the controls shift automatically from AUTO LP GAS back to AUTO AC when the controls detect that AC power has become available.

Troubleshooting No Flame and No AC Faults

Use the following references to identify, troubleshoot, and correct an ignition failure and/or no AC faults.

- Page 12, "F"/"no" "FL" fault codes troubleshooting flowchart.
- Page 16, "A"/"no" "AC" fault codes troubleshooting flowchart.
- Page 65, Diagnostic Mode–N62X/N82X Models, Screen 4.

AUTO DC Operation – 3-Way Units Only

In AUTO DC mode, the controls shift to DC power when AC power is not present and flame is not sensed. The shift to AUTO DC operation does not show on the display. The shift is invisibly performed by the controls. When the controls shift to AUTO DC:

1. The AUTO ("AU") mode operation indicator displays.



2. "AU" and "AC" indicators alternate flashing on the display as the controls search for AC power.

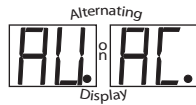

3. When AC power is not present the controls shift to AUTO LP mode. "AU" and "LP" indicators alternate flashing on the display as the controls start a 30 seconds trial-for ignition.

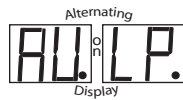

4. Not sensing a flame causes the controls to shift to Auto DC power. The shift to DC power is not displayed. See NOTE 1.

5. The ON LED displays. See NOTE 2.



NOTE 1

Pressing the MODE switchbutton will displays the "AU" and "dc" indicators.

NOTE 2

The auto sequence described in steps 1 through 5 is repeated after the completion of each cooling cycle to enable the controls to select a higher priority heat energy source if available.

The control's priorities for selecting a heat energy source are:

- First priority: AC power.
- Second priority: LP gas.
- Third priority: DC power – 3-way units only.

AC-Manual Mode

In the AC-Manual Mode, AC power is the only heat energy source selected by the controls. When the controls shift to AC-Manual Mode:

1. The AC mode indicator ("AC") displays as the controls start the search for AC power.



2. When AC power is selected, the AC indicator turns off. The ON LED displays. See NOTE 3.



NOTE 3

Pressing the MODE switchbutton displays the "AC" mode indicator.

No AC Power or Loss of AC Power

If the controls do not sense the presence of AC power or when AC power is lost or when the AC input is below 85 VAC, the controls:

1. Display the "no" "AC" fault code.

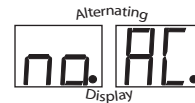

2. Sound the audible alarm. The alarm is an intermittent beeping tone. Pressing the mode switchbutton silences the alarm.
3. Record and store the "no" "AC" fault in diagnostics nonvolatile memory fault history.

AC Power Restored

When AC power is restored, the controls:

1. Automatically restore AC-Manual Mode operation; however, the recorded fault history will not be erased from memory.
2. Silence the alarm and clear then "no" "AC" fault code from the display.

Troubleshooting "no" "AC" Fault

Use the following references to identify, troubleshoot, and correct a no AC fault.

- Page 16, "A"/"no" "AC" fault codes troubleshooting flowchart.
- Page 65, Diagnostic Mode – N62X/N82X Model, Screen 4.

LP-Manual Mode

In the LP-Manual Mode, LP gas is the only heat energy source selected by the controls. When the controls shift to LP-Manual mode:

1. The LP mode indicator ("LP") displays and the controls start a 30 seconds trial-for-ignition.
2. The LP mode indicator turns off when the controls sense a flame. The ON LED displays. See NOTE below.



DC-Manual Mode

The DC-Manual Mode is the only heat energy source acknowledged and selected by the controls. When the controls shift to DC-Manual mode:

1. DC mode indicator ("dc") displays as the controls start the search for DC power.
2. The dc mode indicator turns off when the controls shift to DC power. The ON LED displays. See NOTE below.



NOTE 4

Pressing the MODE switchbutton displays the "LP" mode indicator.

NOTE 6

Pressing the MODE switchbutton displays the "dc" mode indicator.

Flame Fails to Ignite or Flame Goes Out

If the controls do not sense a flame within the 30 seconds trial-for-ignition, the controls:

1. Shut-off power to the solenoid gas valve.
2. Set "gas lock-out." See NOTE 5 below.
3. Display a flashing visual warning, "no" "FL" (shown below).
4. Sound an audible alarm. The alarm is an intermittent beeping tone. Pressing the mode switchbutton silences the alarm.

NOTE 5

AUTO LP mode remains in "gas lock-out" until a full cooling cycle on AUTO AC is completed. "Gas lock-out" can also be cleared by turning the refrigerator OFF then back ON.

No DC Power to DC Heater Circuit

If the controls do not sense that DC power is available to the DC heater circuit, the controls:

1. Display the "dc" "HE" fault code.

2. Sound the audible alarm. The alarm is an intermittent beeping tone. Pressing the mode switchbutton silences the alarm.

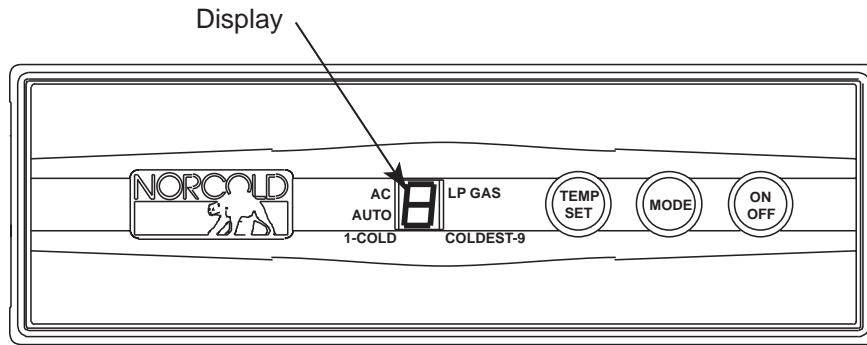

Figure 45. N62X0/N82X Optical Control Assembly.

Diagnostic Mode

The Diagnostic Mode uses nine diagnostic channels, commonly known as "screens", to display "live" inputs, outputs, and fault history. Each screen is identified by a number, which shows in the optical control assembly display. See Figure 45.

The N62X/N82X optical control display uses a single 7-segment LED module to display diagnostic information. Information made up of two letter or numbers display in an alternating sequence. Fault history information, "live" inputs, and outputs, are presented using lighted LED segments. The diagnostic LED segments, if present, displays after the screen number turns off. Diagnostic LED segments identification numbers. See Figure 46.

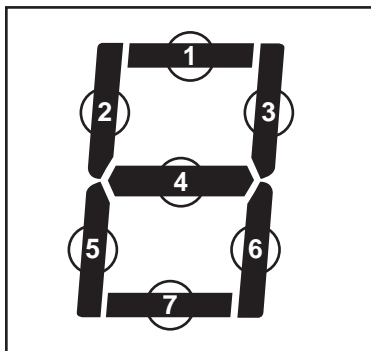







Figure 46. Diagnostic LEDs Segments Identification.

Accessing the Diagnostic Mode

To access the Diagnostic Mode:





1. **Press and hold both** the  and  buttons **at the same time.**
2. **Release** the  and  as soon as screen  displays.
3. A few seconds later,  displays.

Changing Screens

To change screens, **Press**  the button until the next screen displays.

Exiting the Diagnostic Mode

To exit the Diagnostic Mode:

1. **Press and hold** the  and  buttons **at the same time.**
2. **Release** the  and  buttons as soon as the LED segment that represents the selected operation mode appears on the display (AUTO, AC, or LP GAS).

Turning the refrigerator OFF then back ON also exits the Diagnostic Mode

Screens and Diagnostic Segments Information

Screen 1 Diagnostic Mode Active

Screen 1 confirms that the Diagnostic Mode is active. A few seconds after the number displays, all LED segments light. See illustration

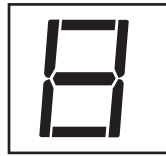

If the LED segments do not match the illustration, the fault is in the optical control display.

Replacing the optical control assembly should resolve this fault.

Press the  button to bring up screen 2.

Screen 2 LED Segments Reliability Check

Screen 2 continues to confirm the reliability of the display. The screen should go completely blank after the screen number is displayed.



If an LED segment displays, the fault is in the optical control assembly.

Replacing the optical control assembly should resolve this fault.

Press the  button to bring up screen 3.

Screen 3 Thermistor Fin Temperature

Screen 3 shows the actual fin temperature being sensed by the thermistor. ***This is not the fresh food cabinet air temperature.*** The illustration shows 30°F fin temperature as displayed in screen 3.

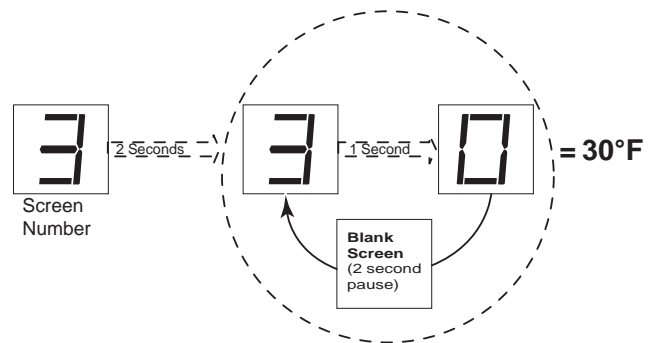

Press the  button to bring up screen 4.

Screen 4 Stored Fault History

Screen 4 displays stored fault history using lighted LED segments. The illustration provides fault information and assigned LED segments. ***If a fault occurred, its assigned LED will light.***

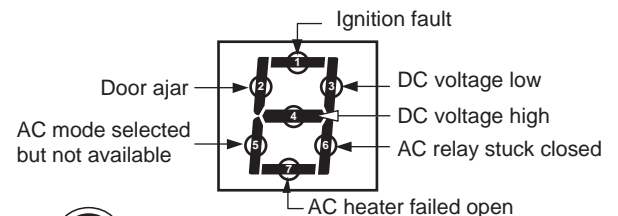

Press the  button to bring up screen 5.

Screen 5 Stored Fault History



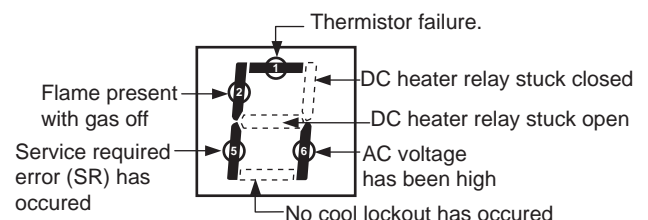





Screen 5 also displays stored fault history using lighted LED segments. The illustration provides fault history information and assigned LED segments. ***If a fault occurred, its assigned LED will light.***



Press the  button to bring up screen 6.

Screen 6 Erase Fault History Data

Screen 6 provides a way to erase stored fault history from memory. To erase stored fault history:

1. Press and hold the  button when  and  display.
2. Release the  button when  and  display.
3. Wait five seconds.
4. Press and hold the  button until  and  display again.

Press the  button to bring up screen 7.

Screen 8 Power Board Outputs

Screen 8 display "live" power board outputs using lighted LED segments. The illustration below provides "live" outputs information and assigned LED segments. **If the power board output is active or "live," the assigned LED will light.**

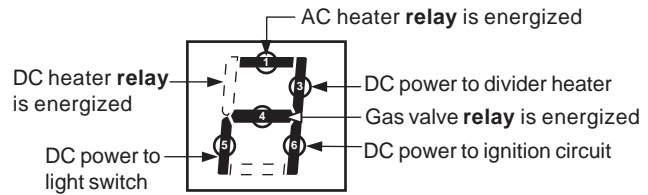

Press the  button to bring up screen 9.

Screen 7 Power Board Inputs

Screen 7 displays "live" power board inputs using lighted LED segments. The illustration below provides "live" inputs information and assigned LED segments. **If a power board input is active or "live", its assigned LED will light.**

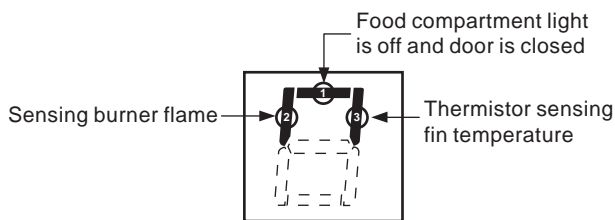

Press the  button to bring up screen 8.

Screen 9 Power Board DC Voltage Status

Screen 9 display power board DC voltage status using lighted LED segments. The illustration below provides DC voltage status and assigned LED segments. **If DC voltage at the power board within normal range (10.5 to 15.4 Vdc), LED segment 4 will be on.**

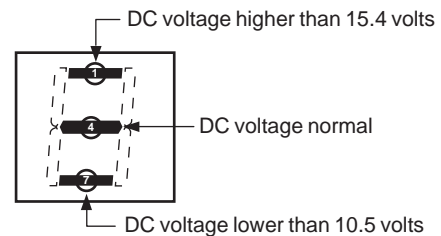

Press the  button to return to screen 1.

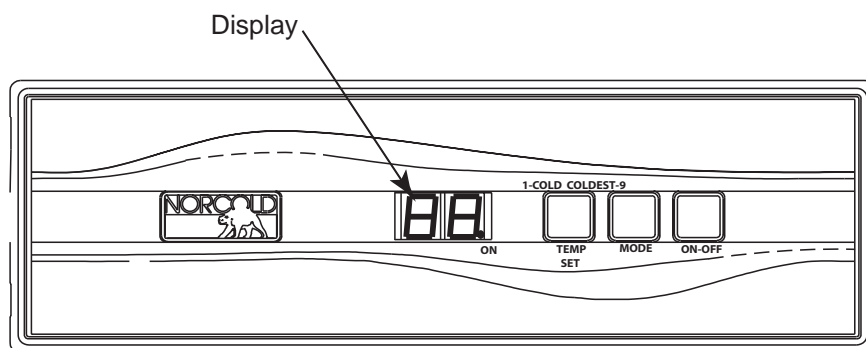

Figure 47. Models N64X/N84X Optical Control Assembly.

Diagnostic Mode

The Diagnostic Mode uses ten diagnostic channels, commonly known as "screens", to display "live" inputs, outputs, and fault history. Each screen is identified by a number, which shows in the optical control assembly display. See Figure 47.

The N64X/N84X optical control display uses a dual 7-segment LED module to display the screen number and diagnostic information. Information made up of four letters or digits displays in an alternating sequence. Fault history, "live" inputs, and outputs is presented using LED segments. The diagnostic LED segments, if present, display to the right of the screen number. Diagnostic LED segments identification numbers. See Figure 48.

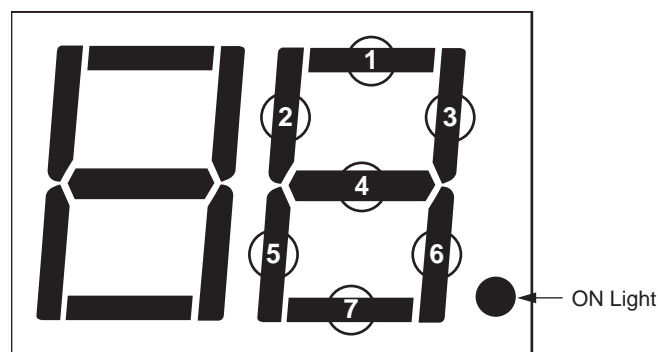









Figure 48. Diagnostic LEDs Segments Identification.

Accessing the Diagnostic Mode

To access the Diagnostic Mode:





1. Press and hold both the  and  buttons **at the same time**.
2. Release the  and  as soon as screen  displays.
3. A few seconds later,  displays.

Changing Screens

To change screens, **press and hold** the  button until the next screen displays.

Exiting the Diagnostic Mode

To exit the Diagnostic Mode:

1. Press and hold  and  buttons **at the same time**.
2. Release the  and  buttons as soon as the display shows .

Turning the refrigerator OFF then back ON also exits the Diagnostic Mode.

Screens and Diagnostic Segments Information

Screen Diagnostic Mode Active

Screen 1 confirms that the Diagnostic Mode is active. A few seconds after the screen number appears, all LED segments light. See illustration.

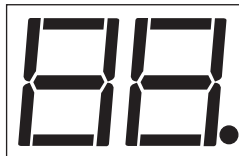

If the screen segments do not match the ones shown in the illustration, the fault is in the optical control assembly. Replacing the optical control should resolve the fault.

Press the  button to bring up screen 2.

Screen LED Segments Reliability Check

Screen 2 diagnostics continue to confirm the reliability of the display. After a few seconds only the ON light displays. All other LED segments should be off. See illustration.

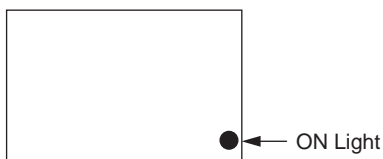

The ON light should be the only LED displayed. If any other LED displays, the fault is in the optical control assembly. Replacing the optical control should resolve the fault.

Press the  button to bring up screen 3.

Screen Thermistor Fin Temperature

Screen 3 displays the actual fin temperature being sensed by the thermistor. **This is not the fresh food cabinet air temperature.** The illustration shows 32°F fin temperature as displayed in screen 3.



Press the  button to bring up screen 4.

Screen Stored Fault History

Screen 4 displays stored fault history using lighted LED segments. The illustration provides fault history information and assigned LED segments. ***If a fault occurred, its assigned fault history LED will be on.***

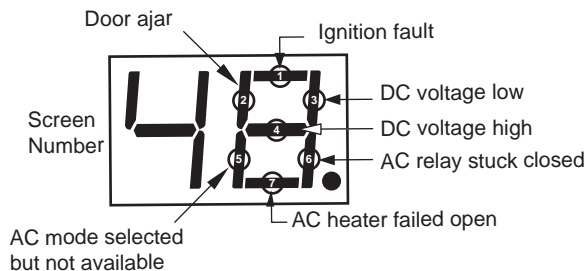

Press the  button to bring up screen 5.

Screen Stored Fault History



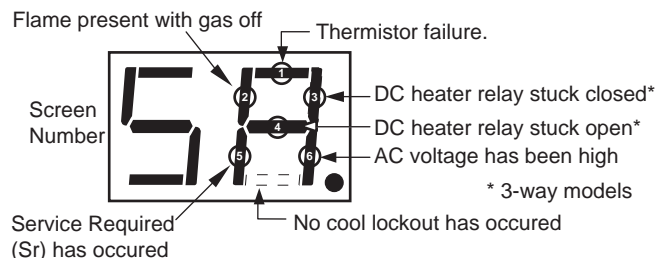

Screen 5 also displays stored fault history using lighted LED segments. The illustration provides fault history information and assigned LED segments. ***If a fault occurred, its assigned fault history LED will be on.***



Press the  button to bring up screen 6.

Screen Erase Fault History

Screen 6 provides a way to erase fault history from memory. To erase fault history:

1. Press and hold the  button when  shows on the screen.
2. Release the  button when  shows on the screen.
3. Wait five seconds.
4. Press and hold the button until  show on the screen.

Press the  button to bring up screen 7.

Screen 7 Power Board Inputs

Screen 7 displays "live" power board inputs using lighted LED segments. The illustration below provides "live" inputs information and assigned LED segments. **If a power board input is active or "live," its assigned input LED will be on.**

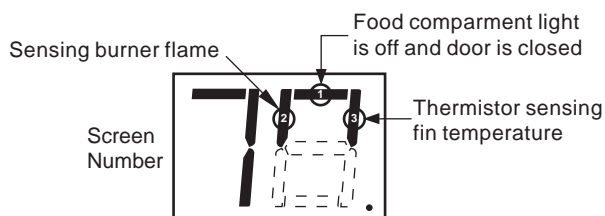

Press the  button to bring up screen 8.

Screen 8 Power Board Outputs

Screen 8 displays "live" power board outputs using lighted LED segments. The illustration below provides "live" outputs information and assigned LED segments. **If a power board output is active or "live," its assigned output LED will be on.**

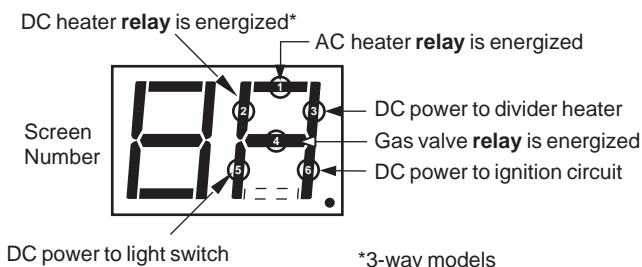

Press the  button to bring up screen 9.

Screen 9 Power Board DC Voltage Status

Screen 9 displays DC voltage status using lighted LED segments. The illustration below provides DC voltage status information and assigned LED segments. **If DC voltage at the power board within normal range (10.5 to 15.4 Vdc), LED segment 4 will be on.**

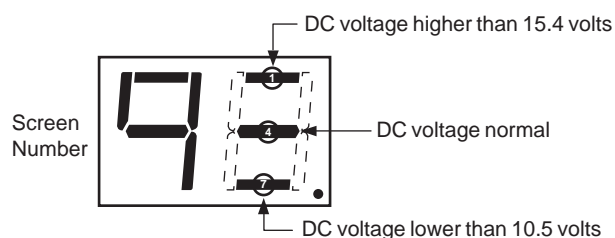

Press the  button to bring up screen 0.

Screen 0 Power Board AC Voltage Status

Screen 0 displays AC voltage status using lighted LED segments. The illustration below provides AC voltage status information and assigned LED segments. **If AC voltage at the power board within normal range (108 to 132 Vac), LED segment 4 will be on.**

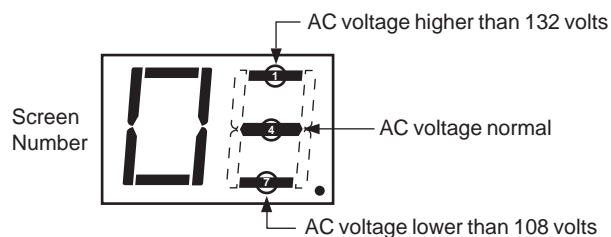

Press the  button to return to screen 1.

ICE MAKER

The ice maker is a factory installed accessory. The components that support the ice maker are the water valve, water fill line, water fill tube, and the wire harness. The ice maker and components are shown in Figure 49.

Wire Harness

The wire harness, Figure 49(a) has four wires.

- Black—line (L) voltage with thermal fuse for ice mold overheating protection. It has an insulated female quick-connect terminal.
- White—neutral (N). The insulated male quick-connect terminal is the 120 Vac neutral (N) conductor .
- Brown—supplies 120 Vac power to the water valve solenoid during the fill cycle. It connects to water valve solenoid \bar{M} terminal.
- Green—ground. Connects to the metal cabinet metal plate along with the 120 Vac power cord ground wire.

Fill Tube

The fill tube is foamed into the top of the cabinet. It is not a replaceable component.

Water Valve

Figure 49(b) shows an ice maker solenoid water valve that has a 12 Vdc water line heater. The 12 Vdc heater is controlled by a thermostatic switch mounted on the valve's mounting bracket.

Figure 49(c) shows an ice maker solenoid water valve without a 12 Vdc water line heater.

Specifications

Cycle.....	One revolution (eject and water fill)
Water fill capacity	4.7 fl. oz. (140 mL)
Ice yield	3.5 lbs/24 hrs. (approximate)
Cycle duration.....	3.5 to 7 minutes
Voltage.....	120Vac
Amp draw	
Cycle on/heater on.....	1.6 A
Cycle on/heater off.....	0.3 A
Cycle off	No amp draw
Motor	1.5 W/8800 Ω
Mold Heater.....	185 W/72 Ω

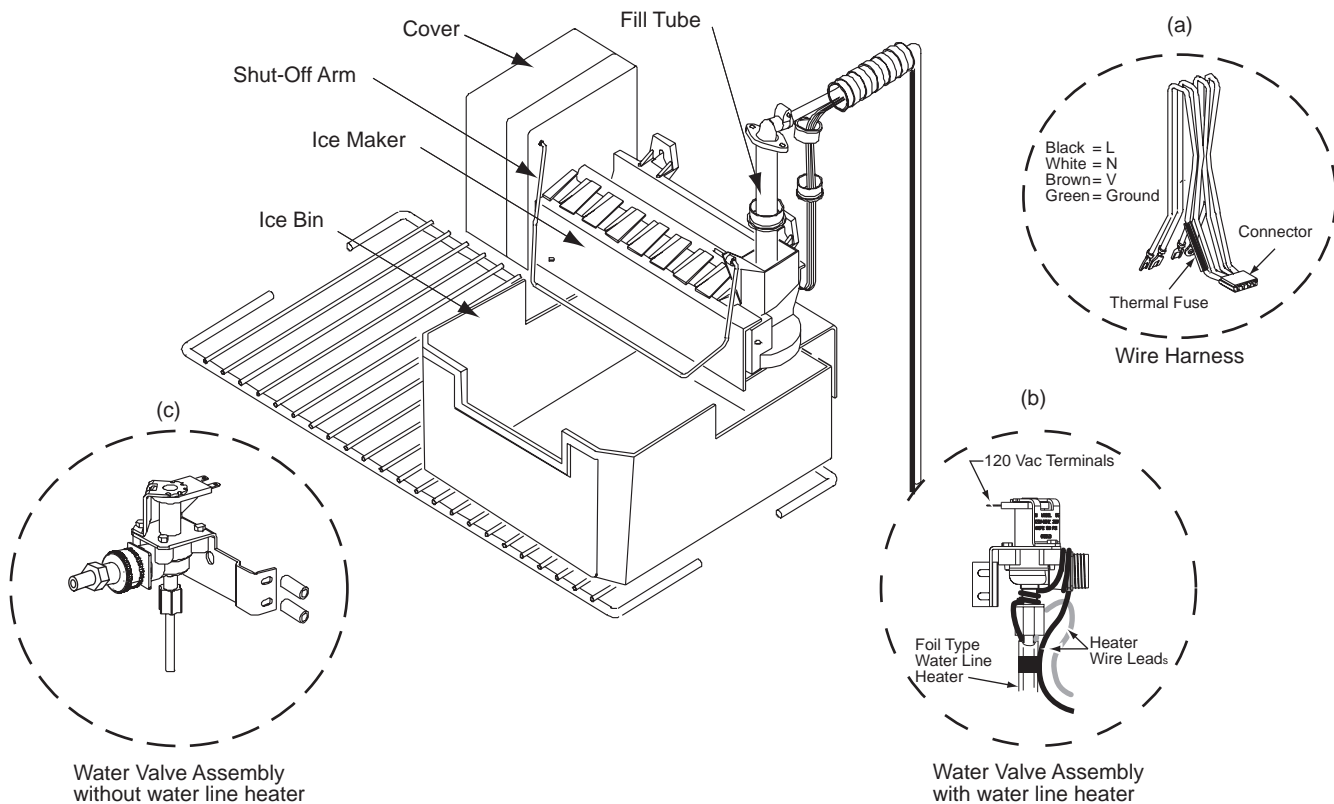

Figure 49. Ice Maker.

Ice Maker Troubleshooting Chart

Problem	Probable Cause	Remedy
<ul style="list-style-type: none"> ■ No ice in mold/no ice yield. 	<ul style="list-style-type: none"> A. No AC power to ice maker B. No water available to ice maker. C. Water valve strainer clogged. D. Water valve failure. 	<ul style="list-style-type: none"> A. Check AC power supply. B. Check water supply to ice maker water. C. Clean water valve inlet strainer. D. Test water valve operation (see page 69).
<ul style="list-style-type: none"> ■ Ice in mold/no ice yield. 	<ul style="list-style-type: none"> A. No AC power available. B. Shut-off arm in the OFF position. C. Mold over filled. D. Water valve washer seal damaged. 	<ul style="list-style-type: none"> A. Check AC power supply. B. Lower the shut-off arm to the ON position. C. Check position of water valve orifice. D. Replace water valve.
<ul style="list-style-type: none"> ■ Mold dripping water/overflowing. 	<ul style="list-style-type: none"> A. Water fill adjustment screw set incorrectly. B. Water valve washer seal damaged. 	<ul style="list-style-type: none"> A. Reset the water adjustment screw. B. Replace water valve
<ul style="list-style-type: none"> ■ Ice maker will not cycle, AC power available. 	<ul style="list-style-type: none"> A. Mold heater failed open. B. Motor failure. C. Mold thermostat failure. D. Wire harness thermal fuse open. 	<ul style="list-style-type: none"> A. See page 68. B. See pages 68 and 69. C. See page 68. D. See page 69.

Replacing the Ice maker

To remove the existing ice maker (see Figure 50):

1. Unplug the refrigerator or ice maker AC power cord from the RV AC power receptacle.
2. Remove the freezer bolts along with the flat washers (two, 1 inch long screws).
3. Remove two upper mounting screws (two, 1/2 inch screws).
4. Unplug the wire harness from the ice maker.
5. Remove two mounting plate screws (two Phillips head screws), then remove the mounting plate.
6. Remove the shut-off arm and install it in the new ice maker.
7. Attach the mounting plate to the bottom of the new ice maker (two Phillips head screws). Tighten screws firmly.
8. Plug the wire harness into the ice maker. Make sure the plug locking tab locks the plug in the connector.
9. Attach the mounting plate to the freezer plate (two, 1 inch long screws with washers)
10. Attach the upper mounting brackets to the freezer plate (two, 1/2 inch screws).

11. Tighten all screws firmly.
12. Plug the AC cord in the RV AC power receptacle.

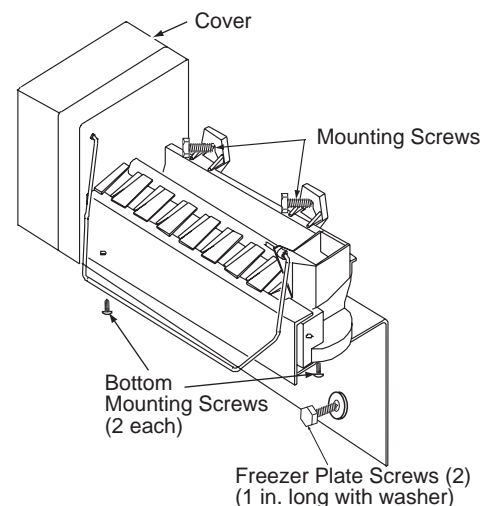

Figure 50. Ice Maker Mounting Hardware.

Cycle Test

Cycle testing the ice maker will confirm if the mold heater energizes and motor complete a full cycle. However, if the ejector fingers are trapped in the ice allow the ice to partially thaw before cycle testing the ice maker.

To cycle test the ice maker:

1. Shut off the water supply to the ice maker water valve.
2. Remove the ice maker cover.
3. Place the shut-off arm in the ON position (down).
4. Make sure 120 VAC is available to the ice maker.
5. Measure voltage across test points L and N. See Figure 51. Voltage reading should be between 108 to 120 Vac. If no voltage present, check the continuity of the ice maker wire harness.

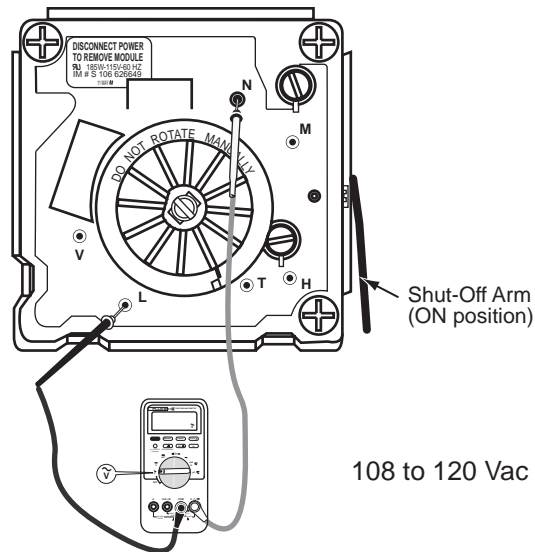

Figure 51. Test points L and N.

NOTE

Shorting test points T and H will start the cycle. Remove the jumper wire from test points T and H when a click sound is heard or immediately after 15 seconds of shorting terminals T and H.



WARNING:

Burn hazard! The mold heater will heat the bottom of the mold. Handle or grasp the ice maker by its sides when performing a cycle test.

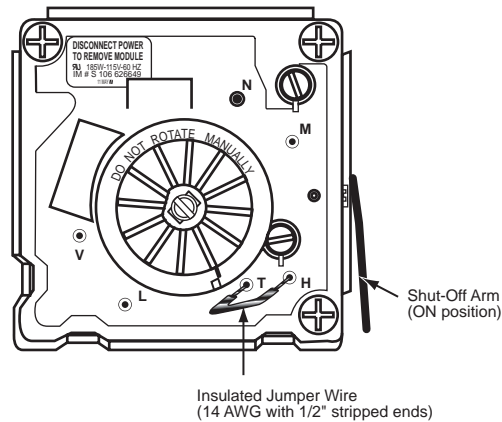

Figure 52. Test points T and H.

6. Short terminals T and H. An insulated jumper wire 14 AWG with 1/2 inch stripped ends is recommended. See Figure 52. The following events should take place during the cycle:

- a. The mold heater begins to heat the mold.
- b. The ice maker ejector starts to cycle.
- c. About 15 seconds into the cycle, the thermostat produces a "click" sound.

NOTE

Remove the jumper wire immediately after hearing the "click" sound or 15 seconds after shorting terminals T and H. Failing to remove the jumper wire will cause damage to the heater and/or overheat the mold, which will ruin the ice maker.

- d. As the ejector fingers reach the 12 o'clock position the water valve energizes.
6. If the water valve does not remain energized between 3.5 and 7.5 seconds, see Water Fill Adjustment, page 70.

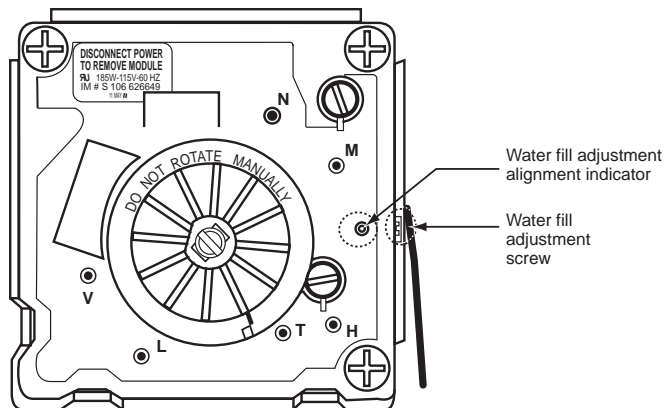

Figure 53. Water Fill Adjustment Screw and Indicator.

Water Fill Adjustment

The ice maker water fill adjustment is factory set. Tampering with the water adjustment screw may cause the water valve to close before the mold is filled to normal level or exceed the mold water level. If the valve closes before the mold is filled to capacity, the ice cubes produced will be small and thin. If the water valve remains open longer than 7.5 seconds, the water level in the mold will be above the normal level. The excess water above the normal level tends to form a layer of ice that fuses all the ice cubes. The surface tension created by the extra layer of ice prevents the ejector from removing the ice cubes from the mold.

The water fill adjustment screw location is shown in Figure 53, page 69. Turning the screw 1/4 turn in a clockwise or counterclockwise direction varies the fill by 0.34 fl. oz. (10 mL).

Turning the screw varies the location of the adjustable internal copper contact. The small hole in the contact should be in the center of the module housing hole (alignment indicator). With the hole centered, the water valve should remain open approximately 7.5 seconds.

Low Ice Yield

The thermostat initiates the cycle when the temperature of the mold is approximately 14°F. For the ice maker mold to reach 14°F, the freezer temperature must be maintained at or below 0°F. In gas absorption refrigerators low ice yield may be caused by poor cooling unit ventilation, which will directly affect freezer temperature.

Water Valve Operation Test

Test water valve operation by shorting points V and L using an insulated jumper wire. See Figure 54. Shorting points V and L energizes the valve's solenoid. When energized, the solenoid will make an audible click and continuous buzzing sound until the jumper wire is removed.

Water Valve Solenoid Resistance

Always disconnect the ice maker AC power cord before taking resistance readings on the water valve solenoid.

To contact test points V and N, the resistance meter's probes must be at least 1/2 inch long. See Figure 55.

- Resistance values: 295 to 360 Ω .
- OL: check for loose wire harness connections at the water valve or an open solenoid coil.
- 00.0 Ω : indicates a short between the ice maker and the water valve.

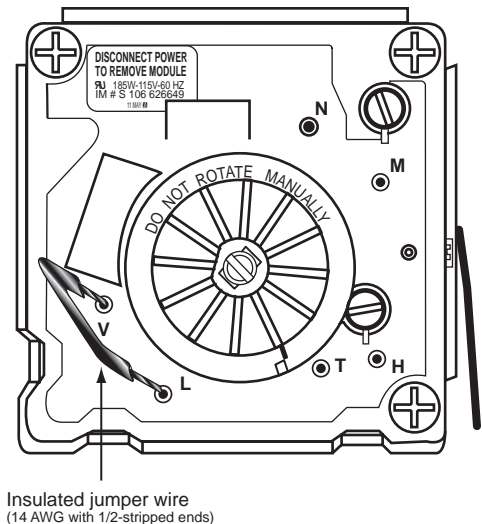

Figure 54. Energizing water valve through test points V and L.

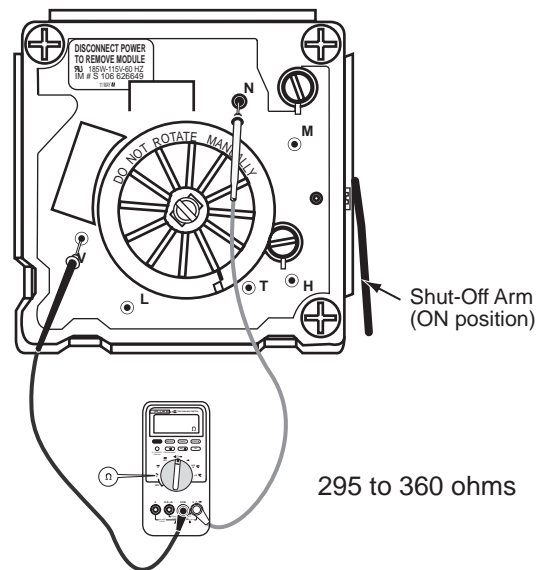

Figure 55. Measuring water valve solenoid resistance across points V and N.

Mold Heater Resistance Check

Unplug the ice maker AC power cord before taking any resistance readings on the ice maker.

To contact test points L and H, the test probes must be at least 1/2 inch long. Connect the multimeter's probes as shown in Figure 56.

- Resistance values: 71 to 79 Ω .
- Replace the ice maker if the mold heater resistance is not within 71 and 79 Ω .

Checking Voltage at Motor Terminals

Make sure AC power is available to the ice maker before taking voltage readings across test points N and M.

To contact test points N and M, the test probes must be at least 1/2 inch long. Figure 57 shows the multimeter connections to points N and M to measure voltage. The voltage across points L and M should be 108 to 132 Vac. If no voltage is detected, make sure replace the ice maker.

Winterizing the Ice Maker Water

To winterize the ice maker:

1. Shut off the RV water supply to the ice maker.
2. Lower the ice maker shut-off arm to the off position.
3. Disconnect the garden hose adapter from the water valve.
4. Disconnect the ice maker water supply line from the water valve. Do not unwrap the water line heater wire from the water valve outlet connection.
5. Allow the water to drain from the RV water supply line and the ice maker water line.
6. Protect connections by bagging and taping RV water supply connection, the ice maker water line connection, and the water valve connections

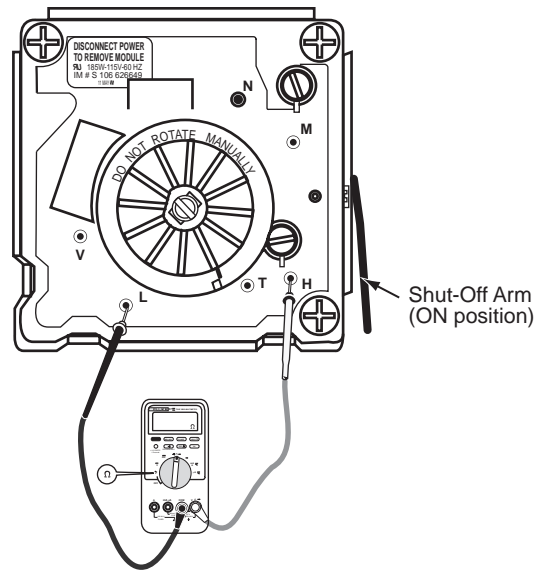

Figure 56. Measuring mold heater resistance across test points L and H.

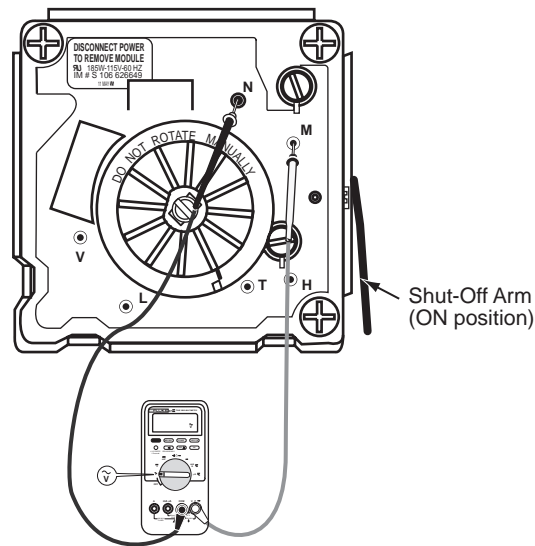
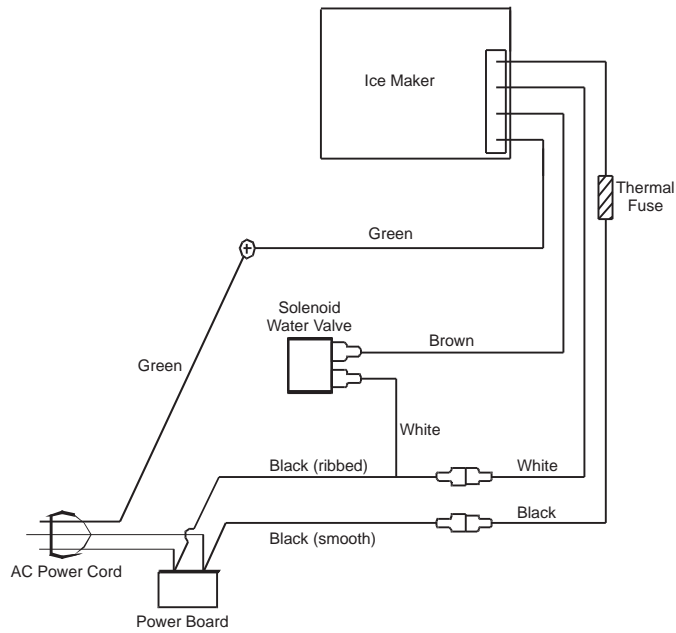
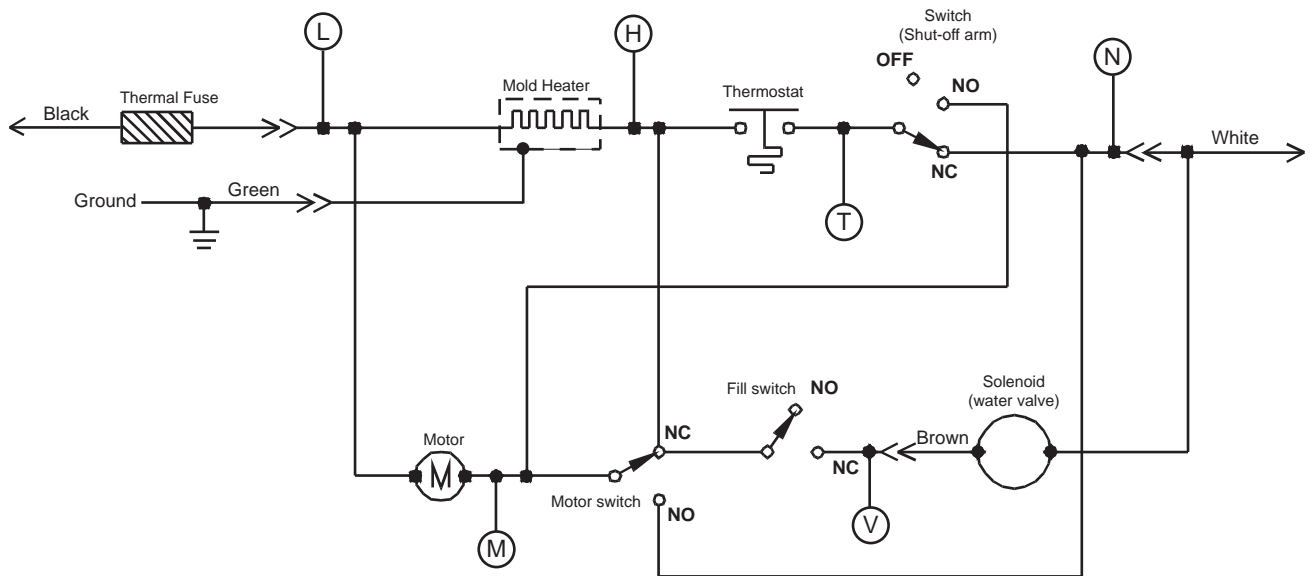

Figure 57. Checking voltage to motor across test points N and M.



N64X IM/N84XIM – Wiring Pictorial for Ice Maker Wired to Refrigerator AC Cord.



N64X IM/N84XIM – Wiring Schematic for Ice Maker Wired to Refrigerator AC Cord.

This page intentionally left blank.



N61X/N81X



N62X/N82X

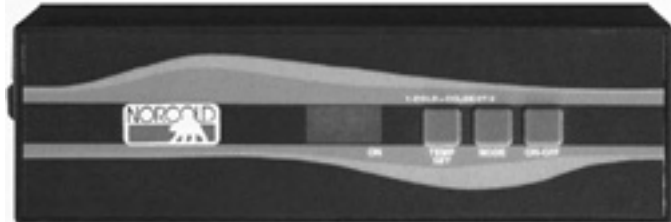

N64X/N84X/N64X.3/N84X.3

NORCOLD®
P.O. Box 4248
Sidney, OH 45365-4248

NORCOLD CUSTOMER SERVICE
Telephone.....1-800-444-7210
Fax937-497-3183
World Wide Web www.norcold.com/cda