



MODELS

NX61 / NX81

NX64 / NX84

NXA64 / NXA84

NX64XIM / NX84XIM

NXA64XIM / NXA84XIM

NX64.3 / NX84.3

NXA64.3 / NXA84.3

WARNING

DO NOT install this refrigerator in below deck marine applications. Do not install this refrigerator in fixed indoor cabin or other dwelling applications. This refrigerator must use only NORCOLD designed and approved outside air intake and exhaust ventilation for correct and safe operation. Any other ventilation could cause lethal combustion exhaust fumes and/or explosive propane gas fumes to be in the living area and/or below deck.

Questions?/Des questions?/¿Preguntas? 1-800-543-1219

CONTENTS

Introduction.....	4	Testing for LP Gas Leaks.....	38
About this Manual.....	4	Components.....	39
Model Identification.....	4	Flame Appearance.....	41
Information Label.....	4	Burner Cleaning Procedure.....	42
Certification and Code Requirements.....	4	Gas Lockout.....	44
About Installation.....	4	Reset a Gas Lockout Condition - All Models.....	44
Replacement Parts.....	4	NX61 / NX81, NX64 / NX84, NXA64 / NXA84 Gas Safety Valve Test:..	44
Technical Assistance.....	4	Electrical Requirements and Components.....	45
Model Identification.....	5	DC Voltage Requirements and Polarity.....	45
Cooling Unit Serial Number.....	5	DC Power Wiring Requirements.....	45
Safety Awareness.....	6	AC/DC Converter as Power Source.....	45
Safety Notice.....	6	AC Power Requirements.....	46
Attention Statements.....	6	12VDC Ventilation Fan.....	47
Safety Statements.....	6	Low Ambient Heater (optional).....	48
Specifications.....	7	Cooling Unit.....	48
NX61 / NX81, NX64 / NX84, NXA64 / NXA84.....	7	Cooling System Monitoring.....	48
Theory of Operation.....	8	Troubleshooting Cooling Faults.....	49
Overview.....	8	Refrigerant Leakage.....	49
Cooling Unit.....	8	Disposal of Cooling Unit.....	49
Leveled Operation.....	8	Cooling System Diagnostic Flowchart.....	50
Gradual Decrease in Cooling Efficiency.....	8	Electrical Requirements and Components.....	52
Gas Absorption System.....	9	Modes of Operation - NX61, NX81.....	54
Electronic Controls.....	10	Start Up:.....	54
Manual AC Mode.....	10	Shut Down:.....	54
Manual LP Gas Mode.....	11	Modes of Operation - NX64 / NX84, NXA64 / NXA84.....	55
Manual DC Mode (3-way models only).....	11	Start Up:.....	55
Auto Mode.....	12	2-way Model Mode Indicators.....	55
Theory of Operation -		3-way Model Mode Indicators.....	55
Auto Modes.....	12	Shut Down:.....	56
Background Operations.....	13	NX64 / NX84, NXA64 / NXA84 Display Codes.....	56
Diagnostic Prechecks.....	15	Ice Maker.....	57
Fault Codes.....	16	Wire Harness.....	57
NX61 / NX81 Fault Codes.....	16	Fill Tube.....	57
Solid Red Indicator Light.....	16	Water Valve.....	57
Fault / Flash Pattern 1 AC Heater Error.....	17	Specifications.....	57
Fault / Flash Pattern 2 Service Error.....	17	Ice Maker Troubleshooting Chart.....	58
Fault / Flash Pattern 3.....		Replacing the Ice Maker.....	58
Open High Limit.....	17	Cycle Test.....	59
Fault / Flash Pattern 4.....		Water Fill Adjustment.....	60
AC Relay Error.....	17	Low Ice Yield.....	60
Fault / Flash Pattern 5.....		Water Valve Operation Test.....	60
Flame On Should Not Be On.....	18	Water Valve Solenoid Resistance.....	60
Fault / Flash Pattern 8.....		Mold Heater Resistance Check.....	61
LOW DC (1) Error.....	18	Checking Voltage at Motor Terminals.....	61
Fault / Flash Pattern 9 LOW DC (2) Error.....	18	Winterizing the Ice Maker Water.....	61
Thermistor Fault.....	19		
Door Fault.....	19		
Blank Display.....	19		
NX64 / NX84, NXA64 / NXA84 Fault Codes.....	22		
Diagnostic Mode - NX64 / NX84, NXA64 / NXA84.....	26		
Screens and Diagnostic Segments Information.....	27		
Ventilation.....	29		
Roof Exhaust Venting.....	29		
Air Intake Vent.....	29		
Roof Exhaust Vent.....	29		
Baffles.....	30		
Vertical Enclosures.....	31		
Double Sidewall Venting.....	35		
Double Side Wall Venting.....	36		
LP Gas System.....	38		
Pressure Requirements.....	38		

Figures

Fig. 1 - Refrigerator Information Label Location 5
 Fig. 2 - Cooling Unit Bar Code Label Location 5
 Fig. 3 - Gas Absorption System 9
 Fig. 4 - Flash Patterns 16
 Fig. 5A - Thermistor 19
 Fig. 5B - Thermistor in Ice 19
 Fig. 6 - NX61 / NX81, NX64 / NX84, NXA64 / NXA84 Continuous 12-Volt 21
 Fig. 7 - NX61 / NX81, NX64 / NX84, NXA64 / NXA84 Switched 12-Volts 21
 Fig. 8 - NX64 / NX84, NXA64 / NXA84 Display Board 26
 Fig. 9 - Diagnostic LEDs Segments Identification 26
 Fig. 10 - Roof Exhaust Venting Arrangement. 29
 Fig. 11 - Rear View-Roof Exhaust Venting 30
 Fig. 12 - Baffles Req. for Inboard Roof Exhaust Vent Installation... 30
 Fig. 13 - Vertical Enclosure Depth of 24 > 26 Inches 31
 Fig. 14 - Vertical Enclosure Depth of 26 > Inches 32
 Fig. 15 - Offset Vertical Enclosure Depth of 24 > 25 Inches 33
 Fig. 16 - Offset Vertical Enclosure Depth of 26 > Inches 34
 Fig. 17 - Double Side Wall Enclosure Depths of 24 > 26 Inches ... 36
 Fig. 18 - Double Side Wall Enclosure Depth of 26 > Inches 37
 Fig. 19 - LP Gas System Components 38
 Fig. 20 - Solenoid Gas Valve 39
 Fig. 21 - LP15 Orifice Assemblies 40
 Fig. 22 - Burner 40
 Fig. 23 - Burner Tube 40
 Fig. 24 - Flue and Components 41
 Fig. 25 - Flue Baffle 41
 Fig. 26 - Flame Appearance 41
 Fig. 27 - Drip Cup and Burner Box Cover 43
 Fig. 28 - Burner and Components 43
 Fig. 29 - DC Heater 45
 Fig. 30 - AC and DC Heaters (3-way refrigerator) 46
 Fig. 31 - Lamp/Thermistor Assembly 46
 Fig. 32 - AC Heater 46
 Fig. 33 - AC Power Cord 47
 Fig. 34 - Fan Mounted on Top of Absorber Coil 47
 Fig. 35 - Fan Thermostat 47
 Fig. 36 - Fan with Installed NORCOLD Fan Kit 48
 Fig. 38 - Wiring Diagram and Pictorial-Low Ambient Heater 48
 Fig. 37 - NORCOLD Fan Kit Wiring Pictorial 48
 Fig. 39 - Reset Pushbutton 48
 Fig. 40 - Cooling System Diagnostics 50
 Fig. 41 - Wiring - NX61 / NX81, NX64 / NX84, NXA64 / NXA84 ... 52
 Fig. 42 - Wiring - NX61 / NX81, NX64 / NX84, NXA64 / NXA84 ... 53
 Fig. 43 - NX61, NX81 Display Board 54
 Fig. 44 - NX64 / NX84, NXA64 / NXA84 Display Board 55
 Fig. 45 - Ice Maker 57
 Fig. 46 - Ice Maker Mounting Hardware 58
 Fig. 47 - Test points L and N 59
 Fig. 48 - Test points T and H 59
 Fig. 49 - Water Fill Adjustment Screw and Indicator 59
 Fig. 50 - Energize water valve through test points V and L 60
 Fig. 51 - Measure water valve solenoid resistance 60
 Fig. 52 - Measure mold heater resistance 61
 Fig. 53 - Check voltage to motor 61
 Fig. 54 - NX64IM / NX84XIM, NXA64IM / NXA84XIM – Ice Maker Wired to Refrigerator AC Cord 62
 Fig. 55 - NX64IM / NX84XIM, NXA64IM / NXA84XIM – Ice Maker Wired to Unit Refrigerator Cord 62

Tables

Table 1: Temperature Set Points NX61 / NX81 14
 Table 2: Temperature Set Points NX64 / NX84, NXA64 / NXA84 14
 Table 3: Clearances for Roof Vented Installations 30
 Table 4: NX61, NX81 Operation Modes 54
 Table 5: NX64 / NX84, NXA64 / NXA84 Operation Modes 55
 Table 6: NX64 / NX84, NXA64 / NXA84 Display Codes 56

INTRODUCTION

About this Manual

This service manual provides maintenance, diagnostic, and repair information for **NORCOLD**® models NX61 / NX81, NX64 / NX84, NXA64 / NXA84 gas absorption refrigerators. It is a reference tool designed for technicians who are knowledgeable in the theory and operation of gas/electric absorption refrigerators, liquefied petroleum (LP) gas–propane–systems, and AC/DC electrical systems as installed in a variety of recreational vehicles (RV).

All information, illustrations, and specifications contained in this publication are based on the latest product information available at the time of publication. **NORCOLD**® reserves the right to make changes at any time without notice.

Model Identification

Models NX61, NX81, NX64, NXA64, NX84 and NXA84 are 2-way refrigerators that operate on AC power or LP gas.

Models NX64.3, NXA64.3 and NX84.3 and NXA84.3 are 3-way refrigerators, that operate on AC power, LP gas, or DC power.

Letter(s) appended to the model number identify factory installed accessories. See Fig. 1.

Information Label

The information label is located in the upper right corner of the fresh food compartment just below the divider. See Fig. 1. The label provides the following information:

- Serial number.
- Model number.
- LP gas (propane) pressure.
- Btu/h.
- AC voltage and amperage.
- DC voltage and amperage.
- Design certification.
- Vent kit requirement.

Certification and Code Requirements

NORCOLD® NX6X / NX8X, NXA6X / NXA8X gas/electric absorption refrigerators are certified under the latest edition of *ANSI Z21.19B* standards for installation in mobile homes or recreational vehicles, and with the Canadian Standards Association *CAN/CGA-1.4-M94*.

Electrical components are  compliant.

About Installation



Refrigerator installation must conform with the *NX6/NX8 Installation Manual* for the **NORCOLD**® limited warranty to be in effect. Installation must also comply with applicable local codes and standards set by the relevant certification agency.

Replacement Parts

Use only authorized **NORCOLD**® replacement parts. Generic parts do not meet **NORCOLD**® specifications for safety, reliability, and performance. The use of unauthorized aftermarket or generic replacement parts voids the refrigerator's limited warranty coverage.

Technical Assistance

If unable to resolve technical issues using the information provided in this manual, technical support is available through **NORCOLD**® Customer Service Center:

	Telephone:	1-800-444-7210
	Fax:	1-734-769-2332
	World Wide Web:	www.norcold.com

The following information is required to process technical support requests; refer to the following page:

- Refrigerator Model Number
- Refrigerator Serial Number
- Refrigerator Cooling Unit Serial Number
- Recreational Vehicle (RV) Make/Model/Year

MODEL IDENTIFICATION

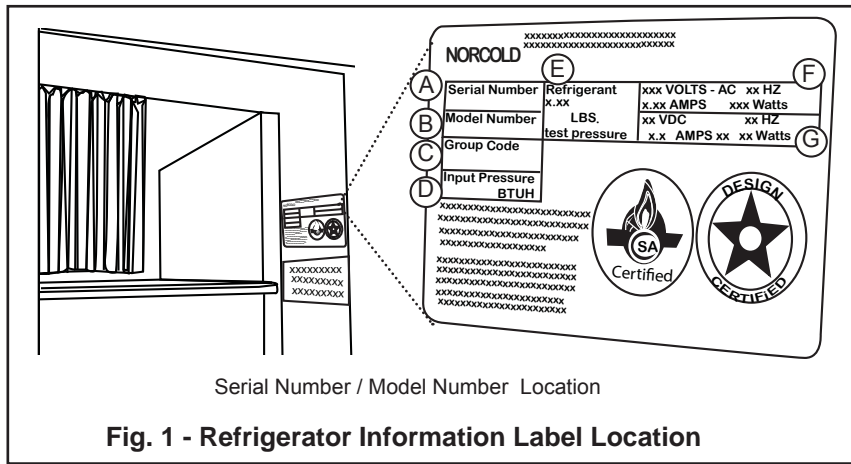

Fig. 1 - Refrigerator Information Label Location

- A. Serial Number
- B. Model Number
- C. Group Code
- D. BTU/h
- E. Amount of refrigerant in cooling unit
- F. AC Voltage/amperage
- G. DC Voltage/amperage

	Explanation
1	N = Norcold
2	X = Sequence number indicating custom features
3	6 or 8 = Approximate storage volume in cubic feet
4	X = Sequence number indicating custom features
5	Models available. Blank = 2-Way operation, .3=3-Way operation
6	Icemaker unit. Blank = does not have ice maker, IM = has icemaker
7	Blank = Is not equipped for low ambient operation, C = Is equipped for low ambient operation
8	Door design: Blank: Insert panel doors, SS: Stainless steal wrapped, BK: Black wrapped, WH: White wrapped, WPM: Pewter Royce wrapped
9	Fan: Blank: No fan, F = Equipped (1) Fan, F2 = Equipped (2) Fans, V = Equipped (1) High Velocity Fan
10	Door swing: L = Left-hand door swing, R = Right-hand door swing
11	P=Black acrylic door panels
12	Packaging Type: Blank: Corrugated packaging, T = Returnable packaging tray, M6 = 6-unit multi-pack

NX6103IMCBKXRP T

Note: The actual refrigerator label specifies the features applicable to that unit.

Cooling Unit Serial Number

The cooling unit serial number appears on the cooling unit bar code label. The label is affixed to the surface of the cooling unit leveling chamber.

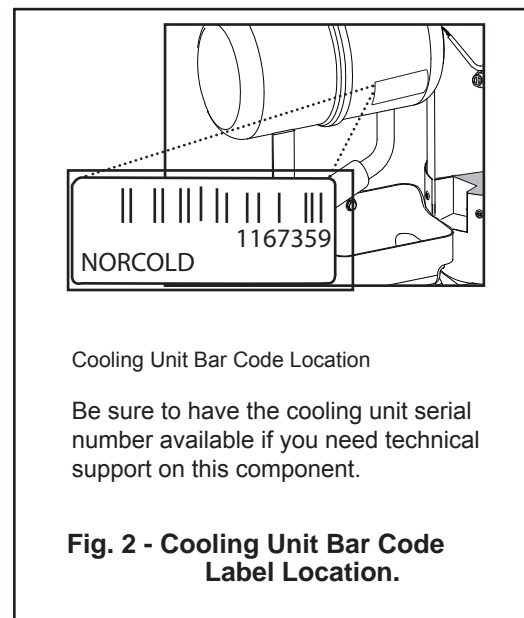

SAFETY AWARENESS

Safety Notice

It is not possible to anticipate all of the conceivable ways or conditions under which the refrigerator may be serviced or to provide cautions as to all of the possible hazards that may result. Standard and accepted safety precautions and equipment should be used when working on electrical circuits and handling toxic or flammable materials. Safety goggles and other required protection should be used during any process that can cause material removal, such as when removing a leaking cooling unit and cleaning components.

Attention Statements

The safety alert symbol  followed by the word **WARNING** or **CAUTION** identifies potential safety hazards or conditions.

The safety alert symbol with the appropriate heading appears on all safety labels posted on the refrigerator and safety awareness notices presented throughout this manual.

WARNING

The above heading identifies hazards or conditions, which if ignored can cause serious injury, death, and/or extensive property damage.

CAUTION

The above heading identifies hazards, which if ignored can cause injury and/or property damage.

Safety Statements

- ▲ **Do not** modify, alter, or equip the refrigerator to the use of any other fuel (natural gas, butane, etc.). NX6X/NX8X, NXA6X, NXA8X refrigerators are designed and equipped for the use of LP gas—*propane gas*—only.
- ▲ Incorrect installation, adjustment, alteration, or maintenance of the refrigerator can cause personal injury, property damage, or both.
- ▲ **Do not** smoke, light fires, or create sparks when working on the propane gas system.
- ▲ **Do not** use an open flame for leak testing any of the propane gas system components. Propane gas is highly flammable and explosive.
- ▲ Always use two wrenches to tighten or loosen LP gas connections. Damaged connections, piping, and components create the potential for gas leaks.
- ▲ All electrical connections and repairs to the refrigerator must comply with all applicable codes. Refer to the certification and code requirements section of the *NX6X/NX8X Installation Manual*.
- ▲ **Do not** work on live electrical circuits. Turn off AC power and DC power sources before attempting to remove, service, or repair any of the refrigerator's electrical or electronic components.
- ▲ **Do not** modify, bypass, or eliminate any of the refrigerator's electrical components, electronic circuits, or propane gas system components.
- ▲ **Do not** wet or spray liquids on or near electrical connections or electronic components. Most liquids, including leak detection solutions, are electrically conductive and pose the potential for an electric shock hazard, short electrical components, damage electronic circuits, and/or ignite a fire.
- ▲ **Do not** use leak test solutions that contain ammonia or chlorine. Ammonia and chlorine degrade copper and brass components.
- ▲ **The cooling unit is a sealed system under pressure! Do not** try to repair or recharge the cooling unit. **Do not** bend, drop, weld, drill, puncture, saw, or strike the cooling unit.
- ▲ **Handle a leaking cooling unit with extreme caution!** The cooling unit contains ammonia, hydrogen, and sodium chromate. Ammonia can cause severe skin and eye burns. Hydrogen is highly flammable, can ignite and burns with an intense flame. Certain chromium compounds, such as sodium chromate, are carcinogenic.
- ▲ **Do not** use extension cords. **Do not** remove the grounding prong from the refrigerator AC power cord. **Do not** use a two prong adapter to connect the refrigerator to the AC outlet.
- ▲ **Do not** over-fuse electrical circuits. Use specified fuses and AWG wire sizes. The specification section of this manual provides fuse size information. Refer to the *NX6X/NX8X Installation Manual* for the correct AWG wire size specifications.
- ▲ **Prevent child entrapment!** Before disposing of the refrigerator, remove all doors and fasten all shelves with retainers.
- ▲ Some of the refrigerator's metal components have sharp corners and edges. Wear hand protection, such as cut resistant gloves, and exercise extreme care when handling the refrigerator.
- ▲ Make sure all hardware such as hinges and fasteners (retaining screws, etc.), are properly fastened.

SPECIFICATIONS

NX61 / NX81, NX64 / NX84, NXA64 / NXA84

NX61 / NX81 - Electronic

- Push Button - On/Off, Mode, and Temperature Set
- LED Indicator Lights
- Self-Diagnostic with Fault Indicators
- 2-Way Operation
- Three Separate Temperature Settings (With Backup Operating System Mode)
- Sleep Mode

NX64 / NX84, NXA64 / NXA84 - Electronic

- Push Button - On/Off, Mode, and Temperature Set
- Backlit LCD (Liquid Crystal Display) with Icon Indicators
- Self-Diagnostic with Fault Codes
- 2-Way Operation (Standard), 3-Way Operation (Optional)
- Nine Separate Temperature Settings (With Backup Operating System Mode)
- 10 Individual Diagnostic Screens
- Sleep Mode

Rough opening dimensions (H x W x D)

NX6XX, NXA6XX	-----	52 7/8 in. x 23 1/2 in. x 24 in.
NX8XX, NXA8XX	-----	59 7/8 in. x 23 1/2 in. x 24 in.

Decorative panels dimensions

Thickness	-----	3/16 in.
Freezer door (H x W, both models)	-----	15 11/16 in. x 21 19/32 in.
Upper panel	-----	15 11/16 in. x 21 19/32 in.
Fresh food compartment (H x W)		
NX61 / NX64 / NXA64	-----	32 25/32 in. x 21 19/32 in.
NX81 / NX84 / NXA84	-----	39 25/32 in. x 21 19/32 in.

DC power

DC input voltage requirements	-----	10.5VDC to 15.4VDC
DC Fuse, F1 on Power Board	-----	Automotive Blade, Type APR-5A-Tan
DC Fuse, F1 on optional DC Board	-----	Automotive Blade, Type APR-30A-Green
DC Heater (Optional)	-----	280W/14VDC, (0.67 Ω to 0.73 Ω), Current \approx 16A to 18A @ 12VDC
Divider Heater	-----	3.1W/12VDC, (43 Ω to 50 Ω), Current \approx 240mA to 279mA @ 12VDC
Gas Valve	-----	1.75W/12VDC, (74 Ω to 92 Ω), Current \approx 130mA to 162mA @ 12VDC
Interior Light	-----	GE #214, Miniature Automotive Light Bulb, 1/2 A @ 13.5VDC

AC power

AC input voltage requirements	-----	108VAC to 132VAC
AC Fuse, F2 on Power Board	-----	AGC Series, 8A, Fast Acting, Glass Tube (1/4 in. x 1-1/4 in.)
AC Heater	-----	300W/120VAC, (46 Ω to 51 Ω), Current \approx 2.3A to 2.6A @ 120VAC

LP gas (propane)

Operating pressure (Input pressure to gas valve)	-----	10.5 in. to 11.5 in. W.C.
Burner rating (Heat output)	-----	1420 Btu/h @ 11 in. W.C.
Burner orifice size	-----	LP15
Gas ignition	-----	Electronic with flame sensing
Electrode tip-to-burner gap	-----	1/8 in. to 3/16 in.

Off-level operating limits

Side-to-side	-----	-3 degrees-maximum
Front-to-back	-----	-6 degrees-maximum

Temperature Sensor ----- Thermistor, Fin mounted (10th fin from the right)

THEORY OF OPERATION

Overview

The NX6X/NX8X MODEL gas absorption refrigerators are comprised of two separate systems that together allow the refrigerator to cool. When performing service it is important to have a basic understanding of each system and their interaction with one another and how this interaction provides for cooling/refrigeration.

These two "systems" are the:

- Cooling Unit
- Refrigerator Controls (Electronic Controls)

Cooling Unit

The cooling unit is a self-contained gravity flow absorption refrigeration system. The refrigerant charge is a solution of water, ammonia, sodium hydroxide, and sodium chromate. In order to produce cooling a precise heat must be applied to the boiler area which in turn initiates a chemical reaction that extracts heat from the freezer and fresh food compartments, thus providing "cooling."

This precise heat is supplied to the cooling unit via heaters and/or a LP gas burner which are controlled by the refrigerators electronic controls. The refrigerant transfers the heat from the freezer and fresh food cabinets to the absorber coils. At the absorber coils the metal surface absorbs the heat and air flow over the external surfaces of the coils carries the heat away. A more detailed description of the absorption process can be found under the heading "Cooling Unit Detailed Description" on the following pages.

A thermal air current created by the rising hot air flows out of the enclosure through either a roof exhaust vent or a sidewall exhaust vent (depending on installation). The flowing air mass passes over the surface of the condenser fins where it absorbs heat transferred from the ammonia vapors flowing through the condenser. The thermal airflow process creates a "chimney effect" that creates a continuous draft of cooling and combustion air. The fresh air drafted by the chimney effect removes rejected heat, supports combustion, and expels the exhaust gases produced by the combustion process. Obstructions, restrictions, or modifications to vents or the enclosure will affect the heat absorption cycle. Poor cooling unit performance may be due to:

- Loose insulation interfering with the ventilation process
- Construction material or debris left in the enclosure
- Insect screen covering vents
- Plastic sheeting covering vents
- Items stored in the enclosure
- Modifications to vents or enclosure
- No roof or sidewall vent openings

Leveled Operation

The circulation of the refrigerant through the cooling unit is accomplished by gravity flow; therefore, the refrigerator must be operated leveled. Off-level operation affects the flow of the refrigerant through the cooling system. The maximum off-level operation limits are:

- 3° (Degrees) from side-to-side
- 6° (Degrees) from front-to-back

Exceeding the maximum off-level limits can permanently damage the cooling unit. The cooling unit or its performance is not affected when the vehicle is in motion.

Gradual Decrease in Cooling Efficiency

A gradual decrease in cooling efficiency is not a clear indication of cooling system failure. Other factors that affect cooling efficiency include ventilation, the heat input, off-level operation, lack of service and maintenance, inadequate repairs, or unauthorized field modifications. If any of these factors exist and are not corrected, a replacement cooling unit will also perform inefficiently or fail. Step-by-step troubleshooting is the best approach when dealing with a gradual decrease in cooling. It is important to consider that, though not efficiently, the cooling unit is working. Troubleshooting should always begin by checking ventilation, then thoroughly checking the cooling unit, and heat sources. In the majority of reported cases, the problem is related to the installation, which in turn hinders cooling unit ventilation. Additionally, ambient air temperature plays a significant role if the unit is not installed correctly. Incorrect installation can lead to poor ventilation, which in turn relates to poor cooling performance.

The unit's service and maintenance history should be considered when checking a cooling unit for poor cooling performance. The service history and the scope of service work performed may lead directly to cause and resolution of a cooling problem. The cooling unit has to reach normal operating temperatures before troubleshooting can take place. It takes an average of four hours for the refrigerant to reach normal operating temperatures. The time frame to reach operating temperatures depends on ambient air temperature.

Gas Absorption System

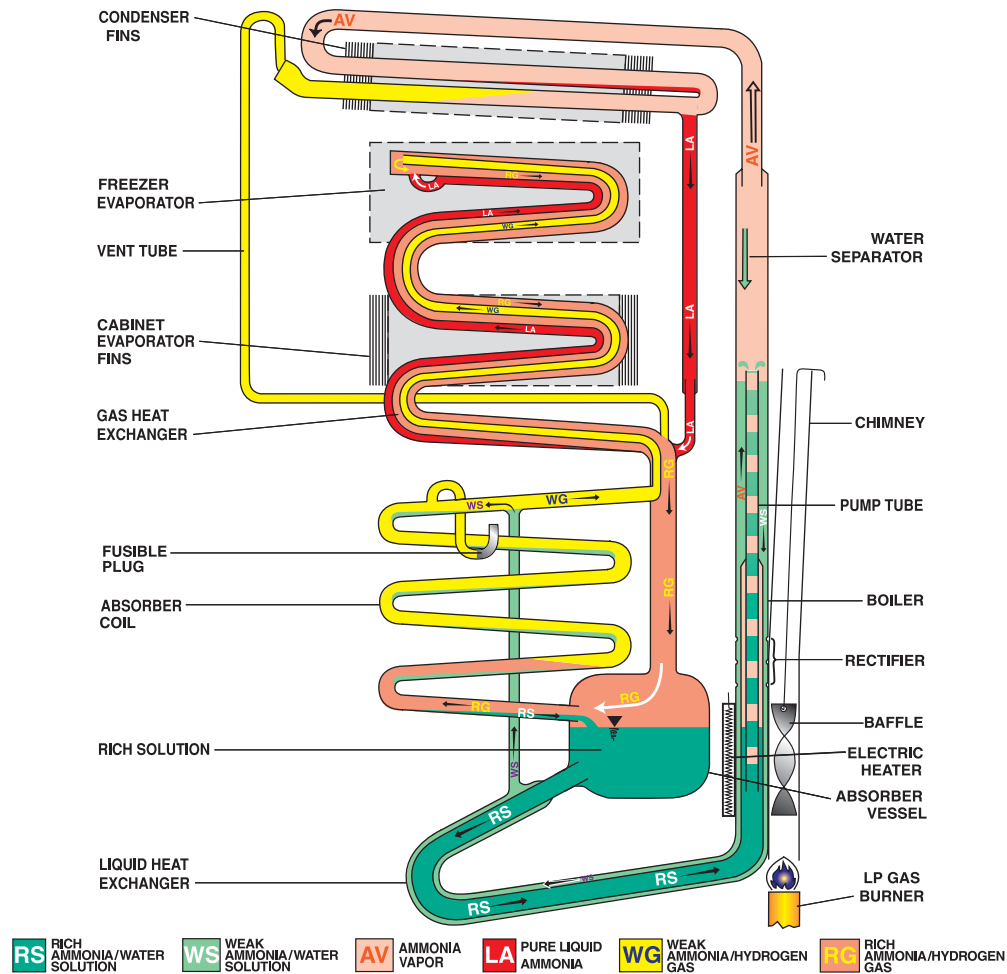

Fig. 3 - Gas Absorption System

A rich solution (RS) leaves the absorber vessel and passes through the liquid heat exchanger to the bottom of the pump tube. Utilizing a cartridge type heater (AC or DC) or a LP gas burner, a precise heat is applied to this area which in turn causes the temperature of the solution to rise. This temperature increase causes ammonia and some water vapor to be driven out of the solution, forming vapor bubbles which push columns of liquid up the pump tube.

As these columns of liquid exit the pump tube the liquid falls downward through the rectifier where the temperature is increased causing additional ammonia vapor to be released. The remaining liquid, now a weak ammonia-water solution (WS), flows through the external shell of the liquid heat exchanger where it transfers its residual heat to the rich solution (RS) and enters the top of the absorber coil at a reduced temperature. The ammonia-water vapor passes through the water separator whose reduced temperature causes any water vapor to condense and drop back down to the boiler mixing with the existing weak solution (WS). The ammonia vapor (AV) rises and enters the condenser where it condenses (liquefies) into pure liquid ammonia (LA). The liquid ammonia, via gravity, drops into the tubular coil of the freezer and cabinet evaporators and wets the internal surface of the tubes.

The weak ammonia-hydrogen gas that was previously released at the top of the absorber coil passes over the wetted surfaces of the evaporator tubing causing the liquid ammonia to evaporate into the hydrogen. The now rich ammonia-hydrogen gas mixture (RG) draws heat from inside the refrigerator. The weight of the hydrogen-ammonia gas mixture (RG) is heavier than that of the weak gas (WG). Consequently, it falls through the gas heat exchanger into the top of the absorber vessel. From this point it enters the bottom of the absorber coil.

The rich ammonia-hydrogen gas mixture (RG) travels up through the absorber and makes contact with the weak solution (WS) traveling down from the top of the absorber. As the weak solution (WS) drops through the absorber it absorbs the ammonia from the rich ammonia-hydrogen gas mixture (RS). The relatively pure hydrogen (WG) exits the top of the absorber coils to the evaporator and the rich solution falls to the bottom of the absorber vessel where the cycle starts again.

Electronic Controls

A precise heat is applied to the boiler area of the cooling unit causing a chemical reaction within the cooling unit that ultimately results in the refrigerator cooling. The heat applied is done so by means of:

- Cartridge type heaters (AC or DC heaters) positioned in heater wells welded to the surface of the boiler
- LP Gas burner positioned below the boiler such that the heat from the flame is directed across the surface of the boiler

These heat sources are turned on/off via the combination of the electronic controls and a temperature sensor located inside the refrigerator fresh food compartment. A temperature setting is set at the electronic controls and as the temperature sensor warms and cools the heat source is turned on/off accordingly. This process of turning on/off the heat source(s) can be accomplished in various operating modes. These operating modes are:

- Manual AC Mode - While operating in this mode the AC cartridge type heater is operated to provide heat to the boiler area of the cooling unit (2-way & 3-way models)
- Manual LP Gas Mode - While operating in this mode the LP Gas burner is operated to provide heat to the boiler area of the cooling unit (2-way & 3-way models)
- Manual DC Mode - While operating in this mode the DC cartridge type heater is operated to provide heat to the boiler area of the cooling unit (3-way models only)
- Auto Mode - While operating in this mode the electronic control will automatically select the mode to be utilized. It will attempt to operate the heat source requirements in the following order of priority (All models):
 - 1st Priority Choice - AC Electric (AC cartridge type heater)
 - 2nd Priority Choice – LP gas (LP Gas Burner)
 - 3rd Priority Choice – (3-way models only) - DC Electric (DC cartridge type heater)

Dependent upon the model number NX6X/NX8X refrigerators are either considered 2-way or 3-way model refrigerators (See Model Identification section of this manual). 2-way refrigerators are capable of operating priority choices 1 and/ or 2 via separate Manual Modes or an Automatic Mode. 3-way refrigerators are capable of operating all 3 priority choices via separate Manual Modes or an Automatic Mode.

The mode of operation and temperature setting is selected via the optical display assembly located on the front of the refrigerator. A thermistor is mounted on the fin assembly located inside the fresh food compartment. The thermistor acts as a temperature sensor, reporting the temperature sensed to the optical display. The optical display then relays this information to the power board that then turns on/off the appropriate heat source accordingly. The optical display board, power board, thermistor, and other components within the refrigerator are interconnected via a wire harness.

Manual AC Mode

To operate in the Manual AC mode the optical display must be placed to operate in this mode. Once done so, the refrigerator will cool via the AC mode and ONLY the AC mode. While in the AC mode the refrigerators electronic controls will function as follows:

The power board is responsible for:

- Measuring the AC input voltage
- Measuring the AC heater current
- Measuring the resistance value of the thermistor
- Turning ON/OFF the AC heater output
- Communicating with the Optical Display Board

The optical display board is responsible for:

- Determining if the AC input voltage is available or not available
- Determining if the AC heater current is acceptable or not acceptable
- Determining if the thermistor value is above or below preset temperature range cut-in/cut-out values
- Determining when the power board is to turn ON/OFF the AC heater output
- Communicating with the Power Board

Theory of Operation - Manual AC Mode

AC voltage is applied to the power board via the AC power cord at terminals L1 (Hot) and L2 (Neutral). This AC voltage passes through the AGC Series, 8A, Fast Acting, Glass Tube Fuse (F2) where it is then measured. This measurement is communicated to the optical display board which determines if the applied voltage is below or above 85VAC. If the voltage is above 85VAC, the determination is that AC voltage is available. If not, it is determined that AC voltage is not available and the appropriate voltage related fault will be displayed on the optical display.

- NX61 / NX81 = Power ON indicator is Solid RED
- NX64 / NX84 = "no AC" with audible alarm/beeper
- NXA64 / NXA84 = "no AC" with audible alarm/beeper

The power board also measures the thermistor value and reports it to the optical display board. The thermistor, a temperature device whose internal resistance goes down as the temperature goes up, is connected to the power board via terminals P2-1 and P2-6. The optical display board compares the actual thermistor value to preset cut-in and cut-out temperature values for each of the particular temperature settings. Should the thermistor value fall below a particular cut-in value it will request the power board to turn ON the AC heater relay (K2). Should the thermistor value go above a particular cut-out value it will request the power board to turn OFF the AC heater relay.

Any time relay K2 is turned ON, AC voltage is applied to the AC heater via the now closed K2-contacts. Any time AC voltage is applied to the AC heater, an AC current is produced.

This AC current is measured by the power board and its value is passed on to the optical display board. The optical display board determines if the AC current is or is not within the specified limitations. Should the current fall below ½ ampere, the optical display board will display the appropriate AC current related fault.

- NX61 / NX81 = Power ON indicator light flashes RED once, OFF for 5-seconds, repeats
- NX64 / NX84 = "AC HE" with audible alarm/beeper
- NXA64 / NXA84 = "AC HE" with audible alarm/beeper

Manual LP Gas Mode

To operate in the Manual LP Gas mode the optical display must be placed to operate in this mode. Once done so, the refrigerator will cool via the LP Gas mode and ONLY the LP Gas mode. While in the LP gas mode the refrigerators electronic controls will function as follows:

The power board is responsible for:

- Measuring the resistance value of the thermistor
- Determining the presence of a flame
- Turning ON/OFF the gas valve output
- Turning ON/OFF the igniter output
- Communicating with the Optical Display Board

The optical display board is responsible for:

- Deciding if the thermistor value is above or below preset temperature range cut-in/cut-out values
- Deciding when to turn ON and OFF the gas valve
- Communicating with the Power Board

Theory of Operation - Manual LP Gas Mode

The power board measures the thermistor value and reports it to the optical display board. The thermistor, a temperature device whose internal resistance goes down as the temperature goes up, is connected to the power board via terminals P2-1 and P2-6. The optical display board compares the actual thermistor value to preset cut-in and cut-out temperature values for each of the particular temperature settings. Should the thermistor value fall below a particular cut-in value the optical display will request the power board to turn ON the gas valve relay (K1) and high voltage transformer (T1) outputs.

Anytime relay K1 is turned ON, 12VDC passes through the now closed K1 contacts to terminal P1-10 of the power board and out to the gas valve solenoid, energizing the gas valve. With the gas valve energized LP gas flows out to the burner tube. Simultaneously, energy pulses from the high voltage transformer (T1) are carried out to the burner via the spark sense electrode wire. As the energy pulses reach the end of the electrode they jump across the gap between the electrode and the burner creating sparks. The sparks ignite the LP gas and a flame is established. Via the flame rectification process a signal is then sent back to the power board through the spark sense electrode wire letting the power board know there is a flame present.

Knowing a flame is present; the power board deactivates the spark output. At the same time; the power board communicates to the display letting it know a flame is now present. When the thermistor value reaches a particular cut-out value the optical display will request the power board to turn OFF the gas valve output, allowing the flame to extinguish.

If for some reason the flame goes away while there is a call for cooling, at the request of the optical display board, the power board will turn the high voltage transformer back on in an attempt to re-ignite the propane. For safety reasons the sparking at the burner will last for a maximum of 30 seconds, at which time the gas valve/high voltage transformer outputs will be turned off and an error will be displayed via the optical display indicating a gas lockout condition. To reset this gas lockout condition the controls must be powered off/on.

- NX61 / NX81 = Power ON indicator is SOLID RED
- NX64 / NX84 = "no FL" with audible alarm/beeper
- NXA64 / NXA84 = "no FL" with audible alarm/beeper

Manual DC Mode (3-way models only)

To operate in the Manual DC mode the optical display must be placed to operate in this mode. Once done so, the refrigerator will cool via the DC mode and ONLY the DC mode. While in the DC mode the refrigerator electronic control will function as follows:

The power board is responsible for:

- Measuring the resistance value of the thermistor
- Communicating with the Optical Display Board
- Communicating with the DC Board

The optical display board is responsible for:

- Determining if the thermistor value is above or below preset temperature range cut-in/cut-out values
- Determining when the DC board is to turn ON/OFF the DC heater output
- Communicating with the power board
- Communicating with the DC board

The DC board is responsible for:

- Turning ON/OFF the DC heater output
- Measuring the DC heater current
- Communicating with the Optical Display Board
- Communicating with the Power Board

Theory of Operation - Manual DC Mode (3-way models only)

The power board measures the thermistor value and reports it to the optical display board. The thermistor, a temperature device whose internal resistance goes down as the temperature goes up, is connected to the power board via terminals P2-1 and P2-6. The optical display board compares the actual thermistor value to preset cut-in and cut-out temperature values for each of the particular temperature settings. Should the thermistor value fall below a particular cut-in value the optical display will request the DC board to turn ON the DC heater relay (K1) on the DC board.

Should the thermistor value go above a particular cut-out value it will request the DC board to turn OFF the DC heater relay. Any time relay K1 of the DC board is turned ON, DC voltage passes through the 30A, automotive style, SAE J1284 fuse (F1 on the DC board), through the now closed K1-contacts, and on out to the DC heater via DC board terminals DC_HTR and HTR_GND. Any time DC voltage is applied to the DC heater, a DC current is produced. This DC current is measured by the DC board and its value is passed on to the optical display board. The optical display board determines if the DC current is or is not within the specified limitations. Should the current fall below the specified limits the optical display board will display the appropriate DC current related fault.

- NX64.3 / NX84.3 = "dc HE" with audible alarm/beeper
- NXA64.3 / NXA84.3 = "dc HE" with audible alarm/beeper

Auto Mode

To operate in the Auto mode the optical display must be placed to operate in this mode. Once done so, 2-way model refrigerators will cool via the Auto AC mode or Auto LP Gas mode and (3-way models) via the Auto AC mode, Auto LP Gas mode, or the Auto DC mode. While in the Auto mode the refrigerators electronic controls will function as follows:

The power board is responsible for:

- Measuring the AC input voltage
- Turning ON/OFF the AC heater output
- Measuring the AC heater current
- Turning ON/OFF the gas valve output
- Turning ON/OFF the igniter output
- Determining the presence of a flame
- Communicating with the Optical Display Board
- Communicating with the DC Board (3-way models only)

The optical display board is responsible for:

- Determining if the AC input voltage is available or not available
- Determining if the AC heater current is acceptable or not acceptable
- Determining if the thermistor value is above or below preset temperature range cut-in/cut-out values
- Determining when the power board is to turn ON/OFF the AC heater output
- Determining when to turn ON and OFF the gas valve
- Determining when to turn ON/OFF the DC heater output
- Communicating with the Power Board
- Communicating with the DC Board (3-way models only)

The DC board (3-way models only) is responsible for:

- Turning ON/OFF the DC heater output
- Measuring the DC heater current
- Communicating with the Optical Display Board
- Communicating with the Power Board

Theory of Operation - Auto Modes

AC voltage may or may not be applied to the power board via the AC power cord at terminals L1 (Hot) and L2 (Neutral). This AC voltage will pass through the AGC Series, 8A, Fast Acting, Glass Tube Fuse (F2) where it is then measured. This measurement is communicated to the optical display board which determines if the applied voltage is below or above 85VAC. If the voltage is above 85VAC the determination is that AC voltage is available and the optical display board will request the power board to operate via the Auto AC Mode. If the voltage is below 85VAC the determination is that AC voltage is NOT available and the optical display board will automatically default to the Auto LP Gas Mode and request the power board to operate via the Auto LP Gas Mode (see below). If the control is not able to establish a flame while operating in the Auto LP Gas Mode the optical display board will:

2-WAY MODELS:

Automatically default back to the Auto AC mode and wait for AC voltage to return, displaying the following fault code

- NX61 / NX81 Models: Solid RED power indicator light
- NX64 / NX84 Models: "no AC" "no FL" with audible alarm/beeper
- NXA64 / NXA84 Models: "no AC" "no FL" with audible alarm/beeper

3-WAY MODELS:

Automatically default to the Auto DC mode and request the DC board to operate via the Auto DC mode.

Auto AC Mode

When operating in the Auto AC mode the power board measures the thermistor value and communicates it to the optical display board. The thermistor, a temperature device whose internal resistance goes down as the temperature goes up, is connected to the power board via terminals P2-1 and P2-6. The optical display board compares the actual thermistor value to preset cut-in and cut-out temperature values for each of the particular temperature settings. Should the thermistor value fall below a particular cut-in value it will request the power board to turn ON the AC heater relay (K2). Should the thermistor value go above a particular cut-out value it will request the power board to turn OFF the AC heater relay.

Anytime relay K2 is turned ON, AC voltage is applied to the AC heater via the now closed K2 contacts. Anytime AC voltage is applied to the AC heater, AC current is produced. This AC current is measured by the power board and its value communicated to the optical display board. The optical display board determines if the AC current is within specified limitations. If below the minimum specified limit, the optical display board will automatically default to the Auto LP Gas Mode and request the power board to operate via the Auto LP Gas Mode. AC related faults (Voltage or Current) are not displayed while operating in the Auto Mode of operation.

Auto LP Gas Mode

When operating in the Auto LP Gas mode the power board measures the thermistor value and communicates it to the optical display board. The thermistor, a temperature device whose internal resistance goes down as the temperature goes up, is connected to the power board via terminals P2-1 and P2-6. The optical display board compares the actual thermistor value to preset cut-in and cut-out temperature values for each of the particular temperature settings. Should the thermistor value fall below a particular cut-in value the optical display board simultaneously requests the power board to turn ON gas valve relay (K1) and high voltage transformer (T1) outputs.

Anytime relay K1 is turned ON, 12VDC passes through the now closed K1 contacts to terminal P1-10 of the power board and out to the gas valve solenoid, energizing the gas valve. With the gas valve energized LP gas flows to the burner tube. Simultaneously, energy pulses from the high voltage transformer (T1) are carried out to the burner via the spark sense electrode wire. As the energy pulses reach the end of the electrode they jump across the gap between the electrode and the burner creating sparks. The sparks ignite the LP gas and a flame is established.

Via the flame rectification process a signal is then sent back to the power board through the spark sense electrode wire letting the power board know there is a flame present. Knowing a flame is present; the power board deactivates the spark output. At the same time; the power board communicates to the display letting it know a flame is now present.

When the thermistor value reaches a particular cut-out value the optical display will request the power board to turn OFF the gas valve output, allowing the flame to extinguish. If for some reason the flame goes away while there is a call for cooling, the power board will turn the high voltage transformer back on and attempt to re-ignite the propane. For safety reasons the sparking at the burner (trial for ignition time) will last a maximum of 30 seconds, at which time the gas valve/high voltage transformer outputs will be turned off and the LP Gas mode will be locked out.

2-way models will automatically default back to the Auto AC mode and wait, indefinitely, for AC voltage to return. The optical display board will display:

- NX61 / NX81: Solid RED power indicator light
- NX64 / NX84: "no AC" "no FL" with audible alarm/ beeper
- NXA64 / NXA84: "no AC" "no FL" with audible alarm/beeper

3-way models will automatically default to the Auto DC mode and request the DC board to operate via the Auto DC Mode.

Auto DC Mode (3-way models only)

When operating in the Auto DC mode the power board measures the thermistor value and communicates it to the optical display board. The thermistor, a temperature device whose internal resistance goes down as the temperature goes up, is connected to the power board via terminals P2-1 and P2-6. The optical display board compares the actual thermistor value to preset cut-in and cut-out temperature values for each of the particular temperature settings. Should the thermistor value fall below a particular cut-in value the optical display board requests the DC board to turn ON DC heater relay (K1).

Should the thermistor value go above a particular cut-out value it will request the DC board to turn OFF the DC heater relay. Anytime relay K1 on the DC board is turned ON, 12VDC passes through the now closed K1 contacts to terminal DC_HTR of the DC board and out to the DC heater. Any time DC voltage is applied to the DC heater, DC current is produced. This DC current is measured by the DC board and its value communicated to the optical display board. The optical display board determines if the DC current is within specified limitations. If below the minimum specified limit, the optical display board will display:

- NX64.3 / NX84.3: "dc HE" with audible alarm/beeper
- NXA64.3 / NXA84.3: "dc HE" with audible alarm/beeper

Background Operations

Interior Light / Door Switch

The interior-light/door switch is a normally open reed switch that is an integral component of the optical display board.

Theory of Operation - Interior Light / Door Switch

The magnetic pull from a permanent magnet located underneath the top door trim maintains the reed switch (N) contacts closed (light off) when the door is fully closed. Opening the door breaks the magnetic pull, which in turn causes the reed switch contacts to open (light on). The optical display board senses the reed switch contacts are open and in turn:

- Requests that the power board turn ON the K4 relay. Anytime relay K4 on the power board is turned ON, 12VDC passes through the now closed K4 contacts to terminal P1-7 of the power board and out to the interior light.
- Initiates a 2-minute timer that once timed out requests the power board to turn off the K4 relay. This prevents the interior light from being left on in the event the door is not completely shut. NX64/ NX84, NXA64 / NXA84 model refrigerators will also display: "dr" with an audible alarm/beeper.



Note: Anytime the door is sensed open the divider heater output will be turned off.

Moisture Reduction Heater (Divider Heater)

The divider heater is a low wattage heater used to reduce/eliminate sweating on the surface of the plastic area between the freezer and fresh food compartments, i.e. the divider area. Due to the cooling nature of the refrigerator, the divider area, especially on hot humid days, tends to be cooler than that of the air around it. This causes the divider surface to be below the dew point of the surrounding air and as a result moisture or sweating develops. The divider heater, which is not replaceable because it is foamed into place, consists of a resistance wire placed atop one side of an adhesive backed piece of foil adhered to the back of the divider area. Applying 12VDC to the resistance wire causes the wire to warm up. As the wire warms up heat is transferred throughout the area of the foil and subsequently the divider area. The added heat to the divider area keeps the surface temperature above the dew point of the surrounding air thus eliminating the occurrence of sweating.

Theory of Operation - Moisture Reduction Heater (Divider Heater)

The divider heater is connected between the power board at P1-8 and the optical display board at P1-5. When the refrigerator is first powered on the power board measures the value of the DC input voltage and communicates this value to the optical display board. Providing the value of the DC input voltage is greater than 10.5VDC the optical display board will request the power board to turn ON relay K5. Anytime relay K5 on the power board is turned ON, 12VDC passes through the now closed K5 contacts to terminal P1-8 of the power board and out to one side of the divider heater. The other side of the divider heater is tied to 12 volt ground via the white/violet wire connected between P1-4 of the optical display and P2-4 of the power board. Anytime the optical display senses the door is open, it requests the power board to turn off K5. Once the door is closed the optical display will request the power board to turn K5 back on. Anytime the DC input voltage falls below 10.5VDC the optical display will request the power board to turn off K5. Anytime K5 is turned off due to low DC voltage it will not be turned back on until the DC input voltage has gone above 11.5VDC.

Backup Operating System (BOS) Mode

The refrigerator has the ability to continue cooling in the event the thermistor (temperature sensor) becomes inoperable. Should the thermistor become electrically open or shorted the electronic controls will revert to this backup operating mode, allowing the refrigerator to continue cooling until it can be serviced.

Temperature set points and BOS duty cycles for each model are as follows:

NX61 / NX81 MODELS			
Temperature Setting	Cooling Cycle		
	On Time (Minutes)	Duty Cycle (%)	Off Time (Minutes)
Cold	12	20	48
Colder	36	60	24
Coldest	60	100	0

Table 1: Temperature Set Points NX61 / NX81

NX64 / NX84, NXA64 / NXA84 MODELS			
Temperature Setting	Cooling Cycle		
	On Time (Minutes)	Duty Cycle (%)	Off Time (Minutes)
1	12	20	48
2	18	30	42
3	24	40	36
4	30	50	30
5	36	60	24
6	42	70	18
7	48	80	12
8	54	90	6
9	60	100	0

Table 2: Temperature Set Points NX64 / NX84, NXA64 / NXA84**Theory of Operation - Backup Operating System (BOS) Mode**

The power board measures the thermistor value and communicates it to the optical display board. Should it sense the thermistor is inoperable (electrically shorted/open, unplugged, damaged, etc.) the optical display board will activate the BOS mode. While operating in the BOS mode the thermistor will be ignored and the temperature set point will be interpreted as a duty cycle instead of a temperature setting. This duty cycle will maintain refrigerator cooling by controlling the length of time the heat source outputs (AC heater, LP burner, or DC heater) are energized. The duty cycle, or length of time the cooling cycle is regulated, can be manually controlled via the TEMP SET button. When a colder temperature is desired, changing the temperature setting to the next "colder" setting will provide additional cooling by lengthening the cooling cycle. When a warmer temperature is desired, changing the temperature setting to a warmer setting shortens the cooling cycle. The cycle period is 1 hour, giving a minimum ON time of 12 minutes.

Defrost Operation

Although the refrigerator is NOT frost free, it is designed to limit frost build up on the fresh food fins (metal fins mounted on the back wall of the fresh food compartment). This is done by simply turning off the heat source output, which in turn, momentarily suspends cooling. As the fin temperature rises, the frost melts.

Theory of Operation - Defrost Operation

Every 49 hours of operation the refrigerator will enter a defrost mode. While in the defrost mode the power board monitors the thermistor value, reporting it to the optical display board. If the thermistor value is greater than 38°F the optical display will exit the defrost mode, reset the 49 hour timer, and continue normal operation. If the thermistor value is less than 38°F the optical display will request that the power board turn OFF the applicable heat source output, be it one of the AC/DC heaters or the LP gas burner, until the thermistor value reaches 38°F. Once the 38°F requirement is met the optical display will exit the defrost mode, reset the 49 hour timer, and continue normal operation.

Auxiliary Output

The auxiliary output is used to power auxiliary loads such as a fan or waterline heater. The voltage at this output is whatever the DC input voltage connected to power board terminals 12VDC and GND is. That is to say, if the DC input voltage to the refrigerator is 11VDC then the auxiliary output voltage will be 11VDC.

Theory of Operation - Auxiliary Output

When the ON button of the optical display board is pressed, relay K3 on the power board is turned ON; see On-Off Theory of Operation for detailed explanation. Anytime relay K3 is ON, the DC input voltage connected at the refrigerator (terminal P1-5 of the power board) passes through the now closed K3 contacts to terminal P1-3 of the power board. The DC ground connection (terminal GND) is electrically tied to power board terminal P1-3. This auxiliary output will be present anytime the refrigerator is ON.

DIAGNOSTIC PRECHECKS

Prior to performing the diagnostic steps called out in the following pages; first verify these four important diagnostic pre-checks. In most cases doing so, in and of itself, will remedy the problem at hand.

1. The refrigerator is plugged into a known working AC outlet with a voltage between 108VAC and 132VAC
2. Extension cords are not being used to supply AC power to the refrigerator
3. The refrigerator is connected to a known working DC power supply and/or battery supplying between 10.5 and 15.4VDC
4. LP gas is available to the refrigerator and is regulated between 10.5 and 11.5"WC (Inches of Water Column)

FAULT CODES

NX61 / NX81 Fault Codes

The NX61/NX81 model refrigerators have the ability to recognize various fault conditions and will display a unique error/fault code accordingly. With the exception of the thermistor fault which is displayed by flashing the cold setting snowflake on and off (while the optical display is awake), all fault codes are displayed via the power ON indicator and will be RED in color.

Should the selected heat source input for a particular mode not be available, the power ON indicator light will be ON continuously. In other words, the power ON indicator will be solid RED.

Solid Red Indicator Light

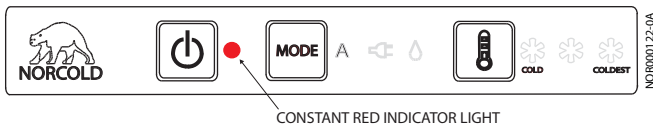

The following conditions will cause the power ON indicator to be solid RED:

Manual AC Mode:

The AC input voltage to the refrigerator was sensed to be less than 85VAC

Verify:

- The refrigerator is plugged into a known working AC outlet supplying a minimum of 85VAC
- The AC power cord is in good operating condition
- The glass 8-amp fuse (F2) on the Power Board is intact
- Replace Power Board.

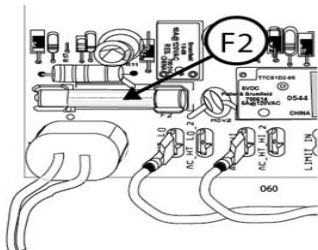

Manual LP Mode:

A flame was NOT established or a flame was NOT sensed

Verify:

- All LP gas shutoff valves (including manual shutoff on gas valve itself) are open
- LP Gas pressure at refrigerator is 11.5" W.C. (water column)
- LP gas supply line is free of air
- The burner is clean
- The electrode-to-burner air gap is between 1/8" and 3/16"
- The spark-sense igniter wire is installed correctly and in good operating condition / continuity
- Gas valve solenoid is in good operating condition (Coil resistance $\approx 74\Omega$ to 92Ω)
- Wires to the gas valve are connected and in good operating condition / continuity
- Power Board supplies 12VDC to gas valve when required
- Replace Power Board.

ALL other fault codes will be displayed using flash patterns. The term "flash pattern" simply means the power ON indicator light is turned ON and OFF to create a numeric pattern. These flash patterns directly correspond to particular fault codes. That is to say, for example, fault code 3 will be indicated by flashing the power ON indicator light RED 3-times, followed by a 5-second pause, and then repeated as long as the fault condition is present. See Fig. 4 below.

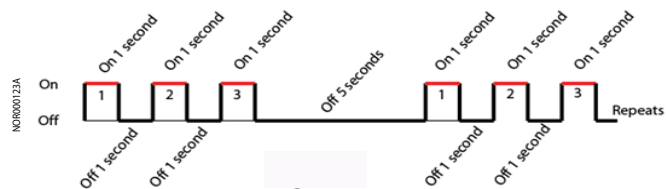
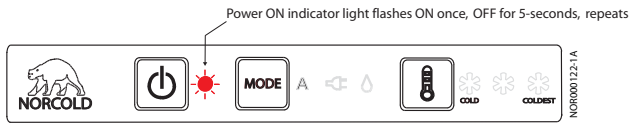

Fig. 4 - Flash Patterns

**Fault / Flash Pattern 1
AC Heater Error**



Flash Pattern "1" means the Power Board sensed the AC heater current to be too low. This fault can only be displayed while operating in the Manual AC Mode.

Verify:

- AC heater connections are in good repair and are properly connected to the Power Board; refer to refrigerator wiring diagram "Wiring Pictorial" on page 53 for proper connection.
- AC heater resistance measures between 46Ω and 51Ω; if not in range, replace AC heater.
- Replace power board.

**Fault / Flash Pattern 2
Service Error**

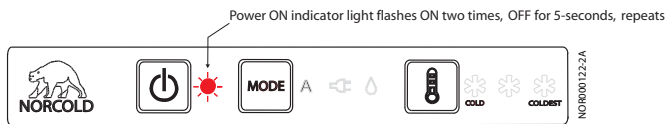

Flash Pattern "2" means the Power Board detected an internal fault. This fault can be reset by powering the refrigerator OFF and back ON. Should this fault continue to be displayed after being reset, the Power Board should be replaced. This fault can be displayed in ANY MODE.

**Fault / Flash Pattern 3
Open High Limit**

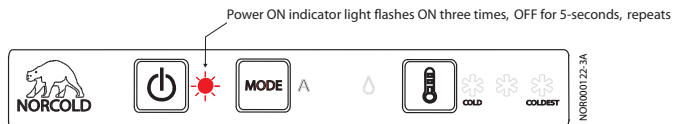

Flash Pattern "3" means the Power Board sensed the high limit thermal switch is open. This thermal switch is mounted to the metal insulation pack mounted above the burner. This fault can be displayed in ANY MODE.

Verify:

- Is thermal switch electrically open, i.e. has it tripped?
- If no, verify wiring is connected properly. Refer to refrigerator wiring diagram "Wiring Pictorial" on page 53 for proper connection.
- Replace power board.

**Fault / Flash Pattern 4
AC Relay Error**

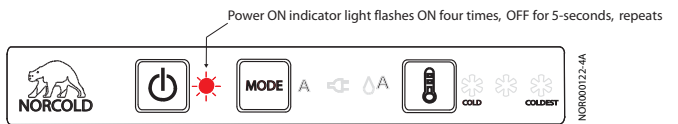

Flash Pattern "4" means the AC heater relay contacts of relay K2, on the Power Board, are stuck closed. This fault can be displayed in ANY MODE.

- Replace the Power Board

**Fault / Flash Pattern 5
Flame On Should Not Be On**

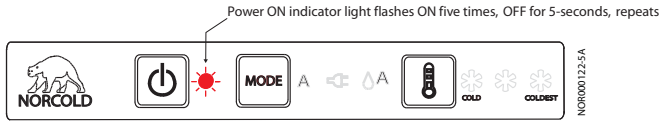

Flash Pattern "5" means the gas valve is "mechanically" stuck open and subsequently the Power Board has sensed a flame present when there should not be. This fault can be displayed in ANY MODE.

- Replace the gas valve

**Fault / Flash Pattern 8
LOW DC (1) Error**

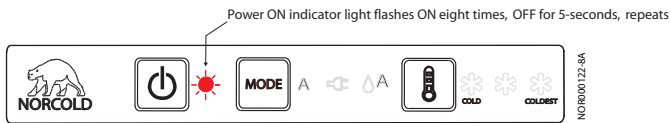

Flash Pattern "8" means the refrigerator attempted to ignite or re-ignite the burner when the DC input voltage was less than 10.0 VDC. The gas valve/igniter outputs are inhibited when there is a call for cooling and the DC voltage is less than 10.0 VDC. Should there be a call for cooling while the DC input voltage is greater than 10.0 VDC and the DC input voltage then falls below 10.0 VDC, the gas valve will remain energized and no fault will be displayed. This fault can only be displayed in the Auto and Manual LP modes.

Verify:

- That the battery charging equipment of the vehicle is operational
- That the AC/DC converter is operational (if applicable)
- If voltage is ≥ 10.0 VDC replace power board

**Fault / Flash Pattern 9
LOW DC (2) Error**

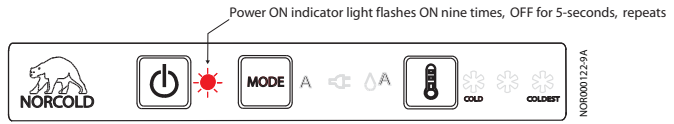

Flash Pattern "9" means the DC voltage to the refrigerator is less than 8.5 volts DC. All outputs are inhibited. This fault will automatically reset and outputs will be allowed to operate once the DC input voltage rises above 9.0 VDC (above 10.5 for 3-way models). This fault can be displayed in ANY MODE.

Verify:

- That the battery charging equipment of the vehicle is operational
- That the AC/DC converter is operational (if applicable)
- Contact Customer Service for further instructions.

Thermistor Fault

COLD indicator light(s) will flash OFF/ON at 1-second intervals (Only while control is "Awake")



A flashing COLD temperature indicator (snowflake) means the electronic controls have sensed the fin thermistor to be inoperable. This fault is only displayed while the optical display is awake. To wake the optical display, press and release either the Mode or Temp Set buttons. If a problem is sensed with the thermistor the COLD temperature indicator (snowflake) will flash ON and OFF. After 10-seconds the control will revert back to the sleep mode. This fault can be displayed in ANY MODE. Should the thermistor be sensed inoperable the electronic controls will ignore the thermistor and revert to a BOS mode (Backup Operating System). Refer to Backup Operating System (BOS) Mode section of this manual-on "Backup Operating System (BOS) Mode" on page 14.

Verify:

- The lamp-thermistor wire assembly is plugged in and that the connections are not dirty or broken (see Fig. 5A).
- Thermistor resistance (see Fig. 5B).

Door Fault

There is no displayed fault for an open door however; the interior light will automatically be turned off in the event the door has been sensed open for more than 2-minutes. The light switch, a magnetically activated reed switch attached to the optical display board, is activated by a magnet located beneath the refrigerator doors top trim piece. When the magnet is close to the reed switch (door closed) the light remains off; when the magnet is away from the reed switch (door open) the light is turned on. The open/closed status of the reed switch

is monitored by the optical display board and communicated back to the power board which in turn activates the interior light output accordingly. Because the switch operates via the proximity of the magnet, it is important that the door alignment is correct. To test for interior light operation, refer to Interior Light Test on "Interior Light Test Procedure" on page 25.

Blank Display

On-Off Theory of Operation:

Continuous 12-Volts:
See Fig. 6.- page 21

12VDC is supplied to the refrigerator at Power Board terminals 12VDC & GND [A]. This 12VDC travels through the Power Board to fuse F1 [B] and then out to P1-6 [C]. Via the green wire, the 12VDC exits the Power Board and enters the Display Board at P1-1 [D]. The 12VDC travels through the Display Board to one side of the normally open On-Off switch [E]. This 12VDC is referred to as the continuous 12-volts because it is always present at the one side of the On-Off switch when 12VDC power is applied to the refrigerator.

Switched 12-Volts:
See Fig. 7. - page 21

Pressing the On-Off switch [E] will allow 12VDC to pass through the On-Off switch and back to the Power Board via the blue wire [F] connected between the Display Board at P1-3 and the Power Board at P2-3. Once the 12VDC reaches the Power Board, a signal is sent out to the coil of relay K3 [G] via the U1 microprocessor. This signal allows the K3 relay to energize thus closing the normally open contacts [H].

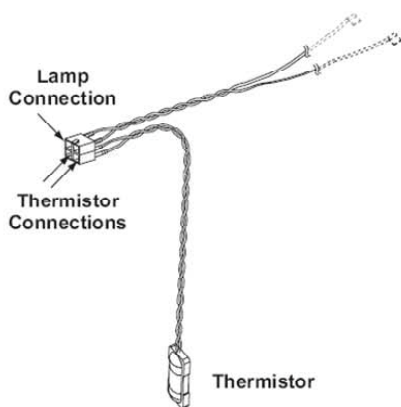
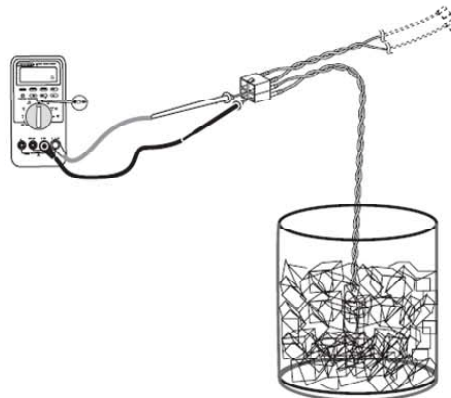

Fig. 5A - Thermistor



Thermistor packed in ice bath

Fig. 5B - Thermistor in Ice

Temperature* (°F)	Resistance* (kΩ)
85	8.1 to 9.0
80	9.1 to 10.0
75	10.1 to 11.0
70	11.1 to 12.0
60	12.1 to 13.0
50	15.5 to 16.5
40	22.5 to 23.5
35	24.5 to 25.5
33	28.5 to 29.5
32	30.0 to 32.0

*Approximate Values



Note: K3 is a latching relay. Once the relay coil is energized the contacts close and remain closed even when the 12VDC is removed, hence the term “latching relay”. With the K3 contacts now closed, 12VDC is passed back to the Display Board via the White-Red wire [J] between P1-9 of the Power Board and P1-2 of the Display Board. This 12VDC will remain at P1-2 until the latching relay is “un-latched”, which will not take place until the On-Off button is depressed again. This 12VDC is termed the switched 12-volts and is used to power ON the display.



Note: The On-Off switch [E] is a momentary push-button switch. The operation described above takes place during the “split second” the On-Off button is depressed to power the refrigerator on. If for some reason the display does not turn on, the On-Off button can be pushed and held down to aid in troubleshooting.

EXAMPLE: Verify you have 12VDC between P1-1 (GND) and P1-6 (continuous 12-volts) of the Power Board. Leave the meters black ground lead connected to P1-1 and move the red positive lead from P1-6 to P1-1 and move the red positive lead from P1-6 to P2-3 of the Power Board. Have someone press and hold the On-Off button. You should measure 12VDC as long as the On-Off button is held in. When the On-Off button is released you should see the 12VDC go away.

Blank Display – Continuous 12-Volts Operation Overview NX61 / NX81, NX64 / NX84, NXA64 / NXA84

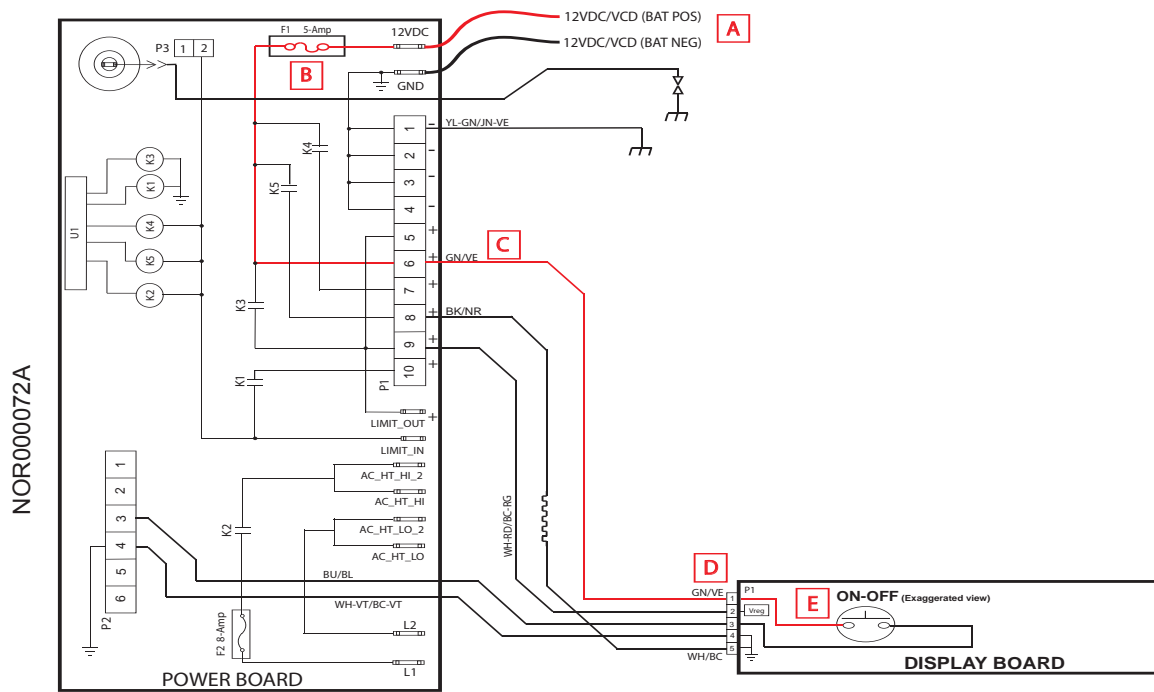

Fig. 6 - NX61 / NX81, NX64 / NX84, NXA64 / NXA84 Continuous 12-Volt

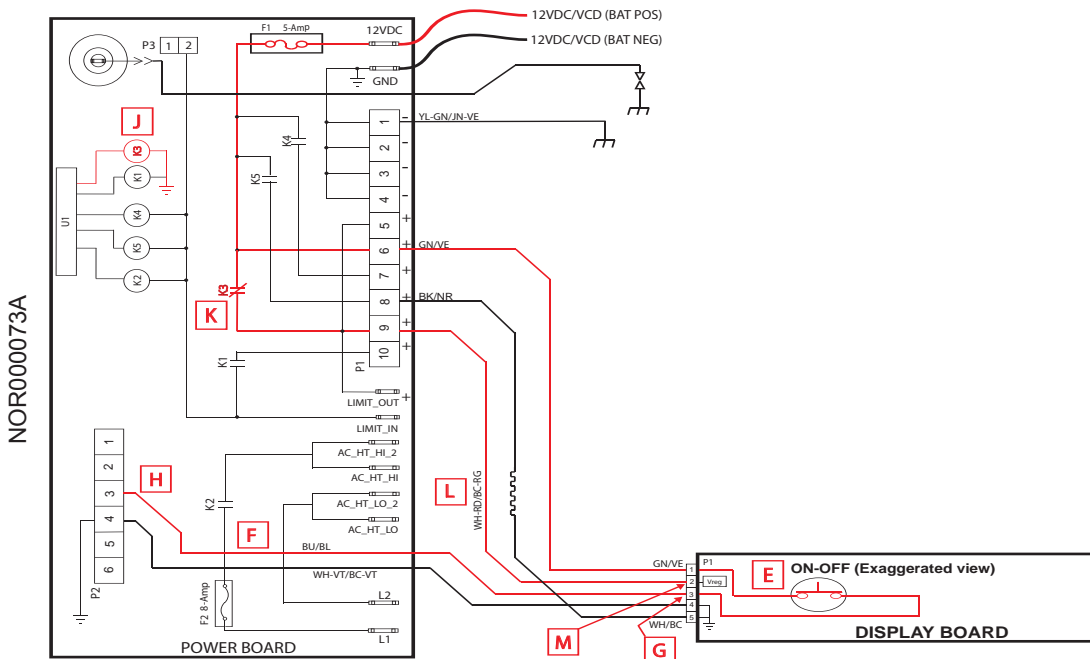
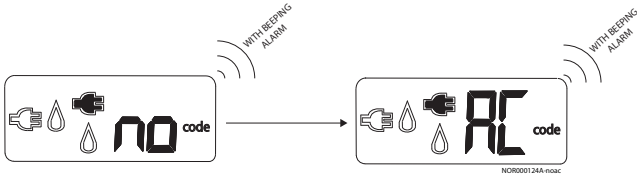

Fig. 7 - NX61 / NX81, NX64 / NX84, NXA64 / NXA84 Switched 12-Volts

NX64 / NX84, NXA64 / NXA84 Fault Codes

no AC



Meaning:

The Power Board sensed the refrigerators AC input voltage to be less than 85 volts. This fault, by itself, can only be displayed while operating in the Manual AC Mode. This fault can be displayed in conjunction with other faults while operating in the Auto Mode. For example; no AC followed by no FL (see Auto Mode discussion for further explanation).

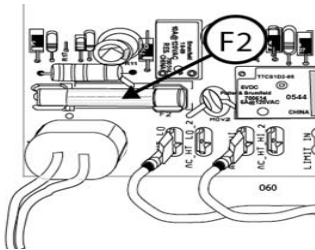

Verify:

- The refrigerator is plugged into a known working AC outlet supplying a minimum of 85VAC
- The AC power cord is in good operating condition
- The glass 8-amp fuse (F2) on the Power Board is intact
- Replace power board.

no FL

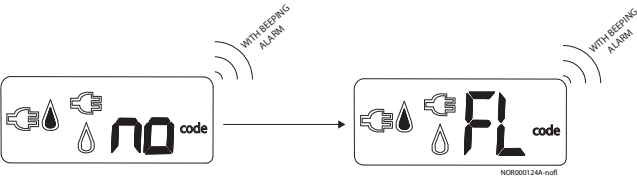

Meaning:

The Power Board was not able to detect a flame present at the burner. This fault, by itself, can only be displayed while operating in the Manual LP Gas Mode. This fault can be displayed in conjunction with other faults while operating in the Auto Mode. For example; no AC followed by no FL (see "Auto Mode" discussion for further explanation).

Verify:

- All LP gas shutoff valves (including manual shutoff on gas valve itself) are open
- LP Gas pressure at refrigerator is 11.5" W.C. (water column)
- LP gas supply line is free of air
- The burner is clean
- The electrode-to-burner air gap is between 1/8" and 3/16"
- The spark-sense igniter wire is installed correctly and in good operating condition

- Gas valve solenoid is in good operating condition (Coil resistance $\approx 74\Omega$ to 92Ω)
- Wires to the gas valve are connected and in good operating condition
- Power Board supplies 12VDC to gas valve when required
- Replace power board.

no AC, no FL

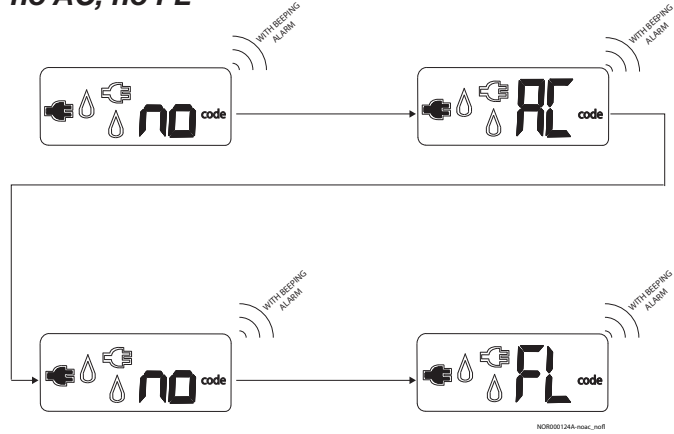

Meaning:

This fault is a combination of two separate faults. First, the Power Board sensed the AC input voltage to be less than 85VAC and automatically switched to the LP Gas Mode. Secondly, the Power Board was then unable to detect a flame while operating in the Auto LP Gas Mode. This fault can only be displayed while operating in the Auto Mode.

Verify:

- Follow the "Verify" instructions for the "no AC fault and "no FL" fault
- Replace power board.

oPLI

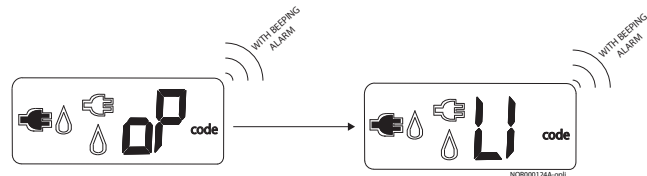

Meaning:

This fault means the Power Board sensed the high limit thermal switch is open. This thermal switch is mounted to the metal insulation pack mounted above the burner. This fault can be displayed in ANY MODE.

Verify:

- Is thermal switch electrically open, i.e. has it tripped? If yes, reset switch.
- If no, verify wiring is connected properly. Refer to refrigerator wiring diagram "Wiring Pictorial" on page 53 for proper connection.
- If yes, contact Customer Service for further instructions.

AC HE

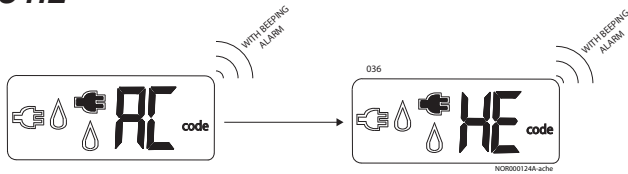

Meaning:

The Power Board sensed the AC heater current to be too low. This fault can only be displayed while operating in the Manual AC Mode.

Verify:

- AC heater connections are in good repair and are properly connected to the Power Board. (Refer to refrigerator wiring diagram on page 53 for proper connection.)
- AC heater resistance measures between 46Ω and 51Ω:
 - No - replace AC heater
 - Yes - Replace power board
- Contact Customer Service for further instructions.

AC rE

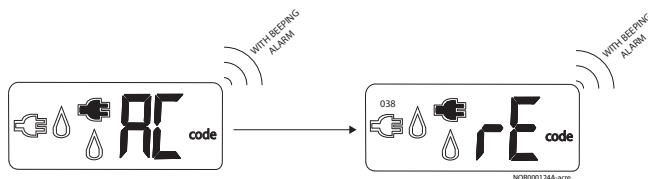

Meaning:

The AC heater relay contacts of relay K2, on the Power Board, are stuck closed. This fault can be displayed in ANY MODE.

- Replace the Power Board

FL --

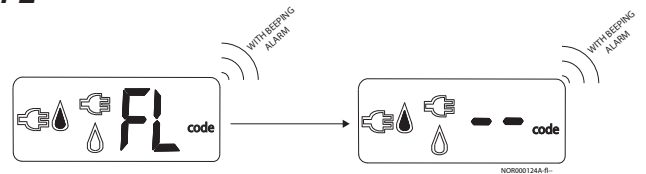

Meaning:

The gas valve is “mechanically” stuck open and subsequently the Power Board has sensed a flame present when there should not be. This fault can be displayed in ANY MODE.

- Replace the gas valve

Sr

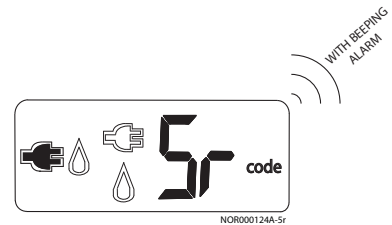

Meaning:

The Power Board detected an internal fault. This fault can be reset by powering the refrigerator OFF and back ON. Should this fault continue to be displayed after being reset, the Power Board should be replaced. This fault can be displayed in ANY MODE.

dc HE

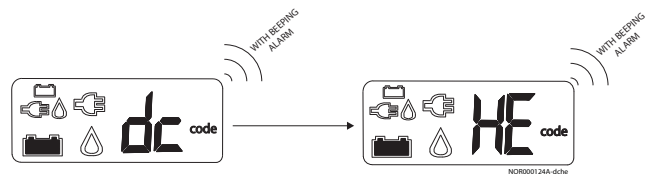

Meaning:

The DC Board has sensed the DC heater current to be too low. This fault can only be displayed in the Manual DC Mode.

Verify:

- 30 Amp fuse, F1 on the DC Board, is intact. If necessary, replace with 30 Amp (green color) automotive blade type fuse SAE J1284.
- Verify DC heater connections are in good repair and are properly connected. Refer to refrigerator wiring diagram for proper connection on page 53
- Verify DC heater resistance measures between 0.65Ω and 0.75Ω:
 - No - replace DC heater
 - Yes - Replace power board
- If voltage is in range, replace power board.

dc rE

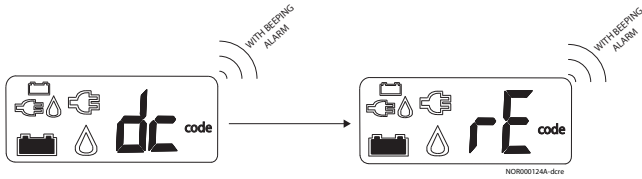

Meaning:

The DC heater relay contacts of relay K1, on the DC Board, are stuck closed. This fault can be displayed in ANY MODE.

- Replace the DC Board

Lo dc without alarm



Meaning:

The Power Board has determined the DC input voltage is less than 10.5 VDC. Anytime the DC input voltage falls below 10.5 VDC the low DC voltage fault is displayed and the divider heater is turned OFF. This fault will be cleared and the divider heater will be turned back ON when the DC input voltage is ≥ 11.5 VDC. This fault can be displayed in ANY MODE.

Verify:

- That the battery charging equipment of the vehicle is operational
- That the AC/DC converter is operational (if applicable)
- If voltage is within range, replace power board

Lo dc with alarm while in LP Gas Mode

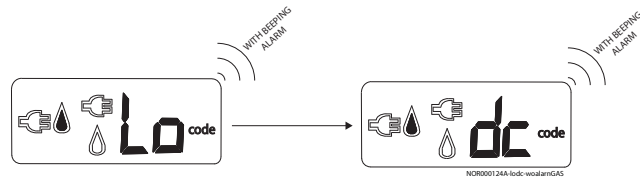

Meaning:

The refrigerator attempted to ignite or re-ignite the burner when the DC input voltage was less than 10.0 VDC. The gas valve/igniter outputs are inhibited when there is a call for cooling and the DC voltage is less than 10.0 VDC. Should there be a call for cooling while the DC input voltage is greater than 10.0 VDC and the DC input voltage then falls below 10.0 VDC, the gas valve will remain energized and no fault will be displayed. This fault can only be displayed in the Auto and Manual LP modes.

Verify:

- That the battery charging equipment of the vehicle is operational
- That the AC/DC converter is operational (if applicable)
- Contact Customer Service for further instructions.

Lo dc with Alarm

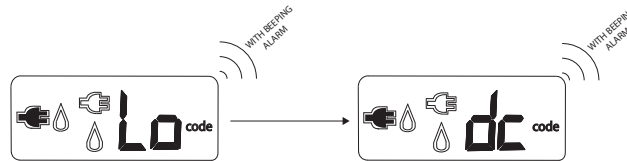

Meaning:

The DC voltage to the refrigerator is less than 8.5 volts DC. All outputs are inhibited. This fault will automatically reset and outputs will be allowed to operate once the DC input voltage rises above 9.0 VDC (above 10.5 for 3-way models). This fault can be displayed in ANY MODE.

Verify:

- That the battery charging equipment of the vehicle is operational
- That the AC/DC converter is operational (if applicable)
- If voltage is within range, replace power board

dr

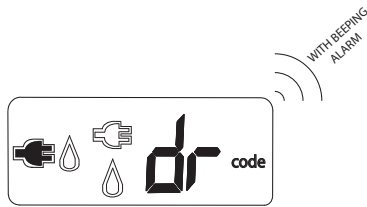

Meaning:

This fault indicates the optical display board has sensed the refrigerator door to have been open for more than 2-minutes. The interior light will automatically be turned off in the event the door has been sensed open for more than 2-minutes. The light switch, a magnetically activated reed switch attached to the optical display board, is activated by a magnet located beneath the refrigerator doors top trim piece.

When the magnet is close to the reed switch (door closed) the light remains off; when the magnet is away from the reed switch (door open) the light is turned on. The open/closed status of the reed switch is monitored by the optical display board and communicated back to the power board which in turn activates the interior light output accordingly. Because the switch operates via the proximity of the magnet, it is important that the door alignment is correct.

Interior Light Test Procedure:

- Place a magnetic tipped screwdriver or small magnet beneath the optical control
- Move the magnetic tipped screwdriver from side-to-side as shown below

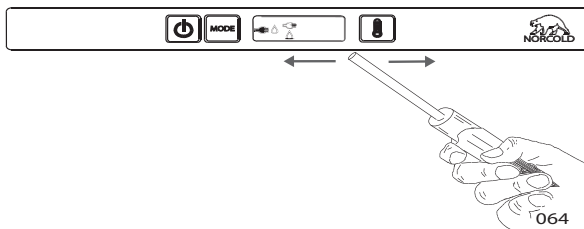

Interior Light Test

Verify:

- The interior light turns ON-OFF as the magnet is passed below the optical control
- Contact Customer Service for further instructions.

Blank Display:

Refer to "Blank Display" on page 19.

Flashing Temperature Setting Icon

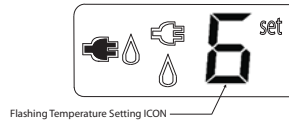

A Flashing Temperature Display means the electronic controls have sensed the fin thermistor to be inoperable. This fault is only displayed while the optical display is "awake." To "wake" the display press and release either the Mode or Temp Set buttons. If there is a problem sensed with the thermistor the temperature setting icon will flash ON and OFF. After 10-seconds the control will revert back to the "sleep" mode. This fault can be displayed in ANY MODE.

Should the thermistor be sensed inoperable the electronic controls will ignore the thermistor and revert to a BOS mode (Backup Operating System). The BOS mode is an electronically controlled duty cycle that allows the refrigerator to continue operating until such time the thermistor can be repaired or replaced.

This duty cycle will maintain refrigerator cooling by controlling the length of time the heat source outputs (AC heater, LP burner, or DC heater) are energized. The duty cycle, or length of time the cooling cycle is regulated, can be manually controlled via the TEMP SET button. When a colder temperature is desired, changing the temperature setting to the next "colder" setting will provide additional cooling by lengthening the cooling cycle. For example, if the temperature setting is set to 5, adjusting the temperature setting to the next colder setting of 6 will lengthen the cooling cycle. When a warmer temperature is desired, changing the temperature setting to a warmer setting shortens the cooling cycle. For example, if the temperature setting is set to 4, lowering the setting to 3 will shorten the cooling cycle.

Verify:

- The lamp-thermistor wire assembly is plugged in and that the connections are not dirty or broken. See Fig. 5A on page 19.
- Thermistor resistance. See Fig. 5B on page 19.

DIAGNOSTIC MODE - NX64 / NX84, NXA64 / NXA84

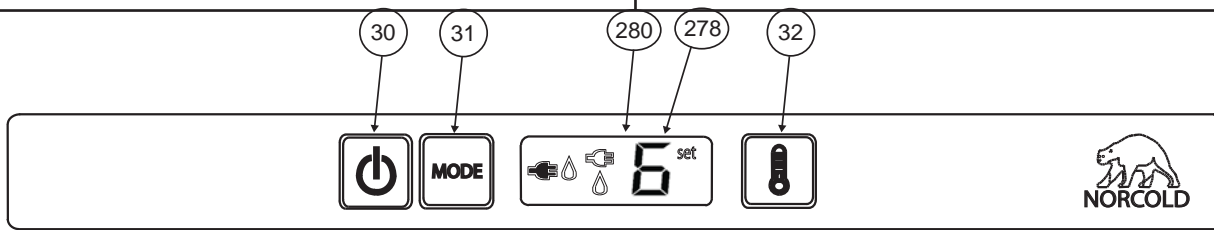

Fig. 8 - NX64 / NX84, NXA64 / NXA84 Display Board

Art02397

30 - Power On/Off Button

31 - Mode Button

32 - Temperature Set Button

280 - LCD (Liquid Crystal Display)

278 - Temperature Setting

Diagnostic Mode

The Diagnostic Mode uses ten diagnostic channels, commonly known as "screens", to display "live" inputs, outputs, and fault history. Each screen is identified by a number, which shows in the optical control assembly display. See Figure 8.

The NX64 / NX84, NXA64 / NXA84 optical control display uses a dual 7-segment LED module to display the screen number and diagnostic information. Information made up of four letters or digits displays in an alternating sequence. Fault history, "live" inputs, and outputs is presented using LED segments. The diagnostic LED segments, if present, display to the right of the screen number. Diagnostic LED segments identification numbers. See Fig. 9.

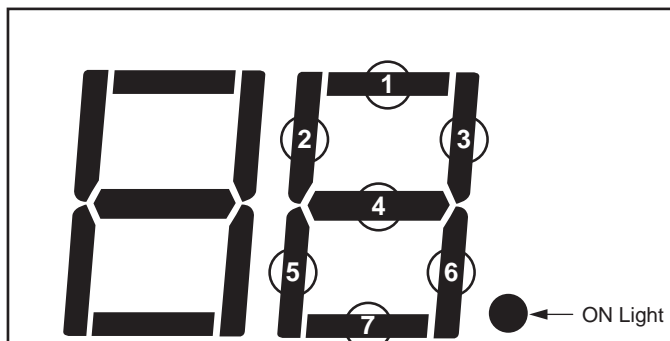

Fig. 9 - Diagnostic LEDs Segments Identification

Access Diagnostic Mode:

1. **Press and hold both** the and buttons **at the same time.**
2. **Release** the and as soon as screen displays.
3. A few seconds later, displays.

Change Screens

To change screens, **press and hold** the button until the next screen displays.

Exit Diagnostic Mode:

1. **Press and hold** and buttons **at the same time.**
2. **Release** the and buttons as soon as the display shows .

Turning the refrigerator OFF then back ON also exits the Diagnostic Mode.

Screens and Diagnostic Segments Information

Screen 1. Diagnostic Mode Active

Screen 1 verifies all icons are operational by turning them on. Note: Battery icon will not be displayed if 2-way model. See illustration.



Diagnostic Screen 1 (Initial View)

Diagnostic Screen 1 (Second View)

Press the  button to bring up screen 2.

Screen 2. LED Segments Reliability Check

Screen 2 verifies all icons are operational by turning them off. See illustration.



Diagnostic Screen 2 (Initial View)

Diagnostic Screen 2 (Second View)

Press the  button to bring up screen 3.

Screen 3. Thermistor Fin Temperature

Screen 3 displays the actual fin temperature being sensed by the thermistor. ***This is not the fresh food cabinet air temperature.*** The illustration below shows the fin temperature to be 20°F



Diagnostic Screen 3 (Initial View)

Diagnostic Screen 3 (Second View)

Press the  button to bring up screen 4.

Screen 4. Stored Fault History

Screen 4 displays stored fault history using lighted LED segments. Refer to illustration below for fault history definitions of the individual LED segments. ***If a fault occurred, its assigned fault history LED will be on.***



Diagnostic Screen 4 (Initial View)

Diagnostic Screen 4 (Second View)

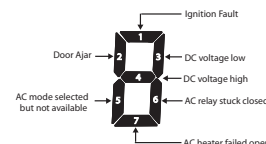

Press the  button to bring up screen 5.

Screen 5. Stored Fault History

Screen 5 also displays stored fault history using lighted LED segments. Refer to illustration below for fault history definitions of the individual LED segments. ***If a fault occurred, its assigned fault history LED will be on.***



Diagnostic Screen 5 (Initial View)



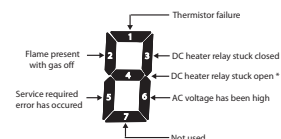

Diagnostic Screen 5 (Second View)



Press the  button to bring up screen 6.

Screen 6. Erasing Fault History

Screen 6 provides a way to erase fault history from memory. When first entering screen 6, Er will be displayed. To erase the fault history:

1. Press and hold the  button until  shows on the screen.
2. Once CL is displayed, release the  and wait 5 seconds.
3. Press and hold  until Er is displayed again. The fault history has been cleared.

Press the  button to bring up screen 7.

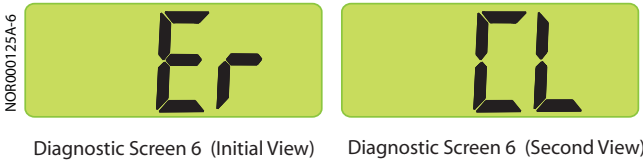

Screen 7. Power Board Inputs

Screen 7 displays "live" power board inputs using lighted LED segments. Refer to illustration below for "live" input definitions of the individual LED segments. **If a power board input is active or "live," its assigned input LED will be on.**

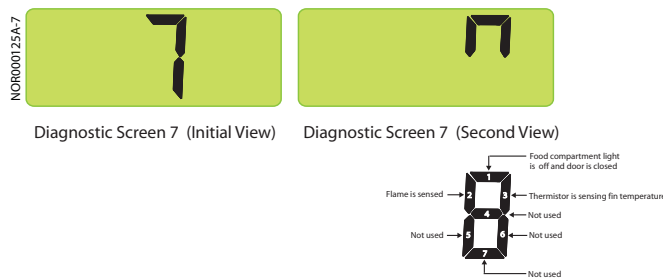

Press the  button to bring up screen 8.

Screen 8. Power Board Outputs

Screen 8 displays "live" power board outputs using lighted LED segments. The following illustration provides definitions of the "live" outputs indicated by the individual LED segments. **If a power board output is active or "live," its assigned output LED will be on.**

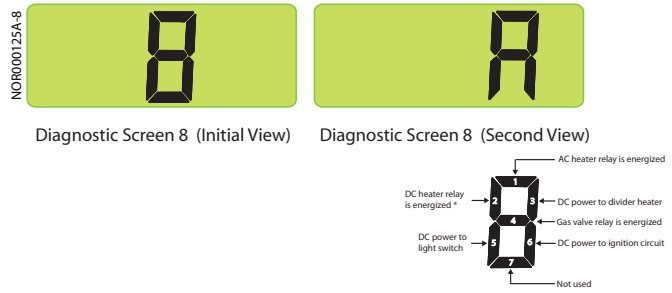

Press the  button to bring up screen 9.

Screen 9. Power Board DC Input Voltage Status

Screen 9 displays DC voltage status using lighted LED segments. Refer to illustration below for definitions of the individual LED segments. **If DC voltage at the power board is within normal range (10.5 to 15.4 Vdc), LED segment 4 will be on.**

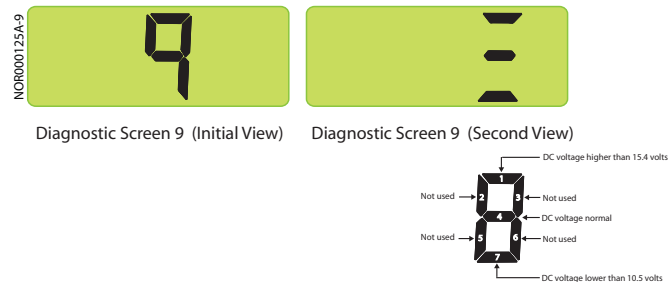

Press the  button to bring up screen 0.

Screen 0. Power Board AC Input Voltage Status

Screen 0 displays AC voltage status using lighted LED segments. Refer to illustration below for definitions of the individual LED segments.

If AC voltage at the power board is within normal range (108 to 132 Vac), LED segment 4 will be on.

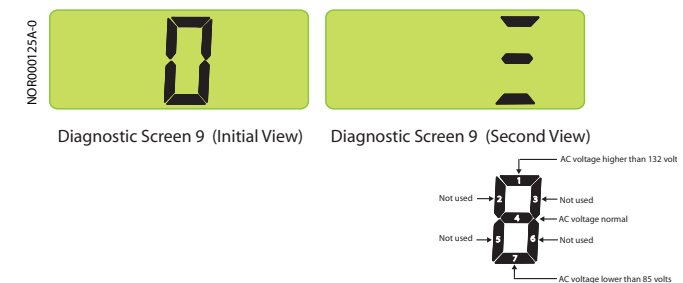

VENTILATION

Roof Exhaust Venting

NOTE

The guidelines for intake vents and roof exhaust vents presented in this section do not replace detail instructions. For latest information on approved vents, installation instructions, and special construction exceptions refer to:

- Installation Manual for NX61, NX81
- Installation Manual for NX64 / NX84, NXA64 / NXA84
- Ventilation Guidelines For Gas/Electric Refrigerators

The space between the air intake vent and the rear of the refrigerator must be kept clear at all times. Any obstruction in this area may cause serious ventilation problems. The air intake vent opening is also the access for servicing cooling unit components.

Roof Exhaust Vent

The heat absorbed by ventilation air and combustion gases flow out of the enclosure through the roof exhaust vent. See Figs. 10-11.

The roof exhaust vent is equipped with non removable metal mesh screen that prevent leaves, debris, birds or rodents from getting into the enclosure. The roof cap is fastened to the exhaust vent with four screws. The cap is always installed with the slope towards the front of the RV.

Air Intake Vent

The ventilation and combustion air flow into the enclosure through the air intake vent. See Figs. 9 and 11.

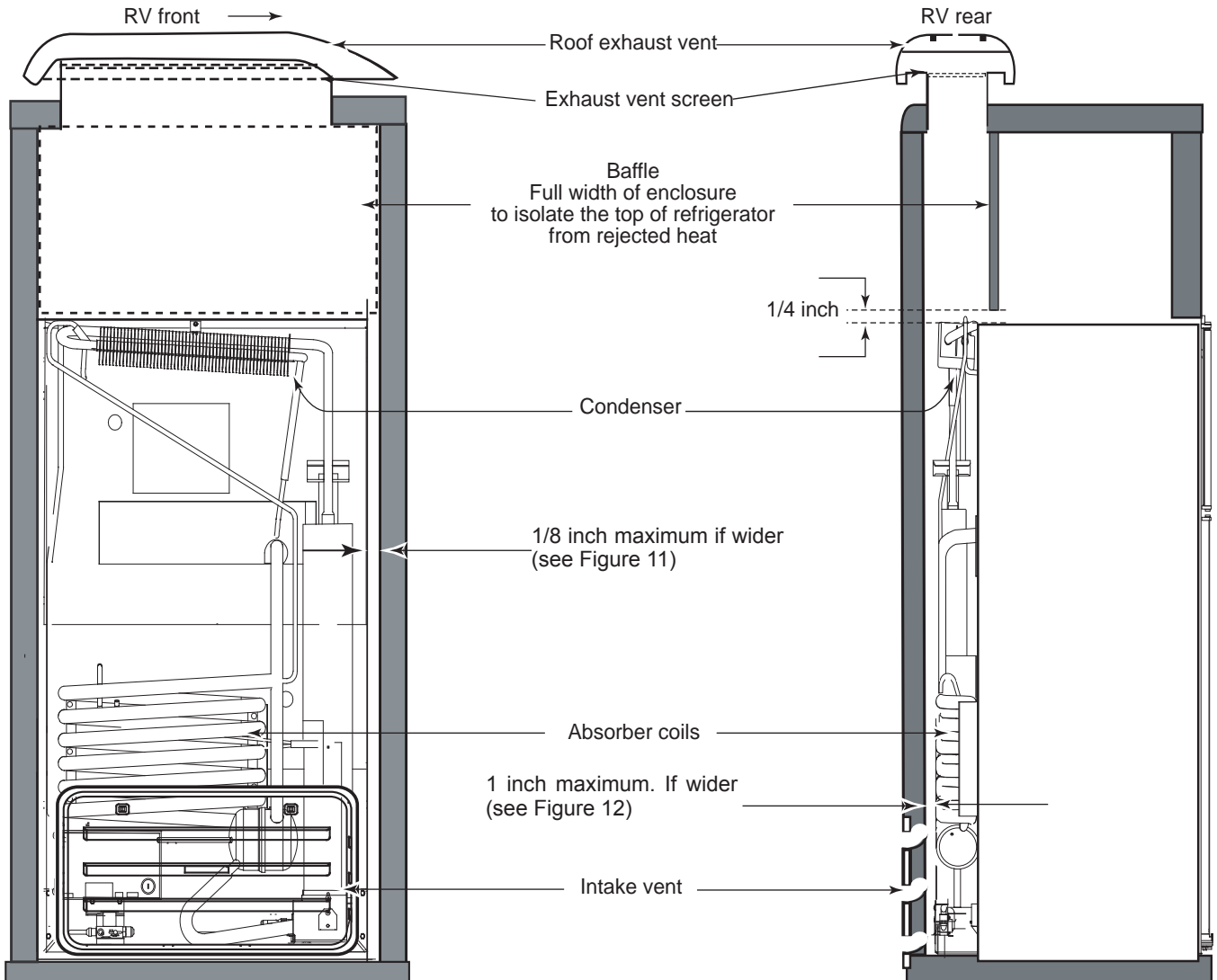

Fig. 10 - Roof Exhaust Venting Arrangement.

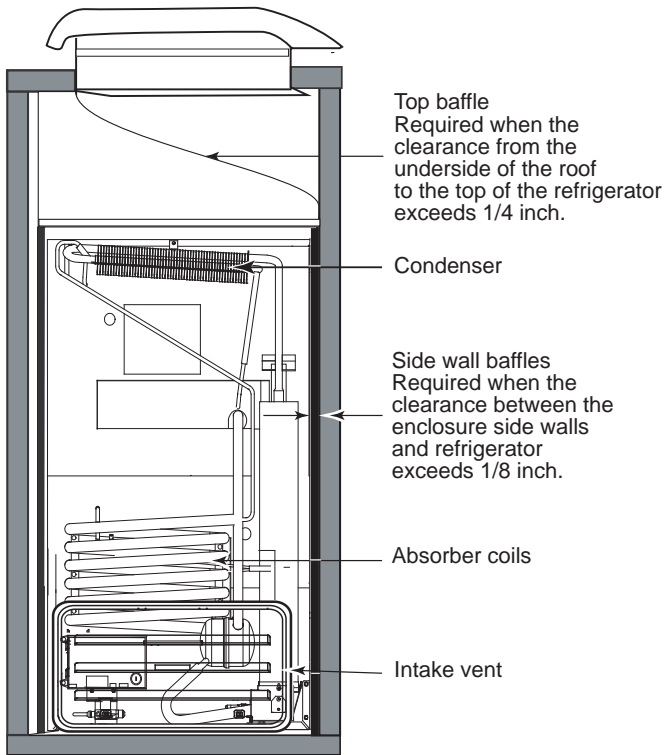

Fig. 11 - Rear View-Roof Exhaust Venting

Baffles

The minimum and maximum clearances for installing the refrigerator or correcting ventilation problems on roof vented units are listed in Table 1. Baffles are required whenever installations exceed maximum clearances listed in Table 3. Fig. 11 shows baffle locations.

Vertical Angled Baffles

Vertical angled baffles are required when the roof exhaust vent is installed inboard of the condenser. Fig.12 shows the angled vertical baffles required on inboard roof vent installations. The horizontal wall baffles are required whenever the distance between the cooling unit and the interior surface of the outside wall exceeds one inch.

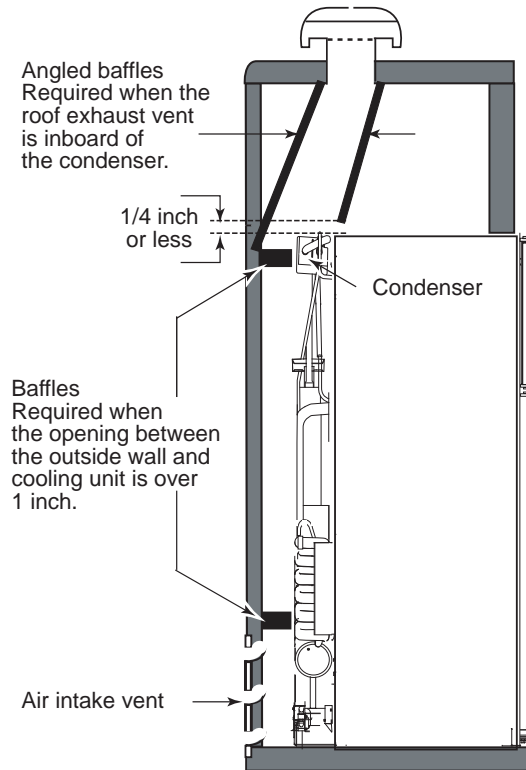

Fig. 12 - Baffles Required for an Inboard Roof Exhaust Vent Installation

	<u>Minimum</u>	<u>Maximum</u>
Bottom	0 inch	0 inch
Sides (each)	0 inch	1/8 inch
Top	0 inch	1/4 inch
Rear	0 inch	1 inch

Table 3: Clearances for Roof Vented Installations

Vertical Enclosures

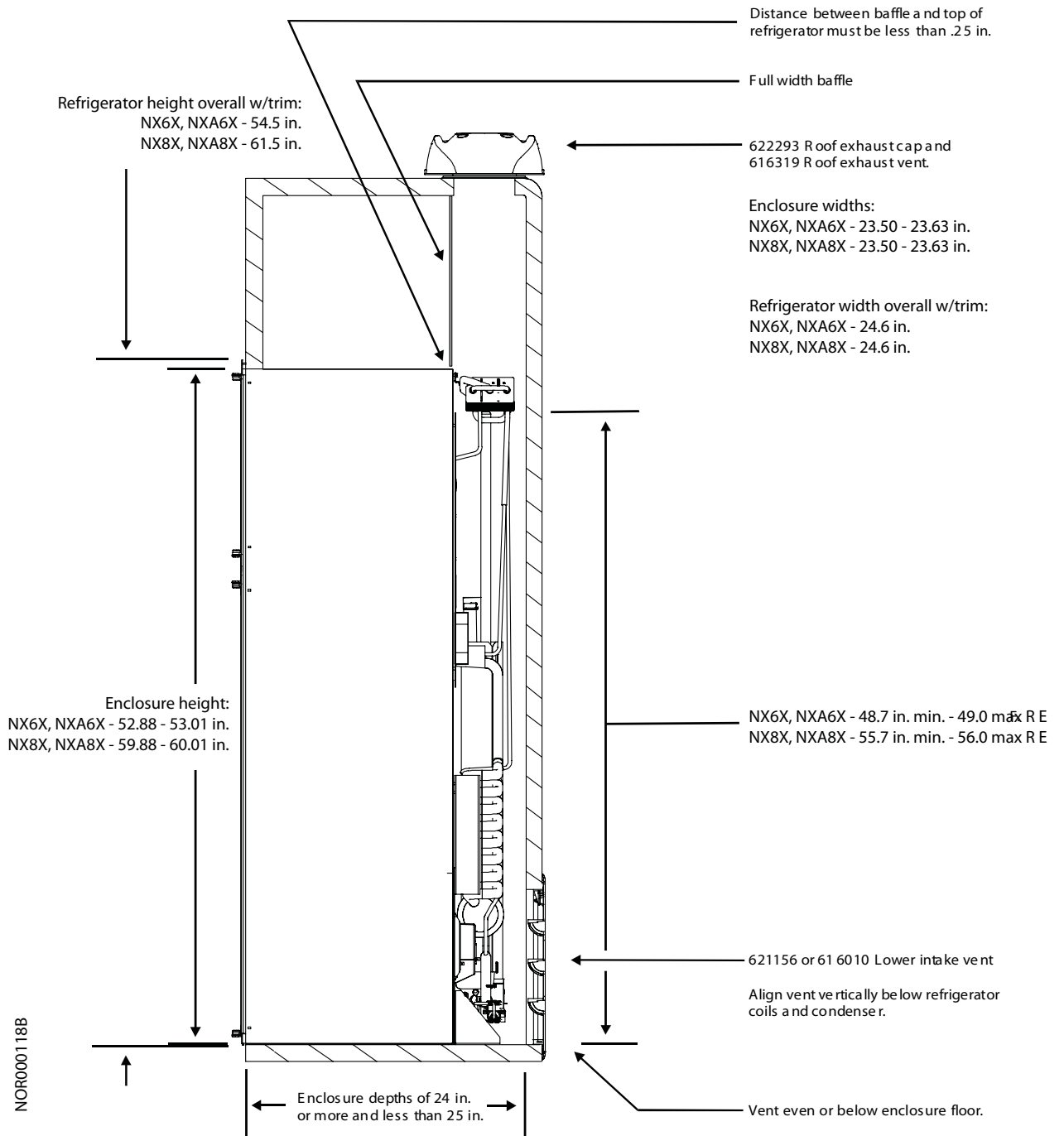

Fig. 13 - Vertical Enclosure Depth of 24 > 26 Inches

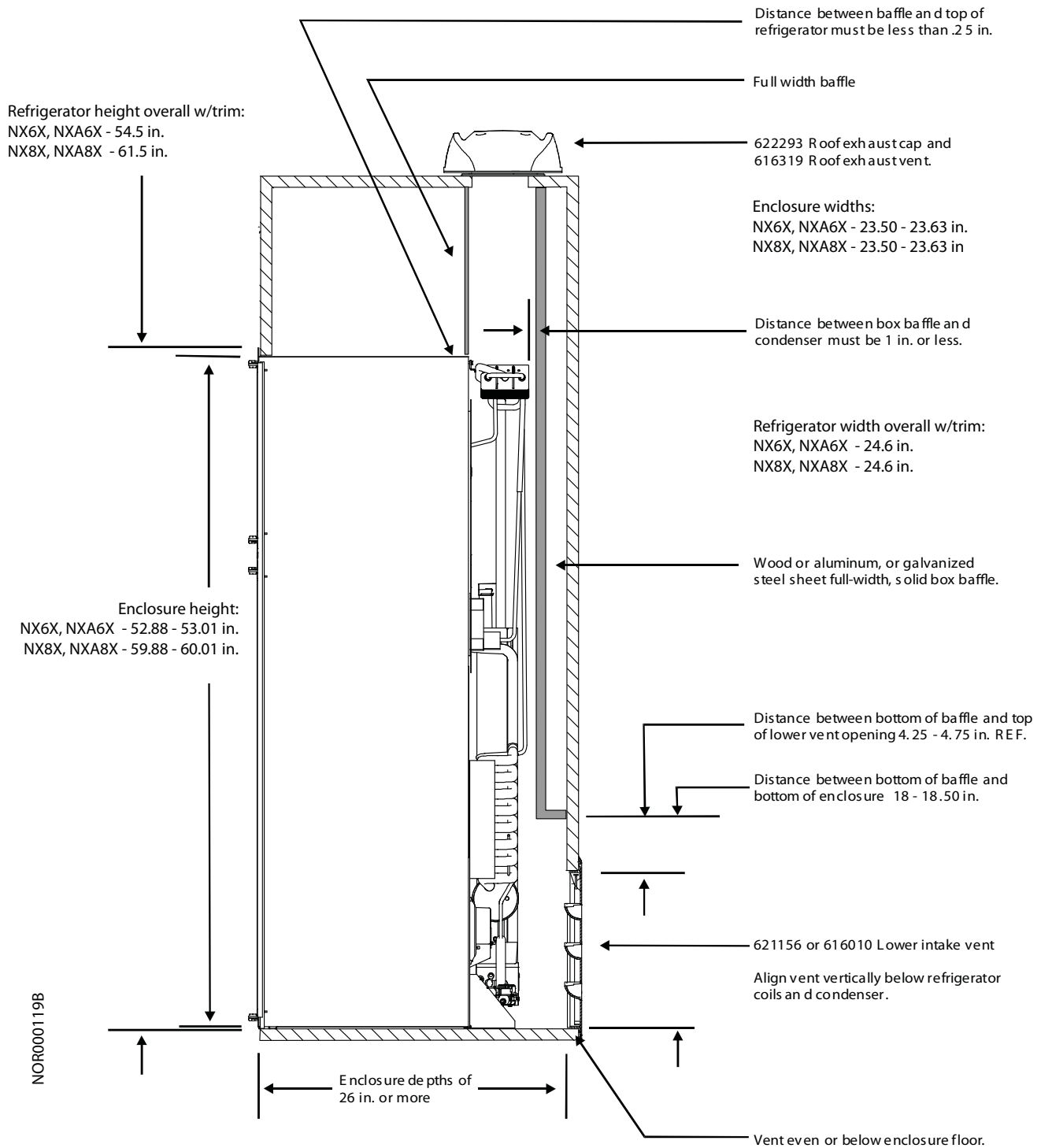

Fig. 14 - Vertical Enclosure Depth of 26 > Inches

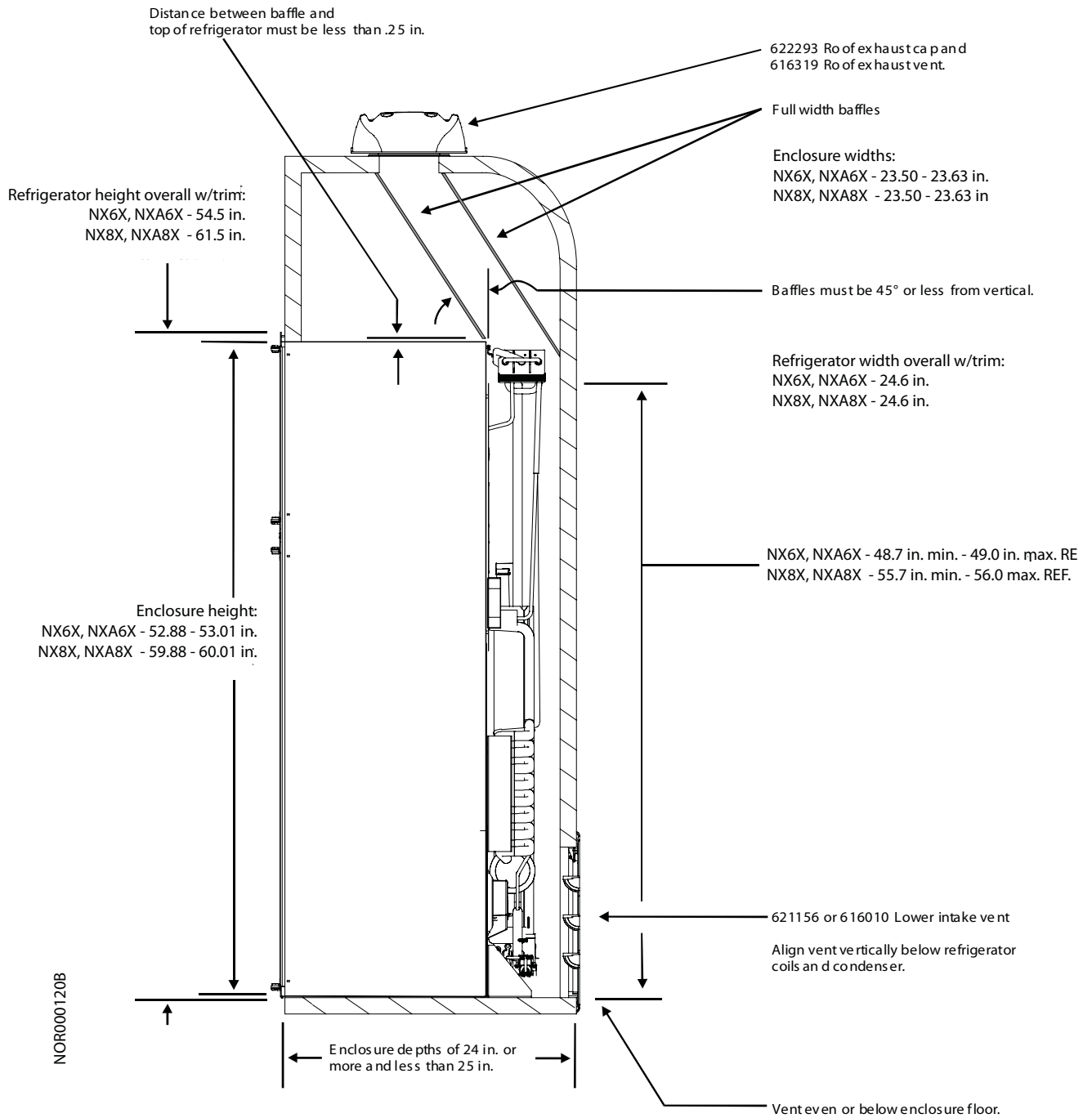

Fig. 15 - Offset Vertical Enclosure Depth of 24 > 25 Inches

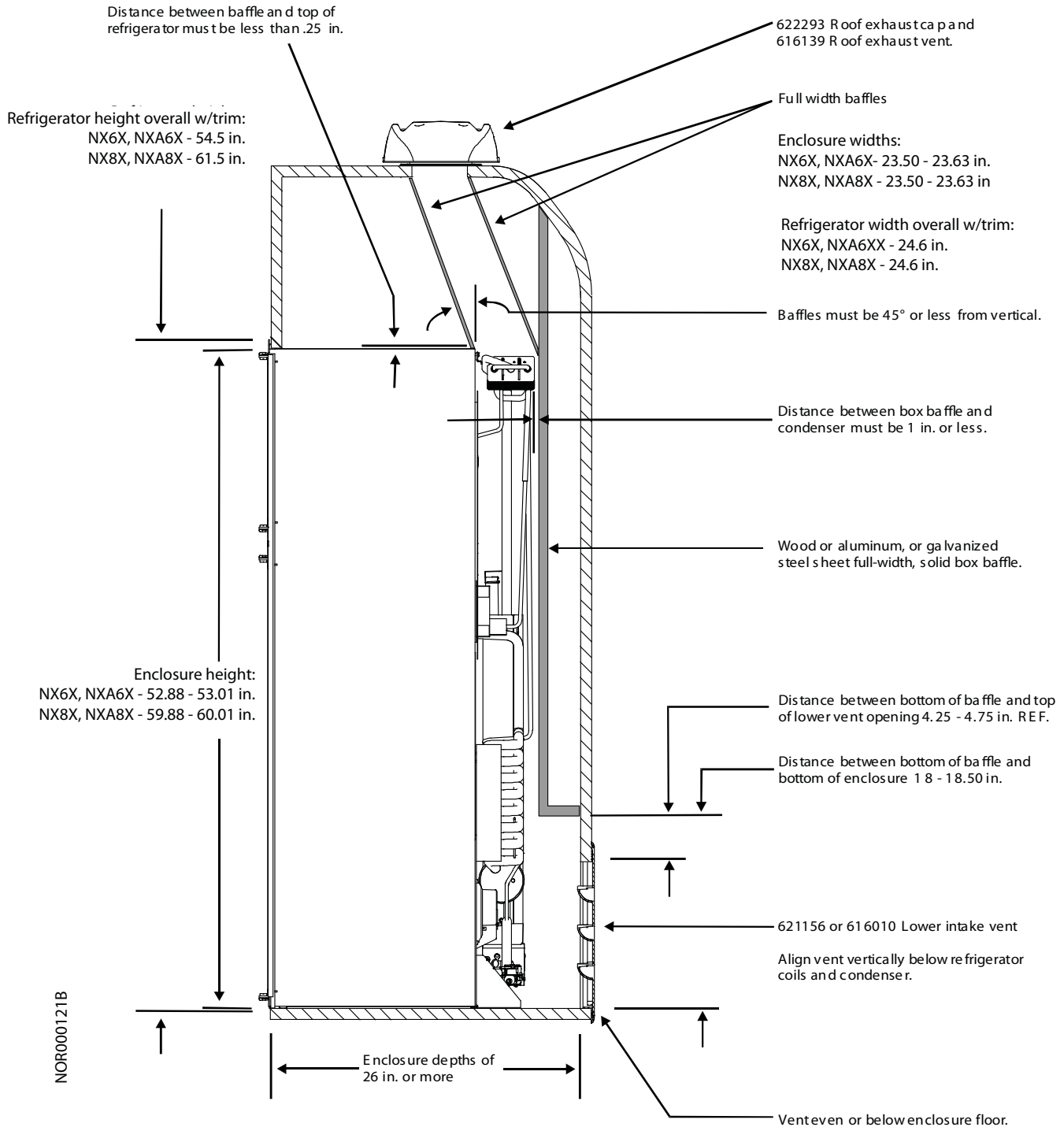

Fig. 16 - Offset Vertical Enclosure Depth of 26 > Inches

Double Sidewall Venting

NOTE

The guidelines for intake vents and roof exhaust vents presented in this section do not replace detail instructions. For latest information on approved vents, installation instructions, and special construction exceptions refer to:

- Installation Manual for NX61, NX81
- Installation Manual for NX64 / NX84, NXA64 / NXA84
- Ventilation Guidelines For Gas/Electric Refrigerators

An additional challenge with double sidewall venting is the depth of the enclosure. The deeper the enclosure, the greater the impact on the air flow through the rear of the refrigerator. Taking the three key design considerations and the variable depth requirement into account, NORCOLD developed and tested several baffle arrangements for the NX6X / NX8X, NXA6X / NXA8X models versus their ability to meet the ANSI standards.

As the result of this testing, NORCOLD was able to reduce the baffle configuration down to two baffles for the NX6X and NX8X models. It should be noted that baffle arrangements are different if the enclosure depth is greater than 24 inches or less than 26 inches. The baffle configurations are shown in Figs. 17 and 18.

With increased installation of refrigerators in RV slide outs, NORCOLD has conducted extensive testing to develop venting guidelines for double sidewall vent applications. This work was done to ensure NORCOLD refrigerators meet the ANSI Z21.19 standards for cooling performance when used in slide out applications.

The challenge with slide out installations is that the "chimney effect" that is present with roof vent installations is not as strong in slide outs. To improve the "chimney effect" side vent installations must have fans and baffles. These fans and baffles direct the air flow through the surfaces of heat rejecting components. NORCOLD has determined that the following three key design considerations optimize heat removal in slide out applications.

- Refrigerators installed in slide outs must have a fan or fans to assist air flow. Fan kits and refrigerators with factory installed fan(s) are available from NORCOLD.
- Fresh air must be directed to flow through the surface areas of the absorber coils, condenser fins, and the outer surface of the canister.
- Corners and structural pockets where heated air may stagnate must be reduced in size or completely eliminated.

Air Intake Vent

The ventilation and combustion air flow into the enclosure through the air intake vent. See Figs. 17 and 18.

Sidewall Exhaust Vent

The heat absorbed by ventilation air and combustion gases flow out of the enclosure through the sidewall exhaust vent. See Figs. 17 and 18 for details.

Double Side Wall Venting

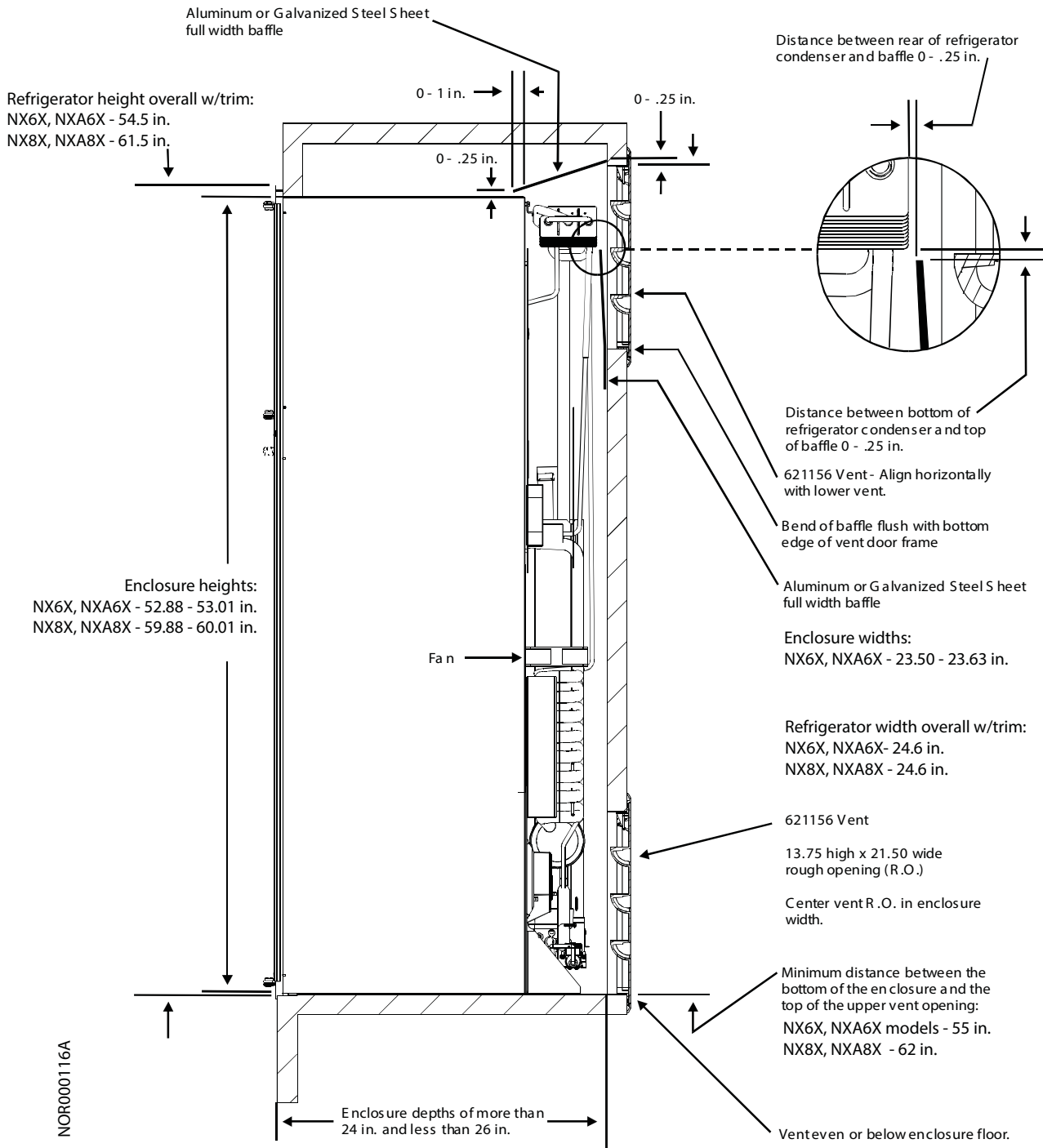

Fig. 17 - Double Side Wall Enclosure Depths of 24 > 26 Inches

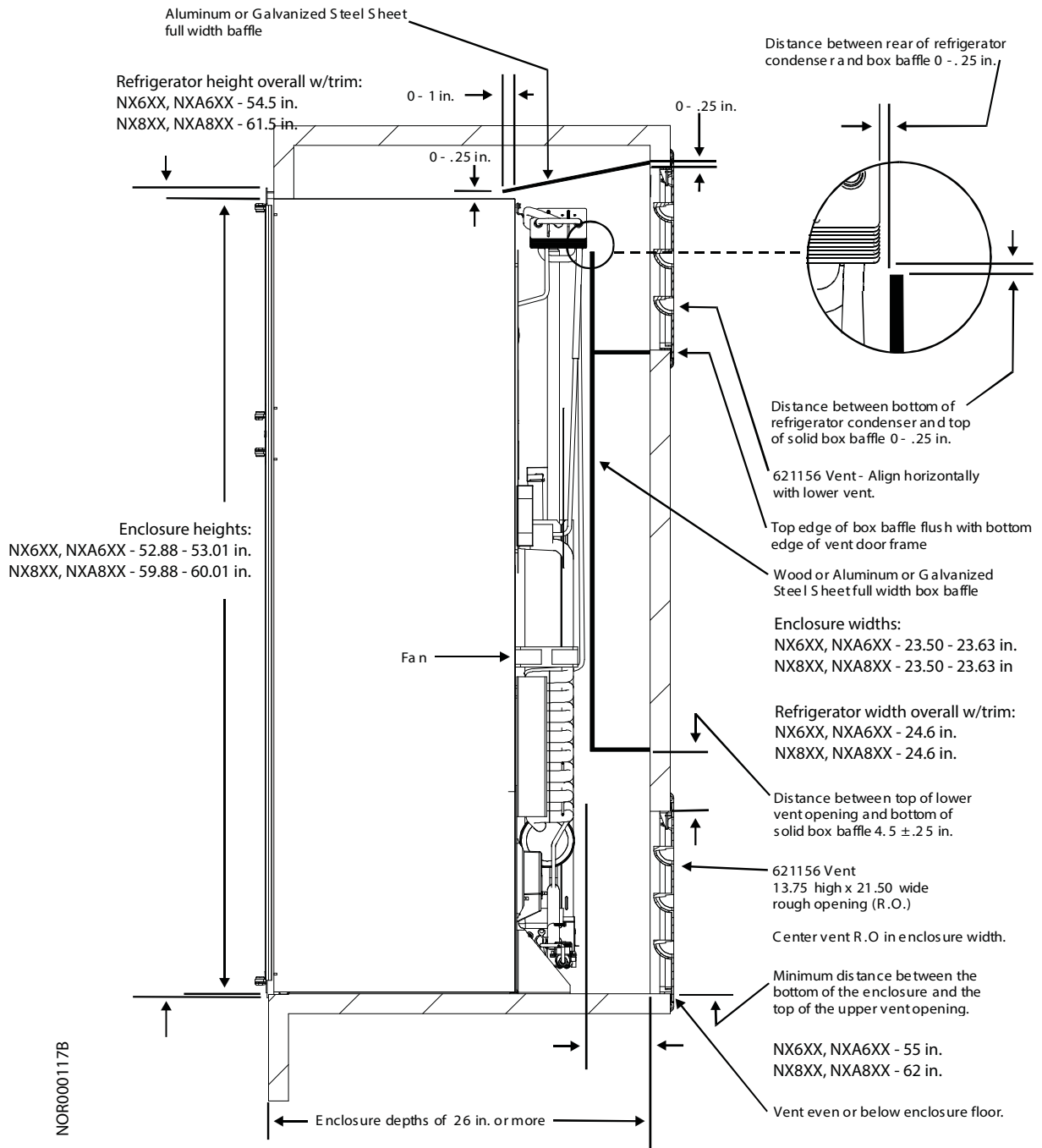

Fig. 18 - Double Side Wall Enclosure Depth of 26 > Inches

LP GAS SYSTEM

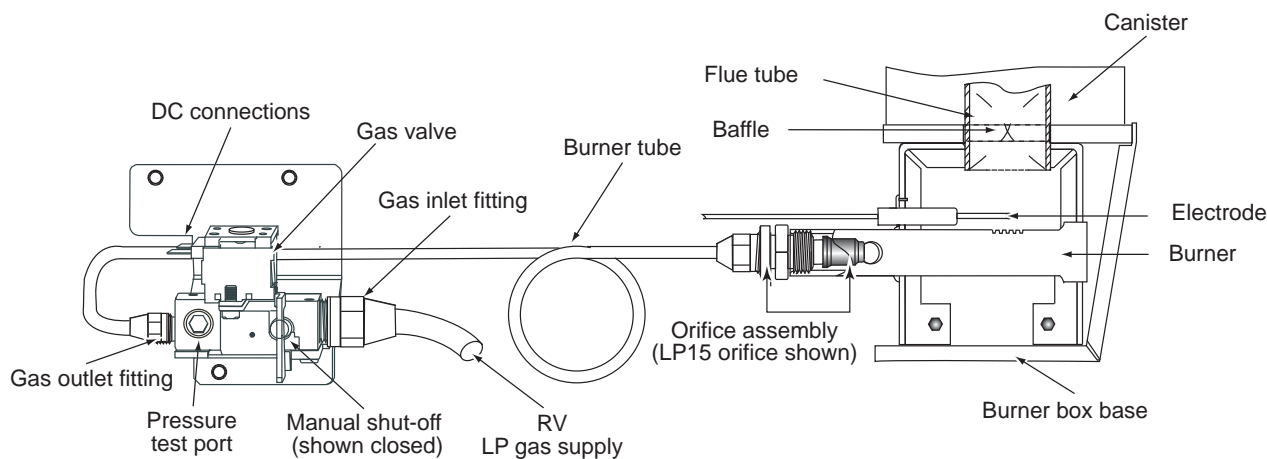

Fig. 19 - LP Gas System Components

Pressure Requirements

WARNING

When working on or near the LP gas system:

- Do not smoke or light fires! Extinguish all open flames!
- Do not use an open flame to leak test any of the LP gas system components. LP gas is highly flammable and explosive.
- Do not connect the refrigerator directly to the LP gas tank. Always use an approved pressure regulator between the LP gas tank and the refrigerator LP gas system.
- To prevent damage to connections, piping, and components, always use two wrenches to tighten or loosen connections. Damaged connections, piping, and components create the potential for gas leaks.

The refrigerator LP gas system, shown in Fig. 19, is for propane gas use only. The system working pressure is 10.5 to 11.5 in. water column. Propane gas pressures below 10.5 in. w.c. or above 11.5 in. w.c. will affect heat output which in turn will affect cooling efficiency.

Testing for LP Gas Leaks

WARNING

Do not wet or spray liquids on or near electrical connections or electronic components. Many liquids, including leak detection solutions, are electrically conductive and can create an electric shock hazard, short electrical components, and/or damage electronic circuits.

CAUTION

Do not use leak test solutions that contain ammonia or chlorine. Ammonia and chlorine attack copper and brass components.

Leak testing can be accomplished using an electronic leak detector or a commercial grade leak test solution. The use of home made soap and water leak test solution should be avoided if possible. When applying leak test solutions, apply the solution over the entire joint using a small brush or spray applicator.

Due to low system operating pressure, it may take a few minutes for bubbles to appear if the connection is leaking. Hidden joints should be examined thoroughly using an inspection mirror.

Components

When working on the refrigerator LP gas system:

- Do not alter or modify the burner tube anti-vibration loop.
- Do not cross thread fittings. Exercise extreme care when connecting and disconnecting propane gas components.
- Leak test all of the refrigerator propane gas system fittings after servicing, replacing, or repairing any LP gas system component.

Solenoid Gas Valves

The manual shut-off valve and the pressure tap are integrated into the solenoid gas valve. To manually shut-off gas to the burner, rotate the knurled shut-off knob one-quarter turn (90 degrees) clockwise until the screw slot on the face of the knob is vertical or perpendicular to the flow of gas.

Solenoid Gas Valve Connections

The solenoid gas valve inlet fitting is 3/8 inch, male threads; the outlet fitting is 1/4 inch, male threads.

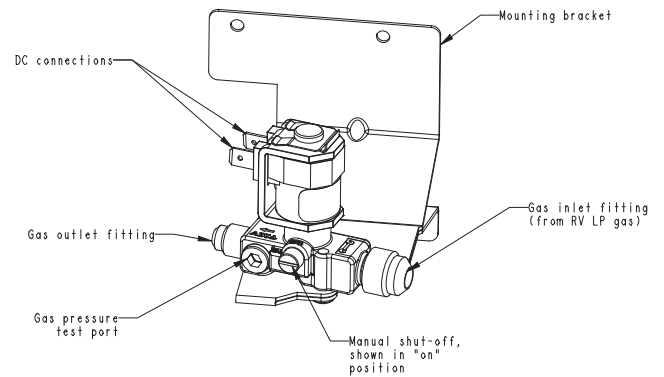

Fig. 20 - Solenoid Gas Valve.

Orifice

The orifice controls the flow of propane gas to the burner. When replacing the orifice always use the size orifice specified. Using the wrong size or a damaged orifice will alter the amount of propane flowing to the burner.

 **WARNING**

Do not separate cap style LP15 orifice from its adapter. Separating the assemblies breaks the seal and causes an LP gas leak.

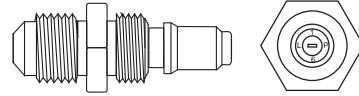

Cap type LP15 orifice assembly

Fig. 21 - LP15 Orifice Assemblies

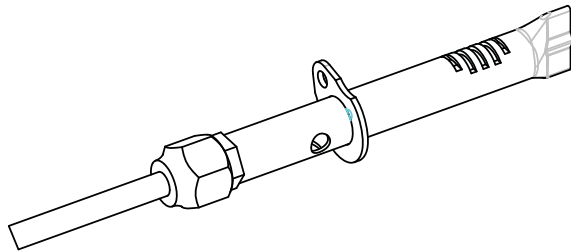

Fig. 22 - Burner

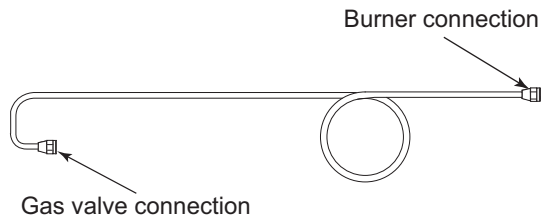

Fig. 23 - Burner Tube

Burner

The burner, see Fig. 22, provides primary air access and acts as the fuel mixing chamber to support ignition and the combustion of propane gas. Primary combustion air flows into the burner through three circular openings. Any obstruction blocking any of the three openings will have an effect on the fuel/air mixture. Insufficient combustion air will cause carbon deposits to clog the burner slots. Carbon clogged burner slots along with heavy dirt deposits in the burner are the main cause of no cooling or poor cooling performance when the refrigerator is operating in LP gas mode.

Burner Tube

The burner tube is 1/4 inch OD aluminum tubing with an anti-vibration loop and a double flare at each end. See Fig. 23.

Flue

The flue on all NX6X / NX8X, NXA6X / NXA8X terminates a few inches above the canister. See Fig. 24. The flue comes equipped with a removable baffle ("spiral baffle") and a metal heat deflector.

The flue and its components should be checked annually. In roof exhaust venting applications, the refrigerator must be removed from the enclosure to check or service the flue or any of its components.

In most sidewall exhaust venting applications, removal of the side wall exhaust vent provides clear access to service the flue or any of its components.

A one inch diameter, loop-handle, twisted wire brush with a 27 inch wire handle is recommended for sweeping clean the flue.

Heat Deflector

The heat deflector, deflects hot exhaust gases to the sides. See Fig. 24. It also keeps dirt and debris from getting into the flue. Cooling performance may be affected if the heat deflector is not installed or is not installed correctly.

Spiral Baffle

The spiral baffle, traps and transfers heat to the cooling unit generator. See Fig. 24.

A retaining wire suspends the spiral baffle in the flue just above the flame. See Fig. 25. The spiral baffle should be checked annually. To remove the spiral baffle from the flue:

1. Remove the heat deflector.
2. Unclip the baffle retaining wire from the rim of the flue.
3. Pull the baffle out of the flue tube.

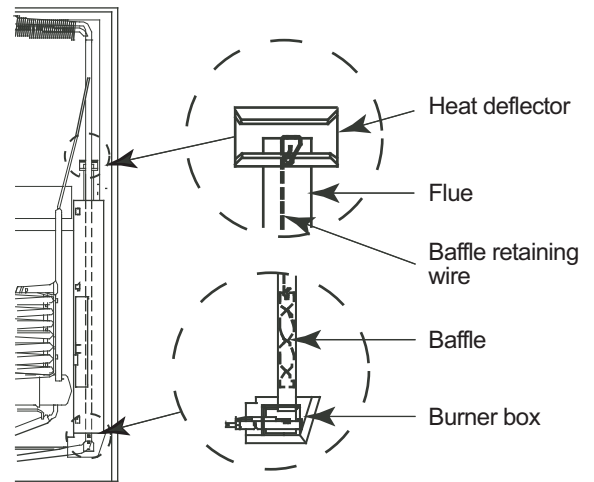

Fig. 24 - Flue and Components

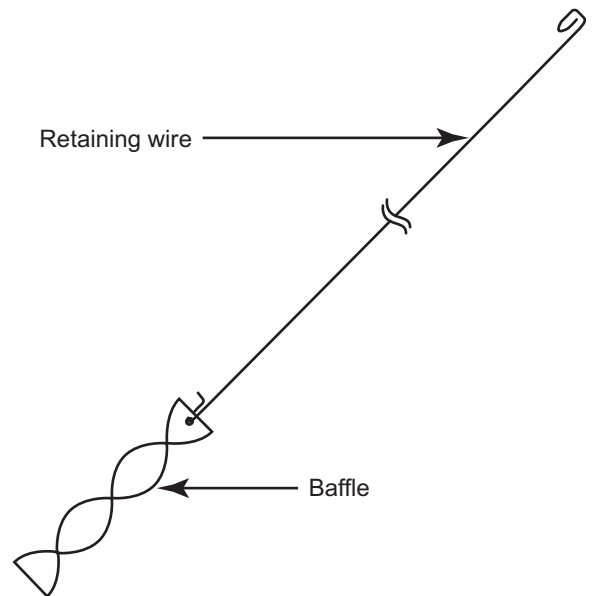



Fig. 25 - Flue Baffle

 **CAUTION**

Do not cut or modify the spiral baffle retaining wire! The wire positions the baffle for optimal heat transfer.

Flame Appearance

The flame should be light blue with sharp blue root cones and a steady burning flame plume. See Fig. 26.

A flame that is mostly orange or yellow, is erratic, and unstable, indicates a "dirty" burner. Burner cleaning procedures appear on page 42

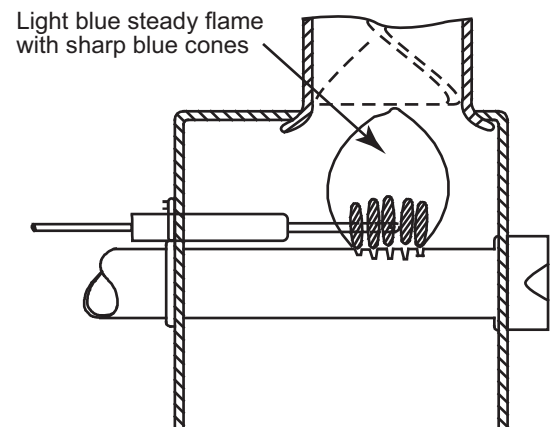

Fig. 26 - Flame Appearance

Burner Cleaning Procedure

 **WARNING**

Burn hazard! Allow the burner box and burner components to cool before attempting to service the burner assembly or components.

1. Turn OFF power to the refrigerator.
2. Close the LP gas tank valve.

Step 3 through Step 5, refer to Fig. 27 on page 43.

3. Close the combination gas control valve manual shut-off.
4. Remove the drip cup.
5. Remove the burner box cover.

 **WARNING**

To prevent damage to connections, piping, and components, always use two wrenches to loosen the burner tube. A damaged burner tube creates a potential for gas leaks.

Step 6 through Step 8, refer to Fig. 28 on page 43.

6. Disconnect the burner tube from the orifice assembly.
7. Remove the orifice assembly from the burner.
8. Remove the burner retaining screw.
9. Remove the burner from the burner box frame.
10. Clean the burner.
11. Visually inspect the orifice. If dirty, wash the assembly with alcohol then allow to air dry. Replace the orifice assembly if the cleaning fails to remove dirt or if the condition of the orifice assembly is questionable.
12. Clean any accumulation of dirt or debris from the burner box base.

NOTE

The burner slots may be cleaned with a small flat file. The inner bore of the burner body may be cleaned with a 3/16 in., double-spiral wire brush. Do not damage the threads when cleaning the inner bore of the burner.

NOTE

Do not insert any type of cleaning tool or wire into the orifice. Do not drill or ream the orifice opening to clean it. Insertion of any type of cleaning tools, reaming, or drills through the opening will alter the volume of LP gas flow to the burner and create a fire hazard potential.

13. Reinstall the burner. Do not over tighten the burner's retaining screw.
14. Install the orifice assembly. First thread the orifice assembly into the burner finger tight, then finish tightening using two wrenches.
15. Connect the burner tube. First thread the fitting finger tight, then finish tightening using two wrenches.
16. Install the burner box cover. Do not overtighten the cover retaining screw.
17. Open the LP gas tank valve.
18. Open the solenoid gas valve manual shut-off.

 **WARNING**

To avoid gas leaks and prevent damage to connections, piping, and components, always use two wrenches to tighten the burner tube. A damaged burner tube creates a potential for gas leaks.

19. Turn ON the refrigerator and select LP manual mode operation.
20. Leak test LP gas connections during the 30 second trial-for-ignition.

 **WARNING**

Do not attempt to repair LP gas leaks with the refrigerator in operation. Before attempting to repair a gas leak:

- Turn OFF the refrigerator.
- Close the LP gas valve and the solenoid gas valve manual shut-off.

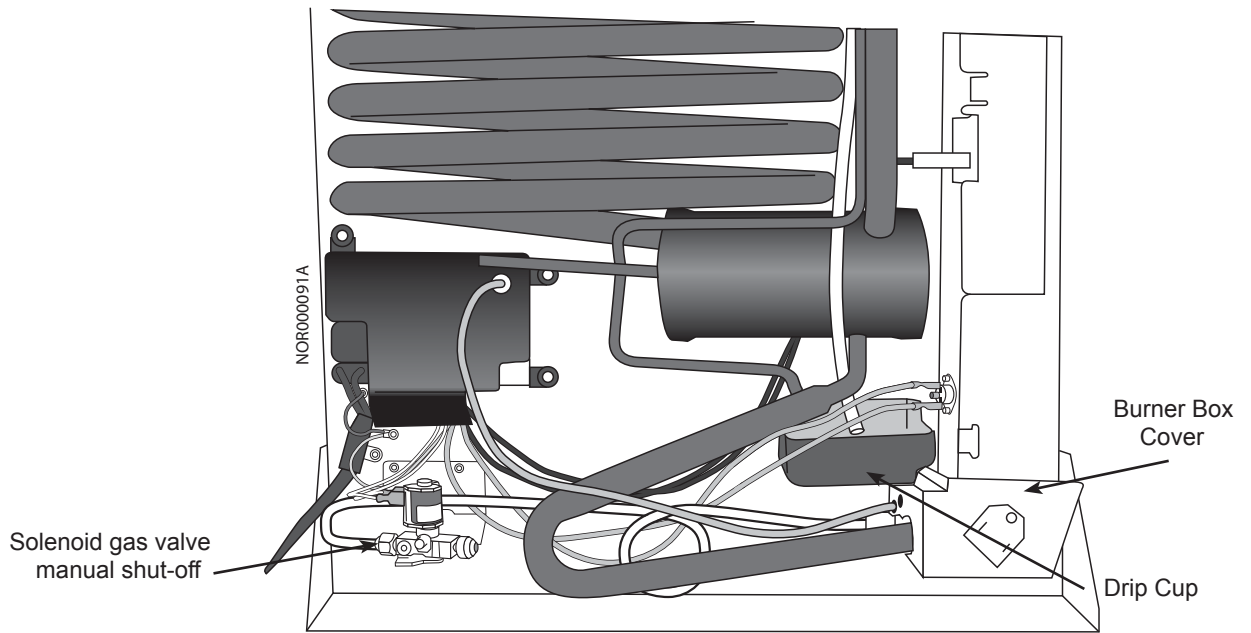

Fig. 27 - Drip Cup and Burner Box Cover

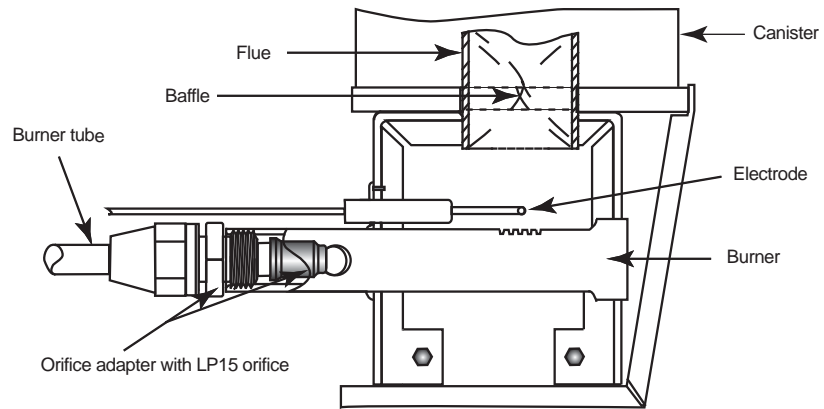

Fig. 28 - Burner and Components

Gas Lockout

For safety reasons, the refrigerator's electronic controls are designed so the ignition trial (maximum amount of time the gas valve and igniter can be left on) is limited to 30-seconds when operating in the (AUTO or MANUAL) LP GAS mode. Certain conditions can cause air in the gas supply line which may result in a gas lockout condition.

Conditions That Cause Air in Gas Supply Lines

- When starting the refrigerator for the first time
- After storage
- After replacing the propane gas tank

Results of Air in Gas Supply Lines:

- Gas valve and igniter outputs will be turned off
- LP Gas mode will be "locked out"
- Fault code displayed on the optical display
- NX61 / NX81: Power ON indicator is SOLID RED
- NX64 / NX84, NXA64 / NXA84:
 - Manual LP Mode - no FL w/audible alarm
 - Auto Mode - no AC, no FL w/audible alarm

NX61 / NX81

Solid Red Indicator Light

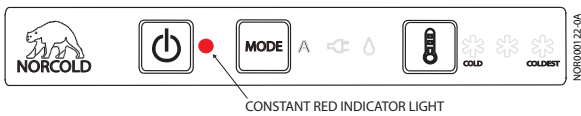

Refer to NX61 / NX81 section for additional details.

NX64 / NX84, NXA64 / NXA84

Manual LP Mode

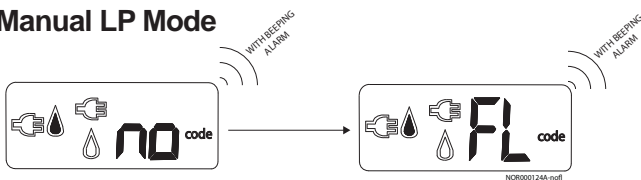

Auto Mode

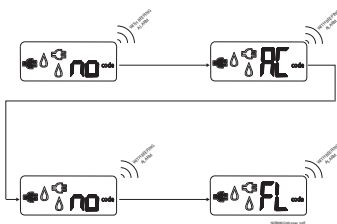

Reset a Gas Lockout Condition - All Models

To reset a gas lockout condition, power the refrigerator Off and back ON. The amount of air in the LP gas supply lines determines if the procedure needs to be repeated several times.

NX61 / NX81, NX64 / NX84, NXA64 / NXA84 Gas Safety Valve Test:

1. Open lower intake vent at refrigerator rear.
2. Remove both white wires from gas valve solenoid
3. Insert volt ohm meter leads into white wires and set meter to read DC volts.
4. Power ON refrigerator; select Manual LP Mode.
5. Verify meter reads approximately 12 volts DC and igniter sparks at burner
6. After approximately 30 seconds, 12 volt output measured at white wires is 0 volts and sparking at burner will stop. This means the gas valve safety circuit is operating correctly. The appropriate error will display on the optical display
7. Reconnect white wires to the gas valve solenoid (it doesn't matter what wire is attached to what terminal)
8. Close lower intake vent
9. Power OFF the refrigerator

ELECTRICAL REQUIREMENTS AND COMPONENTS

DC Voltage Requirements and Polarity

Operating controls require 10.5 to 15.4VDC to operate. The positive wire lead (+) connects to power board terminal **12VDC**; the negative wire lead (-) connects to terminal **GND**.

Power Board DC Fuse

WARNING

Never replace a fuse with a higher amp rated fuse. Always use the specified fuse.

The controls circuit fuse is a standard 5 amp (tan color) automotive blade type fuse. It is located on the power board, labeled **F1**.

DC Power Wiring Requirements

WARNING

Never use undersized wires to supply DC power to the power board. The use of undersized wires can cause low voltage and high amp draw conditions. The high amp draw caused by a circuit using undersized wires will cause the wire to overheat and creates an electrical fire hazard.

2-Way Models

18 AWG is the minimum AWG size wire that can be used for connecting DC power to 2-way models. The in-line fuse for overload protection must not exceed 6 amps.

3-Way Models

The distance between the RV DC power source and the power board DC power connection terminals dictates the AWG size wire that must be used. If the distance from the DC power source is:

- 20 feet or less – 10 AWG or a larger gauge wire must be used. The size fuse for circuit overload protection must not exceed 30 amps.
- Over 20 feet – AWG 8 or a larger wire gauge must be used. The size fuse for circuit overload protection must not exceed 40 amps.

AC/DC Converter as Power Source

The power board must be supplied with 12VDC only from the filtered output (battery side) of a converter.

Unfiltered voltage (commonly referred to as AC ripple) output of AC/DC converters can cause the electronic controls to set false fault codes. It can also turn off the refrigerator or prevent the refrigerator from turning off.

DC Heater–3-Way Refrigerators Only

WARNING

Do not wire the heater(s) direct! Wiring heater(s) direct bypasses control safety devices and creates the potential for an electrical fire.

The DC heater, shown in Fig. 29, is a cartridge type heater. The DC heater is rated for 280 Watts (20 amps, at a nominal 14VDC). Heater resistance should be between 0.67 and 0.73 ohms.

NOTE

The AUTO DC and DC-Manual Mode operation maintain refrigeration only.

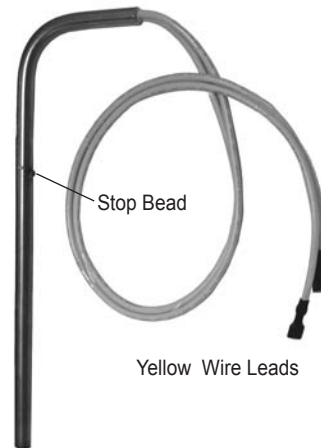

Fig. 29 - DC Heater

When AUTO DC or DC-Manual Mode does not maintain refrigeration and ventilation is correct:

- Measure DC voltage input to the power board.
- Measure the heater's amp draw.
- If amp draw is not as specified, measure the heater's resistance at ambient temperature.

The DC heater must be inserted into the heater tube until the stop bead makes full contact with the tube's rim. See Fig. 29.

DC Heater Circuit Fuse

WARNING

Never replace a fuse with a higher amp rated fuse. Always use the specified fuse.

The DC heater circuit fuse is a standard 30 amp (green) automotive blade type fuse. It is located on the DC board, labeled **F1**.

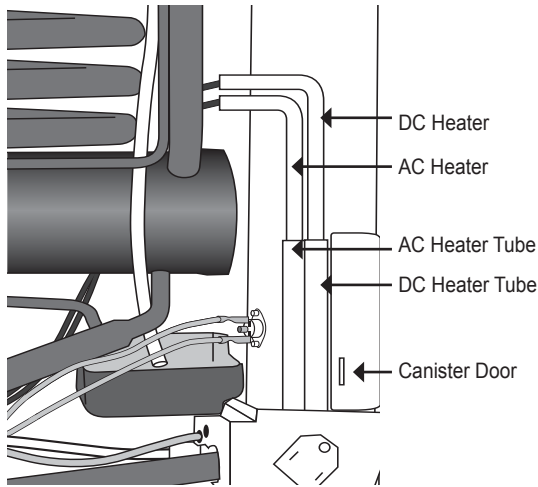

Fig. 30 - AC and DC Heaters (3-way refrigerator)

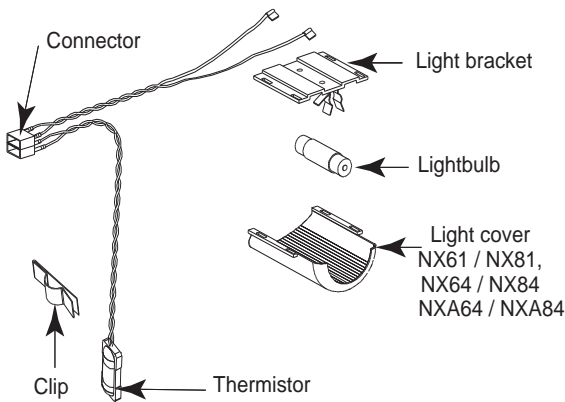

Fig. 31 - Lamp/Thermistor Assembly.

AC Power Requirements

WARNING

Electric shock hazard! The refrigerator is fed power from more than one source. Unplug the AC cord from the RV AC receptacle before servicing electrical or electronic components.

AUTO AC and AC-Manual Mode operation requires 108 to 132 VAC. AC power must be supplied through a 2 pole/3 wire/20 amp grounding type receptacle.

AC Heater

WARNING

Do not wire the heater(s) direct! Wiring heater(s) direct bypasses control safety devices and creates the potential for an electrical fire.

The AC heater, is a cartridge type heater. NX series refrigerators have a heater for rated 300 Watts (2.5 amps at 120 VAC) with a heater resistance of 46 to 51 ohms.



Fig. 32 - AC Heater.

When poor or no cooling in AUTO AC or AC-Manual Mode, is present:

1. Measure AC voltage input to the power board.
2. Measure heater amp draw.
3. If amp draw is not as specified, measure the heater's resistance at ambient temperature.

When replacing an AC heater make sure the stop bead rests fully against heater tube rim. See Fig. 32.

AC Heater Circuit Fuse

The AC circuit fuse is a fast acting 8-amp $\frac{1}{4}$ " x $\frac{1}{4}$ " AGC type. It is on the power board, labeled F2.

AC Power Cord

The AC power cord shown in Fig. 33 is used on units without ice maker. On all AC power cords the round side of the plug that connects to the power board faces the left side of the power board. The cord's grounding prong on the AC outlet connector must be left intact and never be modified or cut. The cord's ground wire (green wire) must always be fastened to the refrigerator cabinet metal plate.

Power Cord for Ice Maker Units

The AC power cord shown in Fig. 33 is used on NX64XIM / NX84XIM and NXA64XIM / NXA84XIM units (IM = ice maker). The cord has two short wire leads originating at the rear of the power board connector plug to connect the ice maker wire harness black and white leads. The smooth wire is the (hot) line voltage lead; it has a male quick-connect type terminal. The ribbed wire is the neutral lead and has a female quick-connect type terminal. Refer to Ice Maker section for ice maker wiring pictorials and diagrams.

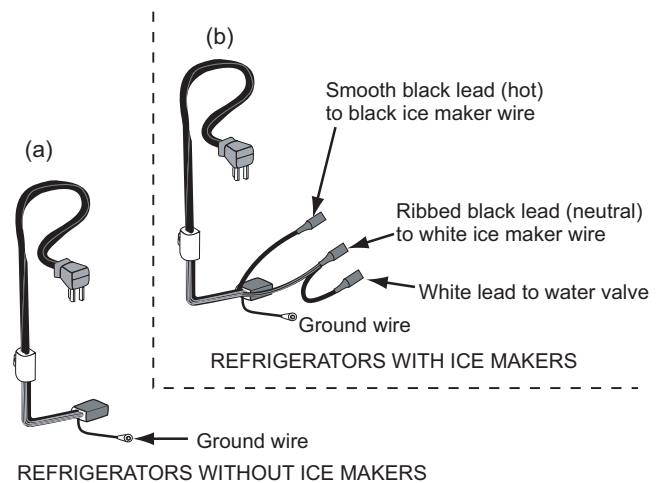

Fig. 33 - AC Power Cord.

12VDC Ventilation Fan

The 12VDC ventilation fan, shown in Fig. 34, enhances ventilation in sidewall venting installations (unit installed in RV slide out enclosures). The letter "F" in a model number is used to identify refrigerators with a factory installed 12VDC ventilation fan. All sidewall vented units must be equipped with a ventilation fan to prevent combustion gases and hot ventilation air from stagnating in the enclosure.

Ventilation fans are supplied 12VDC through power board connections. Fan operation is automatically controlled by a thermostatic switch mounted on the condenser fin. **The thermostat will be on the first fin from the left (as seen looking from the back).** See Fig. 35 and 36. The switch turns the fan on when the temperature on the first condenser fin is approximately 130 °F. The switch turns the fan off when fin temperature falls to approximately 115 °F.

NORCOLD® fan kit is wired to the power board 12VDC connections using "Y" type wire connector. The fan circuit is protected by an in-line fuse (included in the kit). The fuse, part of the fan kit wiring is a fast acting 1 amp, 1/4" x 1 1/4" AGC type. See Fig. 36. The wiring pictorial for field installed fan is shown in Fig. 37.

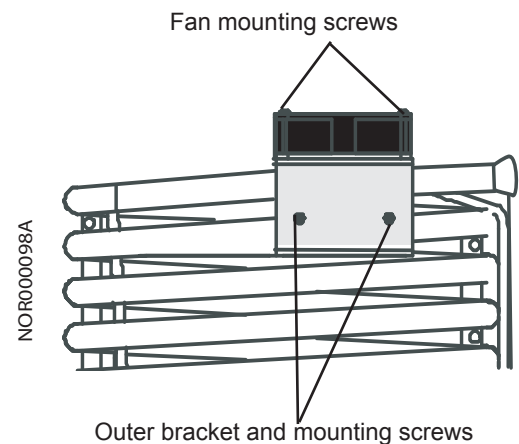

Fig. 34 - Fan Mounted on Top of Absorber Coil.

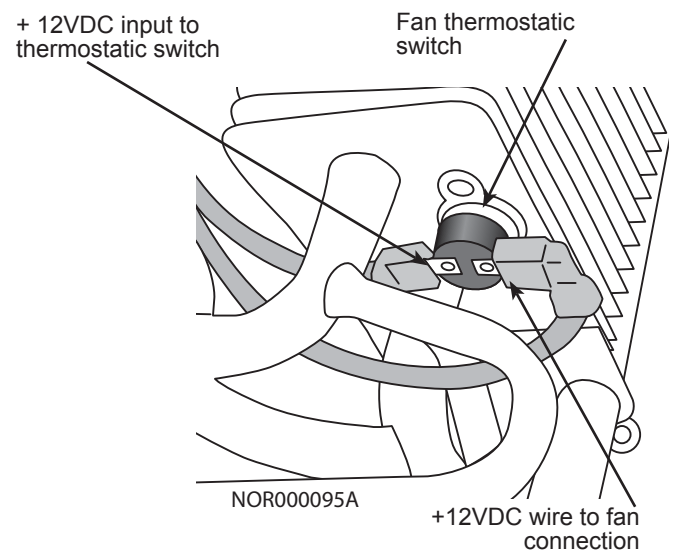

Fig. 35 - Fan Thermostat.

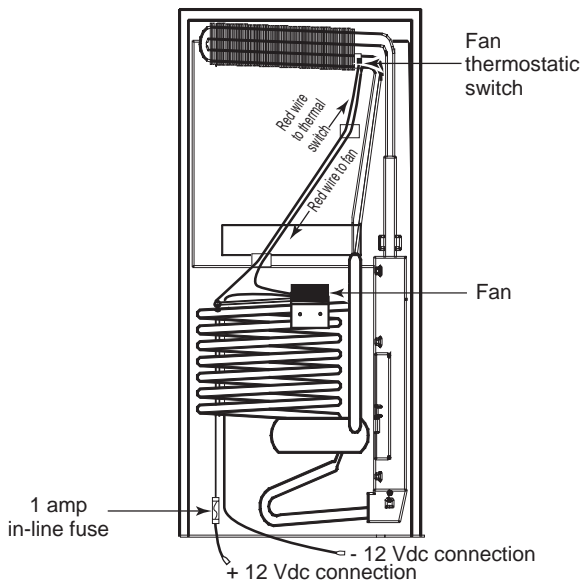

Fig. 36 - Fan with Installed NORCOLD Fan Kit

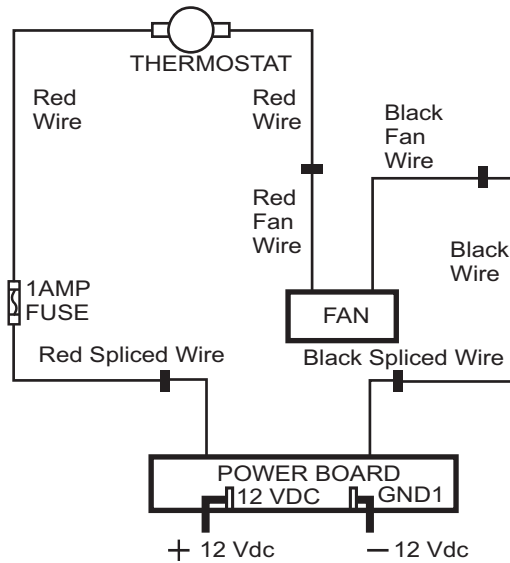



Fig. 37 - NORCOLD Fan Kit Wiring Pictorial

Low Ambient Heater (optional)

Models NXA641.3, NXA6421.3F, NXA841.3, and NXA841.3F are equipped with a low ambient heater.

Models NX641.3 and NX641.3F MAY be equipped with a low ambient heater.

 This kit supplies DC voltage to the heater any time the ambient temperature is low enough. Extended storage during cold weather will drain the vehicle batteries. To prevent battery drain, remove the 3 Amp fuse from the low ambient heater. See Fig.38.

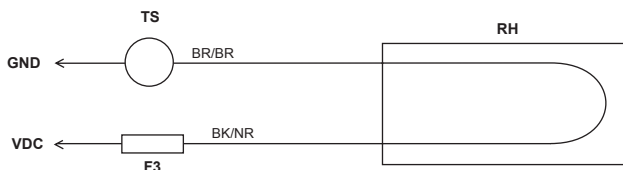
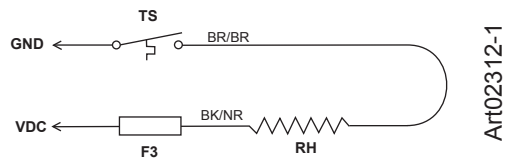

Fig. 38 - Wiring Diagram and Pictorial-Low Ambient Heater



Art02312-1

COOLING UNIT

Cooling System Monitoring

Hardware Monitoring

All NX and NXA model refrigerators are factory equipped with a high limit thermal switch mounted to the insulation canister just above the burner box. Should an abnormally high temperature occur the thermal switch will OPEN. Anytime the thermal switch opens, the electronic controls will disable ALL heat source outputs and the Open High Limit error/fault code will be displayed on the optical display (Refer to Fault Code sections).

Reset the thermal switch by pressing the red reset-button located between the two terminals on the back of the switch. Refer to Fig. 39 on page 48. When successfully reset, the resistance between the two terminals will be less than 1 ohm.

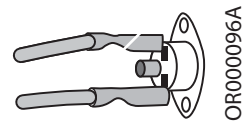

Fig. 39 - Reset Pushbutton

 **WARNING**

The thermal switch is not intended to be reset more than once. Multiple trips of thermal switch may indicate a more serious over-temperature condition inside the cooling system and must be handled by an authorized Norcold Service technician.

Troubleshooting Cooling Faults

A high percentage of cooling units returned labeled "faulty" are fully operational units. To troubleshoot cooling units see Fig. 40.

Poor or No Cooling on AC Mode

 **WARNING**

Do not work on live circuits! Turn off and disconnect AC power and DC power supplies before attempting to remove, service, or repair any of the refrigerator's electrical or electronic circuits or components.

When troubleshooting poor or no cooling in AUTO AC or AC-Manual Mode, first check AC voltage input to the power board, then check voltage output to the heater, and the heater's amperage draw.

AC voltage problems, high or low voltages, can be caused by the RV AC power supply circuit. To troubleshoot AC faults, refer to the Fault Codes section in this manual.

Poor or No Cooling on LP Gas Mode

 **WARNING**

LP gas (propane) is highly flammable and explosive! Do not smoke, light fires, or create sparks when working on the LP gas system.

Do not use an open flame to leak test any propane gas system component.

When troubleshooting poor or no cooling in AUTO LP mode or LP-Manual Mode, always check the burner flame appearance first. Most faults on LP gas operation relate to a "dirty burner."

Poor or No Cooling on DC Mode – 3-Way Models

 **WARNING**

Do not work on live circuits! Turn off AC power and DC power before attempting to remove, service, or repair any of the refrigerator's electrical or electronic circuits or components.

When troubleshooting poor or no cooling in AUTO DC or DC-Manual Mode, always check DC voltage input to the power board, voltage output to the heater, and heater amperage draw. If DC voltage input to the refrigerator is lower than 12VDC, the problem is usually related to the DC power supply source. The RV DC power supply source may not be supplying the correct voltage to the power board.

 **WARNING**

Do not operate the refrigerator if the cooling unit is leaking or leakage is suspected.

Refrigerant Leakage

Yellow powder or liquid deposits at the rear of the refrigerator or ammonia smell inside the refrigerator indicate refrigerant leakage. Exercise extreme care when handling a leaking or a suspected leaking cooling unit. The cooling system refrigerant solution consists of water, ammonia, sodium hydroxide, and sodium chromate.

Disposal of Cooling Unit

Dispose of cooling unit according to local, state, and federal guidelines and regulations. Dispose of any liquid waste or residue, according to pre-emergency planning and all applicable local, state, and federal regulations.

Do not, under any circumstances, release any waste or residue directly into sewers, or surface waters. If any liquid leaks or spills from the cooling unit, contact the nearest environmental services for guidance.

Cooling System Diagnostic Flowchart



WARNING

Do not bypass or modify the refrigerator's controls or components to diagnose the cooling system. Do not wire the heater(s) direct. The heater is supplied power through a fused circuit.



WARNING

Do not operate the refrigerator if the cooling unit is leaking or a leak is suspected.

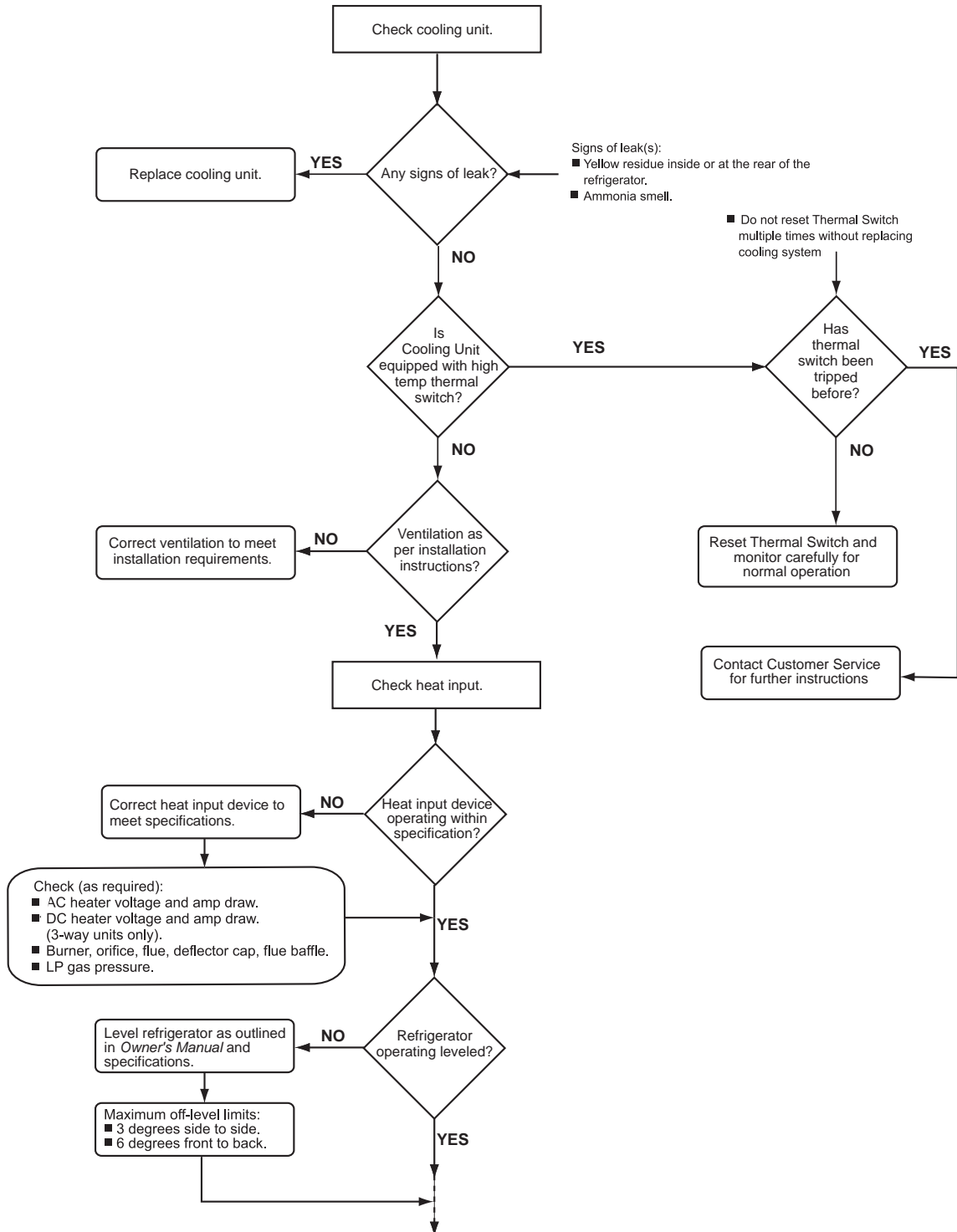

Continued on following page

Fig. 40 - Cooling System Diagnostics

 **WARNING**

Do not operate the refrigerator if the cooling unit is leaking or a leak is suspected.

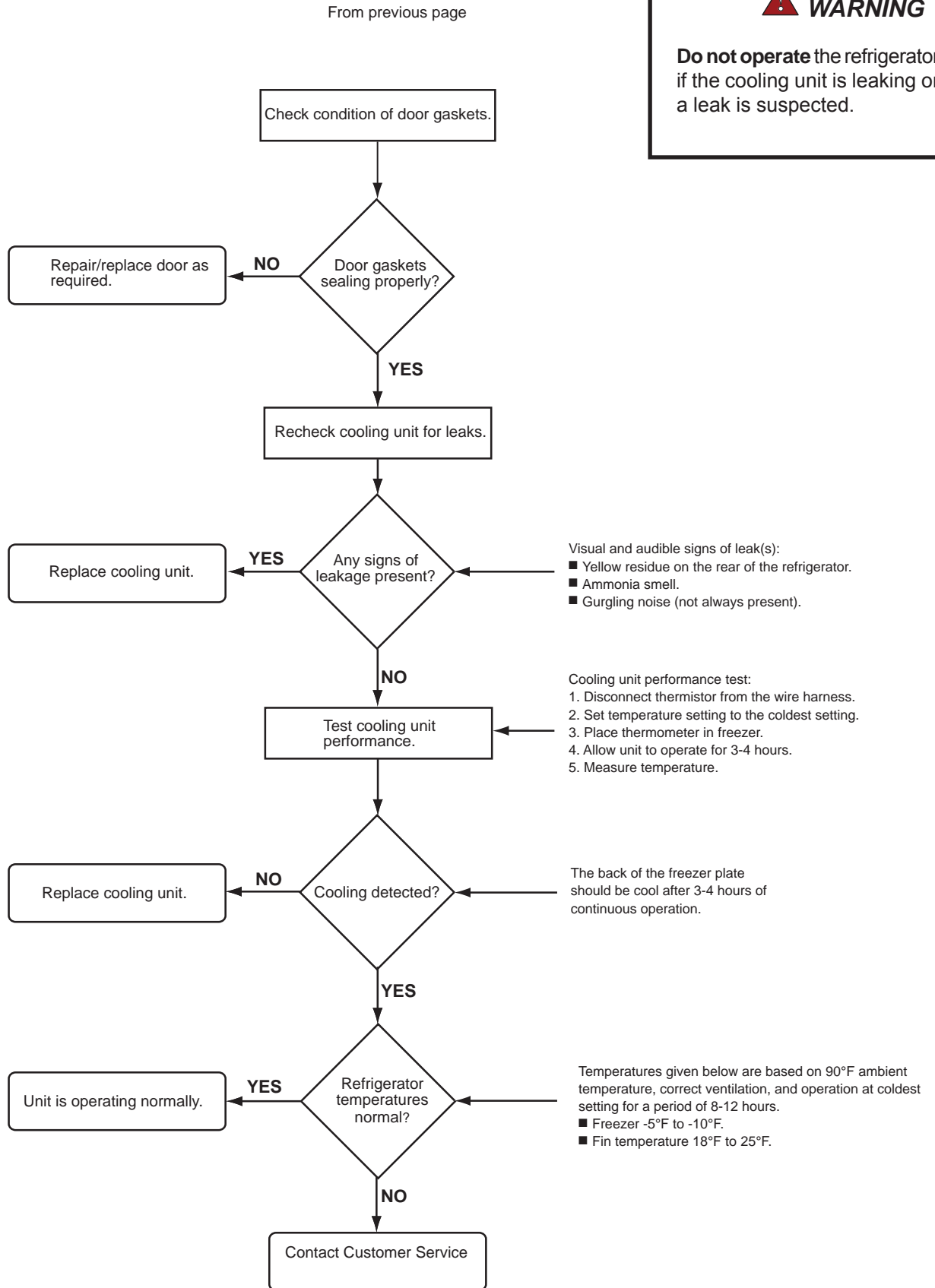

Electrical Requirements and Components

Wiring Pictorial - NX61 / NX81, NX64 / NX84, NXA64 / NXA84

- (A) AC Heater
 - (B) Light
 - (C) Thermistor
 - (D) Gas Valve
 - (E) Igniter
 - (F) Divider Heater
 - (G) * Temperature Switch
 - (H) * Temperature Switch
 - (I) * Fan
 - (J) * IM Water Line Heater
 - (K) * DC Heater
 - (L) Chassis Ground
 - (M) * DC Board
 - (N) Door Switch
 - (P) Temperature Switch
 - (1) Switched 12VDC
 - (2) Fused Continuous 12VDC
 - (3) Communications
 - (4) Display Ground
 - (5) * Auxiliary Ground
 - (6) * Auxiliary +12VDC
 - (7) Divider +12VDC
 - (8) Gas Valve +12VDC
- * Optional

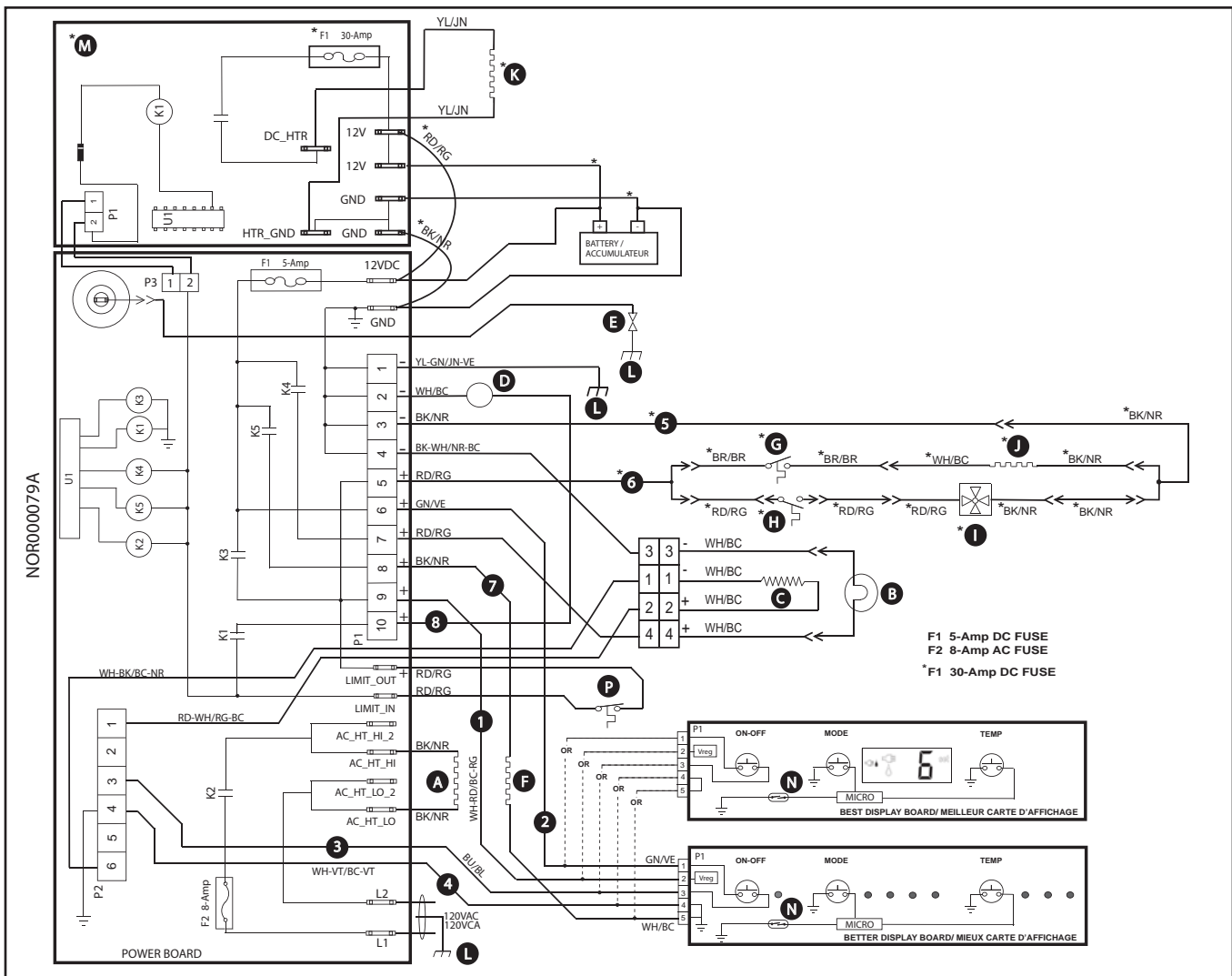

Fig. 41 - Wiring Pictorial - NX61 / NX81, NX64 / NX84, NXA64 / NXA84

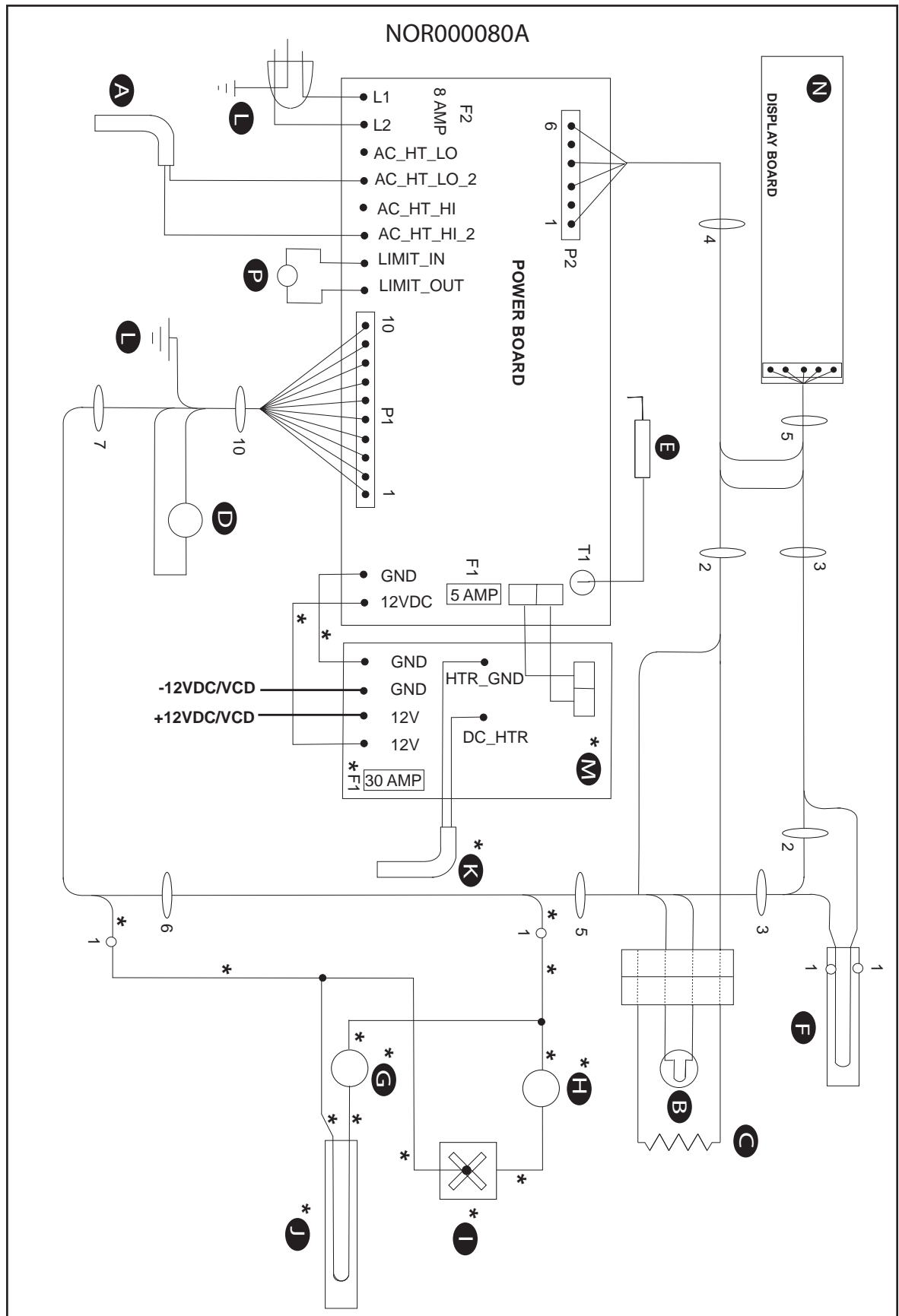

Fig. 42 - Wiring Pictorial - NX61 / NX81, NX64 / NX84, NXA64 / NXA84

MODES OF OPERATION - NX61, NX81

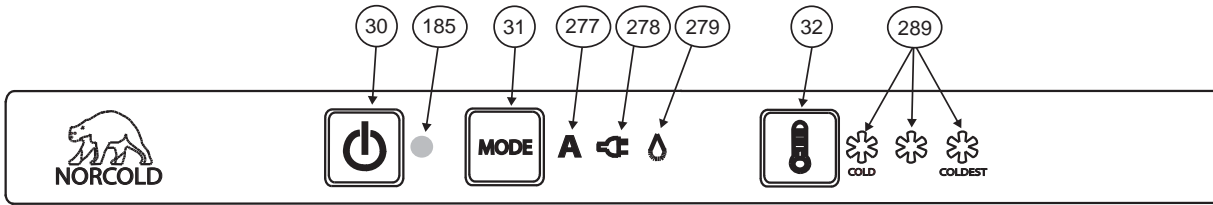

Fig. 43 - NX61, NX81 Display Board

Art02393

30 - Power On/Off Button

185 - Power On Indicator

31 - Mode Button

277, 278, 279 - Application Mode Indicator

32 - Temperature Set Button

289 - Temperature Setting

Start Up:

Before Ignition or Start Up:

- Make sure the air flow in the lower intake vent, through the refrigerator coils and condenser, and out the upper exhaust vent is not blocked or decreased.
- Make sure there are no combustible materials in or around the refrigerator.



If the gas does not ignite within 30 seconds, the gas valve of the refrigerator will automatically close and the POWER ON indicator [185] will come on solid red. To reset the controls, press and hold the POWER ON/OFF button [30] for 1 second to turn the refrigerator off and then press it again to restart the refrigerator.

1. Push and release the POWER ON/OFF button [30].
2. Select the mode of operation.
 - Push and hold the MODE button [31] to scroll through the available operation modes of the refrigerator, one after the other.
 - Or push and release the MODE button again and again to change the available operation modes of the refrigerator, one at a time.
 - As you change the mode, the applicable mode indicator(s) [277], [278], and [279] will come on.
 - Select one of three (3) modes of operation:

Mode	Meaning
AUTO mode	The refrigerator's electronic control automatically select the most efficient energy source that is available. The Auto mode indicator [277] comes on and either the AC mode indicator [278] or the gas indicator [279] comes on also.
MANUAL AC mode	The refrigerator cools using only AC electric power as the power source. The AC mode indicator [278] comes on only.
MANUAL GAS mode	The refrigerator cools using only propane gas the power source. The gas mode indicator [279] comes on only.

Table 4: NX61, NX81 Operation Modes

3. Select the temperature setting.
 - Push and hold the TEMPERATURE SET button [32] to scroll through the temperature settings, one after the other.
 - Or push and release the TEMPERATURE SET button again and again to change the temperature settings, one at a time.
 - As you change the temperature setting [289], the applicable temperature indicator(s) will come on. Select one of three (3) temperature settings:
 - Cold One temperature indicator comes on.
 - Colder Two temperature indicators come on
 - Coldest Three temperature indicators comes on.

Shut Down:

To shut down the refrigerator, push and hold the POWER ON/OFF button for one second and then release.

MODES OF OPERATION - NX64 / NX84, NXA64 / NXA84

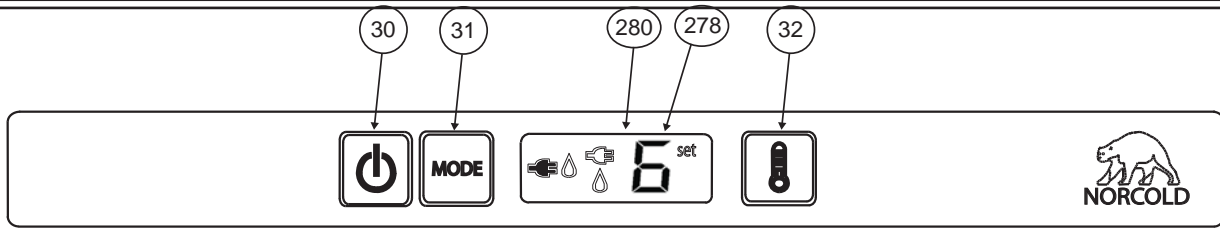

Fig. 44 - NX64 / NX84, NXA64 / NXA84 Display Board

30 - Power On/Off Button

31 - Mode Button

32 - Temperature Set Button

280 - LCD (Liquid Crystal Display)

278 - Temperature Setting

Start Up:

Before Ignition or Start Up:

- Make sure the air flow in the lower intake vent, through the refrigerator coils and condenser, and out the upper exhaust vent is not blocked or decreased.
- Make sure there are no combustibile materials in or around the refrigerator.



If the gas does not ignite within 30 seconds, the gas valve of the refrigerator will automatically close, the igniter will stop sparking, an audible alarm will sound, and the fault codes "no" "FL" will flash on the LCD [280]. To reset the controls, press and hold the POWER ON/OFF button [30] for 1 second to turn the refrigerator off and then press it again to restart the refrigerator.

1. Push and release the POWER ON/OFF button [30].
2. Select the mode of operation.
 - Push and hold the MODE button [31] to scroll through the available operation modes of the refrigerator, one after the other.
 - Or push and release the MODE button again and again to change the available operation modes of the refrigerator, one at a time.
 - As you change the mode, the applicable mode indicator will come on.

2-way Model Mode Indicators

- Auto mode AC electric [281]
- Auto mode gas [282]
- Manual mode AC electric [283]
- Manual mode gas [284]

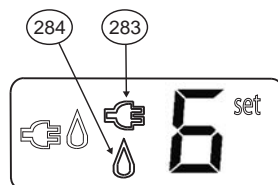
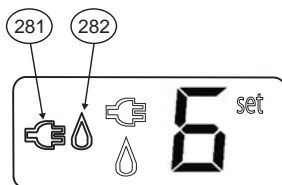

Art02398

3-way Model Mode Indicators

- Auto mode AC electric [281]
- Auto mode gas [282]
- Auto mode DC electric [285]
- Manual mode AC electric [283]
- Manual mode gas [284]
- Manual mode DC electric [286]

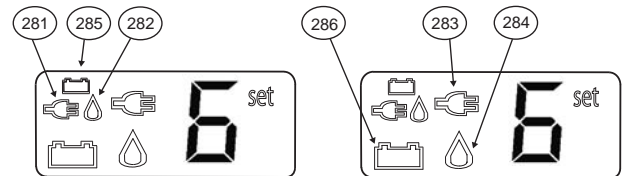

Art02399

3. Select the temperature setting.
 - Push and hold the TEMPERATURE SET button [32] to scroll through the temperature settings, one after the other.
 - Or push and release the TEMPERATURE SET button again and again to change the temperature settings, one at a time.
 - As you change the temperature setting, the applicable temperature setting [278] will be displayed on the LCD [280].
 - Select one of nine (9) temperature settings:
 - Number one (1) is the warmest temperature setting.
 - Number nine (9) is the coldest temperature setting.

AUTO mode	The refrigerator's electronic controls automatically select the most efficient energy source that is available. Either the Auto mode AC indicator [281], the Auto mode gas indicator [282], or (on 3-way models only) the Auto mode DC indicator [285] comes on.
MANUAL AC mode	The refrigerator cools using only AC electric power as the power source. The Manual mode AC indicator [283] comes on.
MANUAL GAS mode	The refrigerator cools using only propane gas as the power source. The Manual mode gas indicator [284] comes on.
MANUAL DC mode	On 3-way models only, the refrigerator cools using only DC electric power as the power source. The Manual mode DC indicator [286] comes on.

Table 5: NX64 / NX84, NXA64 / NXA84 Operation Modes

Shut Down:

To shut down the refrigerator, push and hold the POWER ON/OFF button for one second and then release.

NX64 / NX84, NXA64 / NXA84 Display Codes

Indicators and Status	Meaning
All indicators are off, except the green POWER ON indicator.	The controls have been inactive for more than 10 seconds and are in a "sleep" mode. Press and release either the MODE or the TEMPERATURE SET button to "wake" the controls for ten (10) seconds.
Green POWER ON indicator is on. AUTO indicator is on. AC indicator is on.	The refrigerator is operating in Auto mode and is using AC electric as the power source.
Green POWER ON indicator is on. AUTO indicator is on. GAS indicator is on.	The refrigerator is operating in Auto mode and is using propane gas as the power source.
Green POWER ON indicator is on. AC indicator is on.	The refrigerator is operating in Manual AC electric mode.
Green POWER ON indicator is on. GAS indicator is on.	The refrigerator is operating in Manual propane gas mode.

Table 6: NX64 / NX84, NXA64 / NXA84 Display Codes

ICE MAKER

The ice maker is a factory installed accessory. The components that support the ice maker are the water valve, water fill line, water fill tube, and the wire harness. The ice maker and components are shown in Fig. 45.

Wire Harness

The wire harness, Fig. 45(a) has four wires.

- Black—line (L) voltage with thermal fuse for ice mold overheating protection. It has an insulated female quick-connect terminal.
- White—neutral (N). The insulated male quick-connect terminal is the 120 VAC neutral (N) conductor.
- Brown—supplies 120 VAC power to the water valve solenoid during the fill cycle. It connects to water valve solenoid M terminal.
- Green—ground. Connects to the metal cabinet metal plate along with the 120 VAC power cord ground wire.

Fill Tube

The fill tube is foamed into the top of the cabinet. It is not a replaceable component.

Water Valve

Fig. 45(b) shows an ice maker solenoid water valve that has a 12VDC water line heater. The 12VDC heater is controlled by a thermostatic switch mounted on the valve's mounting bracket.

Fig. 45(c) shows an ice maker solenoid water valve without a 12VDC water line heater.

Specifications

Cycle.....	One revolution (eject and water fill)
Water fill capacity	4.7 fl. oz. (140 mL)
Ice yield	3.5 lbs/24 hrs. (Approximate)
Cycle duration.....	3.5 to 7 minutes
Voltage.....	120Vac
Amp draw	
Cycle on/heater on.....	1.6 A
Cycle on/heater off.....	0.3 A
Cycle off.....	No amp draw
Motor	1.5 W/8800 Ω
Mold Heater.....	185 W/72 Ω

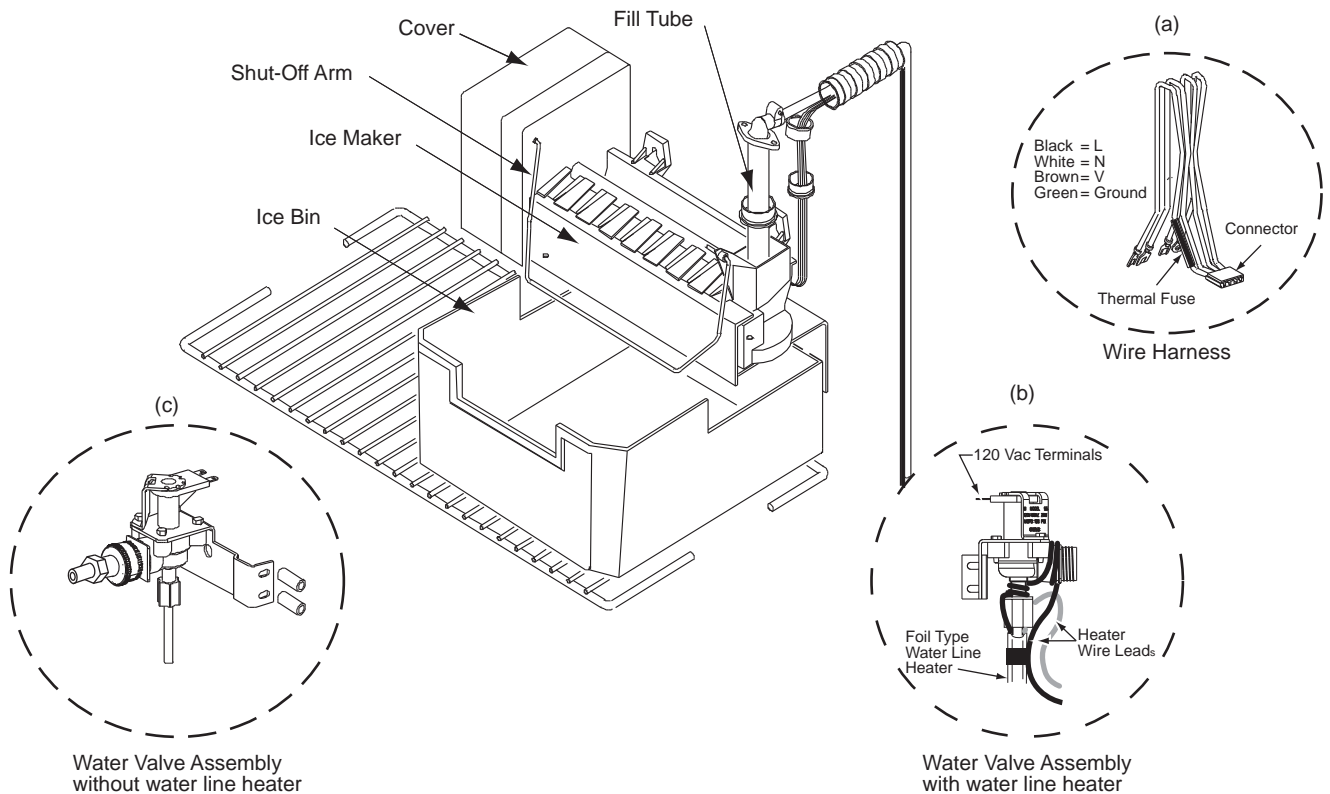

Fig. 45 - Ice Maker

Ice Maker Troubleshooting Chart

Problem	Probable Cause	Remedy
<ul style="list-style-type: none"> • No ice in mold/no ice yield. 	<ul style="list-style-type: none"> A. No AC power to ice maker B. No water available to ice maker. C. Water valve strainer clogged. D. Water valve failure. 	<ul style="list-style-type: none"> A. Check AC power supply. B. Check water supply to ice maker. C. Clean water valve inlet strainer. D. Test water valve operation; refer to page 60.
<ul style="list-style-type: none"> • Ice in mold/no ice yield. 	<ul style="list-style-type: none"> A. No AC power available. B. Shut-off arm in the OFF position. C. Mold over filled. D. Water valve washer seal damaged. 	<ul style="list-style-type: none"> A. Check AC power supply. B. Lower the shut-off arm to the ON position. C. Check position of water valve orifice. D. Replace water valve.
<ul style="list-style-type: none"> • Mold dripping water/ overflowing. 	<ul style="list-style-type: none"> A. Water fill adjustment screw set incorrectly. B. Water valve washer seal damaged. 	<ul style="list-style-type: none"> A. Reset the water adjustment screw. B. Replace water valve
<ul style="list-style-type: none"> • Ice maker will not cycle, AC power available. 	<ul style="list-style-type: none"> A. Mold heater failed open. B. Motor failure. C. Mold thermostat failure. D. Wire harness thermal fuse open. 	<ul style="list-style-type: none"> A. Replace ice maker. B. Replace ice maker. C. Replace ice maker. D. Replace harness.

Replacing the Ice Maker

To remove the existing ice maker (see Fig. 46):

1. Unplug the refrigerator or ice maker AC power cord from the RV AC power receptacle.
2. Remove the freezer bolts along with the flat washers (two, 1 inch long screws).
3. Remove two upper mounting screws (two, 1/2 inch screws).
4. Unplug the wire harness from the ice maker.
5. Remove two mounting plate screws (two Phillips head screws), then remove the mounting plate.
6. Remove the shut-off arm and install it in the new ice maker.
7. Attach the mounting plate to the bottom of the new ice maker (two Phillips head screws). Tighten screws firmly.
8. Plug the wire harness into the ice maker. Make sure the plug locking tab locks the plug in the connector.
9. Attach the mounting plate to the freezer plate (two, 1 inch long screws with washers)
10. Attach the upper mounting brackets to the freezer plate (two, 1/2 inch screws).
11. Tighten all screws firmly.
12. Plug the AC cord in the RV AC power receptacle.

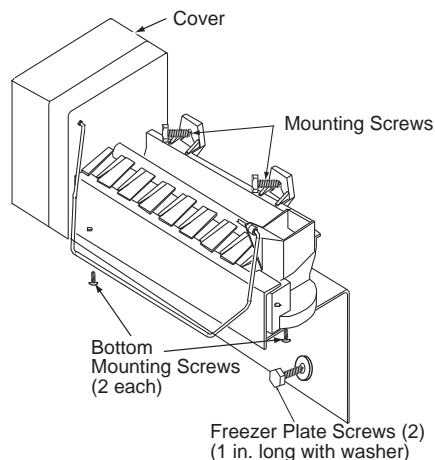

Fig. 46 - Ice Maker Mounting Hardware

Cycle Test

Cycle testing the ice maker will confirm if the mold heater energizes and motor complete a full cycle. However, if the ejector fingers are trapped in the ice allow the ice to partially thaw before cycle testing the ice maker.

To cycle test the ice maker:

1. Shut off the water supply to the ice maker water valve.
2. Remove the ice maker cover.
3. Place the shut-off arm in the ON position (down).
4. Make sure 120 VAC is available to the ice maker.
5. Measure voltage across test points L and N. See Fig. 47. Voltage reading should be between 108 to 120 VAC. If no voltage present, check the continuity of the ice maker wire harness.
6. Short terminals T and H. An insulated jumper wire 14 AWG with 1/2 inch stripped ends is recommended. See Fig. 48. The following events should take place during the cycle:

NOTE

Shorting test points T and H will start the cycle. Remove the jumper wire from test points T and H when a click sound is heard or immediately after 15 seconds of shorting terminals T and H.

WARNING

Burn hazard! The mold heater will heat the bottom of the mold. Handle or grasp the ice maker by its sides when performing a cycle test.

- a. The mold heater begins to heat the mold.
 - b. The ice maker ejector starts to cycle.
 - c. About 15 seconds into the cycle, the thermostat produces a "click" sound.
 - d. As the ejector fingers reach the 12 o'clock position the water valve energizes.
7. If the water valve does not remain energized between 3.5 and 7.5 seconds, see Water Fill Adjustment.

NOTE

Remove the jumper wire immediately after hearing the "click" sound or 15 seconds after shorting terminals T and H. Failing remove jumper wire will cause damage to the heater and/or overheat the mold, which will ruin the ice maker.

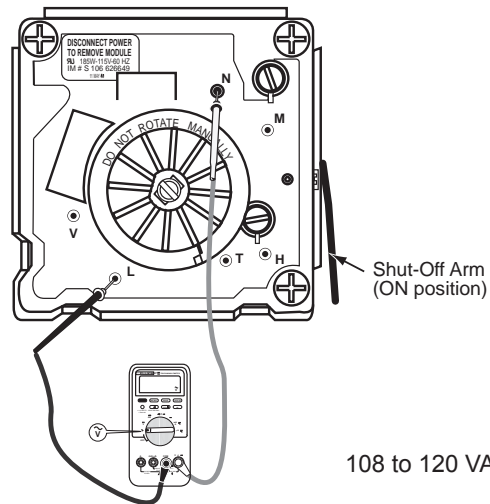

108 to 120 VAC

Fig. 47 - Test points L and N.

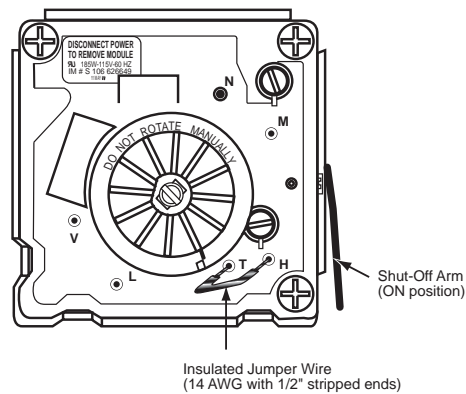

Insulated Jumper Wire
(14 AWG with 1/2" stripped ends)

Fig. 48 - Test points T and H.

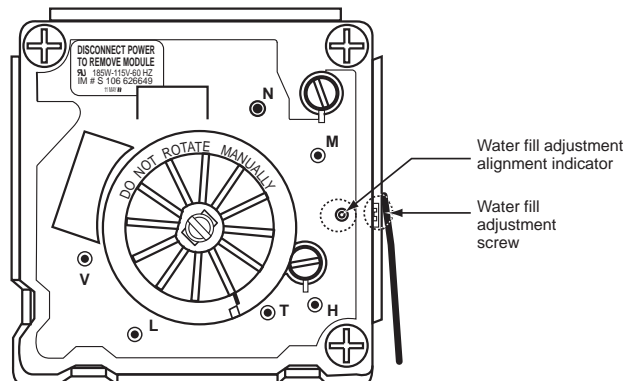

Fig. 49 - Water Fill Adjustment Screw and Indicator.

Water Fill Adjustment

The ice maker water fill adjustment is factory set. Tampering with the water adjustment screw may cause the water valve to close before the mold is filled to normal level or exceed the mold water level. If the valve closes before the mold is filled to capacity, the ice cubes produced will be small and thin. If the water valve remains open longer than 7.5 seconds, the water level in the mold will be above the normal level. The excess water above the normal level tends to form a layer of ice that fuses all the ice cubes. The surface tension created by the extra layer of ice prevents the ejector from removing the ice cubes from the mold.

The water fill adjustment screw location is shown in Fig. 49. Turning the screw 1/4 turn in a clockwise or counterclockwise direction varies the fill by 0.34 fl. oz. (10 mL).

Turning the screw varies the location of the adjustable internal copper contact. The small hole in the contact should be in the center of the module housing hole (alignment indicator). With the hole centered, the water valve should remain open approximately 7.5 seconds.

Low Ice Yield

The thermostat initiates the cycle when the temperature of the mold is approximately 14°F. For the ice maker mold to reach 14°F, the freezer temperature must be maintained at or below 0°F. In gas absorption refrigerators low ice yield may be caused by poor cooling unit ventilation, which directly affects freezer temperature.

Water Valve Operation Test

Test water valve operation by shorting points V and L using an insulated jumper wire. See Fig. 50. Shorting points V and L energizes the valve's solenoid. When energized, the solenoid will make an audible click and continuous buzzing sound until the jumper wire is removed.

Water Valve Solenoid Resistance

Always disconnect the ice maker AC power cord before taking resistance readings on the water valve solenoid.

To contact test points V and N, the resistance meter's probes must be at least 1/2 inch long. See Fig. 51.

- Resistance values: 295 to 360 Ω.
- OL: check for loose wire harness connections at the water valve or an open solenoid coil.
- 00.0 Ω: Indicates a short between the ice maker and the water valve.

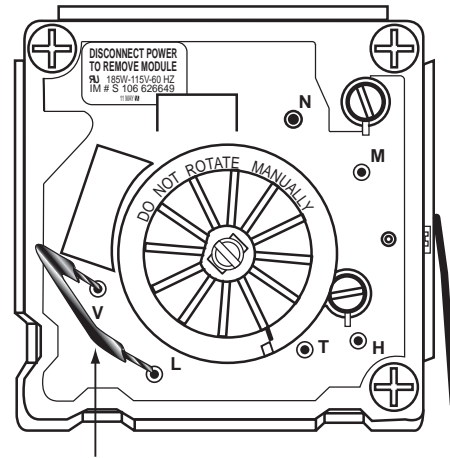

Insulated jumper wire
(14 AWG with 1/2-stripped ends)

Fig. 50 - Energize water valve through test points V and L

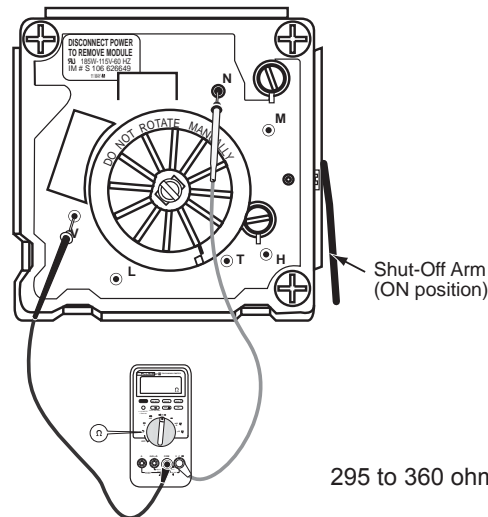

295 to 360 ohms

Fig. 51 - Measure water valve solenoid resistance

Mold Heater Resistance Check

Unplug the ice maker AC power cord before taking any resistance readings on the ice maker.

To contact test points L and H, the test probes must be at least 1/2 inch long. Connect the multimeter's probes as shown in Fig. 52.

- Resistance values: 71 to 79 Ω .
- Replace the ice maker if the mold heater resistance is not within 71 and 79 Ω .

Checking Voltage at Motor Terminals

Make sure AC power is available to the ice maker before taking voltage readings across test points N and M.

To contact test points N and M, the test probes must be at least 1/2 inch long. Fig. 53 shows the multimeter connections to points N and M to measure voltage. The voltage across points L and M should be 108 to 132 VAC. If no voltage is detected, replace the ice maker.

Winterizing the Ice Maker Water

To winterize the ice maker:

1. Shut off the RV water supply to the ice maker.
2. Lower the ice maker shut-off arm to the off position.
3. Disconnect the garden hose adapter from the water valve.
4. Disconnect the ice maker water supply line from the water valve. Do not unwrap the water line heater wire from the water valve outlet connection.
5. Allow the water to drain from the RV water supply line and the ice maker water line.
6. Protect connections by bagging and taping RV water supply connection, the ice maker water line connection, and the water valve connections

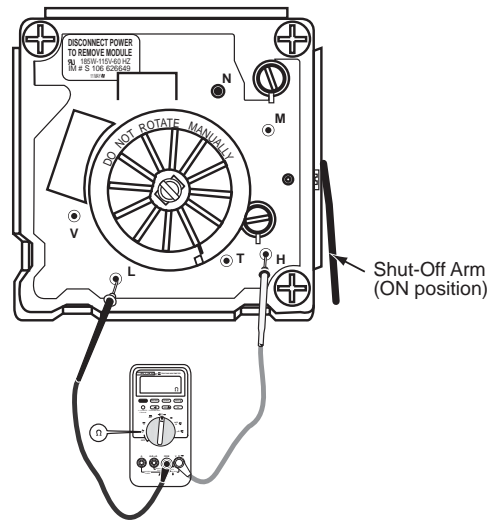

Fig. 52 - Measure mold heater resistance

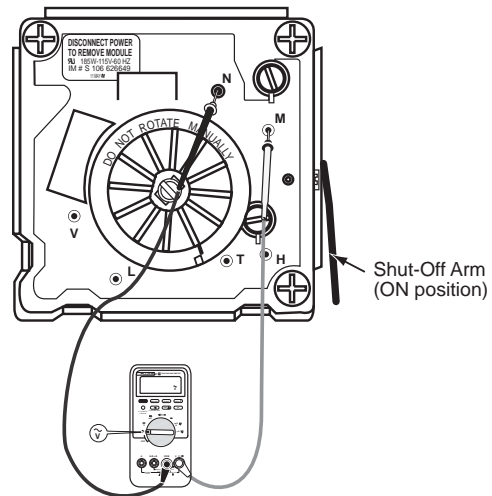

Fig. 53 - Check voltage to motor

Wiring Pictorial

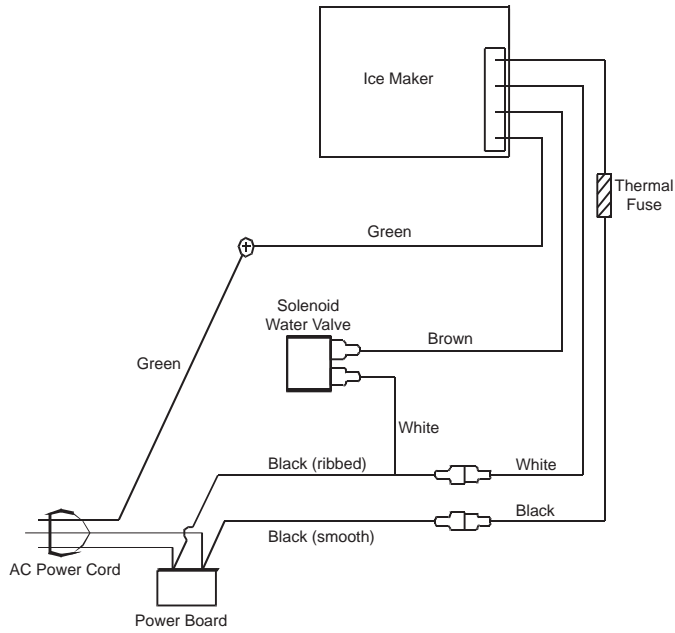

Fig. 54 - NX64IM / NX84XIM, NXA64IM / NXA84XIM – Ice Maker Wired to Refrigerator AC Cord

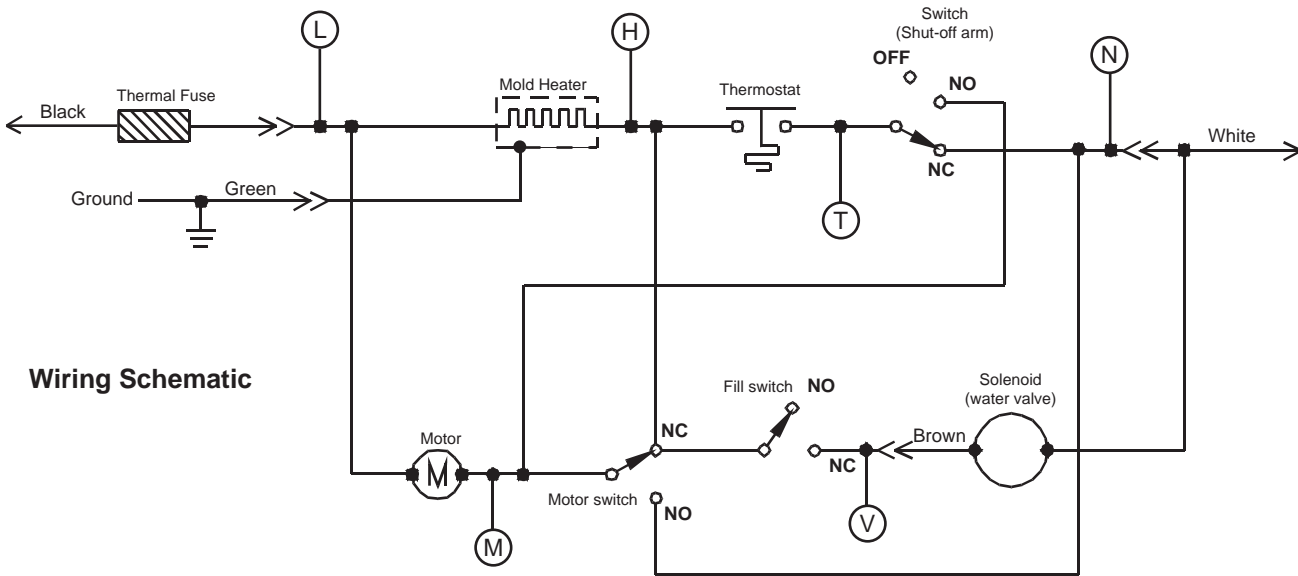

Fig. 55 - NX64IM / NX84XIM, NXA64IM / NXA84XIM – Ice Maker Wired to Unit Refrigerator Cord