

 **Weather Pro**  
*Power Awning*

 **OASIS** *Elite*<sup>™</sup>

**DIAGNOSTIC  
SERVICE MANUAL**

**REVISION:**

Form No. 3308058.019 8/04  
(Replaces 3308058.001)  
©2004 Dometic Corporation  
LaGrange, IN 46761

<b>Contents</b>	<b>PAGE NO.</b>
<b>WeatherPro &amp; Oasis Elite Symptom/Cause .....</b>	<b>3</b>
<b>SECTION 1- Wiring .....</b>	<b>4-6</b>
1.1 12VDC Supply Wire .....	4
1.2 Wire From Control Box To Awning .....	4
1.3 Wire Inside Hardware Channel (WeatherPro Only) .....	4
1.4 Motor Connection & Motor .....	5
1.5 Wire To Remote Switch .....	5
1.6 Wind Sensor Cable .....	5
1.7 Ignition Interlock wire .....	6
<b>SECTION 2- WeatherPro Wind Sensor .....</b>	<b>6</b>
2.1 Wind Sensor .....	6
<b>SECTION 3- Control Box .....</b>	<b>6-8</b>
3.1 Circuit Board .....	6-8
3.2 Control Box Rocker Switch .....	8
3.3 Wind Sensor Toggle Switch .....	8
3.4 Wiring Diagram .....	7
<b>SECTION 4- Remote Switch .....</b>	<b>9</b>
4.1 Remote Switch .....	9
<b>SECTION 5- Remote Key FOB .....</b>	<b>9</b>
5.1 Remote Key FOB .....	9
5.2 FOB Programming .....	9
<b>SECTION 6- WeatherPro Auxiliary Cable .....</b>	<b>10</b>
6.1 Auxiliary Cable .....	10
<b>SECTION 7- WeatherPro Emergency Retract Procedure .....</b>	<b>10</b>
7.1 Emergency Retract Procedure .....	10
<b>SECTION 8- WeatherPro Fabric, Roller Tube, Torsion Assembly &amp; Weathershield Replacement .....</b>	<b>10-15</b>
8.1 General Instructions .....	10
8.2 Awning Removal .....	10-11
8.3 Left Hand Torsion Removal .....	11-12
8.4 Right Hand Drive Assembly Removal .....	12
8.5 Fabric Removal From Roller Tube .....	12
8.6 Weathershield Assembly Removal And Replacement .....	12-13
8.7 Reinstall Fabric On Roller Tube .....	13
8.8 Torsion Assembly Replacement .....	13-14
8.9 Left Hand Torsion Assembly Winding .....	14-15
<b>SECTION 9- Wiring Diagram .....</b>	<b>15-16</b>
9.1 Wiring Diagram .....	15-16

SYMPTOM	CAUSE	LOCATION
1. Awning will not open	1. 12VDC Supply Wire 2. Fuse 3. Ignition Interlock (WeatherPro) 4. Wiring/Connections 5. Wind (WeatherPro) 6. Circuit Board Wiring 7. Motor	Section 1.1 Section 3.1.3 Section 1.7 & 3.1.7 Section 1.2, 1.3, 1.4.1, 1.5 & 9.1 Section 2.1 & 3.3 Section 3.1-3.4 Section 1.4.2
2. Awning will not close	1. 12VDC Supply Wire 2. Fuse 3. Wiring/Connections 4. Circuit Board Wiring 5. Motor	Section 1.1 Section 3.1.3 Section 1.2, 1.3, 1.4, 1.5, & 9.1 Section 3.1-3.4 Section 1.4.2
3. Awning works with remote switch but not key FOB (WeatherPro Only)	1. Distance 2. Key FOB Battery 3. Key FOB Programming	Section 5.1 Section 5.1 Section 5.2
4. Awning works with key FOB but not remote switch (WeatherPro Only)	1. Circuit Board Wiring 2. Switch	Section 3.1.5 & 3.1.6 Section 4.1
5. Awning will open when ignition key is in the on position (WeatherPro Only)	1. Wiring/Connections 2. Circuit Board	Section 1.7 Section 3.1.7
6. Awning works in opposite direction	1. Wiring/Connections 2. Circuit Board Wiring 3. Switch	Section 1.5 Section 3.1.5 & 3.1.6 Section 4.1 & 3.2
7. WeatherPro awning works when Oasis Elite should or visa versa	1. Wiring/Connections 2. Circuit Board Wiring	Section 1.2 & 9.1 Section 3.1.4
8. Awning does not close during high wind conditions	1. Wind Sensor Switch Off 2. Wind Sensor Wiring 3. Wind Sensor	Section 3.3 Section 1.6 & 3.1.8 Section 2.1
9. Beeping sound coming from control box (WeatherPro Only)	1. Wind Sensor Wiring 2. Wind Sensor	Section 3.1.8 & 3.1.9 Section 2.1
10. Auxiliary Close/Open awning (WeatherPro Only)	1. No 12VDC in RV	Section 6.1
11. Emergency Close Awning (WeatherPro Only)	1. No 12VDC Available 2. Awning Inoperable	Section 7.1 Section 7.1
12. Fabric, Roller Tube, Torsion Assembly and Weathershield Replacement (WeatherPro Only)		Section 8.1- 8.9

## SECTION 1 WIRING

### 1.1 12VDC Supply Wire

1.1.1 The 12VDC supply wire must be run from the 12VDC supply source to the Control Box. It is recommended that these wires be RED+ and Black- 12 gauge wires. This needs to be on a separate 15 amp circuit. See FIG. 1.1A & 1.1B.

1.1.2 To ensure proper operation, the control box must have a minimum of 12.5 VDC at the control box during operation. Check voltage output on the Red and Black wire at the control box. If voltage is below 12.5, check voltage at supply, If OK it may be necessary to increase the wire size going to the control box. See FIG. 1.1A.

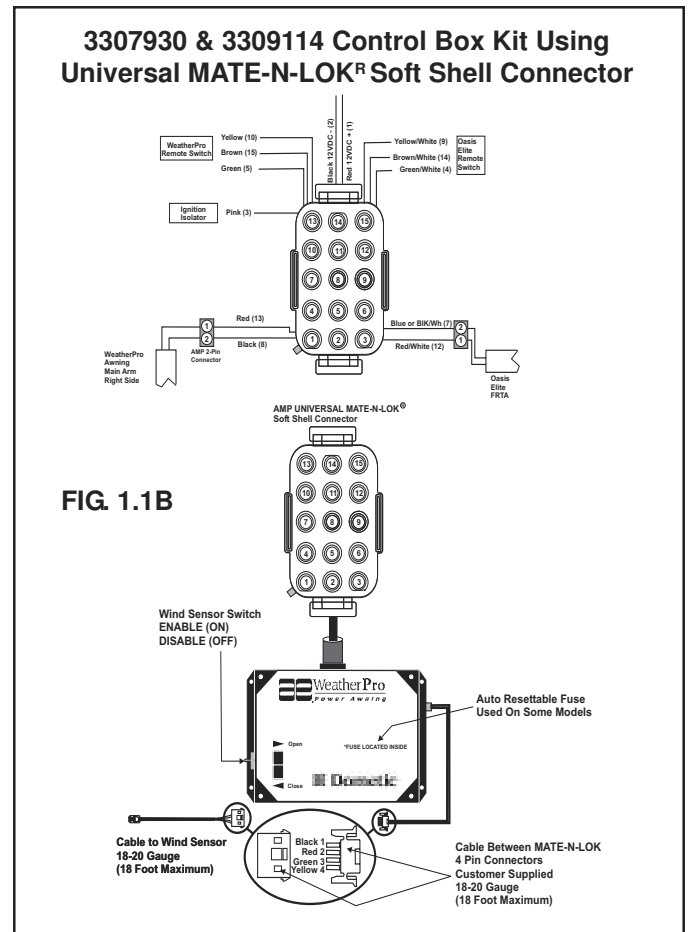
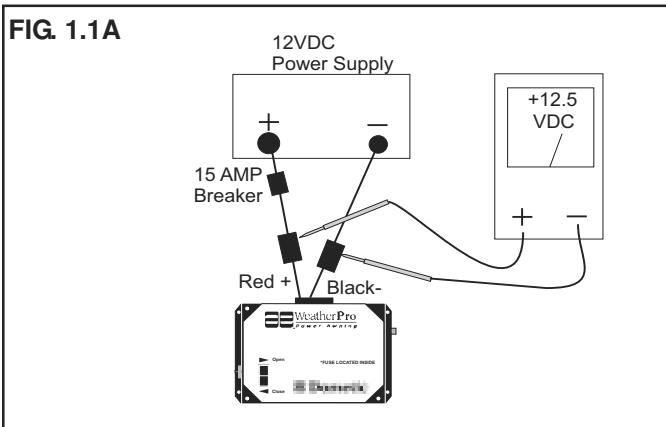

FIG. 1.1B

1.1.3 If the control is the part number 3307930 & 3309114 the voltage can be checked on the pins (1) and (2) of the 15 pin MATE-N-LOK® plug. Pin (1) is DC+ and pin (2) is DC-. See FIG. 1.1B

### 1.2 Wire From Control Box to Awning. Arm Assembly (WeatherPro) and Awning Motor (Oasis Elite)

A Red and Black Wire (WeatherPro) Red/White and Blue or Black/White wire (Oasis Elite) of adequate size must be run between the control box and the awning. To avoid voltage drop follow the chart below to determining the proper size wire to be used.

Wire Length	Wire Size
10' & Under	14 Gauge
11' to 30'	12 Gauge
Over 30'	10 Gauge

Location	Pin Functions	Wire Color	Wire Size
Pin 1	12+VDC	Red	12 Gauge
Pin 2	12- VDC	Black	12 Gauge
Pin 3	Ignition Isolator	Pink	16 Gauge
Pin 4	Oasis Elite Remote Switch	Green/White	16 Gauge
Pin 5	WeatherPro Remote Switch	Green	16 Gauge
Pin 6	Blank		
Pin 7	Oasis Elite Motor (-12VDC)	Blue or Blk/Wh	See chart in 1.2
Pin 8	WeatherPro Motor (-12VDC)	Black	See chart in 1.2
Pin 9	Oasis Elite Remote Switch	Yellow/White	16 Gauge
Pin 10	WeatherPro Remote Switch	Yellow	16 Gauge
Pin 11	Blank		
Pin 12	Oasis Elite Motor (+12VDC)	Red/White	See chart in 1.2
Pin 13	WeatherPro Motor (+12VDC)	Red	See chart in 1.2
Pin 14	Oasis Elite Remote Switch	Brown/White	16 Gauge
Pin 15	WeatherPro Remote Switch	Brown	16 Gauge

### 1.3 Wire Inside Hardware Channel (WeatherPro Only)

To make the connection between the wire run in 1.2 and the awning motor there is a cable run in the hardware from the bottom to the top. Check this wire for pinches or breaks. If wire is defective replace with new harness. See FIG. 1.3.

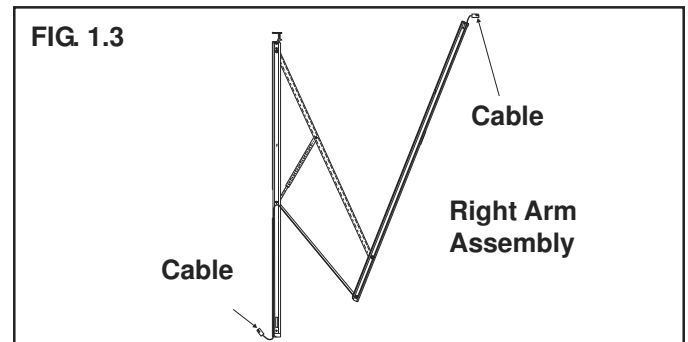
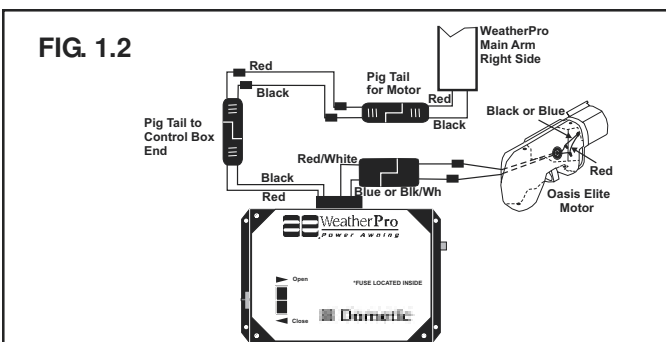

## 1.4 Motor Connection & Motor

- 1.4.1 The awning motor is connected to the hardware at the top of the awning hardware front channel. Make sure connection is tight and corrosion free.
- 1.4.2 Disconnect the motor from the hardware connection. See FIG. 1.4. Apply DC voltage directly to the motor wire connector. A minimum of 12.5 VDC is required to operate the motor. If motor does not turn it is defective and the drive assembly must be replaced.

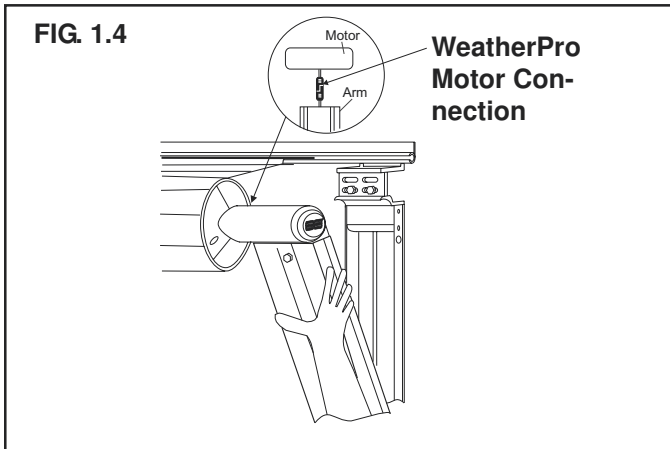

## 1.5 Wire To Remote Switch

- 1.5.1 On control 3307916.00, the remote switch is connected to the control box with three (3) 16 gauge wires. These are Brown, Yellow, Green for WeatherPro and Brown/White, Yellow/White, Green/White for Oasis Elite. The switch end of the wire will be connected to the switch by means of 1/4" insulated tab connectors. The control box end has a pig tail to connect the control box to these three wires. See switch for correct wiring. Make sure connections are tight and corrosion free. See FIG. 1.5.
- 1.5.2 The 3307930 & 3309114 Control box has three (3) 16 gauge wires coming out of a 15 pin MATE-N-LOK®. These are Brown, Yellow, Green for WeatherPro and Brown/White, Yellow/White, Green/White for Oasis Elite. See FIG. 1.1B and chart for pin location.

## 1.6 Wind Sensor Cable

The wind sensor is connected to the control box with a **FLAT** four (4) conductor cable terminated on both ends with an RJ-11-6C4P telephone connector. Maximum length is 18'. This cable is polarity sensitive and must be assembled as shown. **A standard telephone cable will not work.** Cable can be checked with a Dometic 3107127.007 cable tester. If cable is found to be defective replace with a cable no longer than 18'. See FIG. 1.6A & 1.6B

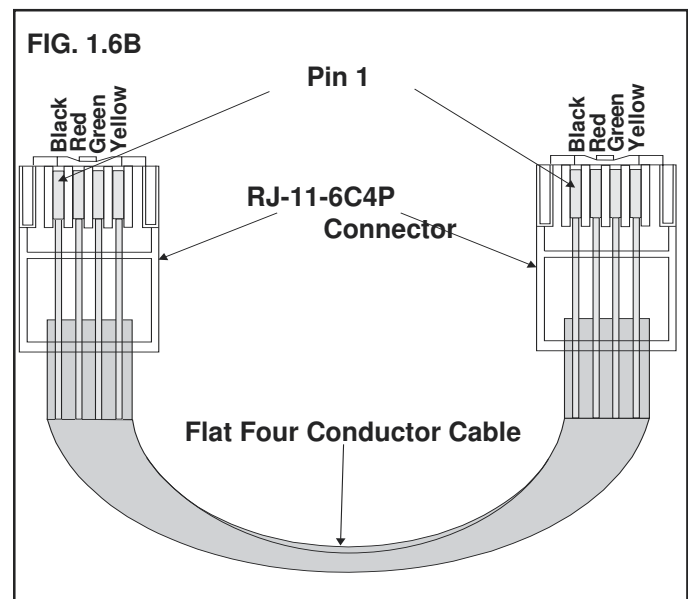
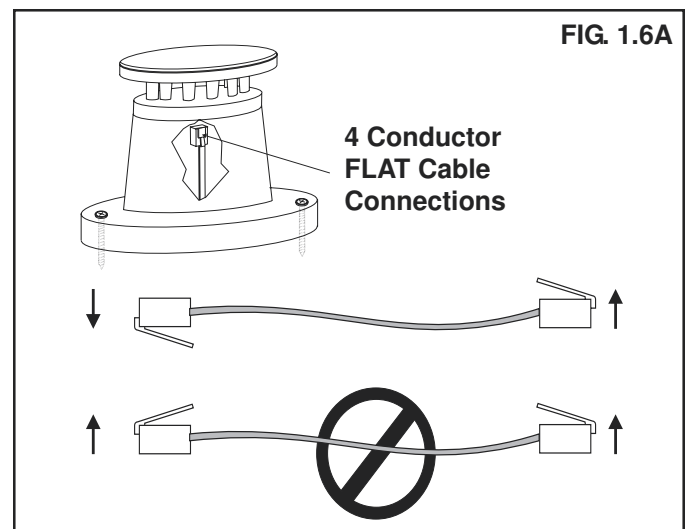
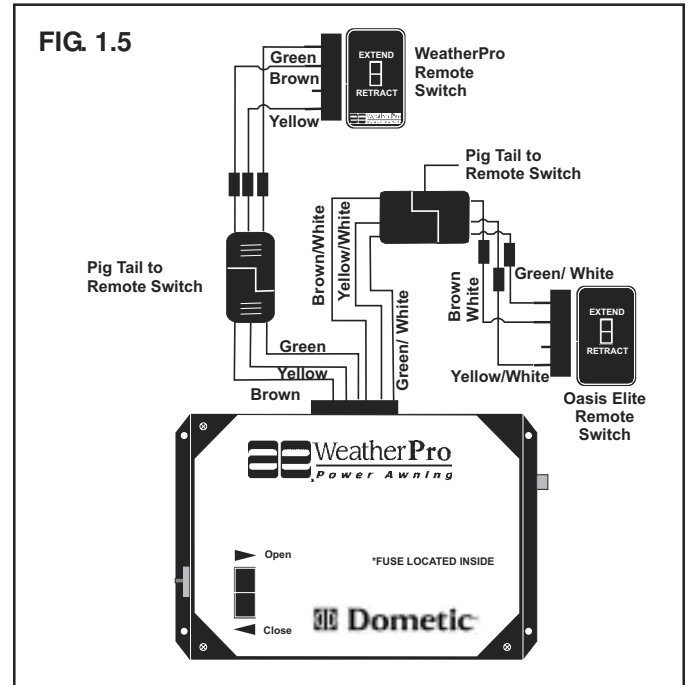

**Note:** The 3307930 & 3309114 control box uses two four pin MATE-N-LOK® connectors in conjunction with the RJ-11-6C4P plugs. If the 3107127.007 cable tester shows a defect, check these connections for problems. See FIG. 1.1B & 3.4B

## 1.7 Ignition Interlock Wire

1.7.1 When using the 3307916 Control box, the ignition Interlock wire when correctly installed will prevent the awning from opening when the ignition key is in the on position. This wire is routed between the ignition isolator (Pink) wire of the control box to the ignition isolator of the vehicle. It should be a 16 gauge wire. Make sure wire connections are tight and corrosion free. See FIGS. 1.1A & 1.7.

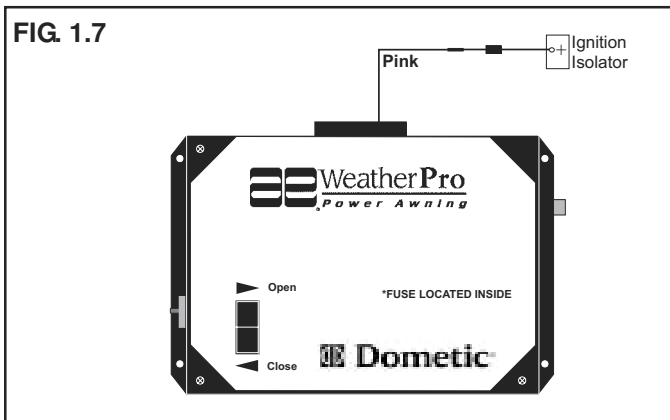

1.7.2 When the 3307930 & 3309114 control box is used the pink wire is routed from the 15 pin connector to the ignition isolator of the vehicle. It should be a 16 gauge wire. Make sure wire connections are tight and corrosion free. See FIGS. 1.1B & 3.4B.

## SECTION 2 Wind Sensor

2.1 The wind sensor monitors the wind speed (14-22 MPH) and sends a signal to the control box if wind speeds exceeds the preset setting. The correct position of the winds sensor is critical. It should be within 3 feet of the right side top mounting bracket and away from other objects. To check out the wind sensor, open the awning and place the wind sensor switch in the ENABLE (ON) position. You can create sufficient amount of wind by placing a standard hair dryer approximately 6 inches away from the wind sensor with the dryer set on **HIGH** and **NO HEAT**. The awning should close automatically. See FIG. 2.1.

## SECTION 3 Control Box

The control box is the heart of the system and contains a fuse, rocker switch, wind sensor toggle switch & circuit board.

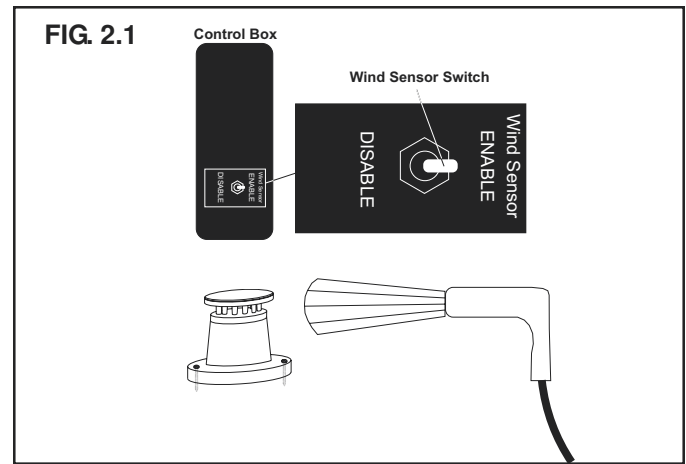

**Note:** Dometic uses two different control box configurations for the WeatherPro Awnings. The first is part number 3307916 and has 6 molded rubber plug harnesses coming out of a strain relief. See FIG. 3.4A. The second is part numbers 3307930 & 3309114 and has one (1) 15 pin MATE-N-LOK® with 13 wires going to the strain relief and it has a 4 pin connector used in the wind sensor cable. See FIG. 1.1B & 3.4B.

### 3.1 Circuit Board

The circuit board can be checked out by the process of elimination. Make sure there is 12.5 VDC going into the circuit board.

- 3.1.1 Disconnect all pig tails coming out of the (3307916) control box. Control box 3307930 & 3309114 with 15 wire plug must remain connected.
- 3.1.2 Check for 12.5 VDC (minimum) at T1 (red +) and T3 (black -) on circuit board.
- 3.1.3 Check for 12.5 VDC (minimum) on each leg of fuse. Place the negative lead of the volt meter on T3 and check each leg of the fuse with the positive lead. This should read 12.5 VDC on each leg. Replace if defective.

**Note:** Some control boxes contain an auto-reset fuse.

- 3.1.4 Check for voltage at the WeatherPro output to motor pigtail on control box 3307916 (Red & Black wire), and on the 15 pin connector on control box 3307930 & 3309114 check for voltage at Red (pins 8) and Black (pin 13).

First, press and hold the rocker switch in the open position. Place the negative lead of the digital volt meter on the Black wire position of the pigtail and the positive lead of the volt meter on the Red wire position of the pigtail. The meter should read (-) negative 12.5 VDC (minimum). Do not move the volt meter leads and press and hold the rocker switch in the close position. The meter should read (+) positive 12.5 VDC (minimum).

FIG. 3.4A

3307916 Control Box

Cable to Wind Sensor  
(18 Foot Maximum)

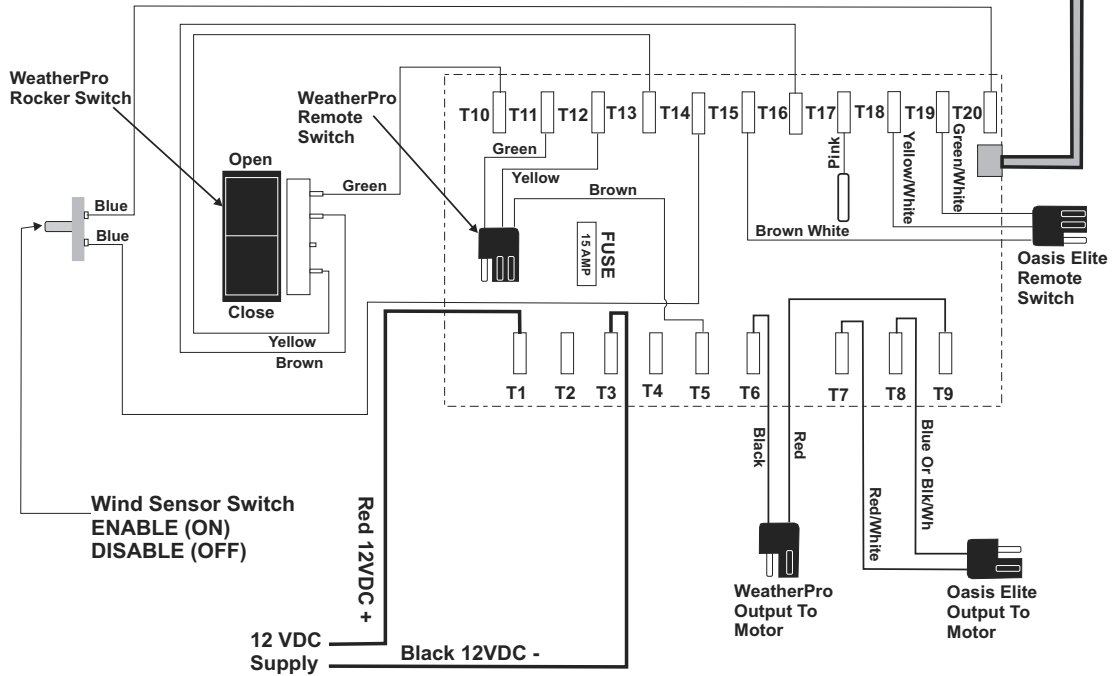
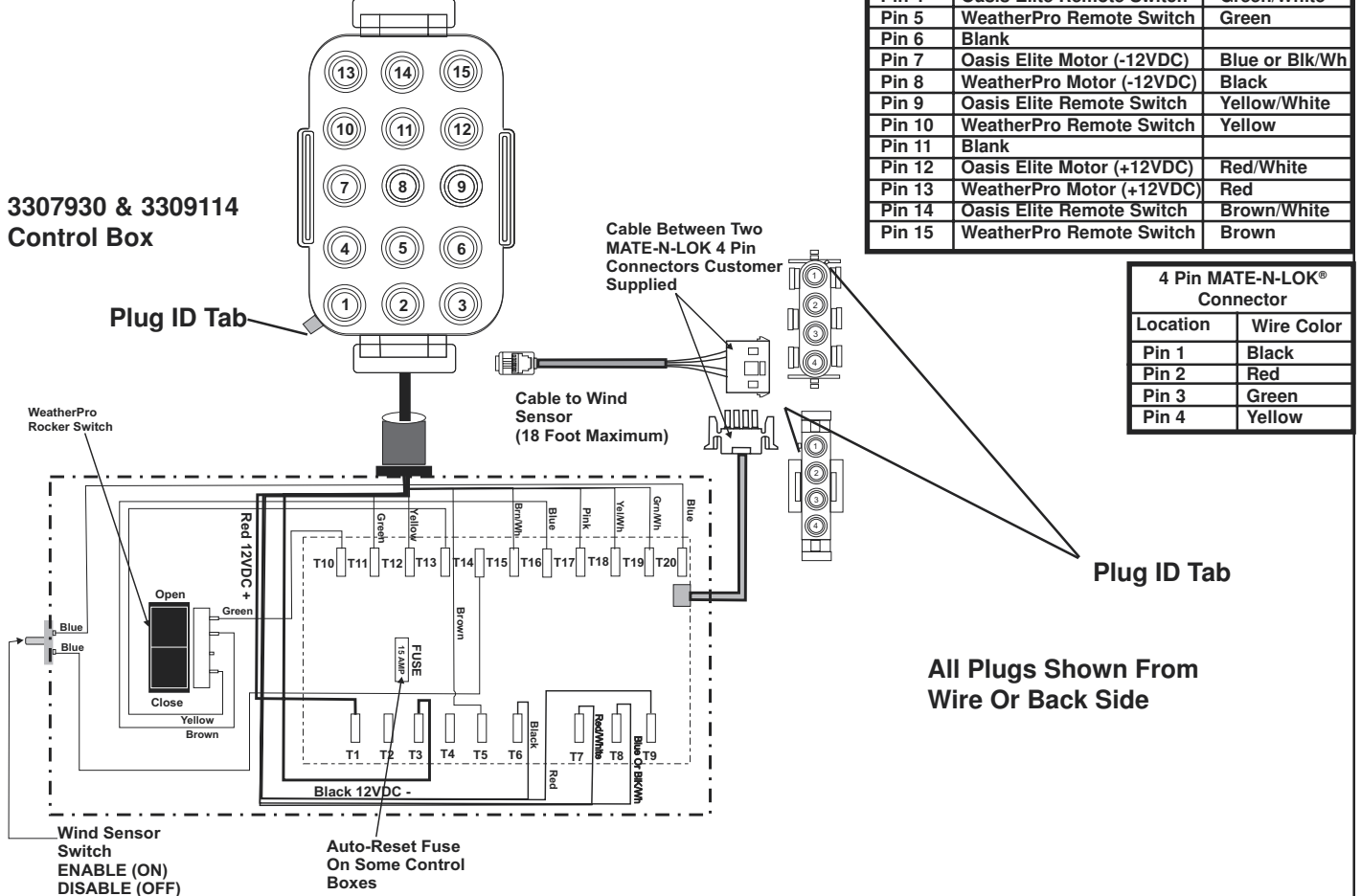

FIG. 3.4B

3307930 & 3309114  
Control Box

AMP UNIVERSAL MATE-N-LOK®  
Soft Shell Connector



15 Pin MATE-N-LOK® Connector

Location	Pin Functions	Wire Color
Pin 1	12+VDC	Red
Pin 2	12- VDC	Black
Pin 3	Ignition Isolator	Pink
Pin 4	Oasis Elite Remote Switch	Green/White
Pin 5	WeatherPro Remote Switch	Green
Pin 6	Blank	
Pin 7	Oasis Elite Motor (-12VDC)	Blue or Blk/Wh
Pin 8	WeatherPro Motor (-12VDC)	Black
Pin 9	Oasis Elite Remote Switch	Yellow/White
Pin 10	WeatherPro Remote Switch	Yellow
Pin 11	Blank	
Pin 12	Oasis Elite Motor (+12VDC)	Red/White
Pin 13	WeatherPro Motor (+12VDC)	Red
Pin 14	Oasis Elite Remote Switch	Brown/White
Pin 15	WeatherPro Remote Switch	Brown

4 Pin MATE-N-LOK®  
Connector

Location	Wire Color
Pin 1	Black
Pin 2	Red
Pin 3	Green
Pin 4	Yellow

All Plugs Shown From  
Wire Or Back Side

### 3.1.5 WeatherPro Remote Switch

- a. To check the WeatherPro (3307916 Control Box) remote switch connection (Brown, Green, & Yellow) wires in a 3 pin black molded plug, use a jumper wire and connect the Yellow to Brown. You should hear the relay click. Then connect the Green to Brown and you should hear another click.
- b. To check the 3307930 & 3309114 control box remote switch use a jumper wire and connect the yellow (pin 10) to Brown (pin 15). The relay should click inside the control box. Then connect the Brown (pin 15) to Green (pin 5) and another click will be heard.

### 3.1.6 Oasis Elite Remote Switch

- a. Check the Oasis Elite (3307916 control box) remote switch (wire in a 3 pin black molded plug), and the output to motor wire (in a 2 pin black molded plug) at the same time. The remote switch wires are Brown/White, Green/White and Yellow/White. The output to motor wire is Red/White and Blue or Black/White. Connect the positive lead of the digital volt meter to the Red/White wire position of the pigtail and the negative to the Blue or Black/White wire position of the pigtail. Jump across the Yellow/White and brown/White wire. You should hear the relay click and the voltage meter should read (–) negative 12.5 VDC (minimum). Jump across the Green/White and the Brown/White wire. You should hear another relay click and the volt meter should read (+) positive 12 VDC (minimum).
- b. Check the Oasis Elite 3307930 & 3309114 control box remote switch and the output to the motor at the same time. The remote switch wires are Brown/White (pin 14), Green/White (pin 4) and Yellow/White (pin 9). The output wires to the motor are Red/White (pin 12) and Blue or Black/White (pin 7). Connect the positive lead of the digital volt meter to the Red/White (pin 12) wire position of the pigtail and the negative to the Blue or Black/White (pin 7) wire position of the pigtail. Jump across the Yellow/White (pin 9) and brown/White (pin 14) wire. You should hear the relay click and the voltage meter should read (–) negative 12.5 VDC (minimum). Jump across the Green/White (pin 4) and

the Brown/White (pin 14) wire. You should hear another relay click and the volt meter should read (+) positive 12 VDC (minimum).

### 3.1.7 Ignition Interlock Function

- a. To check the ignition interlock function on control box 3307916 (WeatherPro Only), apply (+) positive 12 VDC to the Pink ignition interlock wire. Redo test in Step 3.1.4. There should be no readings or relay clicks when the rocker switch is placed in the open position or the key FOB open button is pressed.
- b. To check the ignition interlock function on control box 3307930 & 3309114 (WeatherPro Only), apply (+) positive 12 VDC to the Pink ignition interlock wire (pin 3). Redo test in 3.1.4. There should be no readings or relay clicks when the rocker switch is placed in the open position or the key FOB open button is pressed.

3.1.8 The circuit board contains an audible alarm to alert the user when there is a problem with the wind sensor or wind sensor cable. To test this alarm disconnect the **FLAT** four (4) conductor wind sensor cable from the side of the control box. Place the wind sensor switch in the ENABLE (ON) position. The alarm should beep from inside the control box. If this occurs under normal operation this would indicate a problem with the wind sensor wire or the connection between the wire and the circuit board or the wire and the wind sensor.

### 3.1.9 Temperature Sensing

- a. If the temperature is 30° F or less and the wind sensor switch is in the ENABLE (ON) position the alarm will sound. The awning will not open and if it is in the open position it will automatically close. Moving the switch to the DISABLE (OFF) position will stop the alarm from sounding. **See Section 1.6 and Section 2.1.**
- b. If the temperature exceeds the 105° high range the wind sensor will continue to function. The alarm will not sound. High winds (over 18- 22 MPH) will close the canopy.

## 3.2 Control Box Rocker Switch

The awning can be operated at the control box by using the rocker switch located on the cover of the control box. To test the switch, press open or close and you should hear a relay click. If after all other circuit board checks are made and no



click is present switch is defective. Replace switch.

### 3.3 Wind Sensor Toggle Switch

The toggle switch turns the wind sensor feature on and off. When the switch is in the DISABLE (OFF) position the awning will not automatically retract if threatening winds are present. When in the ENABLE (ON) position the awning will automatically retract if the wind exceeds the preset setting.

If one or more of the above tests do not perform properly the circuit board is probably defective. Replace the control box assembly.

### 3.4 Wiring Diagram (See Page 7, FIG. 3.4A & 3.4B)

## SECTION 4 Remote Switch

4.1 If awning does not work using the remote switch, disconnect both the WeatherPro and the Oasis Elite pigtail. Check for 12VDC on the control box end of the pig tail. See Section 3.1.4 and 3.1.6. If there is 12 VDC at this point depress the remote switches and listen for the relays to click. If no clicking is heard replace appropriate remote switch. See FIG. 4.1.

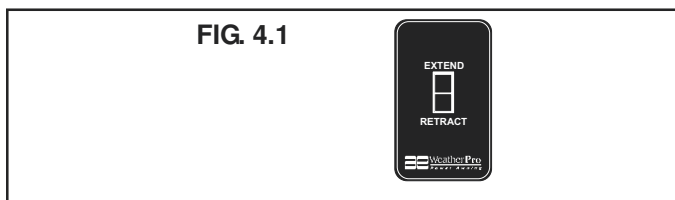

## SECTION 5 Remote Key FOB

5.1 The remote key FOB is powered by a 12 VDC type 23A battery. The operational range is up to 30 feet. This distance will vary depending on the battery condition. To change the battery, remove screw in back of key FOB and replace it with a type 23A 12VDC battery. See FIG. 5.1.

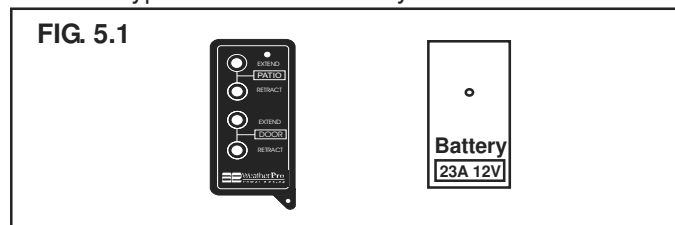

### 5.2 Programming Key FOB

**The electronic board is susceptible to static charge. Do not insert metal object inside control box. Damage to electronic board will occur if a short is created. Use only a nonconductive material to depress programming button inside control box.**

- 5.2.1 Remove four (4) screws from control box cover and lift cover to expose circuit board. See FIG 5.2.
- 5.2.2 Press and release programming button . Programming indicator light will illuminate.
- 5.2.3 Press and hold the key FOB patio awning open button for four (4) seconds.
- 5.2.4 Release the key FOB patio awning open button. This completes the programming process.
- 5.2.5 Place control box cover on control box and secure with four (4) screws .
- 5.2.6 Test awning operation.

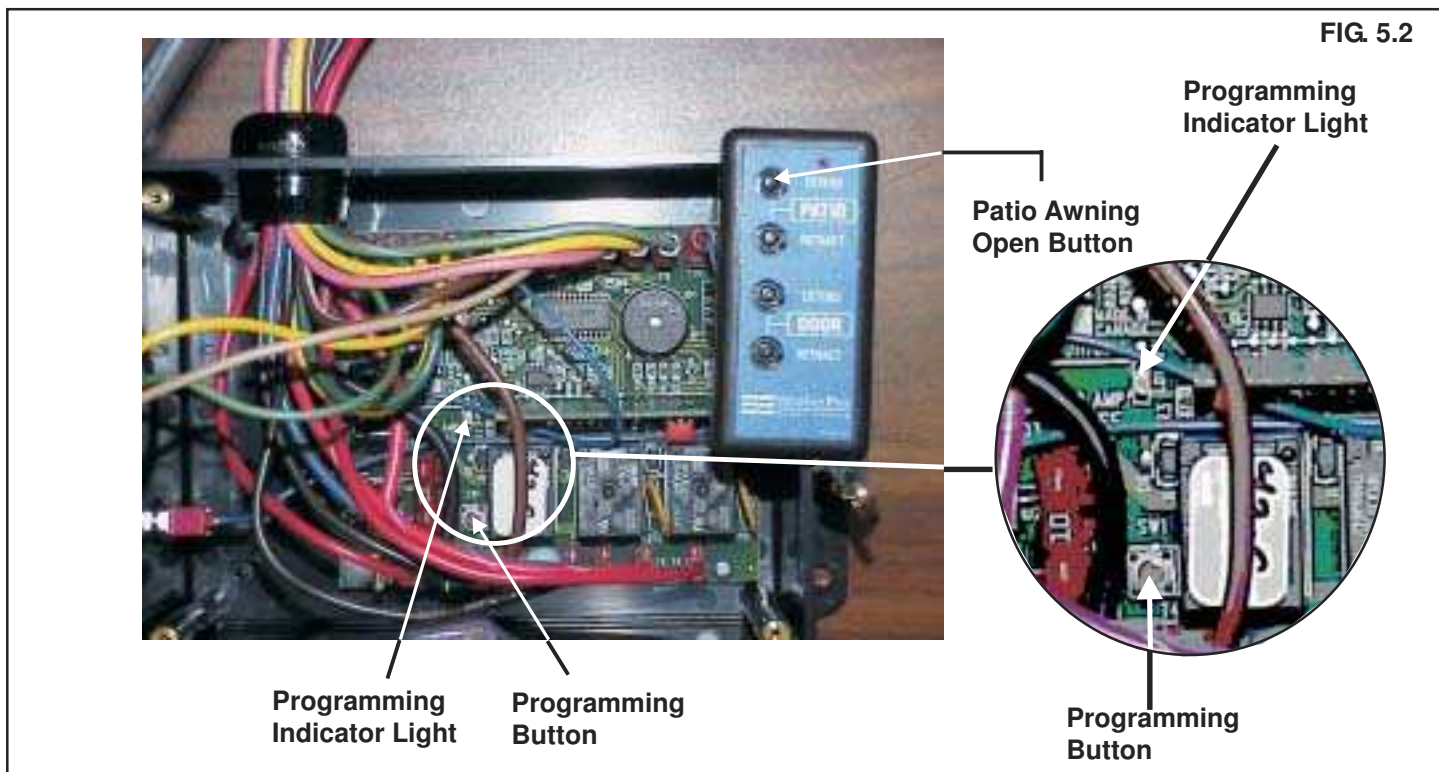

## SECTION 6 Auxiliary Cable

### In Case Of Coach 12VDC Power Failure:

6.1. The WeatherPro hardware provides an auxiliary power cable to connect the awning motor to an external 12 VDC power source in case of power failure in the coach. A good external 12 VDC power source would be an automobile battery. Access the motor and hardware cable connection located behind the wire cover at the top of the right hand arm. Gently squeeze the sides together to remove. Unplug the connection. See FIG. 6.1.

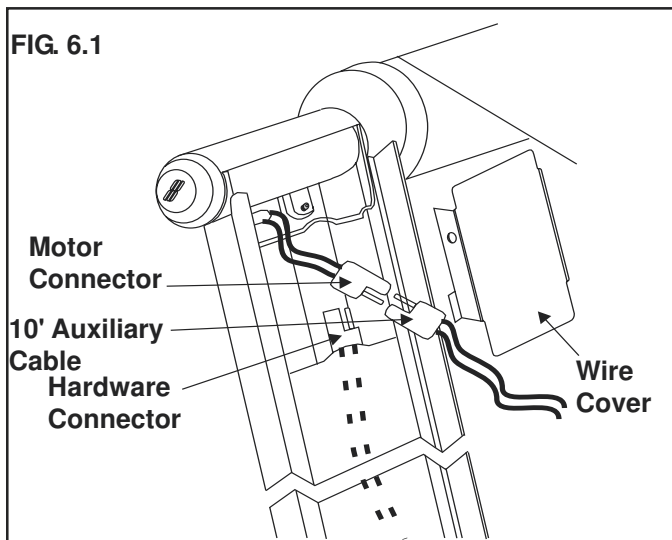

Connect the supplied 10 ft. harness directly to the motor plug. Not the one in the hardware. Connect the other end of the 10 ft. harness to a 12 VDC battery source. The red wire goes to + and the black to -. This will retract the awning. To avoid motor damage disconnect battery source immediately after awning is fully retracted. The awning can be extended by reversing the polarity. Place the red wire on the - and the black wire on the +. Again, remove wires immediately after awning is fully extended.

## SECTION 7 Emergency Retract Procedure

### To Manually Close Awning:

7.1 Slide the pull strap (provided) into the utility slot of the FRTA. See FIG. 7.1.

While one person is holding onto the pull strap, remove the bolt in the top of the right top casting. The FRTA will roll in once the bolt is removed. Walk the awning to the closed position. See FIG. 7.1.

Align hole where bolt was removed and drive bolt back into top casting to secure awning.

**Bolt must be reinstalled to prevent awning from opening during travel. Have awning serviced by a Dometic Service Center or a qualified service technician before attempting to open awning after this procedure has been performed.**

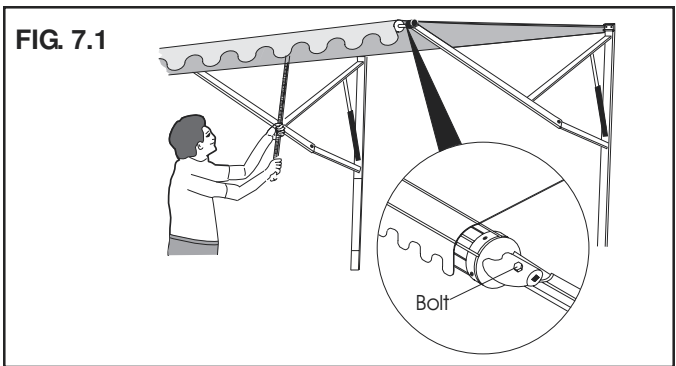

## SECTION 8 WeatherPro Fabric, Roller Tube, Torsion Assembly & Weathershield Replacement

### 8.1. General Instructions

8.1.1 The fabric roller tube assembly (referred to in the instructions as a FRTA) consists of a vinyl or acrylic fabric, roller tube, torsion assembly and weathershield. These instructions will aid the service technician to make repairs quickly and correct. The repairs must be made by a qualified service technician. Read instructions **ENTIRELY** before attempting to make repairs on the product.

### **! WARNING**

**These instructions must be read and understood before installation, adjustment, service or maintenance is performed. This unit must be installed by a qualified service technician. Modification of this product can be extremely hazardous and could result in personal injury or property damage.**

### 8.2 Awning Removal

8.2.1 In all instances of fabric, roller tube or weather shield replacement, it is necessary to unroll the fabric. A large clean and smooth work area is required to prevent damage to the fabric.

**Note:** If replacement of either torsion assembly is required awning removal from the coach is not necessary. Proceed to Sections 8.3 and 8.4.

8.2.2 Remove the TEK screws securing the awning fabric at each end of the awning rail. See FIG. 8.2.2.

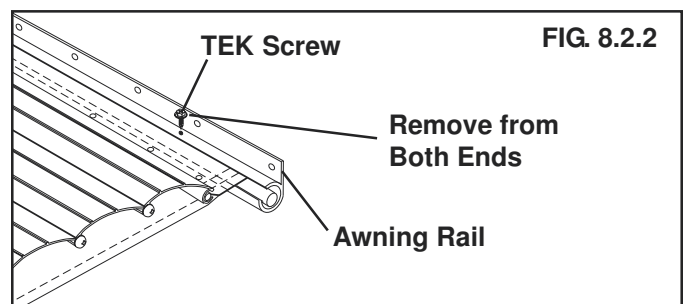

- 8.2.3 Extend or open the awning two revolutions of the FRTA. This will allow for removal of top brackets and the FTRA.
- 8.2.4 Pin the left hand torsion. See Section 8.3.
- 8.2.5 Disconnect the wire harness at the plug by the lower mounting bracket of the right arm assembly. In some installations the harness may be run through a hole in the side wall of the coach. If the hole is sealed, use a screw driver to dig out the sealant. Be careful not to damage wires, wall, or the harness assembly out of the coach.

**Note:** In some installations the wind sensor wire is routed behind the right arm assembly. Be careful not to damage.

**⚠ WARNING**

**Arms under tension from the gas strut are dangerous. Use extreme care. If not controlled the arms will extend quickly. Keep hands and clothing clear of awning arms, as personal injury may result.**

- 8.2.6 The next two steps require three people. Loosen the lag bolts holding the top and bottom mounting brackets to the coach. Push the arm assemblies closed and wrap two heavy nylon wire ties around each arm assembly to prevent them from extending during removal of the FRTA. One should be 8 inches above the front channel cover, and the other 8 inches below the top mounting bracket. Do both arm assemblies. See FIG. 8.2.6.

**Note:** Bottom brackets and back channel may be riveted.

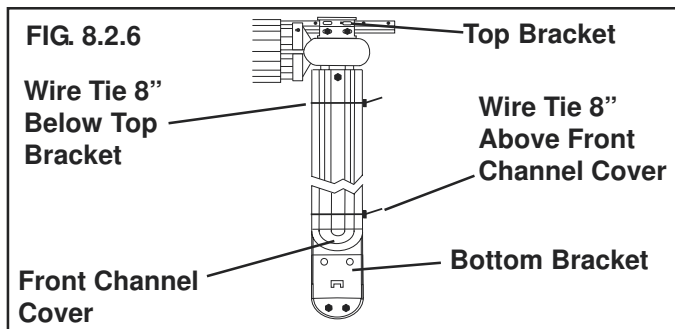

- 8.2.7 While lifting the arm assemblies to support the FRTA, remove the lag bolts holding the top and bottom mounting brackets to the side wall of the coach. Slowly walk the awning fabric out of the awning rail.
- 8.2.8 Lay the FRTA on a large clean work area to prevent damage.
- 8.2.9 Before removing the arm assemblies, you must read and understand Sections 8.3 and 8.4.

### 8.3 Left Hand Torsion Removal

**⚠ WARNING**

**Use extreme care. Springs under tension are dangerous. If not controlled they will unwind quickly. Keep hands and clothing clear of top casting, as personal injury may result.**

**Note:** If the awning is installed on a coach, complete the following steps on a step ladder with the FRTA extended two turns from the awning rail.

**⚠ WARNING**

**Severe injury can result from the rapid spin of the top casting. NEVER use bare hands to handle a top casting under spring tension.**

- 8.3.1 Before the left arm assembly is removed the torsion must be pinned to prevent uncontrolled unwinding of the spring.
- 8.3.2 Turn top casting or FRTA until the pin is parallel with the two slots in the end cap. See FIG. 8.3.2.
- 8.3.3 To pin the left hand torsion insert a 7/64" x 2-3/4" cotter pin through the end cap and torsion rod. Put a piece of tape over the head of the cotter pin to prevent it from dropping out. See FIG. 8.3.2.

**FIG. 8.3.2 Left Hand Torsion Shown**

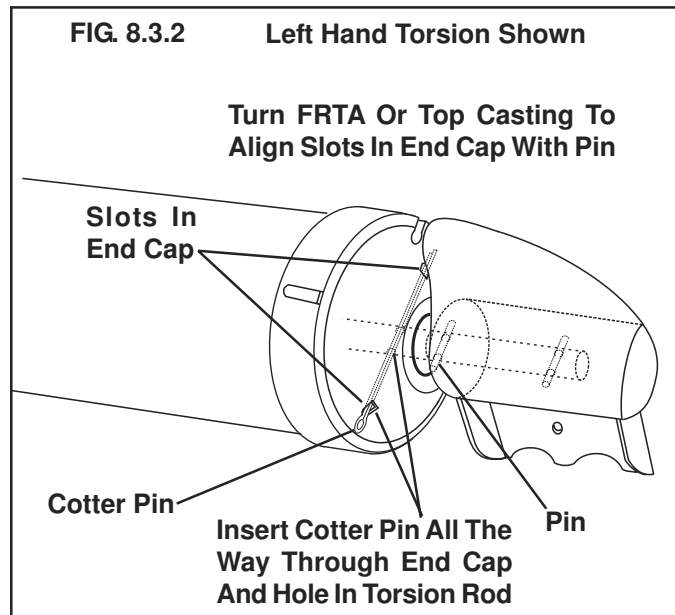

**Note:** Do step 8.3.4 if FRTA is installed on coach. If not installed on coach proceed to step 8.3.5.

- 8.3.4 Insert a wood block, between front and back channel to space the FRTA 2 - 3 inches from the coach. Push arm assembly closed. Wrap a nylon wire tie around arm to keep it from extending.

- 8.3.5 Remove Hex Head 1/4"-20 x 1/2" screw that attaches arm assembly to top casting. Lift casting out of arm assembly.
- 8.3.6 Clamp a Vice-Grip® firmly to the top casting. See FIG. 8.3.6.

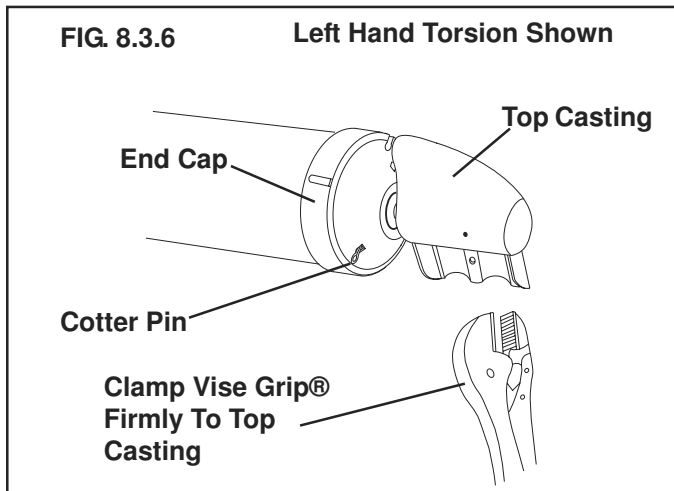

- 8.3.7 Keep a tight hold onto the Vice Grip® while the cotter pin is pulled out of the end cap.
- 8.3.8 Slowly unwind the spring tension, do not allow rapid spin off.
- 8.3.9 Use the electric drill with a 3/16" drill to remove the 3 pop rivets that secure the end cap to the roller tube. Pull the torsion out of the tube and remove any burrs or rivet bodies.

**Note:** If the awning is installed on a coach, complete the following steps on a step ladder with the FRTA extended two turns from the awning rail.

#### 8.4 Right Hand Drive Assembly Removal

- 8.4.1 When the removal of the Right Hand Drive Assembly is necessary, the left hand must be pinned, or the FRTA will unroll and the spring tension will be lost. See Section 8.3

**Note:** Do step 8.4.2 if FRTA is installed on coach. If not installed on coach proceed to step 8.4.3.

- 8.4.2 Insert a wood block, between front and back channel to space the FRTA 2 - 3 inches from the coach. Push arm assembly closed. Wrap a nylon wire tie around arm to keep it from extending.
- 8.4.3 Remove Hex Head 1/4-20 x 1/2" screw that attaches arm assembly to top casting. Remove arm assembly.
- 8.4.4 Use the electric drill with a 3/16" drill to remove the 3 pop rivets that secure the end cap to the roller tube. Pull the drive assembly out of the tube and remove any burrs or rivet bodies.

#### 8.5 Fabric Removal From Roller Tube

- 8.5.1 Remove awning from coach. See Section 8.2.

- 8.5.2 Remove both torsions. See Sections 8.3 and 8.4 for drive assembly removal.
- 8.5.3 Roll the awning completely out on a clean smooth surface.
- 8.5.4 With the awning laying flat, slide the roller tube out from fabric.

**Note:** Use needle nose pliers to remove the poly rope from the groove(s) of the roller tube before removing fabric.

#### 8.6 WEATHERSHIELD ASSEMBLY REMOVAL AND REPLACEMENT

- 8.6.1 Remove the two screws (one on each side) that lock slat "A" to first slat "B". See FIG. 8.6.1 & 8.6.3.

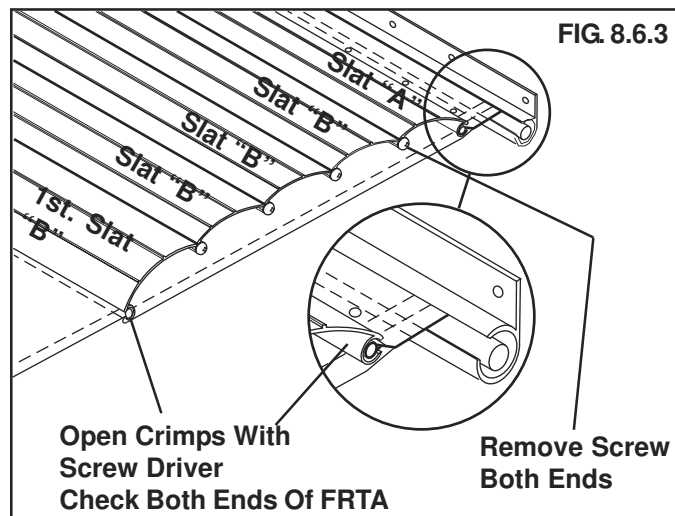
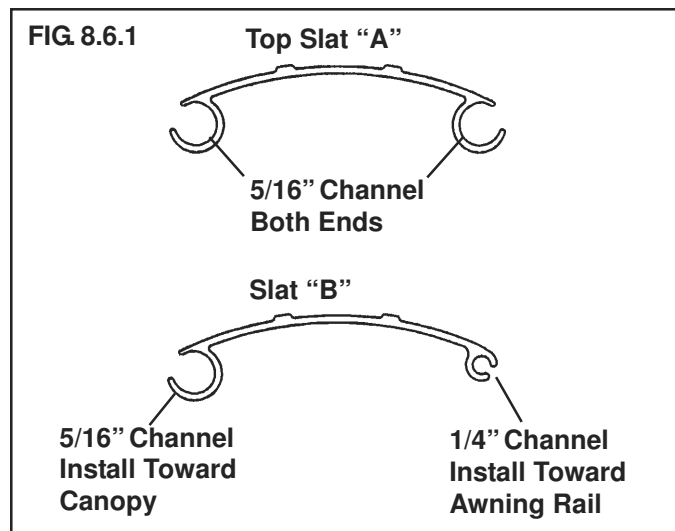

- 8.6.2 Use "O" ring pliers to spread open the crimp in the slats Slide the top slat "A" off slat "B" (toward canopy) to allow the slat assembly to slide off fabric. Keep for re-install in Step 8.6.5 (unless new slat assembly is being installed). If new fabric is being installed, lay new fabric over old one. Check for correct size and color.
- 8.6.3 The new replacement weathershield/fabric will be installed as shown in FIG. 8.6.3. Place connected slat assembly on top of fabric.

**Note:** Make sure the 1/4" groove on all "B" slats are toward awning rail. If new weathershield assembly is being installed, it is shipped with 6 slats. Remove the first slat "B", it is not needed.

- 8.6.4 Use a small file and round ends of the groove in the 5/16" end of first slat "B" and "A". See FIG. 8.6.1 & 8.6.3.
- 8.6.5 Slide first slat "B" of the connected weathershield assembly (if slat "A" was removed in Step 8.6.2, it should be replaced) onto the poly rope in fabric located approximately 12" from awning rail end; and, at the same time, slide slat "A" onto poly rope located 1" from awning rail. See FIG. 8.6.1 & 8.6.3. Slide the weathershield onto both ropes at the same rate.
- 8.6.6 Crimp both channels of the weathershield about 3" from end of slats onto poly rope to secure the weathershield assembly to the fabric. It is only necessary to crimp weathershield on one end of the FRTA. See FIG. 8.6.3.

**8.7 Re-Install Fabric On Roller Tube**

8.7.1 Unfold the new fabric and lay it on top of the existing fabric in the **exact same position**. Be sure the new fabric is the correct size and color. If roller tube is being replaced, make sure it is the correct length and position it with the notch located as shown in FIG. 8.7.1.

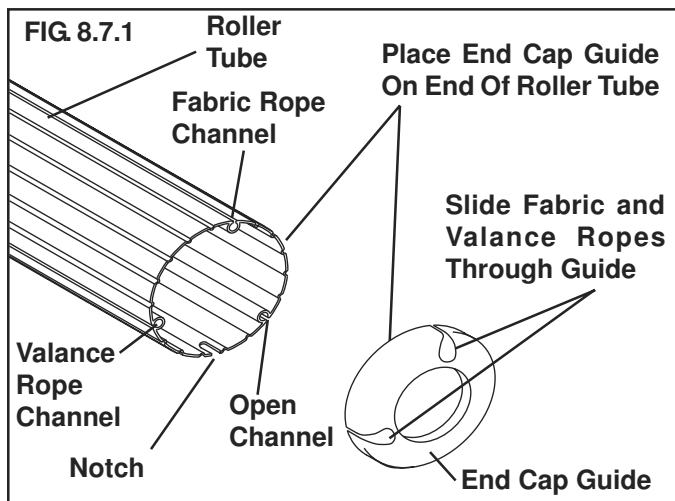

8.7.2 Dometic requires the use of the end cap guide to prevent damage to the fabric, when replacing the fabric/roller tube. Place the end cap guide (supplied with the replacement fabric/roller tube) on the end of the roller tube. The locating tab on the end cap guide is placed in the open (unused) channel of the roller tube. See FIG. 8.7.1.

**Note:** When changing the fabric, it is vital that the same groove(s) be used. This eliminates the need to drill any holes. On a new roller tube, the fabric rope is placed in the channel with the notch in its' edge (opposite the notch in the roller tube). See FIG. 8.7.1.

- 8.7.3 Guide the roller tube over the poly rope(s) of the fabric. Be careful not to damage the roller tube or the fabric.
- 8.7.4 Center the fabric on the roller tube and hand-roll the entire assembly in the same direction as the original fabric.
- 8.7.5 See Section 8.6 for weathershield replacement Steps 8.6.3 to 8.6.6. and Section 8.8, Replacing torsion assemblies.

**8.8 Torsion Assembly Replacement**

- 8.8.1 The poly ropes must be properly trimmed and secured to the roller tube; as it can interfere with the torsion and allow shifting of the fabric.
- 8.8.2 Use pliers to pull the fabric rope toward the center of the roller tube and push it back to lock it in the notch on the edge of the channel. Cut fabric rope 1" below channel. See FIG. 8.8.2.

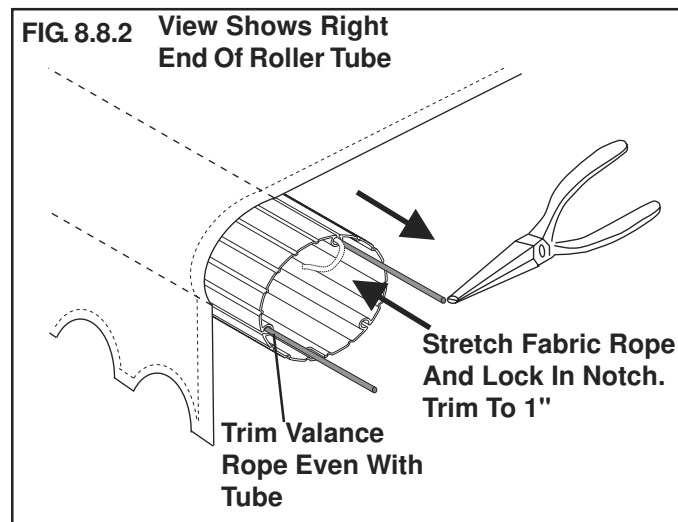

- 8.8.3 Trim valance rope even with the edge of roller tube. See FIG. 8.8.2.
- 8.8.4 Install left hand torsion
  - a. Slide left hand torsion assembly into left end of roller tube. Turn end cap till locating tabs are in place in the notch on the roller tube. This should align the open channel with the slot in the end cap.
  - b. Secure the end cap to the roller tube using three (3/6" x 3/8") pop rivets. See Section 8.9; winding left hand torsion.

- 8.8.5 Install right hand drive torsion
- New right hand drive torsions are shipped with the top casting and the stabilizer positioned for installation. If the torsion has been pre-installed it must be aligned before it is put into the FRTA.
  - Apply DC power directly to the drive assembly with the emergency harness or the control box. Allow the stabilizer to turn until one of the stabilizer slots is centered on the round slot in the motor casting. See FIG. 8.8.5.

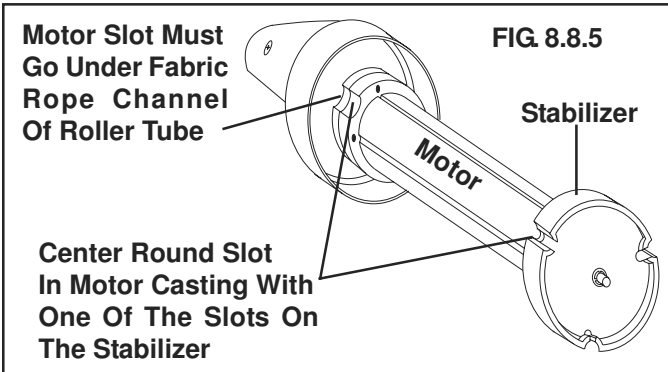

- When motor drive assembly is properly aligned as indicated in step 8.8.5b, it is placed in the roller tube with the motor slot positioned under the channel with the fabric rope. See FIG. 8.8.2.
- Turn the end cap on the motor drive torsion until the rivet hole match the holes in the roller tube. Install the three 3/16" x 3/8" pop rivets to secure the torsion to the roller tube.

**Note:** FRTA's installed on the coach will require the motor drive torsion assembly to be operated till the top casting will slip easily into the arm assembly. This will align the top casting of the motor drive to the left hand top castings. The left and right arms must be parallel to each other.

## 8.9 Left Hand Torsion Assembly Winding

### **⚠ WARNING**

**Use extreme care. Springs under tension are dangerous. If not controlled they will unwind quickly. Keep hands and clothing clear of top casting, as personal injury may result.**

**NOTE:** If the awning is installed on a coach, complete the following steps on a step ladder with the FRTA extended two turns from the awning rail.

### **⚠ WARNING**

**Severe injury can result from the rapid spin-of of the top casting. NEVER use bare hands to handle a top casting under spring tension.**

- Clamp the Vise Grip® tightly to the top casting on the left hand torsion assembly. See FIG. 8.9.2.
- Start with the Vise Grip® in the 6 o'clock position. Keep a firm hold on the Vise Grip®. Slowly wind in the direction of the arrow **9 complete turns**. See FIG. 8.9.2.

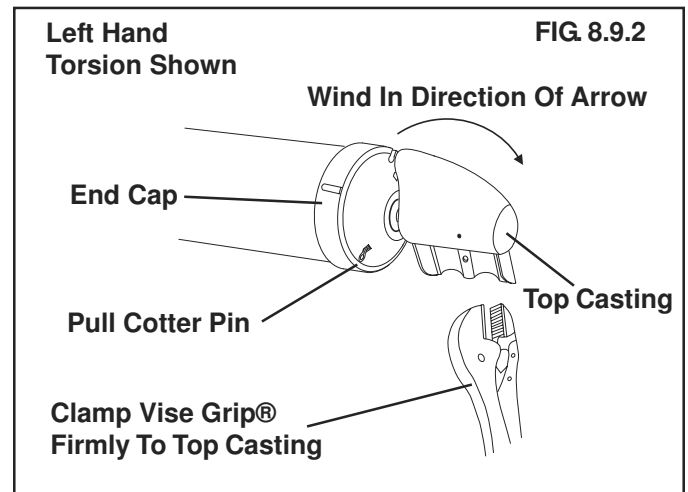

**Note:** If Awning is fully extended; wind the spring tension a total of **17 turns**.

- Turn top casting or FRTA until the pin is parallel with the two slots in the end cap. See FIG. 8.9.3. Insert a 7/64" x 2-3/4" cotter pin through the end cap and torsion rod. Put a piece of tape over the head of the cotter pin to prevent it from dropping out. See FIG. 8.9.3.

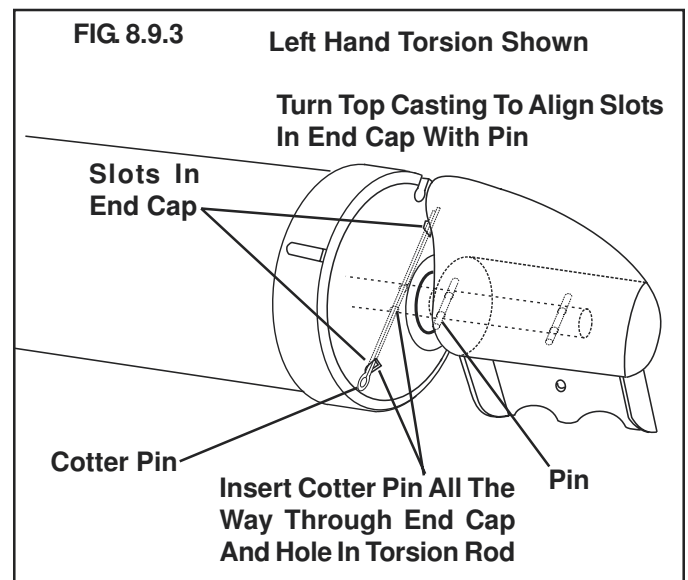

8.9.4 Remove Vise Grip® from top casting and insert into arm assembly. Replace Hex Head 1/4"-20 x 1/2" screw and tighten.

**Note:** If awning is not installed on coach. Install per the WeatherPro installation instructions.

8.9.5 Remove 2-3/4" cotter pin and check operation of the awning.

## Section 9 Wiring Diagram

### 9.1 Wiring Diagram

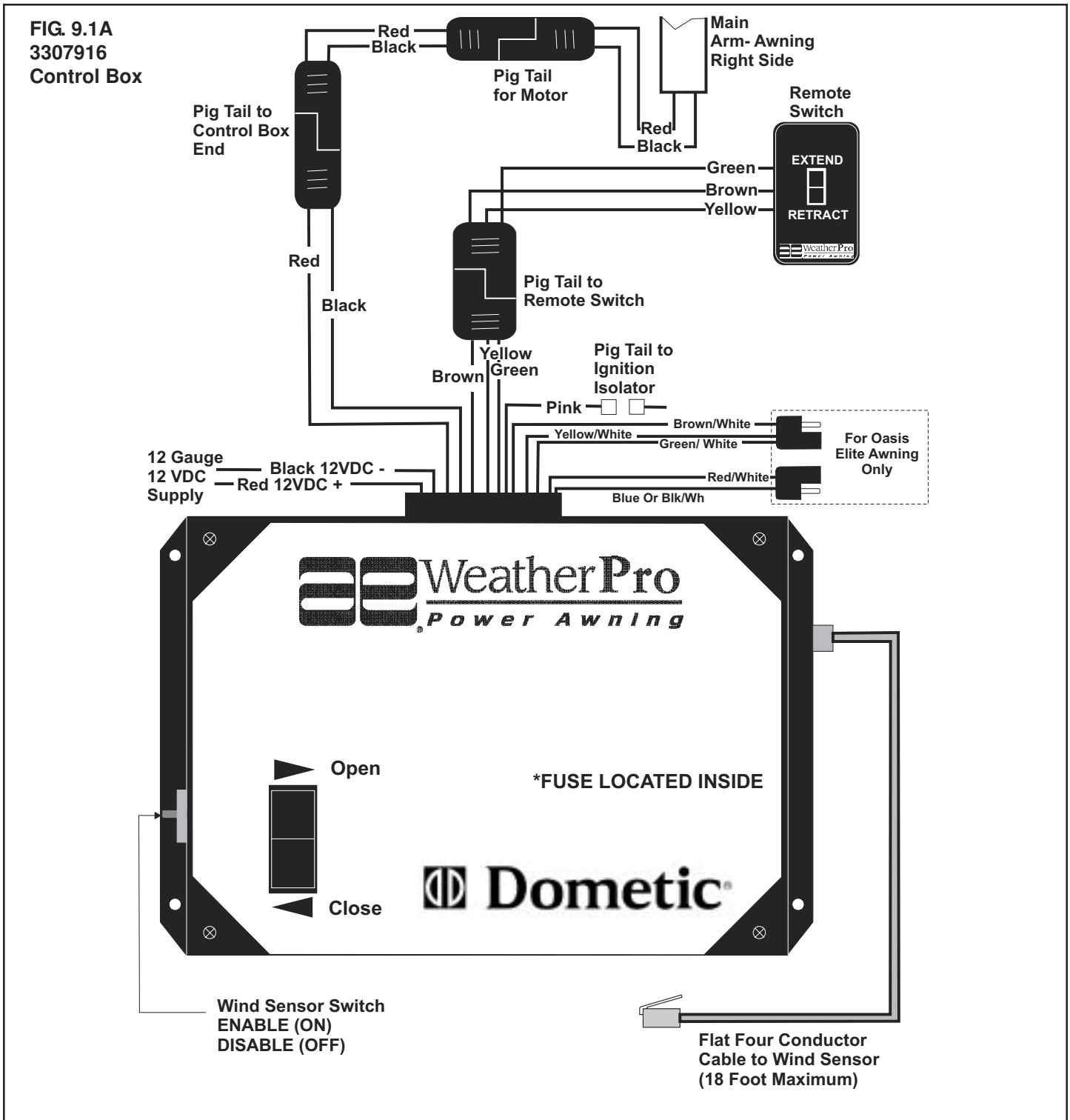

**FIG. 9.1B**  
**3307930 &**  
**3309114**  
**Control Box**

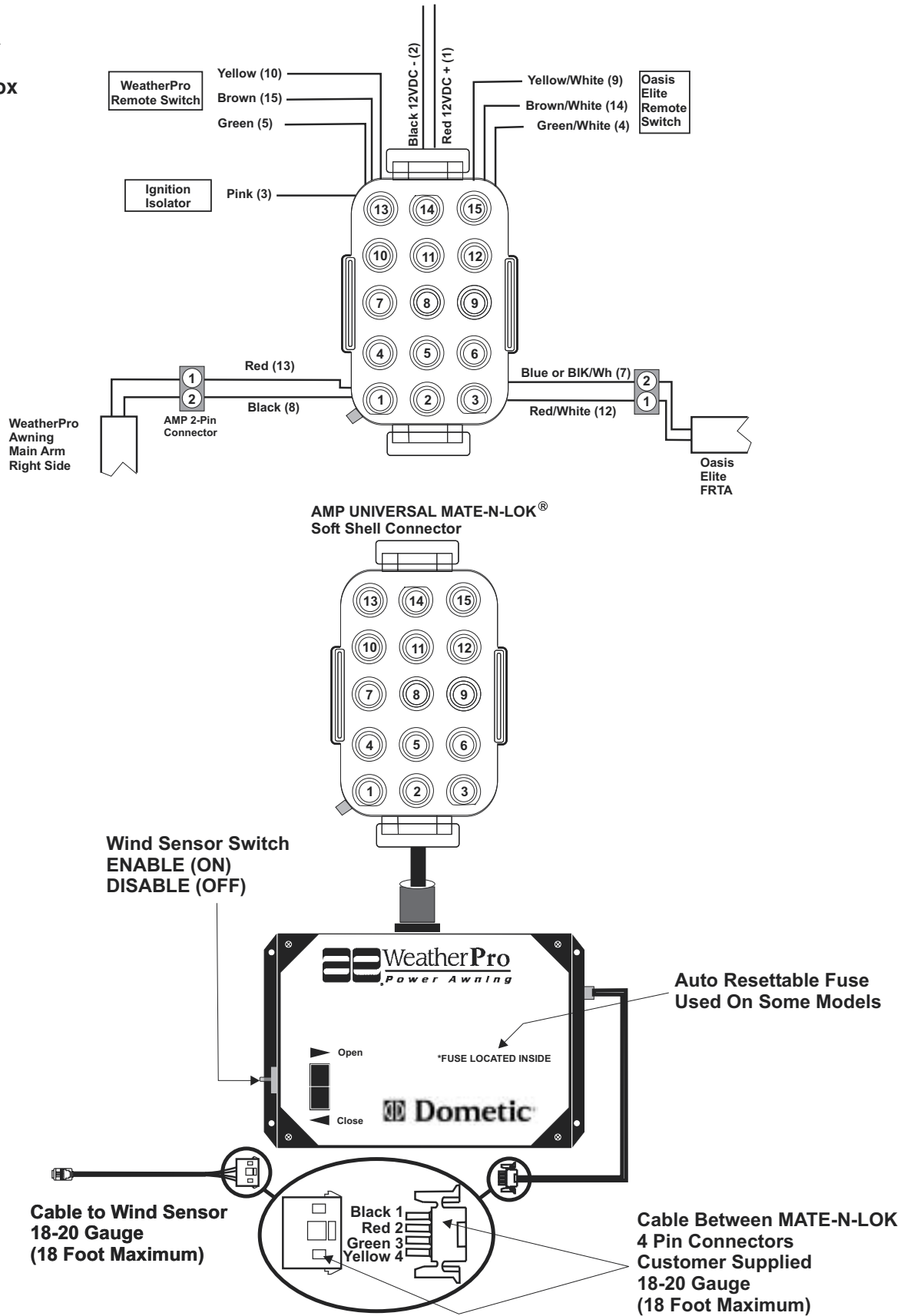



Manual provided courtesy  
Bryant RV Services  
[www.byantrv.com](http://www.byantrv.com)

All manuals are believed to be released for distribution, and/or in the public domain.

Service manuals provided with the understanding that persons using them are well versed in proper safety practices, and are familiar with basic safety procedures, including, but not limited to safety procedures dealing with 120 volt electricity, high amperage 12 volt circuits an LPG (propane) systems.

If in doubt, consult a professional (better safe than sorry).