

hydro flame™ Furnaces

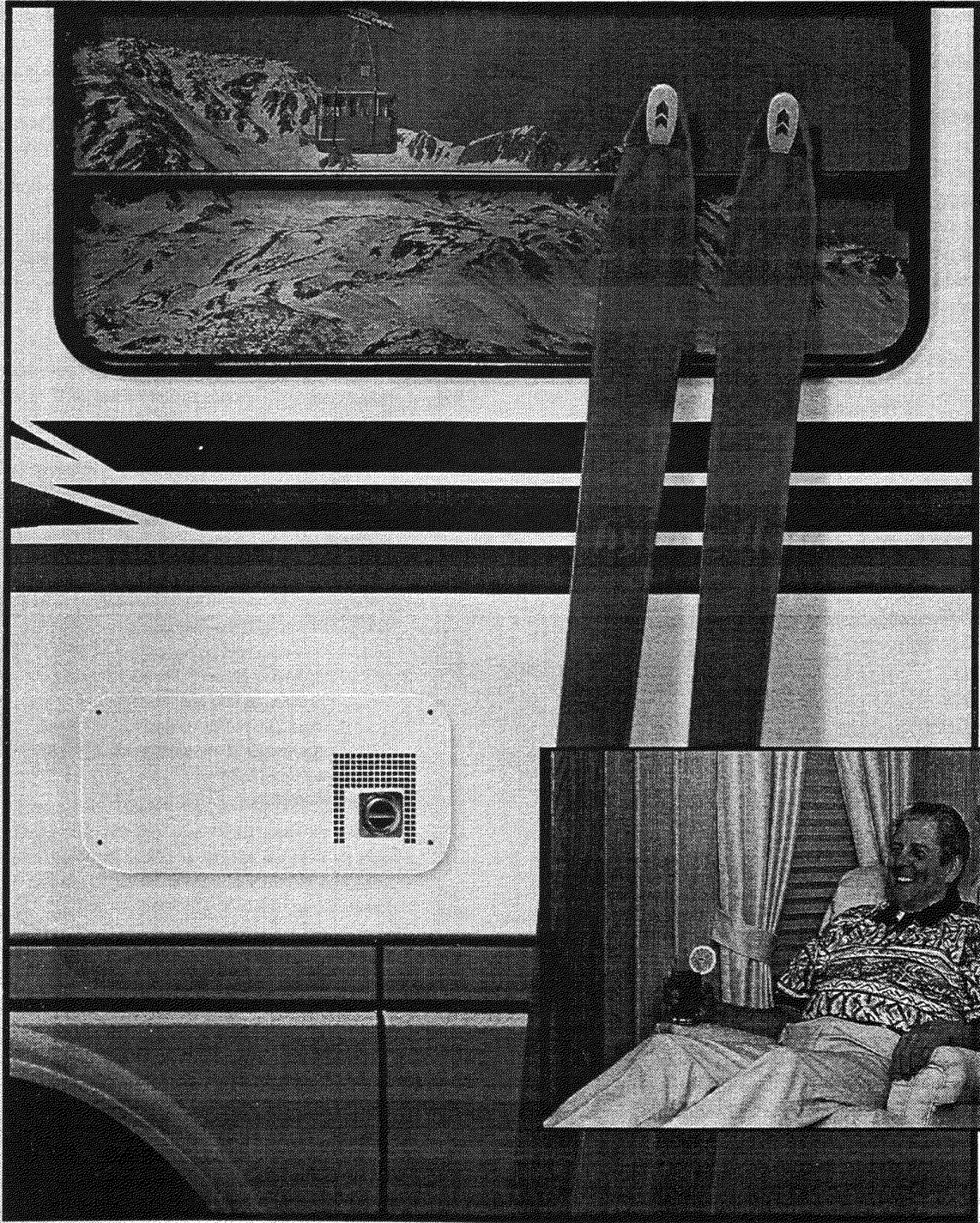

hydro flame™ Furnaces

Excalibur 8900 III Series

The Excalibur 8900 III series furnaces have mass appeal for manufacturers, service technicians, and owners alike. The compact size, especially its low profile requiring only 9 1/8" (232mm) of vertical space, provides greater flexibility in furnace location.

This results in supplying valuable storage space for consumers, greater floor plan flexibility and ease of providing optimum furnace/ducting location. A "cooling booster" ventilator option is also available.

Excalibur 8500 III Series

The Excalibur 8500 III series incorporates a new blower fan design with the new polycarbonate blower wheel combined to increase the flow of heated air. This is enhanced with the longer life motor now included in the 8531-III and 8535-III. Additionally, this increased air flow is delivered without sacrificing the minimal electrical consumption. A "cooling booster" ventilator option is also available.

Everest Star 7900 II Series

The dependable *hydro flame*™ Everest Star II series builds on the 14-year success story of its predecessor with improvements such as: an electric shut-off on the gas valve, the new blower assembly that increases air delivery by 60%, and an electronic ignition (no standing pilot).

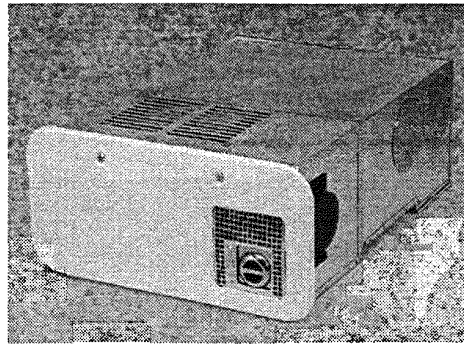

Excalibur 8900 III series

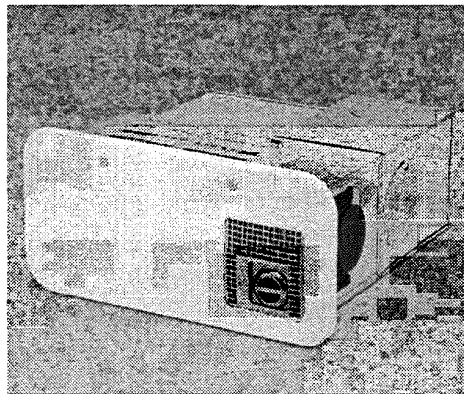

Excalibur 8500 III series

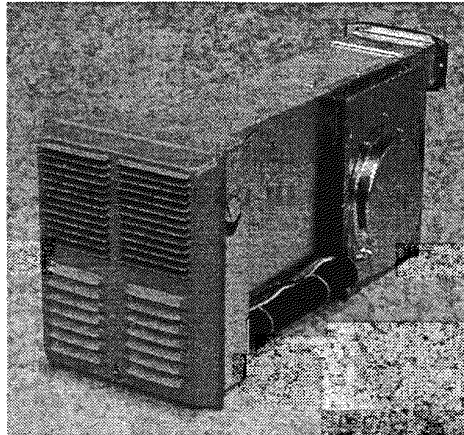

Everest Star II 7900 series

Multiple duct outlet—The 8900 series offers the standardization of one compact framing dimension, which allows you the option of installing either a 35,000 or 40,000 BTU furnace. The 8900 series also offers six different side duct outlets and a bottom discharge outlet providing you with even greater installation flexibility and the freedom to design more efficient ducting systems.

Unique vent design—The 8900 and 8500 series furnaces incorporate a unique outside vent design integral with the access door eliminating the need for a variety of vent kits.

Ease of Installation—The compact size, low profile, lightweight construction and vertical installation option enhance the space utilization possibilities and furnace placement flexibility for 8500 furnaces. A flexible adapter kit makes bottom discharge installation easy for both new and replacement applications.

Serviceability—Because of the superior design and the Exterior Access Door of the 8900 and 8500 furnaces, all controls and crucial components are easily accessible from outside of the vehicle eliminating the need to remove the furnace. These features include the external wiring connector and the external circuit breaker. In addition, unlike competitive units, there is no carbon buildup maintenance required.

Lightweight—Weighing in at just 23 pounds (10.4kg) and using only 1.10 ft³ (31.1l) of space, the *hydro flame*™ Everest Star II can deliver 12,000, 16,000 and 18,000 BTU's per hour of input heat. The compactness of the furnace optimizes space utilization and furnace placement flexibility.

Flexibility—*hydro flame*™ furnaces are known for their flexibility and the new Everest Star II is no exception. It offers three different vent kits for cabinet depths ranging from 20 1/2" (524mm) up to 31 1/8" (813mm). It can be configured for front discharge only, discharge from both side ducts, or a combination of front and side ducts.

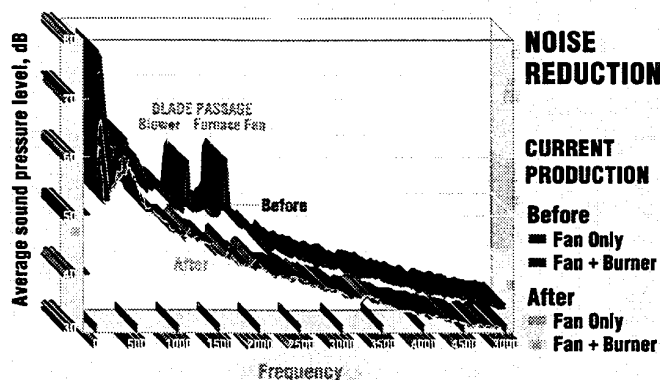

The New Excalibur 8500 "Quiet" Furnace incorporates several components redesigned to significantly reduce the sound output of the furnace

Excalibur 8900 III series Selection Guide

Model	Input BTU/hr	Gas Type		Electronic Ignition	Air Discharge		Electrical		Unit Weight		Shipping Weight	
		LP	NAT		Side	Bottom	D.C.	A.C.	lbs	kg	lbs	kg
R935DCLP	35,000	●		●	●	●	12		38	17.2	45	20.4
DCLP	40,000	●		●	●	●	12		38	17.2	45	20.4
95ACL	35,000	●	●	●	●	●		120	38	17.2	45	20.4
8940ACL	40,000	●	●	●	●	●		120	38	17.2	45	20.4

Minimum Required Clearance to Floorboards, Walls & Similar Combustible Building Materials

Top & Sides = 1/2' (12.7mm) 0" to spacers
 Bottom = 3/16" (4.76mm) 0" to spacers
 Side = 1" (25.4mm) 0" to spacers
 Rear = 1/2' (12.7mm) 0" to spacers
 Side Ducts = 1/4" (6.35mm) within 3" (914.4mm) of furnace, except that UL listed wirebound vinyl vinyl air ducts may have 0" clearance.

Excalibur 8500 III series Selection Guide

Model	Input BTU/hr	Gas Type		Electronic Ignition	Electrical D.C.	Amp Draw	Unit Weight		Shipping Weight	
		LP	NAT				lbs	kg	lbs	kg
8516-III	16,000	●		●	12 volts	4.4	28	12.7	30	13.6
8520-III	20,000	●		●	12 volts	4.4	28	12.7	30	13.6
8525-III	25,000	●		●	12 volts	5.5	30	13.6	32	14.5
8531-III	31,000	●		●	12 volts	8.2	30	13.6	32	14.5
8535-III	35,000	●		●	12 volts	8.2	30	13.6	32	14.5

Minimum Required Clearance to Floorboards, Walls & Similar Combustible Building Materials

Top & Sides = 1/2' (12.7mm)
 Rear = 1" (25.4mm)
 Bottom = 3/16" (4.76mm)
 Ducting within 3" of furnace = 1/2' (12.7mm)

(UL listed wire-bound vinyl ducts require 0" clearance)

Everest Star 7900 II series Selection Guide

Model	Input BTU/hr	Gas Type		Electronic Ignition	Electrical D.C.	Amp Draw	Unit Weight		Shipping Weight	
		LP	NAT				lbs	kg	lbs	kg
8012-II	12,000	●		●	12 volts	1.8	23	10.4	25	11.3
7912-II	12,000	●		●	12 volts	3.4	23	10.4	25	11.3
7916-II	16,000	●		●	12 volts	3.4	23	10.4	25	11.3
7920-II	18,000	●		●	12 volts	3.4	23	10.4	25	11.3

Minimum Required Clearance to Floorboards, Walls & Similar Combustible Building Materials

Top & Sides = 0" to casing spacers (screw heads)
 Rear = 0"
 Bottom = 0" to casing spacers (screw heads)
 Extension Box = 0"
 Ducting = 1/4" (6.35mm) from ducting within 3' (914.4mm) of furnace unless using UL listed wire-bound vinyl ducts which require 0" clearance.

Installation Option

The Everest Star II furnace installation offers great flexibility in cabinet depths, ranging from 20 1/2" to 31 1/8".

This range is accomplished through the selection of one of three possible exhaust vents for the furnace.

Ducting Configurations for the 8012-II

Ducting Configurations for the 79-II Series

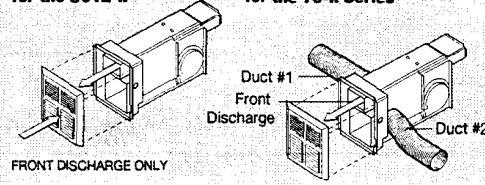

Installation Option	Vent Length Measurement				Cabinet Depth			
	Minimum		Maximum		Minimum		Maximum	
	in	mm	in	mm	in	mm	in	mm
A	0	0	3 5/8	92	20 1/2	521	24	610
B	3 5/8	92	7 1/8	181	24	610	27 5/8	702
C	7 1/8	181	10 5/8	270	27 5/8	702	31 1/8	791

Furnace Size Specifications—for all furnaces

Model	Furnace Size		Cut Out Size		Vent Cut Out Size	
	in	mm	in	mm	in	mm
8900						
Width	16 1/2	419	19 1/2	495	—	—
Height	9 1/8	232	9 7/8	251	—	—
Length	23 1/2	597	—	—	—	—
Return Air	80 in ²		516cm ²		—	
8500						
Width	16 1/2	419	17	432	—	—
Height	7 3/8	187	7 1/2	190.5	—	—
Length	18	457	—	—	—	—
Return Air	65 in ²		419cm ²		—	
7900						
Width	8 3/8	213	8 3/8	213	4 7/8	124
Height	11 3/8	289	11 1/4	286	2 1/2	63
Length	20 1/2	524	—	—	—	—
Return Air	35 in ²		226cm ²		—	

How to Order

89 SERIES

Model 89 35 DC LP 6 V
 BTU/Hr Rate
 35 = 35,000
 40 = 40,000
 Voltage
 DC = 12V
 AC = 120V
 Type Gas
 LP = Propane
 LC = LP/Nat set for LP
 Gas Connection Size
 6 - 3/8" Flare
 8 - 1/2" Flare
 Ventilator Control option

85 SERIES

Model 85 25III DC LP 6 SB BP w/o Therm
 BTU/Hr Rate
 16-III = 16,000
 20-III = 20,000
 25-III = 25,000
 31-III = 31,000
 35-III = 35,000
 Voltage DC
 Type Gas
 LP = Propane
 Gas Connection Size
 6 - 3/8" Flare
 Options
 SB = Side/Bottom
 V = Ventilator
 SB FIP = SB w/ field plug
 Packing
 SP = Single Pack
 BP = Bulk Pack (layers of 4)
 Thermostat
 = with thermostat
 w/o Therm = without thermostat

Accessories

hydro flame™—A newly designed access cover in standard colors, with a recess pan option for both 8500 and 8900 models, thermostats and a ventilator control designed for hydro flame furnaces are also available. For ordering information, contact your local Atwood representative.

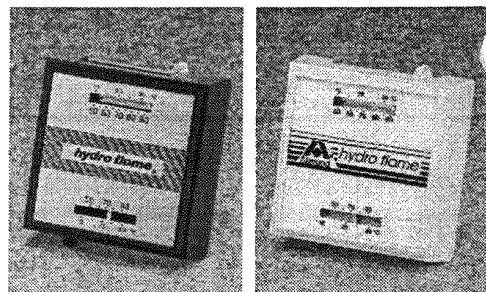
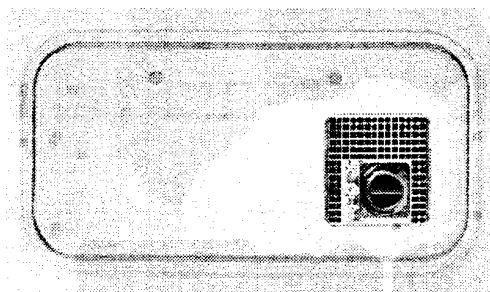

Access covers, shown here with the recess pan option, are available in standard or economy style doors.

Thermostats and ventilator controls are also available.

Product Literature

Atwood Mobile Products offers a wide range of products for many markets, including but not limited to, the RV, Industrial, Agricultural and Marine industries. Product literature is available by calling 815-877-5700 or asking your regional salesperson. Brochures are available for:

Atwood Water Heaters

Wedgewood® Ranges

ProTechTor® Gas Detectors

Chassis Components for Towable RVs

ProTow'd™ Chassis Components

Available soon:

Marine products

Seating Components

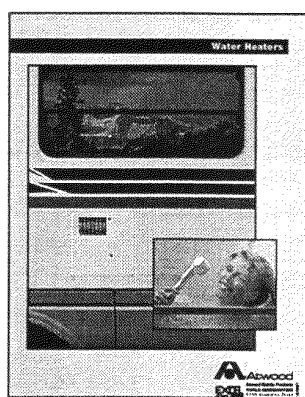

Water Heaters

- RV
- Marine

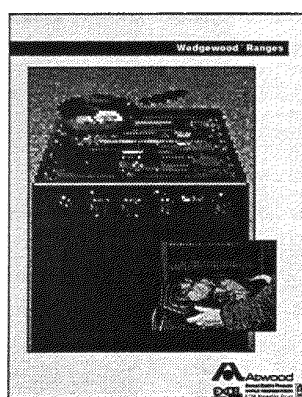

Wedgewood™ Ranges

- RV

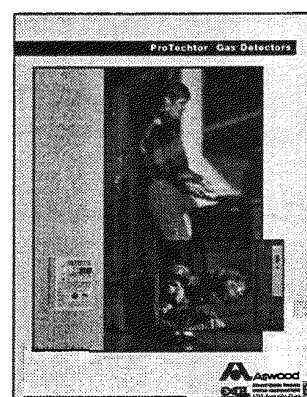

ProTechTor™ Gas Detectors

- RV

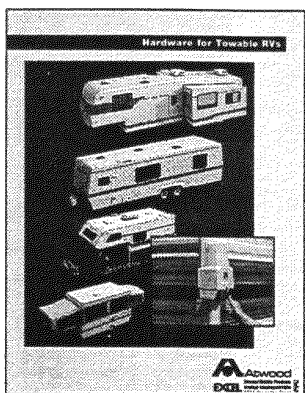

Chassis Components for Towable RVs

- Pickup Campers
- Travel Trailers
- Tent Campers
- 5th Wheels or trailers



ProTow'd™ Chassis Components

- Agricultural
- Commercial
- Industrial

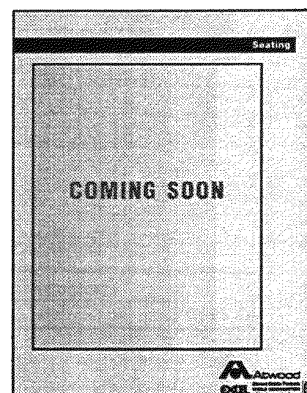

Seating

Atwood

EXCEL
AN EXCEL INDUSTRY

Atwood Mobile Products
WORLD HEADQUARTERS
4750 Hiawatha Drive
Rockford, IL 61103-1298



PHONE: 815-877-5700 FAX: 815-877-7469

79 / 80 Series Model Identification

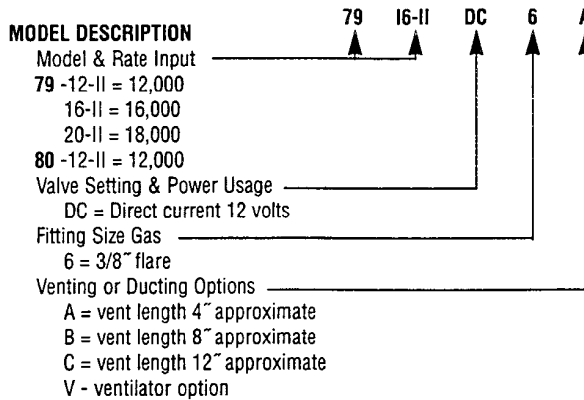

Applications - This unit is typically installed in tent campers and truck campers due to its small size and lower BTU capacities. It is sometimes used in larger trailers or motor homes for smaller zone heating.

Heat Outlets - This furnace is usually set up as a front discharge unit. However, it does have a 4" duct outlet on either side of its casing for soft ducting to remote outlets. To determine the most efficient ducting configuration, refer to **Minimum Ducting Configuration**.

Directional Air Box Insert - If you need to direct heat to the front or rear of a camper and you cannot use soft ducting and registers, an optional diverter plate with 55 degree louvers can be added to the front exhaust box.

Serviceability - Practically all of the components of this furnace are accessible by removing the front grille. Therefore, the furnace does not need to be removed for most repairs. The only components that are not accessible without removing the furnace are the blower motor, sail switch and blower and combustion wheels.

Power Consumption - The 79 series furnace draws only 3.4 amps. However, there is an 8012 series furnace that has a heating capacity of 12,000 BTU's and only draws 1.8 amps. This furnace is ideal for someone who does a lot of dry camping.

MINIMUM DUCTING CONFIGURATION

7912-II 7916-II 7920-II - SIDE DISCHARGE UNITS -
Provides the most air flow and heat to remote heat outlets. The duct runs need to be as short and straight as possible for optimal heating.

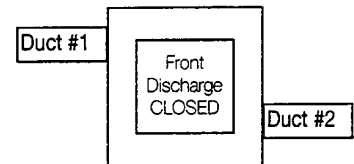

7912-II 7916-II 7920-II - SIDE DISCHARGE UNITS - with front discharge-
The majority of the heat discharges out the front. A minimal amount of heat will pass through the side ducts. These duct runs need to be as short as possible. An optional air diverter with 55° angle vanes can be added to front discharge opening to direct heat for or aft in the trailer.

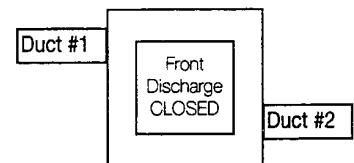

8012-II 7912-II 7916-II 7920-II - FRONT DISCHARGE UNITS - no ducts allowed on 8012-II-
The heat discharges only through the front. The optional air diverter noted above can be added to front discharge opening to direct heat for or aft in the trailer.

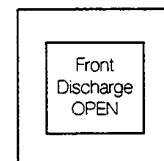

RETURN AIR REQUIREMENTS

Return air is provided through the front door grill - approximately 33 square inches (213cm²). If the furnace is installed at zero clearance, an additional 16 square inches (103cm²) of return air must be provided to the blower wheel side of the furnace.

79-II Directional Air Box Insert

An air discharge diverter is now available for all 79 series furnaces. This insert has fins that are set at a 55 degree angle. This will allow you to direct the heat fore or aft in the camper easier.

1. Remove the front grill of the furnace.

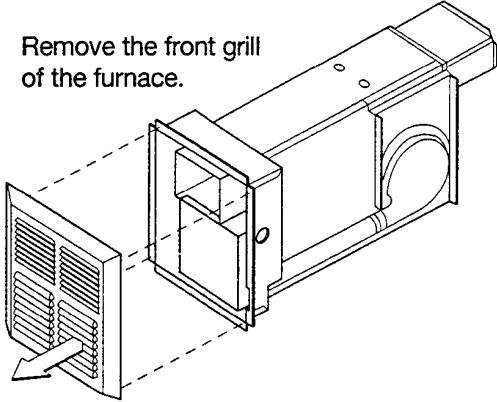

2. Follow the shutdown procedure instructions affixed to the furnace.
3. Remove the sheet metal screw that holds the DSI plate to the air box. Retain to fasten the Air Box Insert to the bottom of the air box.

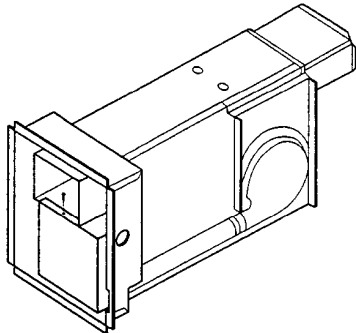

4. Install the Air Box Insert into the air box paying particular attention to the direction where you would like the warm air diverted. Make sure the two holes in the Air Box Insert line up with the existing holes in the air box.

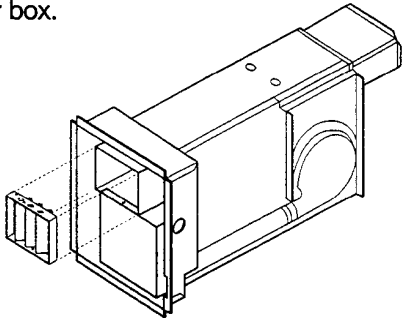

5. Fasten the Air Box Insert to the top of the air box using a 1/4" long #6 sheet metal screw. Fasten the bottom of the Air Box Insert and the DSI plate to the bottom of the air box using the screw removed in step 3.

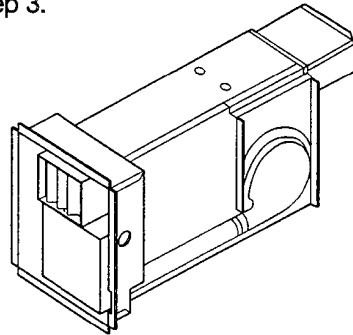

6. Follow the lighting instructions to place the furnace in operation.
7. Replace the front grill on the furnace.

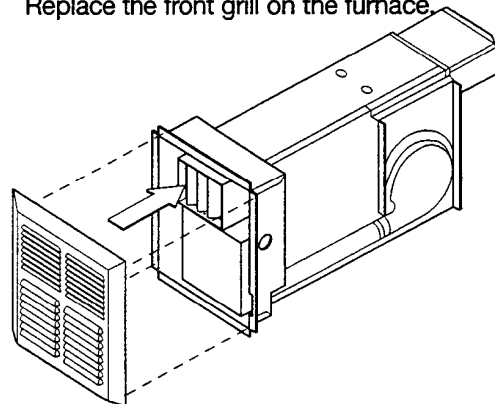

Wiring Diagram for 7900-II

LOCAL Sense Wiring

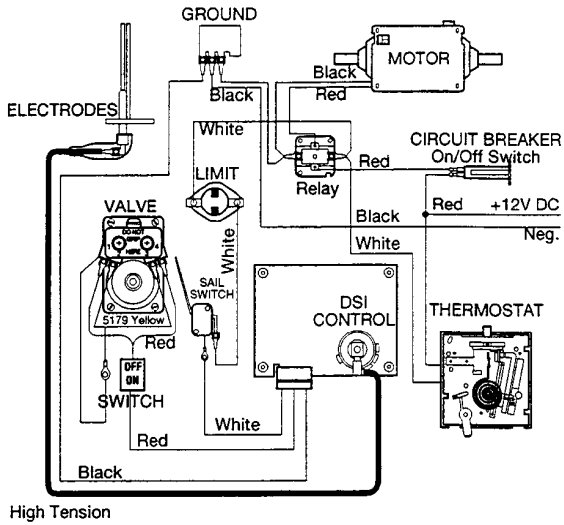

NOTE: The ON/OFF switch, located in line with the gas valve, is not used when a combination circuit breaker and ON/OFF switch is used.

IMPORTANT

If any original wire has to be replaced, it must be replaced with type 105° C or its equivalent.

REMOTE Sense Wiring

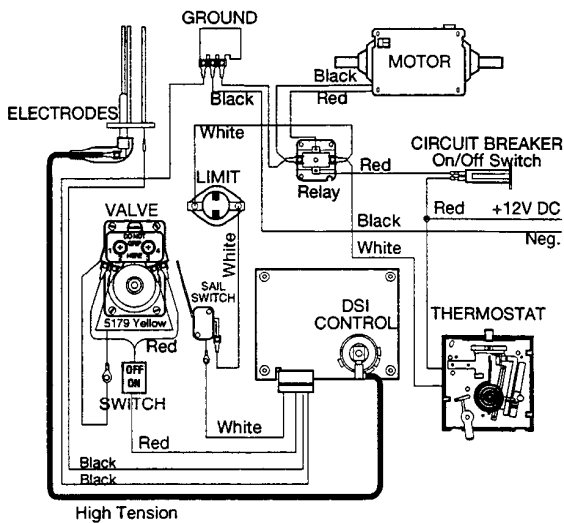

NOTE: The ON/OFF switch, located in line with the gas valve, is not used when a combination circuit breaker and ON/OFF switch is used.

85 Series Model Identification

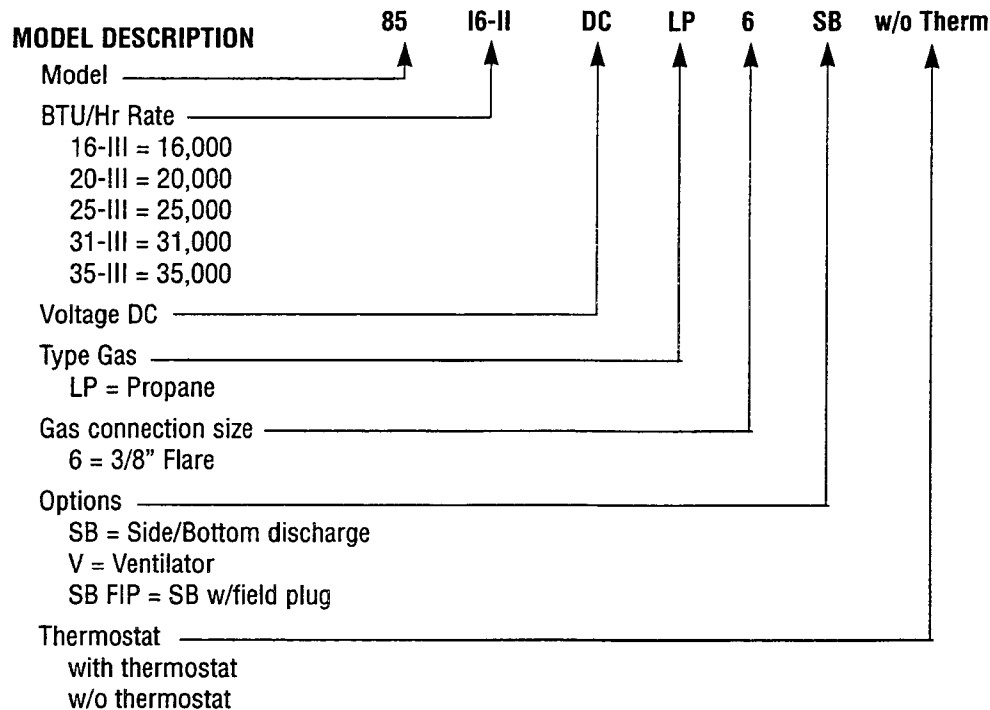

Applications - This unit is typically installed in travel trailers, 5th wheels and motor homes.

Installation - This series of furnace can be installed either vertically or horizontally. If installed vertically, the exhaust port must be located at the bottom. Extra care must also be given in sealing this type of installation as per the installation manual.

Heat Outlets - This furnace can be bottom discharged to a hard duct system, soft ducted out the back to a discharge plate into a hard duct system or completely soft ducted from a combination of the seven outlets located on both sides and back of the furnace. Refer to the installation manual for the ducting requirements of the specific model of furnace.

Serviceability - This entire furnace is serviceable without removing it from the RV. Therefore, there is no need to bench test it. All components are accessible by merely opening the access door. We strongly recommend trouble-shooting the furnace while it is installed in the RV.

Power Consumption - This furnace is designed to draw between 4.4 and 8.2 amps depending on the model of the furnace. Refer to the furnace specification decal when trouble-shooting its electrical system.

89 Series Model Identification

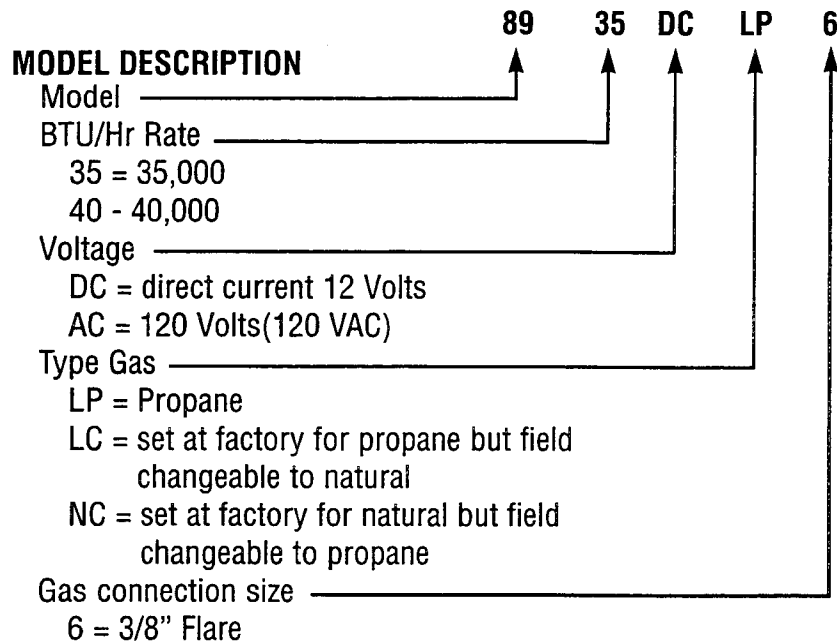

Applications - This unit is typically installed in large travel trailers, 5th wheels and motor homes and park model trailers.

Installation - This series furnace can only be installed horizontally.

Options - As the chart above indicates, this furnace can be purchased to operate on 12VDC or 120VAC with LP gas or Natural gas.

Heat Outlets - This furnace can be bottom discharged to a hard duct system, soft ducted out the back to a discharge plate into a hard duct system or completely soft ducted from a combination of the seven outlets located on both sides and back of the furnace. Refer to the installation manual for the ducting requirements of the specific model of furnace.

Serviceability - This entire furnace is serviceable without removing it from the RV. All components are accessible by merely opening the access door. We strongly recommend trouble-shooting the furnace while it is installed in the RV.

Power Consumption - The DC version of this furnace is designed to draw approximately 11.0 amps. This is important when trouble-shooting the motor of this furnace.

89 SERIES RECALL

There is currently a recall being conducted on the 8900-II series furnaces, both AC and DC versions.

- Serial Numbers:** 699173 - 840685 (All numbers begin with U.L.M-)
- RV's Affected:** Installed mostly in '93 RV's
- Problem:** Premature chamber deterioration, especially in marginal installations which may result in burn-through and/or CO emissions.
- Remedy:** Replace chamber. May replace additional parts or furnace as needed. We will pay to perform recall remedy.

Note: Chambers or furnaces to be supplied by hydro flame.

Call hydro flame prior to the repair on the following recall line 1-800-748-4454.

START	END	START	END	START	END	START	END
699173	- 699182	743608	- 743612	766006	- 766012	815030	- 815156
700287	- 700294	743892	- 743901	766469	- 766478	815961	- 815976
700445	- 700646	744722		766681	- 766685	817276	- 817424
700938	- 700976	745026		767076	- 767285	820273	- 820344
702479	- 702558	745585	- 745603	767709	- 767771	820459	- 820488
702762	- 702806	745922		768182	- 768191	820962	- 821126
703620	- 703623	746982	- 747015	769532	- 769631	823445	- 823558
703671	- 703752	747221	- 747229	770001	- 770031	824073	- 824105
703954	- 704008	747330	- 747348	770197	- 770284	824282	- 824309
704904	- 704922	749113	- 749123	770396	- 770434	825305	- 825319
705373	- 705383	749956	- 749960	770543	- 770577	825620	- 825703
705657	- 705702	750017	- 750111	773847	- 773991	826054	- 826148
706271	- 706312	750376	- 750388	774511	- 774518	829412	- 829431
706537	- 706611	750902	- 750961	775856	- 775895	829643	- 829707
706862	- 706873	751621	- 751646	776031	- 776050	829892	- 829947
707899	- 707917	751739	- 751744	777292	- 777307	830210	- 830304
708145	- 708186	752229	- 752284	777426	- 777462	832859	- 832883
708919	- 708923	752485	- 752552	777558	- 777618	832984	- 833028
709209	- 709271	752779	- 752781	777866	- 777875	833129	- 833192
709332	- 709348	753067	- 753133	778175	- 778209	833443	- 833467
710752	- 710823	754726	- 754760	778410	- 778483	838374	- 838441
710834	- 710909	754936	- 754961	778864	- 778959	838692	- 838816
711458	- 711545	755316	- 755358	780925		839330	- 839351
712758	- 712826	755464	- 755506	781653	- 781682	839851	- 839876
735516	- 733527	755623	- 755638	782096	- 782115	840580	- 840685
735650	- 735746	755725		782125	- 782212		
737343	- 737362	755805	- 755860	782831	- 782859		
738438	- 738547	756021	- 756070	782861	- 782878		
738751	- 738770	756346	- 756395	783227	- 783306		
739931	- 739975	758088		784232	- 784233		
741357	- 741400	758333	- 758360	807224	- 807256		
741507	- 741508	758461	- 758502	808036	- 808210		
741710	- 741739	758662	- 758701	809868	- 809978		
742408	- 742505	759028	- 759073	810901	- 810981		
742706	- 742754	760115	- 760147	811782	- 811902		
743100	- 743194	760488	- 760532	812611	- 812687		
743205	- 743244	760654	- 760714	813668	- 813799		
743492	- 743514	765700	- 765716	814299	- 814328		

Note: These furnaces were manufactured from March 1, 1992 to January 1, 1993.

Wiring Diagram for 8900-III

DC Wiring Diagram

Supply Leads	Furnace Wiring
(+) 12 volt DC	to (+) 12 volt DC (red wire)
(-) 12 volt D	to (-) 12 volt DC (yellow wire)
thermostat	to thermostat (blue wires)

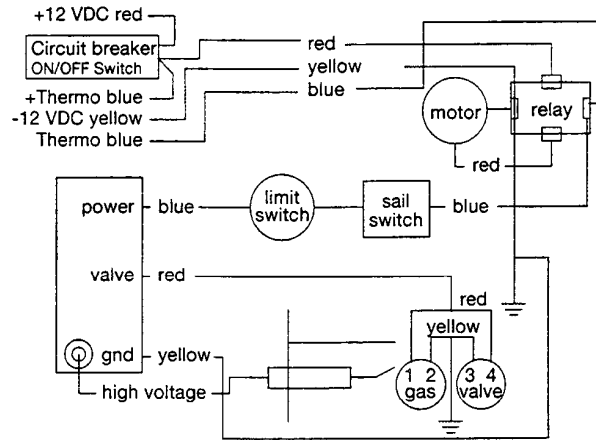

IMPORTANT: If any original wire has to be replaced, it must be replaced with type 105° C or its equivalent.

AC Wiring Diagram

Supply Leads	Furnace Wiring
120 volt AC	to 120 volt AC (black wire)
120 volt AC	to 120 volt AC (white wire)
ground	to ground (green wire)
thermostat	to thermostat (blue wires)

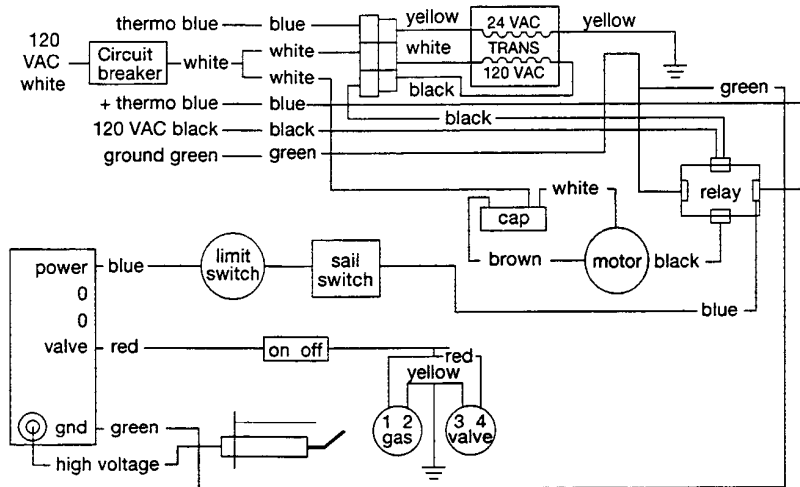

NOTE: The ON/OFF switch, located in line with the gas valve, is not used when a combination circuit breaker and ON/OFF switch is used.

Motor Upgrade Replacement Instructions DC 85-III & 89 Models Only

Installation instructions for all 85-III and 89-DC model furnaces for replacing motor with plug-in leads to motor with permanent leads. This motor is designed to give more hours of performance.

For removal and installation of motor perform the following steps:

1. Shut off power and turn off gas to the furnace.
2. Open outside door.
3. Remove 4 screws holding back cover to blower housing.
4. Remove draft shield assembly and disconnect gas line.
5. Remove 4 screws that hold burner assembly in place. (On 89 models you will need to remove the rain shield assembly before removing burner assembly.)
6. Remove both the combustion wheel and blower wheel.
7. Remove red + 12 vdc wire from relay to motor. Discard wire.
8. Remove yellow -12vdc wire from motor. Cut wire flush with blue splice on motor side of relay.
9. Remove 3 screws holding motor assembly to motor wall.
10. Attach red +12vdc wire from new motor to relay.
11. Attach black -12vdc wire from new motor ground lug above blower cover.
12. Reassemble in reverse order, starting with #9.
13. Check gas connections for leakage with a leak test solution, according to ANSI A 119.2/NFPA 501C Recreational Vehicles Standard section 2-4. 18.2.

IMPORTANT - Make sure proper motor is used for the model furnace. See chart below.

MODEL	KIT #	MOTOR #
8516-20-III	37359	37351
8525-III	47358	37352
8531-35-III	37357	37353
DC 8935-40	37357	37353

Recommended Tools and Equipment

U-Tube Manometer - This is the most accurate device for measuring gas pressure. If you use a dial-type manometer, it should be calibrated periodically with this type of manometer.

Multi-meter - This is the most effective meter capable of reading voltage, amperage and continuity. A test light cannot give you specific enough information to trouble-shoot a furnace properly.

U-TUBE MANOMETER

with 1/8" pipe nipple

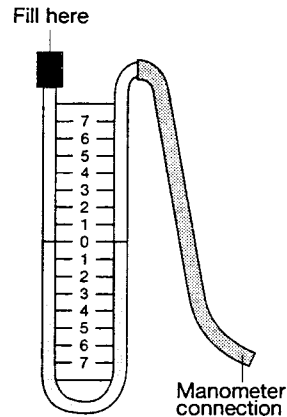

VOLT OHM METER

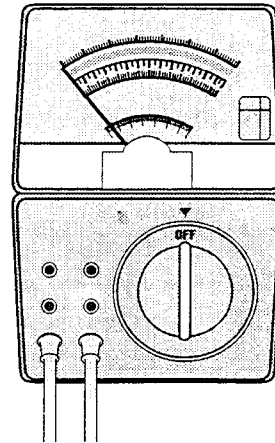

Fenwal Board Tester - This is a table top device that will test all furnace circuit boards. It will specifically test the following board functions: power, spark, lamp, sense and valve.

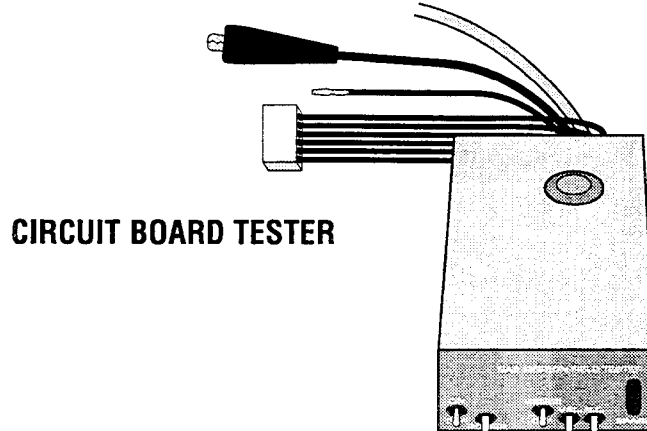

CIRCUIT BOARD TESTER

Air Speed Indicator - This hand held device will let you determine air flow out of a heat register. It will help you isolate restricted ducting.

Incline Manometer - This meter measures the static pressure of the furnace cavity. It provides an x-ray of the total heating system. It will indicate if all of the heat being produced by the furnace is being sufficiently distributed out to the heat registers.

Long-handled Allen Wrenches (1/4" and 1/8") - These two wrenches are necessary to remove the blower wheel and the combustion wheel.

Common Hand Tools - 1/4" nut drivers, open end wrenches, flat blade and Phillips screw drivers.

Leak Test Solution - A solution that bubbles when applied to gas fittings or connections showing where a gas leak is present.

Sequence of Operations - DC Models

The thermostat controls the operating circuit to the furnace by reacting to room temperature. When room temperature is below the thermostat set point, the contact closes to allow current to flow to the relay.



The circuit breaker limits amperage draw of the motor.



The relay allows current to pass to the motor by closing a switch within the relay. A heater coil within the relay actuates a bimetal disc which closes the relay circuit. This takes 17-20 seconds.



Current flows to the motor to operate the blower. One end of the motor shaft is for the circulating air wheel and the other side is for the combustion air wheel.



Circulating air blows against the sail switch and closes the contacts, completing the circuit. The sail switch is a safety device that insures air flow before ignition.



The limit switch is a safety device that protects the furnace from over heating. The contacts in the limit switch open at a given temperature setting, shutting off power to the direct spark ignition (DSI) system that controls the gas valve.



As power is applied to the DSI board, the system does the following:

1. A timing circuit allows the blower to purge the chamber (15-17 seconds)
2. The board supplies current to the gas valve and causes it to open. A manual electrical switch is provided and must be in the "ON" position for current to reach the valve.
3. As the valve opens, the board sends a high voltage spark to the electrode at the burner. The board detects the presence of a flame. If the flame is not sensed after approximately six seconds, the board will lock out (three try for ignition, one hour lockout and then three retry), shutting off power to the valve.
4. If the system does not ignite and the thermostat remains closed, the blower will remain on until the thermostat is reset manually.



When the thermostat senses the desired room air temperature, the contacts open, removing power from the ignition system and shutting off the gas valve. The blower runs until the heater in the relay cools and opens the circuit, shutting off current to the motor.

⚠ WARNING **FURNACE PRODUCES HIGH TEMPERATURE**

- Locate furnace out of traffic and away from furniture and draperies.
- Do not touch or put combustibles near appliance. Hot surface temperature may occur.
- Supervise young children in the same room as the furnace.
- Do not place clothing or flammable materials on or near the furnace.

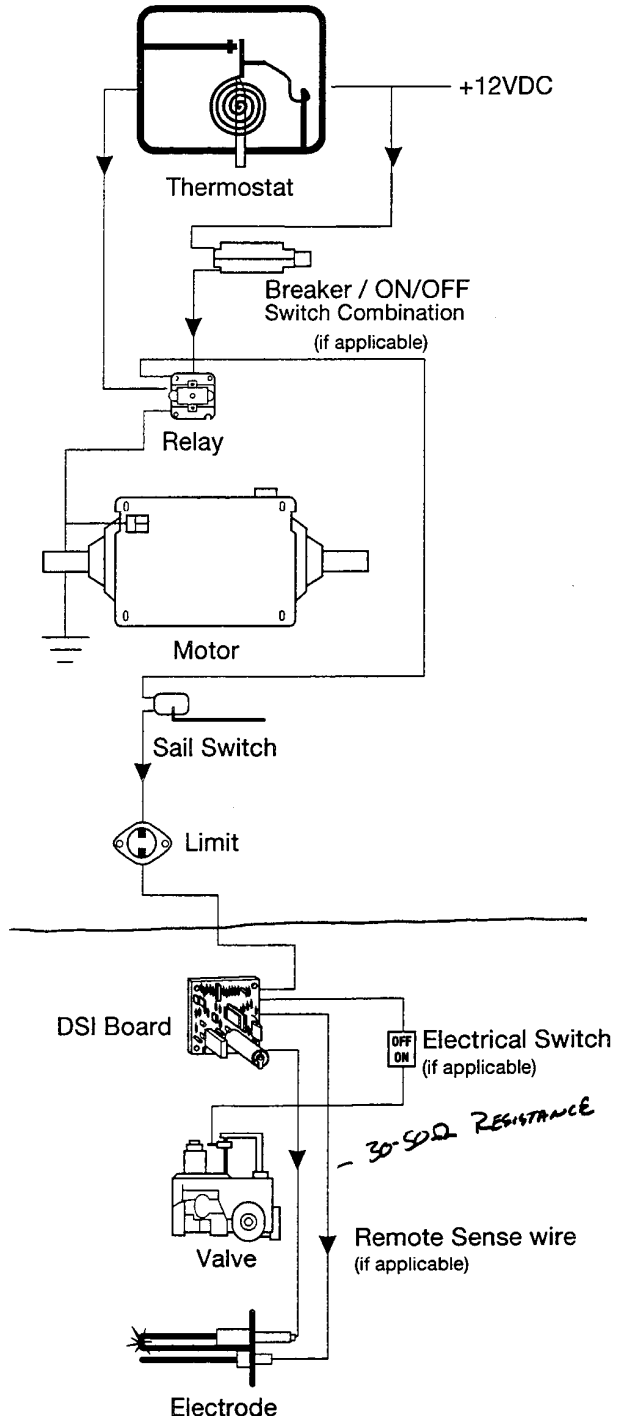

Sequence of Operations - AC Models

Operating Circuitry 24 VAC

The transformer receives 120 VAC which it converts to 24 VAC for the operating circuitry.

The thermostat controls the operating circuit to the furnace by reacting to room temperature. When room temperature is below the thermostat set point, the contacts close to allow current to flow to the relay. The relay receives 24 VAC and energizes a heater coil within the relay. This activates a bimetal disc which closes the relay circuit. This takes 17-20 seconds.

Once the relay circuit is closed, 120 VAC flows to the motor and allows the blower to run. One end of the motor is for the circulating air wheel and the other end is for the combustion air wheel.

Circulating air blows against the sail switch and closes the contacts, completing the circuit. The sail switch is a safety device that insures air flow before ignition.

The limit switch is a safety device that protects the furnace from overheating. The contacts in the limit switch open at a given temperature setting, shutting off power to the direct spark ignition/electronic ignition system that controls the gas valve.

As power is applied to the direct spark ignition circuit board, the system does the following:

1. A timing circuit allows the blower to purge the chamber (15-17 seconds).
2. The board supplies current to the gas valve and causes it to open. There is an electrical switch in line to the valve to allow power to be manually shut off to the valve. This switch must be on for the furnace to operate. (Switch may be separate or combined with circuit breaker).
3. As the valve opens, the board sends a high voltage spark to the electrode at the burner. The board detects the presence of a flame, if the flame is not sensed after seven seconds, the board will lock out, shutting off power to the valve.
4. If the system does not ignite and the thermostat remains closed, the blower will remain on until the thermostat is reset manually.

When the thermostat senses the desired room air temperature, the contacts open removing power from the ignition system and shutting off the gas valve. The blower runs until the heater in the relay cools and opens the circuit, shutting off current to the motor.

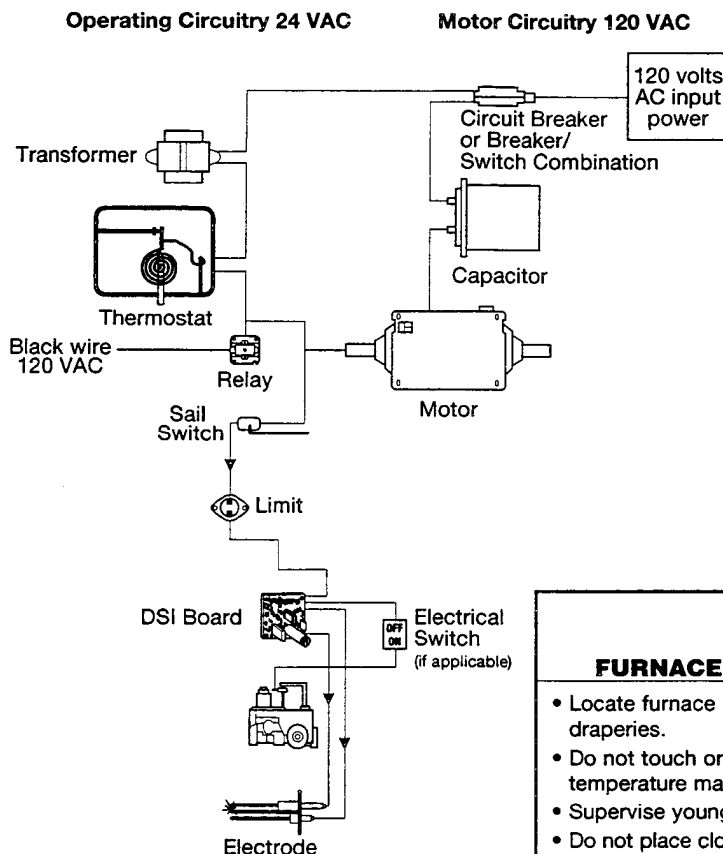

WARNING FURNACE PRODUCES HIGH TEMPERATURE

- Locate furnace out of traffic and away from furniture and draperies.
- Do not touch or put combustibles near appliance. Hot surface temperature may occur.
- Supervise young children in the same room as the furnace.
- Do not place clothing or flammable materials on or near the furnace.

Sequence of Operations Pilot Models

The thermostat controls the operating circuit to the furnace by reacting to room temperature to open and close a set of contact points which allows current to flow to the relay.



The relay receives the current and allows current to pass through to the circuit breaker by closing a switch within the relay. This is done by a heater coil within the relay which actuates a bi-metal disc closing the relay circuit.



The circuit breaker is placed in line to monitor the draw of the motor. It is an overload and safety protector for the motor.



The current then flows to the motor and allows the blower to operate. One end of the motor shaft drives the circulating air wheel and the other end of the motor shaft drives the combustion air wheel that delivers the required air to the burner for combustion.



As the circulating air wheel comes up to speed, it blows against the sail switch completing the circuit. The sail switch is placed into the system as a safety to prove there is adequate air for combustion.



The limit switch is an in line safety device which protects the furnace from any over heating conditions. The contacts in the limit switch open at a given temperature setting, shutting off power to the valve.



The next section of operation is controlled by the valve and pilot. Once the power is applied to the valve, the following steps are:

1. Set gas valve knob to the pilot setting to light the pilot.
 - a. light pilot.
2. Set gas valve knob to the ON position for burner operation.
3. While ON stand by, if the pilot goes out and the thermostat closes, the blower will come on, but the valve will remain closed. At this time, the pilot must be relit for burner operation.

Note: The blower will remain running until the thermostat contact opens.



As the thermostat senses the room air temperature, the contacts will open removing power from the valve which will shut off the gas. The blower will remain on until the heater coil within the relay cools and the relay opens and stops the current flow to the motor.

- A - Thermostat
- B - Relay
- C - Breaker
- D - Motor
- E - Sail Switch
- F - Limit
- G - Electrical Switch
- H - DSI Board

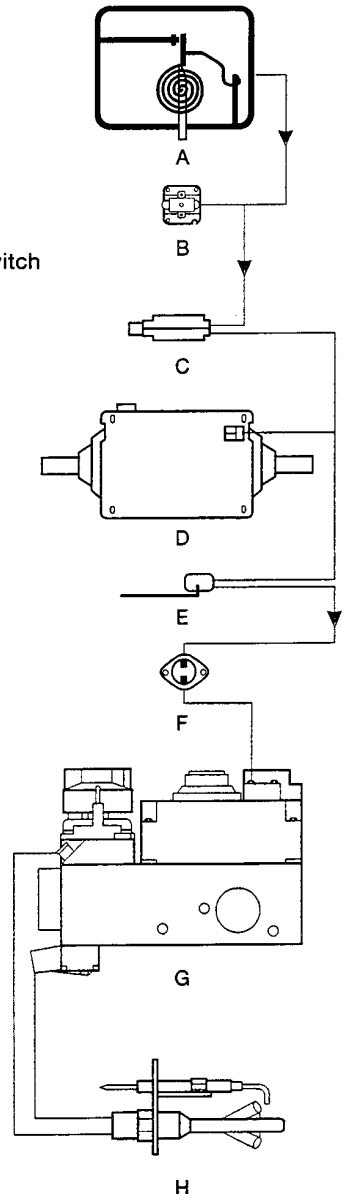

CRITICAL INSTALLATION CRITERIA

WARNING

- Do not install the furnace on material that restricts return air, such as carpet, or any soft material, such as vinyl.
- Do not install furnace where clearance to combustibles cannot be maintained.
- Do not modify the furnace in any way.
- Do not alter the furnace for a positive grounding system.
- Do not HI-POT this furnace unless the electronic ignition system (DSI Board) has been disconnected.
- Do not use a battery charger to supply power to DC model furnace even when testing.
- Do not use 120 volt AC current with DC models.
- Do not use the furnace cabinet area as a storage compartment.
- Do not vent this furnace with a venting system serving any other appliance.
- Do not vent this furnace to an outside enclosed porch area.
- This furnace is not to be used for temporary heating of buildings or structures under construction.
- Locate the furnace in an area that will not be blocked by snow.
- Locate the furnace in an area where the flue gases will not cause building materials to degrade over time.
- Install furnace so electrical components are protected from water.
- Do not use closeable registers when minimum ducting cannot be maintained.
- Wire furnace direct to battery when possible.
- Use a minimum of 22 gauge wire for the thermostat.
- Use a minimum of 18 gauge wire to the furnace from power supply.
- Follow wiring color code exactly.
- Hold both fittings with a wrench when tightening gas connection.
- Always meet or exceed minimum duct requirements.
- Always meet minimum return air requirements.
- Isolate return air passage from range compartment.

WARNING

CARBON MONOXIDE POISONING

- Furnace must be installed and vented to these instructions.
- Improper installation, adjustment, alteration, service or maintenance can cause injury or property damage.
- Negative pressure produced by the furnace can affect the combustion air or venting of other appliances if installed in an improper location.

For assistance or additional information, consult a qualified installer, service agency or gas supplier.

ANNUAL PREVENTATIVE MAINTENANCE INSPECTION

The following preventive maintenance and safety checks should be performed by a qualified RV technician once a year, or more, depending on the use of the furnace. Failure to properly maintain the furnace may void the furnace warranty and can result in unsafe furnace operation. Preventive maintenance is not covered under warranty.

WARNING

- Installation, repairs and preventative maintenance should be done by a qualified service person only.
- The furnace should be inspected before use and at least annually by a qualified service person.
- Frequent cleaning may be required due to excessive lint from carpeting, bedding material, pet hair, etc. It is imperative that control compartments, burners and circulating air passageways of the furnace be kept clean.

WARNING

- Label all wires prior to disconnection when servicing. Wiring errors can cause improper and dangerous operation. Verify proper operation after servicing.

AIR WHEEL

The air wheel should be clean and clear of obstructions. Starting the furnace with something in the blower will damage the wheel, making replacement necessary.

BURNER

The Burner requires no adjustments, but should be inspected annually. Burners should be cleaned with a wire brush to remove debris and corrosion build up.

COMBUSTION CHAMBER

Check the air intake and flue areas of the furnace for internal obstructions, such as wasp or bird nests. The life of the combustion chamber is a function of the amount of time that the furnace has operated. Therefore, it is essential to inspect the chamber for cracks and holes. Have the chamber replaced if it has any cracks or holes - this condition is not field repairable. Chamber should be cleaned if obstructions are present, by removing the chamber and flushing the unit out with water.

CONTROL COMPARTMENT

Clean the control compartment to remove dirt and lint.

DUCTING

The heat ducts should be clean and clear of obstructions. Check for proper duct connection. Any ducts disconnected from the furnace or outlets must be reattached.

GAS PRESSURE

Using a U-tube water manometer, with the furnace and all of the gas appliances operating, the pressure should be 11" W.C. (27mbar). Improper gas pressure can cause the furnace to work inconsistently and create unbalanced combustion.

GAS SUPPLY SYSTEM

Perform a pressure-drop test according to current ANSI standards, to insure that there are no gas leaks.

GASKETS

Inspect all gaskets for tight seals. Do not reuse gaskets - always replace with new.

GENERAL

Check that the physical support of the furnace is sound and without sagging, cracks, gaps, etc.

MOTOR

The motor is lubricated and permanently sealed. It requires no oiling. Brushes and armatures are not replaceable.

RETURN AIR

The return air passage should be clean and clear of obstructions and meet the minimum square inches as specified in the installation instructions. Make sure combustibles are not stored in the furnace compartment. Filters are not recommended at these air passages.

VENTING

After checking and clearing, if necessary, the draft cap assembly must have the proper overlap between the exhaust tube and the furnace chamber tube. Any air leakage at these joints may cause improper combustion. Draft cap assembly must overlap no less than 1-1/4" (32mm), and be positioned against the door screen for proper function.

VOLTAGE

Voltage should be between 10.5 and 13.5 VDC at the furnace during operation. The power at the furnace needs to be checked with each of the following power sources when applicable: generator, battery, and converter. Low voltage can cause the furnace to overheat and cycle. High voltage can cause unbalanced combustion, and excessive motor wear. Note: To increase motor life the furnace should be wired directly to the battery.

WIRE CONNECTIONS

Check the furnace for loose or disconnected wires.

Thermostat

WHAT IS A THERMOSTAT?

- It is an ON/OFF switch controlled by a bi-metal coil which opens and closes an electrical contact by sensing changes in the ambient temperature.
- With its contacts close, it supplies power to the time delay relay which in turn closes a contact that sends power to the blower motor.
- Normally, the thermostat contacts are closed if the blower is running.
- The hydro flame thermostat is equipped with a heat anticipator which allows one to adjust the length of the heating cycles. A furnace should cycle 5-6 times an hour.
 - a. The anticipator is set at 1.0 on all hydro flame thermostats. If you want to shorten the heating cycle, move anticipator to a lower amp setting. You should not set lower than .48 which is the amperage rating of the gas valve. Setting any lower could burn out the anticipator wire.

Note: Heat anticipator adjustments are not covered under warranty.

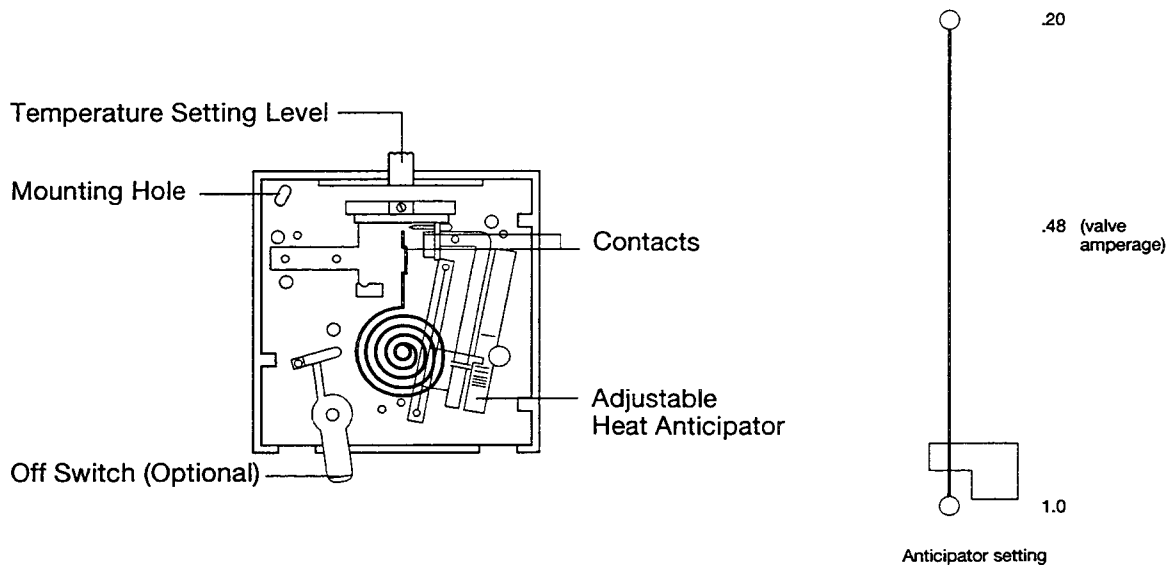

Heat/cool thermostats are being used in conjunction with air conditioners and our furnace. The warranty, installation instructions and diagnostic information is provided by the manufacturer of the thermostat.

THERMOSTAT LOCATION

- It should be on an inside wall 48"-54" above the floor on an inside wall.
- It should not be near areas of extreme heat or cold.
- It should not be located directly across from a heat duct.
- If installed on an outside wall, a 3/4" spacer must be used behind legs of thermostat. This will allow the thermostat to sense the air temperature and not the temperature of the wall.
- A minimum of 22 gauge wire should be used to connect the thermostat to the furnace. We recommend 18 gauge stranded wire.

Circuit Breaker & Motor

The circuit breaker is actually a re-settable heat sensitive device designed to protect the blower motor. In a furnace, this heat evidences itself in the form of an amp draw. Therefore, since there are different size motors, there are different ratings on circuit breakers.

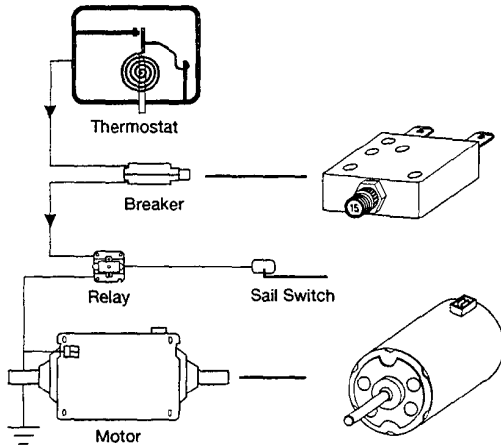

The breakers used on our furnaces are externally mounted and are of a slow blow style. This means that due to their location on our furnaces, the heat of the furnace cannot affect their operation. Likewise, short amperage spikes will not cause them to trip either. The motor will have to produce an excessive and prolonged amperage draw to trip it.

When a circuit breaker trips, it does so because a problem exists. After re-setting it, amperage draw should be taken to determine where the problem is.

On late model 79 and 85 series furnaces, the circuit breaker is now combined with the gas valve ON/OFF switch.

As stated earlier, there are different size motors as well. They are different because they must be compatible with the various BTU capacities. Each BTU of furnace requires a specific motor RPM in order for proper ignition and combustion to take place.

Since it is very important that the proper motor be used for a specific model of furnace, you must identify if you have the correct motor. To help identify a motor, a 'PF' number is embossed in the metal housing of the motor. If you look at the parts reference in the back of this manual, not only are the proper hydro flame part numbers for the motor needed on a specific furnace noted, but the corresponding 'PF' number is also shown.

A new motor has been introduced into all of the 85 and 89 series DC furnaces. This new motor design is hard-wired. As a result the brushes are longer and should increase motor life considerably. As a result, the motor kit will now contain a motor mount bracket, the motor and installation instructions and will add a little more time to the installation process. However, these are the only motors that will be available as replacements in the field.

Circuit Boards

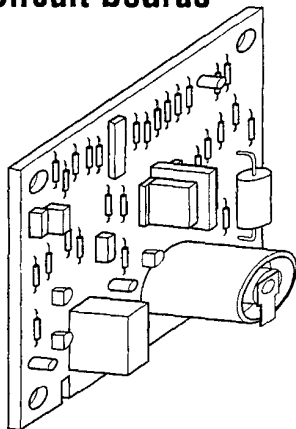

The circuit board has three functions: create a spark, open the gas valve and lock-out when one of the prior two functions do not occur during the ignition cycle. As long as the circuit board is receiving the minimum micro-amps from the electrode assembly, it will not lock out. It has a 15 second ignition delay as well. This delay allows the furnace to purge any unburnt gas in the combustion chamber before ignition occurs.

We have used two basic types of circuit boards. The first is the remote sense analog circuit board that we have used for a number of years. It is a single trial ignition board that works in conjunction with a dual or remote sense electrode (an electrode that has a separate porcelain/sensing probe and a separate porcelain/sparking probe). The other board, which we have only used for the past year or so is a micro-processor board. It is a three trial ignition board and operates in conjunction with a single or local sense electrode (an electrode that has only one porcelain that both sparks and senses).

Various versions of the 12VDC analog board have been used. The catalog numbers of those boards are noted below. Fortunately, the local sense micro-processor board is the only one you will have to stock for replacement on a 12VDC furnace. Plastic spacers will be provided with the board so that it can be mounted on metal surfaces that you may encounter sometimes.

The only other circuit board that you will have to stock is the AC version and it is now a local sense three trial board as well.

CATALOG #	FENWAL	ORDER SERVICE PART #
05-159007-103	old style, uncovered, 12VD	36716
05-309017-153	uncovered, no legs, single try, 12VDC	36716
06-235132-001	single try, uncovered with legs, 12VDC	36716
05-505650-153	three trial, uncovered, micro-processor, 12VDC	36716
05-299004-153	three trial, AC	35119

Relay

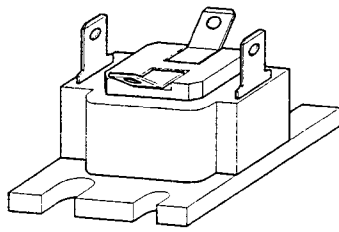

This component is commonly referred to as a time delay relay. The same relay is used on the 7900, 8500 and 8900 series furnaces.

Function - The relay has two functions.

- to purge the combustion chamber of any unburnt gases before the furnace attempts to light.
- to purge the plenum of heat and the chamber of any unburnt gases after each heating cycle.

Operation - The relay circuit is normally open. There should always be voltage from the circuit breaker to the relay terminal of the circuit breaker.

Only when the thermostat contacts are closed is voltage supplied to the thermostat terminal of the relay. This voltage heats a coil in the relay body. In approximately 20 seconds this heated coil causes a bimetal disc to close. Voltage now passes through the relay and on to the motor, which in turn should allow the furnace to ignite and start a heating cycle.

When a heating cycle is complete, the contacts of the thermostat open and voltage ceases to the heater coil of the relay. In approximately 45 - 90 seconds, the heater coil cools down, the bi-metal disc opens and voltage ceases to the motor as well.

AMP Draw - The relay should draw no more than 1 amp. This is why the thermostat anticipator is set at 1.0. If the relay should draw more than 1 amp, it will burn out the anticipator.

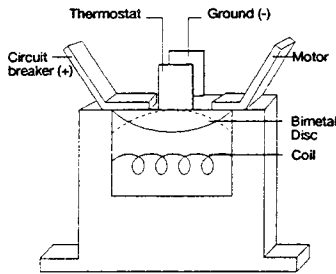

Sail Switch

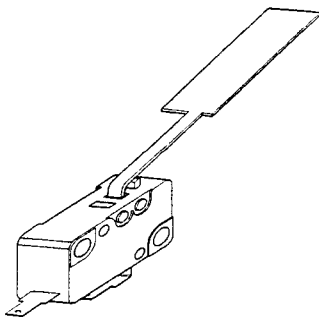

The sail switch is an air proving device. It is a safety component that will not let ignition occur until it sees 75% of the motor's rpm's. It insures that the combustion wheel is rotating fast enough so that there is a proper air and gas mixture for smooth ignition.

There are different size sail switches. The noticeable difference is the size of the paddle on the switch. Each switch is matched to the size of motor it must respond to.

When the paddle of the switch is depressed, there should be continuity through the switch. If a sail switch needs to be replaced, it should be replaced with the exact same size. If a larger switch than the original is used, it will probably not close when the motor reaches 75% of its rpm's and therefore keep ignition from occurring.

The most common problems with these switches are bent paddles, loose wire connections or an obstruction between the paddle and switch contact.

Limit Switch

The limit switch is a very important safety device on a furnace. The function of a limit switch is to protect the heat chamber of a furnace from overheating. These switches come in a variety of temperature ratings and are located at critical locations above the heat chamber on the various models of furnaces. Therefore, it is very important that when one of these switches is replaced, you do so with the properly rated switch.

Failure to do so could cause an unsafe condition with the heating system. When in doubt as to whether you are using the proper limit switch for a furnace, look at the temperature at the base of the switch and match it to the temperature and related switch noted below.

Part Number 36205 is a thermal cut-off and was a specific safety component used on only 89-II furnaces. It was located above the chamber and tripped in the event of a burn through chamber.

79-II, 89-II 89-III
Part # 37021 (34781)
3/16" / 3/16" terminals

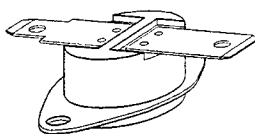

Markings
on Switch

L77
(170°F)

85-II, 89-I
Part # 35132
1/4" terminals

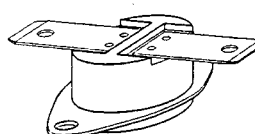

L54
(130°F)

85-III
Part # 37022 (36176)
1/4" terminals

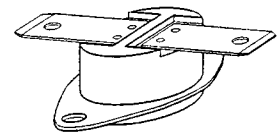

L190
(190°F)

Dual Solenoid Gas Valve

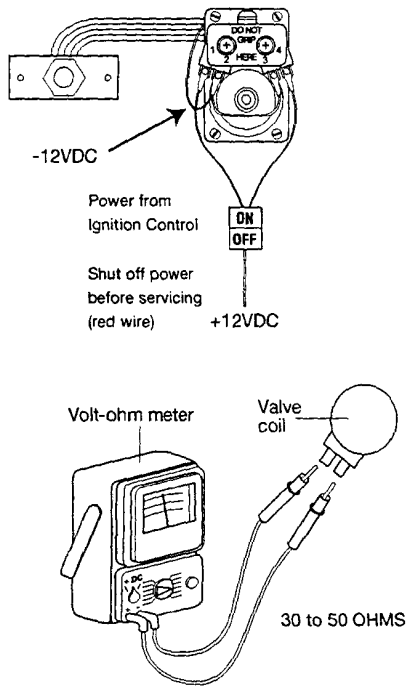

We use a White Rodgers dual solenoid gas valve on all of our furnaces. The valve requires a minimum of 10.5VDC in order to open and when open, should draw no more than .48 amps.

Later model furnaces have an ON/OFF switch on the wire to the gas valve. This replaces the manual shut-off that was used on earlier model furnaces. You can now electrically shut off the gas to the valve with this switch before servicing the furnace.

When these valves become inoperative, it is typically one or both of the coils that fail. In order to determine which coil is at fault, you need to conduct a continuity test on both leads of each coil. The resistance on a good coil will be 30-50 ohms. If the resistance not in this range the coil is defective and must be replaced.

The coils on this valve are wired in parallel. Therefore, when replacing the wires back on these coils, it is important that they be attached per the diagram. The 12VDC supply wires must be attached to terminals 1 and 4 and the ground wires must be attached to terminal 2 and 3. If the coils are mistakenly wired in series, a marginal supply voltage may not allow the valve to open.

Burner Head, Electrode and Valve Assembly

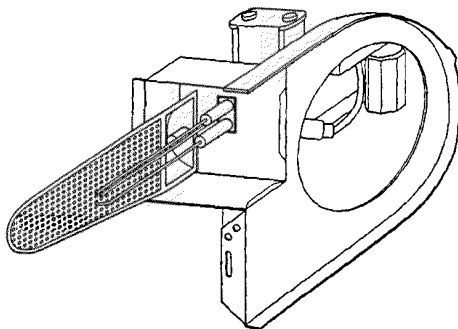

The burner head, electrode and gas valve on the late model 79 series furnace are individually accessible. However, to service these same components on the late model 85 and 89 series, they are more easily serviced by removing the complete assembly as shown in the diagram.

The different models and/or BTU ranges of furnaces use different burner heads. These burners differ by the size of the top gas port holes or the deflector that runs through the throat of the burner. If the wrong one is used, it may cause an ignition, sooting or flame sense problem.

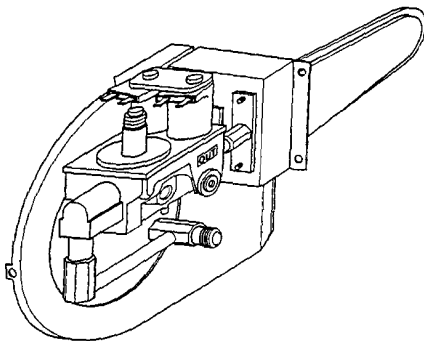

When an electrode assembly is installed on a furnace, they will already be in a fixed and predetermined position above the burner. The only adjustment that you may need to do is on the sparking and ground electrode points. This gap should be 1/8". However, when the porcelain on an electrode assembly becomes cracked, it will not function properly and will have to be replaced. When doing so, use the proper electrode assembly for the model of furnace being serviced.

There are only two versions of the solenoid valve available for the models of furnaces noted above. These two valves are identical except for the gas porting on them (side or front). As stated earlier in this manual though, the coils are what usually breakdown but they are easily replaceable.

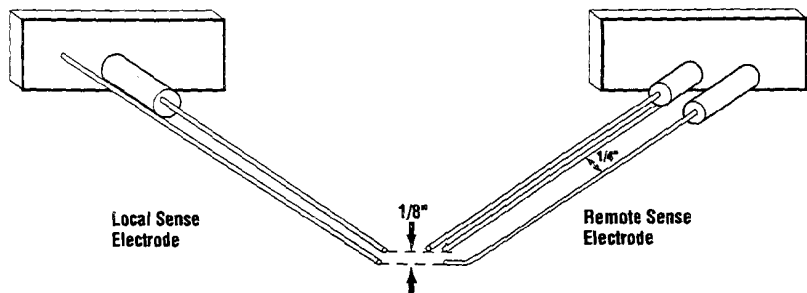

The 4 Always

Remember that you are working on a heating system and not just a furnace. A majority of furnace problems lie outside of the product itself. Therefore, when trouble-shooting a furnace problem, always check the following items before testing or replacing components.

#1 - GAS PRESSURE

The gas pressure should be set at a minimum of 11" W.C. with a minimum of 50% and ideally 100% of the gas fired appliances operating. You should test this pressure with a U-tube Manometer only. If you choose to use a dial-type manometer, calibrate it often with a U-tube manometer.

#2 - VOLTAGE

Voltage to the furnace should be between 10.5 and 13.5 VDC during operation with the interior lights ON and OFF. This check should be made with the battery, converter or generator when applicable. Use a digital or analog multi-meter when taking voltage readings. Do not use a test light. It does not provide enough useful information for proper diagnosis.

#3 - DUCTING

Always make sure that the furnace has at least the minimum number of ducts (not including closeable outlets) called out in the installation instructions. Check for proper duct connections at the furnace and heat registers, collapsed ducts and holes in the ducting. The duct runs must be as straight and tight as possible. The heat ducts must also be clean and clear of obstructions.

#4 - RETURN AIR

The return air passage should meet the minimum square inches as specified for the particular model of furnace in the installation instructions. This air passage should also be clean and clear of obstructions. Do not put air filters in this passage way. Also make sure that combustibles are not stored in the furnace compartment.

#1 - Gas Pressure

A furnace is a consumer's friend when the outside temperature gets colder. Unfortunately though, cold is an enemy of LP gas. The BTU capacity of LP per volume decreases as the outside temperature gets colder. Therefore, based on how full the LP tanks are, the ambient temperature outside and how many BTU's the furnace is, there may not be enough gas to sustain ignition on the furnace.

Using the charts below, let's say that a 40,000 BTU furnace won't fire up, and we also know that the 65 lb. LP bottle on the RV is 40% full and it is 0 degrees F. outside. One's first thought might be that the burner or valve is bad. However, if we use the chart, the vaporization capacity of the tank in these conditions is only 38,500 BTU's. The furnace is not going to perform very well because there is insufficient BTU capacity in the tank.

If you were to put an insulated fire resistant blanket over the tanks and a 75 watt light bulb under that, you would probably raise the temperature of the bottles 10-20 degrees and almost double the BTU capacity of the tank. This in turn would allow the furnace to operate properly. So keep in mind that a furnace problem is not always a component problem.

20 lb. Bottle (*30 lb. bottle multiply X 1.40)

% Full	+20°	0°	-5°	-10°	-15°
60%	36,000	18,000	12,750	8,500	4,250
50%	32,400	16,200	12,150	8,100	4,050
40%	28,800	14,400	11,400	7,600	3,800
30%	25,200	12,600	10,450	7,300	3,150
20%	21,600	10,800	8,100	5,400	2,700
10%	16,200	8,100	6,075	4,050	2,025

65 lb. Under Mtd. LP Gas Tank BTU available at

% Full	+20°	0°	-5°	-10°	-15°
60%	95,600	47,800	36,000	23,900	12,100
50%	86,000	43,000	32,250	21,500	11,750
40%	77,000	38,500	29,250	19,250	9,625
30%	68,000	34,000	25,500	17,000	8,500
20%	58,000	29,000	21,750	14,500	7,250
10%	43,200	21,600	16,200	10,800	5,400

#2 - Voltage:

Explained sufficiently under the 4 Always.

#3 - Minimum Ducting Requirements:

The various BTU sizes of 85 and 89 series furnaces require a minimum number of square inches of heat ducting. The most common size of soft ducting is 4" diameter. Therefore, since a 4" duct is equal to 12 square inches, we can call out the minimum number of ducts needed for the models of furnaces noted below.

Furnace Model	Minimum Ducting	Minimum Ducts
8516, 8520, 8525	24 sq. in.	2
8531, 8535	36 sq. in.	3
8935, 8940	48 sq. in.	4

Ducting Locations 85 and 89 Series

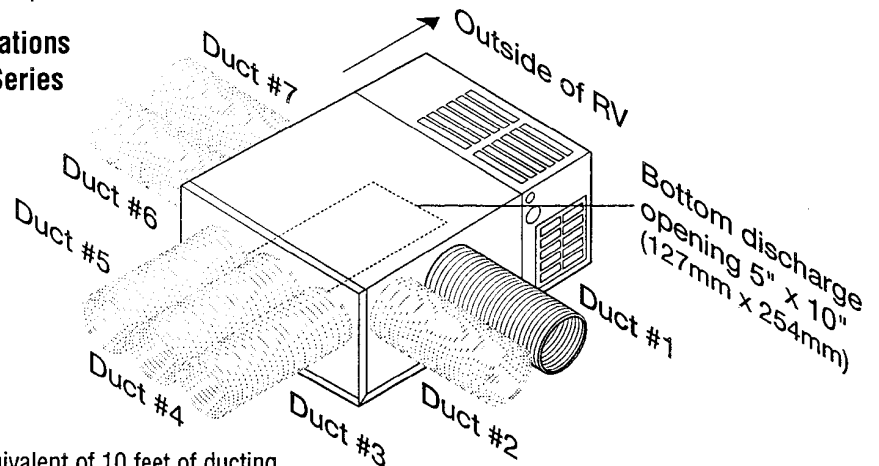

CAUTION - Ducting Installation

4" Flexible Hose

- each 90° bend adds the equivalent of 10 feet of ducting
- ducting should be securely attached to furnace
- each run should be as straight and short as possible

2" Flexible Hose

- 2 - 2" duct runs do not equal one 4" duct. A 2" duct is only 3 sq/inches
- 2" duct adapters are available
- 2" ducts are ideally suited for bathroom and holding tank compartments

Closeable Outlets

- a closeable outlet does not contribute to the minimum of total outlets recommended for a furnace.

Bottom Discharge

- furnace must be completely sealed to floor and plenum with a bottom discharge gasket, with no air gaps.
- if furnace is installed in middle of run, the main duct run must be a minimum of 24 sq/inches.
- if furnace is installed at the end of the run, the main duct must be 48 sq/inches.

#4 - Return Air

This return air requirement can be met in a couple of ways.

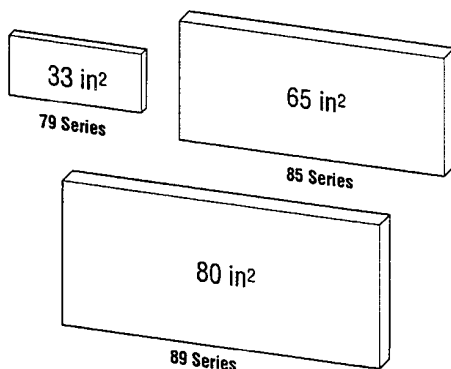

- The return air grille mounted on an inside wall of the trailer, exposed to the cabinet area of the furnace is the most common mounting used on the 85 and 89 Series furnaces.
- Another option is to provide openings at various locations in the furnace cabinet area capable of drawing air from inside the trailer (ie. rowtered holes at bases of sofas or walls, etc.).

The total square inches of openings must meet minimum requirements.

Do not place any types of air filters in front of or behind the return air door. Blocking this area will substantially decrease the return air causing - less air delivery to the heat registers - short cycle of the furnace - limiting of the furnace.

We recommend electrical air filters that can be placed anywhere in the open living area of the recreation vehicle. They can be purchased in most hardware stores.



Effective: 8/23/97

Guides are only intended for use on Atwood® products by service technicians who have successfully completed Atwood® training. This guide should be used in conjunction with the appropriate Instruction Manual provided with the product and any applicable Industry Standards. This is not intended to be a complete list. Please direct questions concerning service of Atwood® products to 800-825-4328 before proceeding.

CAUSE	SOLUTION
BLOWER DOES NOT RUN	
Temperature selector out of place	Re-set to desired position
Thermostat wires broken or disconnected	Not covered under warranty.
Heat anticipator burned out	Dead short (not covered under warranty). Repair short and then replace thermostat. Faulty relay drawing more than 1 amp. Replace relay and thermostat. Covered under warranty.
No continuity through thermostat with contacts closed and switch on.	Replace thermostat.
Continuity through thermostat with contacts closed and switch on.	<ul style="list-style-type: none"> • Check and reestablish power to thermostat • Reset tripped circuit breaker. • Correct poor ground. • Correct any loose wires. • Replace defective relay. • Replace defective motor.
Furnace cycles too quickly	Move anticipator to a higher amp setting to lengthen cycle. NOT covered under warranty. Thermostat located too close to a heat duct. Move thermostat or duct outlet. NOT covered under warranty.
High temperature variance	Move anticipator to a lower amp setting to shorten cycle. NOT covered under warranty.

Note: When the anticipator is set properly and the heating system has operated for a few hours, the furnace should cycle 5-6 time per hour.

Effective: 8/23/97

Guides are only intended for use on Atwood® products by service technicians who have successfully completed Atwood® training. This guide should be used in conjunction with the appropriate Instruction Manual provided with the product and any applicable Industry Standards. This is not intended to be a complete list. Please direct questions concerning service of Atwood® products to 800-825-4328 before proceeding.

CAUSE	SOLUTION
BURNER FAILS TO IGNITE AND - BLOWER FAILS TO RUN	
No electrical power to the furnace	Reconnect or replace power source.*
Thermostat defective	Replace thermostat
Thermostat wires broken or shorted	Replace wire or wires*
Current overload protector device defective or tripped (circuit breaker).	Reset circuit breaker. Check amp draw from motor according to furnace's specifications.
Blower relay defective	Replace relay
Wire off motor	Reconnect wire
Wire off relay	Reconnect wire
Improper ground	Clean and secure grounds*
Blower motor defective	Replace motor
BLOWER RUNS - BUT FAILS TO IGNITE	
Low Voltage	Correct Power Supply*
Gas pressure incorrect	Set pressure to a minimum of 11" W.C. with all appliances running. (Replace regulator if not obtainable).*
Furnace grounding wires not secure	Clean and secure grounds established*
Air intake restricted	Clean air intake.*
12 volt polarity reversed	Correct polarity*
Motor running slow	Check voltage first. If 12 VDC while running, replace motor.
Exhaust blocked	Clean exhaust.*
Combustion air wheel loose	Reposition and tighten.
Sail switch defective or wire off	Reconnect wire or replace.
Limit switch defective or wire off	Reconnect wire or replace.
Edge connector on circuit board dirty	Clean with pencil eraser*
Circuit Board defective	Clean plug contacts. If still defective, replace. (check on board tester when possible).
Gas valve defective	Replace valve or valve coil, depending on problem encountered.
Main burner orifice blocked	Clean main burner orifice or replace.
High tension lead wire defective	Replace wire
Electrode out of adjustment	Adjust electrode (take care not to damage porcelain).
Electrode defective	Replace
Obstructed burner head	Clean burner head*
BURNER IGNITES BUT IGNITION SYSTEM "LOCKS OUT" AND TURNS BURNER OFF	
Low gas pressure	Set pressure to a minimum of 11" W.C. with all appliances running. Replace regulator if not obtainable.*
Exhaust blocked	Clean exhaust.*
Combustion air wheel loose	Reposition wheel and tighten
Electrodes out of adjustment	Adjust electrode according to furnace specifications.
Electrode defective	Replace electrode.
Circuit Board defective	Clean plug contacts. If still defective, replace. (Check on board tester when possible).
Flame sensor wire between electrode and circuit board defective	Replace wire
Air leakage at gaskets	Replace gasket
Defective heat exchanger	Replace heat exchanger

*indicates NOT covered under warranty.

continued backside 28

CAUSE	SOLUTION
BURNER FAILS TO IGNITE AND - BLOWER FAILS TO RUN	
No electrical power to the furnace	Reconnect or replace power source.*
SOOTING (caused by lazy yellow flame)	
Low gas pressure	*Set pressure to a minimum of 11" W.C. with all appliances running. Replace regulator if not obtainable.
Low voltage	Correct power supply*
Air leakage at gaskets	Replace gaskets
Combustion wheel installed backwards	Reposition wheel and tighten.
Blockage in heating chamber or burner head	Clean or replace
Faulty motor	Replace motor
FAN RUNS CONTINUOUSLY WITH THERMOSTAT "OFF"	
Defective thermostat	Replace thermostat
Shorted thermostat leads	*Replace wire or wires.
Defective relay	Replace relay
LIMITING = BURNER CYCLING ON AND OFF - BLOWER RUNS CONSTANTLY WITH THERMOSTAT ON	
Furnace over fired	Set gas pressure to a minimum of 11" W.C. with all appliances running replace regulator, if not obtainable. Also, check main burner orifice, it must comply with furnace's specifications.*
Restricted return air supply	Make sure return air meets furnace minimum requirements.*
Restricted or insufficient discharge ducting	a. Ducting must meet furnace's minimum requirements.* b. No excess ducting or unnecessary bends.* c. All closeable registers must be fully open and unrestricted.*
Defective limit switch	Replace limit switch
BLOWER SHUTS OFF AT SAME TIME BURNER SHUTS OFF	
Wired wrong	*Correct wiring
Faulty relay	Replace relay.
BLOWER VIBRATES OR IS NOISY	
Motor mount loose	Tighten motor mounting bracket a. Ducting must meet furnace's minimum requirements* b. No excess ducting or unnecessary bends.* c. All closeable registers must be fully open and unrestricted.
Damaged blower wheel	Replace blower wheel.
Motor shaft bent	Replace motor
INSUFFICIENT HEAT	
Furnace under fired	1. Set gas pressure to 11" W.C. with all appliances running, replace regulator if not obtainable. Also, check main burner orifice, it must comply with furnace's specifications. 2. Check ducting and return air according to furnaces specifications.*



Atwood Mobile Products
WORLD HEADQUARTERS
 4750 Hiawatha Drive
 Rockford, IL 61103-1298



FURNACE - Pilot Model

TROUBLE SHOOTING GUIDE

Effective: 8/23/97

Guides are only intended for use on Atwood® products by service technicians who have successfully completed Atwood® training. This guide should be used in conjunction with the appropriate Instruction Manual provided with the product and any applicable Industry Standards. This is not intended to be a complete list. Please direct questions concerning service of Atwood® products to 800-825-4328 before proceeding.

CAUSE

SOLUTION

BURNER FAILS TO IGNITE AND - BLOWER FAILS TO RUN

No electrical power to the furnace	Reconnect or replace power source.*
Current overload protector device	Reset circuit breaker. Check amp draw from motor defective or tripped (circuit breaker).according to furnace's specifications.
Thermostat defective	Replace thermostat.
Thermostat wires broken	Replace wire or wires.
Thermostat located in high area	Relocate thermostat.
Blower motor defective	Replace motor.
Blower relay defective	Replace relay.
Wire off motor	Reconnect wire.*
Wire off relay	Reconnect wire.*
Improper ground	Clean and secure grounds.*

BLOWER RUNS - BUT FAILS TO IGNITE

Low Voltage	Correct power supply.*
12 volt polarity reversed	Correct polarity.*
Furnace grounding wires not secure	Clean and secure grounds established*
Gas valve defective	Replace valve or valve coil, depending on problem encountered.
Gas pressure incorrect	*Set pressure to a minimum of 11" W.C. with all appliances running. (Replace regulator if not obtainable).
Limit switch defective or wire off	Reconnect wire or replace.
Sail switch defective or wire off	Reconnect wire or replace.
Burner orifice blocked	Clean main burner orifice or replace.
Combustion air wheel loose	Reposition and tighten.
Burner head adjustment	Reposition and tighten. Adjust burner according to furnace specifications.
Exhaust blocked	Clean exhaust.*
Air intake restricted	Clean air intake.*
Broken or loose wire	Replace or tighten*
Motor running slow	Check voltage first. If 12 VDC while running, replace motor.*

BLOWER SHUTS OFF AT SAME TIME BURNER SHUTS OFF.

Faulty relay	Replace relay
Thermostat wired wrong	Correct wiring*

BURNER CYCLING ON AND OFF - BLOWER RUNS CONTINUOUSLY WITH THERMOSTAT "ON"

Restricted return air supply	Make sure return air meets furnace's minimum requirements.
Restricted discharge duct system	a. Make sure ducting meets furnace's minimum requirements.* b. Make sure there is no excess ducting or unnecessary bends.* c. Make sure any closeable registers are fully open and unrestricted.
Defective limit switch	Replace limit switch.*
Furnace over fired	Set gas pressure to a minimum of 11" WC with all appliances running. Replace regulator if not obtainable. Also, check main burner orifice, it must comply with furnace's specifications.

*indicates NOT covered under warranty.

continued backside

CAUSE	SOLUTION
BURNER FAILS TO IGNITE AND - BLOWER FAILS TO RUN	
No electrical power to the furnace	Reconnect or replace power source.*
BLOWER VIBRATES OR IS NOISY	
Damaged blower wheel	Replace blower wheel.
Motor shaft bent	Replace motor
Loose motor	Tighten motor mounting bracket.
Restricted discharge duct system	a. Make sure ducting meets furnace's minimum requirements.* b. Make sure there is no excess ducting or unnecessary bends.* c. Make sure any closable registers are fully open and unrestricted.*
PILOT FAILS TO IGNITE OR STAY LIT	
Plugged pilot orifice	Clean or replace pilot orifice.
Electrode out of adjustment	Adjust electrode to furnace's specifications.
Pilot tube defective	Replace tube.
Piezo sparker defective	Replace sparker
Defective thermocouple	Replace thermocouple.
Defective valve	Replace valve.
Vent kit not sealed	Seal vent where it meets with the furnace.*
MICA window missing	Replace MICA
Combustion air hose plugged or collapsed	Replace combustion hose
Water in propane	Add alcohol to the propane bottles.*
Burner plate gasket or pilot gasket not sealed	Replace gaskets
LAZY FLAME (yellow)	
High gas pressure	*Set pressure to a minimum of 11" W.C. with all appliances running. Replace regulator if not obtainable.
Burner out of adjustment	Adjust burner according to furnace specification.
Combustion wheel installed backwards	Reposition wheel and tighten.
Air leakage at gaskets	Replace gaskets
Low voltage	Correct power supply*
FAN RUNS CONTINUOUSLY WITH THERMOSTAT "OFF"	
Shorted thermostat leads	Replace wire or wires.
Defective relay	Replace relay
Defective thermostat	Replace thermostat
INSUFFICIENT HEAT	
Furnace under fired	1. Set gas pressure to 11" W.C. with all appliances running, replace regulator if not obtainable. Also, check main burner orifice, it must comply with furnace's specifications.* 2. Check ducting and return air according to furnaces specifications.
Furnace limiting	Check ducting and return air. It must comply with furnace's specifications.*

*indicates NOT covered under warranty.

FURNACE TERMINOLOGY

Terminology	Definition	Terminology	Definition
AC Motor	A Motor operating on 120 volts A.C.	Fan Switch	A normally open switch that closes at a set temperature allowing power flow to the motor, and allows the motor to run after the burner shuts down to cool down the combustion chamber.
Adjustable Register	A heat outlet capable of being opened and closed.	Field Electrical Hook Up	The Wiring Harness that connects the furnace to the coach wiring.
Air Speed Indicators	(Velometer) A tool used to measure the velocity of air movement from a duct outlet.	Flair Fitting	Brass fitting used to connect the furnace to the gas supply.
Ambient Air Temp.	Current room air temperature.	Flash Back	A condition when the flame burns on the inside of the burner.
AMP Draw	The amount of current required to run a given component.	Flex Ducting	A round, collapsible, wire reinforced product used to deliver the heated air from the furnace to the living area.
Burn Off	The time it takes for the furnace Combustion Chamber to burn off all the oils and lubes used in production.	Forced Combustion	A type of combustion when a second air wheel is used to force air into the burner to increase the air to gas mixture.
Burner	The component in the furnace where combustion occurs creating the main source of heat within the Combustion Chamber.	Gas Pressure	The amount of gas being supplied to the furnace, measured in column inches.
Burner Flame Lift Off	When the flame lifts off the Burner.	Gas Valve	A mechanical device by which the flow of gas is started or stopped by an electrical signal.
Candling	A small flame at the Main Burner Orifice when the Valve is in a closed position.	Gravity Combustion	A type of combustion using no other source but gravity to supply combustion air for the proper air to gas mixture at the burner.
Circuit Breaker	A normally closed switch that automatically interrupts an electrical circuit under abnormal AMP loads.	Hard Ducting	(See Floor Ducting)
Circulating Air	Air drawn into the furnace by the Main Air Wheel then heated and forced out the heat outlets.	Heat Anticipator	Component of a Thermostat that can be adjusted to increase or decrease the length of the heating cycle.
Combustion Air	Air supplied to the Burner specifically for combustion.	Heating Element	(See Combustion Chamber)
Combustion Chamber	The component where combustion occurs and transfers heat to circulating air.	High Tension Lead Wire	The wire carrying the high tension spark from DSI Board to Electrode.
Converter	Component that is used to change 120 VAC to 12 VDC. Available in linear, pharo-resonant.	Incline Manometer	Tool used to measure Static Pressure of the furnace plenum.
Cycling	The normal on and off operation of the furnace controlled by the thermostat.	Junction Box	A box inside or outside of the furnace where electrical connections are made.
DC Motor	Motor operating on 12 VDC.	Limit Switch	A normally closed switch that opens at a set temperature which does not allow the furnace to over heat.
DSI Board	A Circuit Board in the furnace controlling the ignition sequence and proves a flame has been established.	Limiting	A condition caused by over-heating the Limit Switch The burner turns on and off during a heating cycle.
Electrode	Both a conductor establishing an electrical spark at the Burner to ignite the air to gas mixture, and a sensor to signal the DSI Board the flame is established.		

Terminology	Definition	Terminology	Definition
Loud Ignition	A condition where the air to gas mixture is off and the burner lights with a loud noise.	Sooting	A black powder that builds up around the Burner in the Combustion Chamber normally caused by an improper air to gas mixture.
Main Burner Orifice	The Orifice regulating the amount of gas delivered to the Burner.	Start Capacitor	A device giving an electrical boost to start an A/C motor.
Manifold	The tube delivering gas from the Gas Valve to the Main Burner Orifice.	Static Pressure	Amount of pressure inside the Furnace Plenum or Duct caused by the ability to dispel air out the duct outlets.
Manual Reset Switch	A Limit Switch manually reset after reaching it's set temperature.	Thermocouple	Safety device used to generate an electrical signal sent to the Gas Valve to hold the Pilot Flame on.
MicroAMPs:	AMPs sent back to the DSI Board to establish a flame is present.	Thermopile	Safety device much like a Thermocouple. It gives a much higher electrical output, also used to open the Main Valve with a Thermostat.
Millivolts	Voltage created by a Thermocouple or Thermopile.	Thermostat	Device used with the Furnace to regulate the room air temperature.
Multi-Try DSI Board	Circuit Board providing 2 or 3 trials for ignition.	Time Delay Relay	A normally open Relay. When activated closes, sending power to the Blower Motor. When deactivated allows Blower to run for a period of time to cool the Combustion Chamber.
OEM	A manufacture of recreational vehicle, "Original Equipment Manufacture".	Transformer	Device reducing 120 VAC to 24 VAC.
Pig Tail	(see Field Electrical Hook Up)	U-Tube	Tool measuring gas pressure in inches of water.
Pilot Light Assembly	An assembly used to light the burner.	VOM	Meter reading voltages and OHMs resistance.
Plenum	The metal box enclosing the Combustion Chamber directing the heated air to the duct outlets.	Valve Coil	Electromagnetic Coil on the Gas Valve holding and releasing a plunger to start and stop the flow of gas.
Power Supply	A source of electrical power, usually a converter, inverter or battery.		
Primary Air	A portion of the combustion air mixing directly in the Burner at the Main Burner Orifice.		
Resonating	A whining noise created by a Burner with an improper air to gas mixture.		
Return Air	Air pulled into the furnace, heated, force through duct outlets back to the living area.		
Safety Lockout	DSI Board not sensing a flame, cutting power to the Gas Valve.		
Sail Switch	Air prover switch that will engage when the Blower Motor reaches 75% of the rated RPM.		
Secondary Air	Combustion Air that helps complete the combustion after the Burner is on.		
Sensor Wire	Wire carrying an electrical signal from the Electrode back to the DSI Board on a remote sense system.		
Slope Gauge	(see Incline Manometer)		

Manual provided courtesy
Bryant RV Services
www.byantrv.com

All manuals are believed to be released for distribution, and/or in the public domain.

Service manuals provided with the understanding that persons using them are well versed in proper safety practices, and are familiar with basic safety procedures, including, but not limited to safety procedures dealing with 120 volt electricity, high amperage 12 volt circuits an LPG (propane) systems.

If in doubt, consult a professional (better safe than sorry).