

Norcold Repair Guide

Models 442, 443, 452, 453, 462, 463, 482, 483

Section 3

Table of Contents

Page

3-2	General Information and Specification
3-3	Information About Electrical Connections
3-3	Description of Operation
3-4	Location of Control and Components
3-5	Lighting and Operating Instructions
3-6	High Humidity and Interior Lamp Switch
3-7	Parts Function
3-10	Troubleshooting Procedures
3-10	Refrigerator Will Not Ignite Electrically on Propane
3-12	Refrigerator Does Not Indicate that a Flame has been Established
3-13	Burner Flame Will Not Light or Stay Lit
3-15	Refrigerator Overfreezing
3-15	Refrigerator Will Not Operate or Cool on A/C
3-18	Refrigerator Will Not Operate or Cool on D/C
3-21	Wiring Pictorials
3-23	Wiring Diagrams
3-E1	Information on Earlier Versions
3-W1	Wiring Pictorials for Earlier Versions
3-W3	Wiring Diagrams for Earlier Versions

General Information and Specification

OPERATING LIMITS - ALL MODELS

AC Mode: 132 VAC Max., 108 VAC Min.
15.4 VDC Max., 10.5 VDC Min.
DC Mode: 15.4 VDC Max., 11.5 VDC Min.
Gas Mode: 11" W.C. Gas Supply
10.5" W.C. Min. Burner Pressure (High Fire)
15.4 VDC Max., 10.5 VDC Min.

MODELS 442, 443 RATINGS

1050 Btu/Hr Input
LP Gas Mode:
11" W.C. Gas Supply
LP14 Orifice
12 Volts DC control voltage
AC Mode:
110 Volts AC, 200 Watts
DC Mode (3-Way only):
12 Volts DC

MODELS 452, 453 RATINGS

1200 Btu/Hr Input
LP Gas Mode:
11" W.C. Gas Supply
LP14 Orifice
12 Volts DC control voltage
AC Mode:
110 Volts AC, 200 Watts
DC Mode (3-Way only):
12 Volts DC

MODELS 462, 463 RATINGS

1450 Btu/Hr Input
LP Gas Mode:
11" W.C. Gas Supply
LP16 Orifice

12 Volts DC control voltage
AC Mode:
110 Volts AC, 300 Watts
12 Volts DC control voltage
DC Mode (3-Way only):
12 Volts DC

MODELS 482, 483 RATINGS

1500 Btu/Hr Input
LP Gas Mode:
11" W.C. Gas Supply
LP16 Orifice
12 Volts DC control voltage
AC Mode:
110 Volts AC, 300 Watts
12 Volts DC control voltage
DC Mode (3-Way only):
12 Volts DC

CURRENT DRAWS - 442, 443, 452, 453

Relighter - 30 milliamps
AC Heating Element - 1.5 amps at 110 Volts AC
1.7 amps at 120 Volts AC
DC Heating Element - 9.2 amps at 12 Volts DC
10.7 amps at 14 Volts DC

CURRENT DRAWS - 462, 463, 482, 483

Relighter - 30 milliamps
Humidity Heater - 240 milliamps or .24 amps
Interior Lamp (when door open) - 600 milliamps or .60 amps
AC Heating Element - 2.7 amps at 110 Volts AC
2.9 amps at 120 Volts AC
DC Heating Element - 13.8 amps at 12 Volts DC
16.1 amps at 14 Volts DC

Information About Electrical Connection

Electrical Connection 120 Volts AC-400 Series

The refrigerator is equipped with a three prong plug for protection against shock hazard and must be connected into a recognized three prong attachment receptacle. The free length of cord is 24", so it is recommended that the receptacle be located to the left side of the refrigerator (viewed from rear) and approximately 12" from the floor. This allows easy accessibility through the vent door. The cord must be routed so as not to come in contact with the burner cover, flue pipe or any other component that could damage the cord insulation.

⚠ WARNING

DO NOT REMOVE (CUT) GROUNDING PRONG FROM THE REFRIGERATOR AC POWER CORD. REMOVAL OF THIS PRONG CAN RESULT IN A SEVERE ELECTRICAL SHOCK, AS WELL AS VOIDING THE REFRIGERATOR ELECTRICAL CERTIFICATION AND WARRANTY.

12 Volts DC Connection - 400 Series

The 12 volt DC supply is necessary for the flame ignition circuit in the gas mode, the interior light, humidity heater, and to supply power for 3-Way models in the DC mode. The AC mode (2-Way or 3-Way models) operates independently of the 12 volt DC. The DC supply connections are made at the terminal block provided at the rear of the refrigerator. The terminal block accepts wire connections with 1/4" Quick Connect terminals. Correct polarity must be observed when connecting to the DC supply. The distance the current must travel from the battery to the refrigerator

dictates the AWG wire size to be used. Should the wire be too small for the distance, a voltage drop will result. In case of 3-Way models, the voltage drop affects the wattage output of the cartridge heater and resultant refrigerator performance.

OPERATION

Models 442-443-452-453-462-463-482-483

All use a single combination control to determine and regulate the mode of operation (LP GAS or Electric). The control is operated by two knobs, the first to select the mode of operation (LP GAS or Electric); the second, to control the thermostat setting. The control consists of a gas shut off valve, safety valve, thermostat and electric interlock. The interlock prevents the possibility of running on LP GAS and Electric at the same time. The safety valve is built into the combination control, and is designed so that any loss of flame will stop the gas flow to the burner. It is controlled by means of a thermocouple positioned in the gas flame. As long as a flame is detected by the thermocouple, the valve will remain open. In the event of flame failure, the valve closes, shutting off the gas flow. To light or relight the burner, the gas control knob must be depressed or held in until the relighter establishes a flame. The relighter is made active by means of an illuminated rocker switch. When the relighter switch is in the on position it will illuminate, signaling that 12VDC is present and energizing the relighter to send a spark to the burner. It will continue to spark until either a flame has been established or the switch is turned off.

On the 3-Way models (A/C, D/C and LP Operation), there is an A/C-D/C selector switch. To operate the refrigerator on 120VAC, set the mode selector to ELEC and depress the A/C switch. If 120VAC is available, the refrigerator will function on A/C current. To operate the refrigerator on D/C Electric while traveling, leave the mode selector switch in ELEC position, and depress the D/C switch for DC operation.

Electrical Connection - 12 Volt DC

12 volt DC must be connected (see Figure 3.1 below) at all times in order to operate the electronic ignition system, and the interior light and high humidity circuit.

The 12 volt DC power source can be either a 12 volt "deep cycle battery" or the vehicle's converter. Voltage Limits:

- 12 volts DC control voltage
- 15.4 volts DC maximum
- 10.5 volts DC minimum

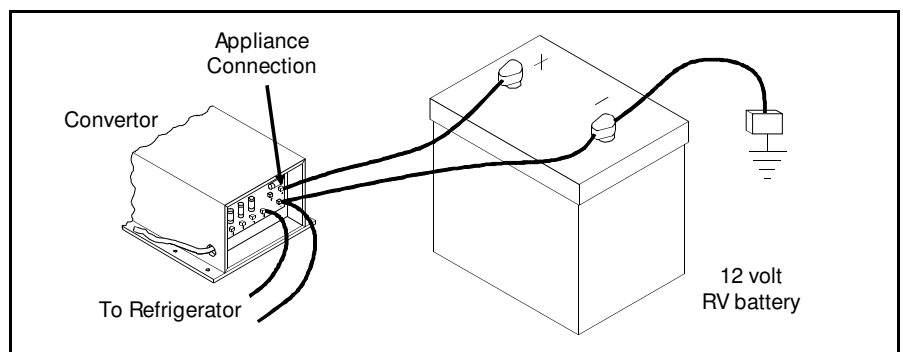

Figure 3.1 Recommended 12 Volt Connection

Component Location and Identification (Single Door Models)

- A. Illuminated Ignition Switch
- B. Flame On Indicator Lamp
- C. Thermostat Control Knob
- D. Combination Control Knob
 - 1. Gas On/Electric Interlock
 - 2. Push-In Safety Valve
- E. AC/DC Mode Selector Switch (3-Way models only)
- F. Serial Identification Plate

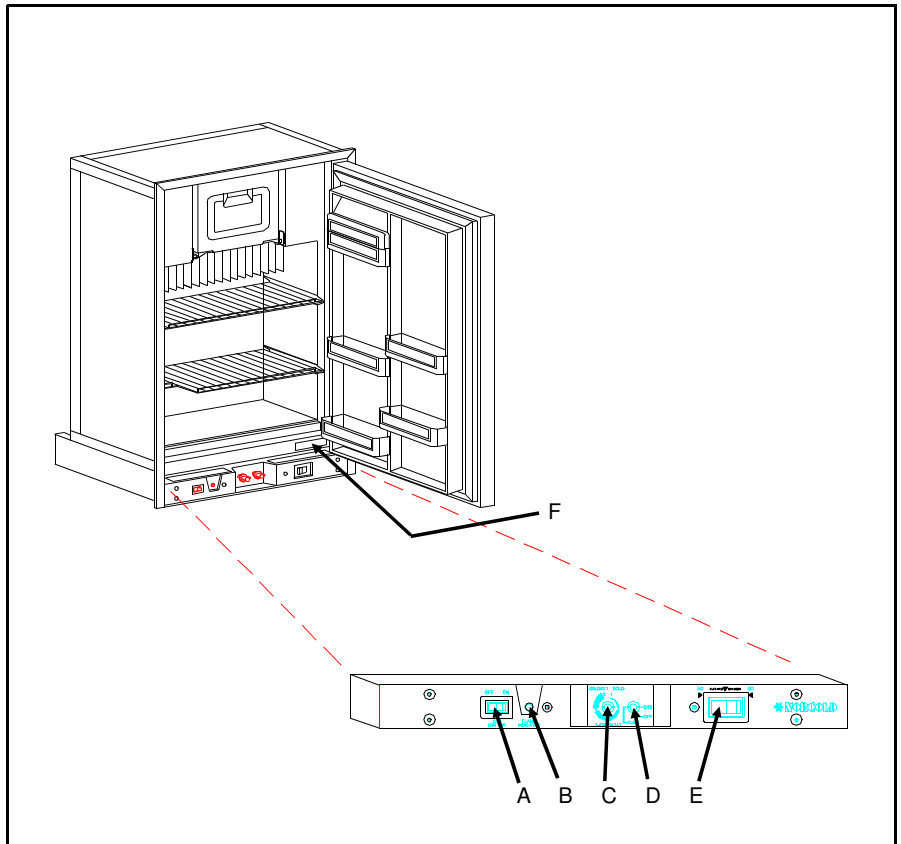

Figure 3.2 Controls Location, Single Door Model

Component Location and Identification (Two Door Models)

- A. Illuminated Ignition Switch
- B. Flame On Indicator Lamp
- C. Thermostat Control Knob
- D. Combination Control Knob
 - 1. Gas On/Electric Interlock
 - 2. Push-in Safety Valve
- E. AC/DC Mode Selector Switch (3-Way models only)
- F. Serial Identification Plate
- G. Three Position Switch (See page 3-6)
 - 1. NORMAL
 - 2. STORAGE
 - 3. HIGH HUMIDITY
- H. Interior Light Switch

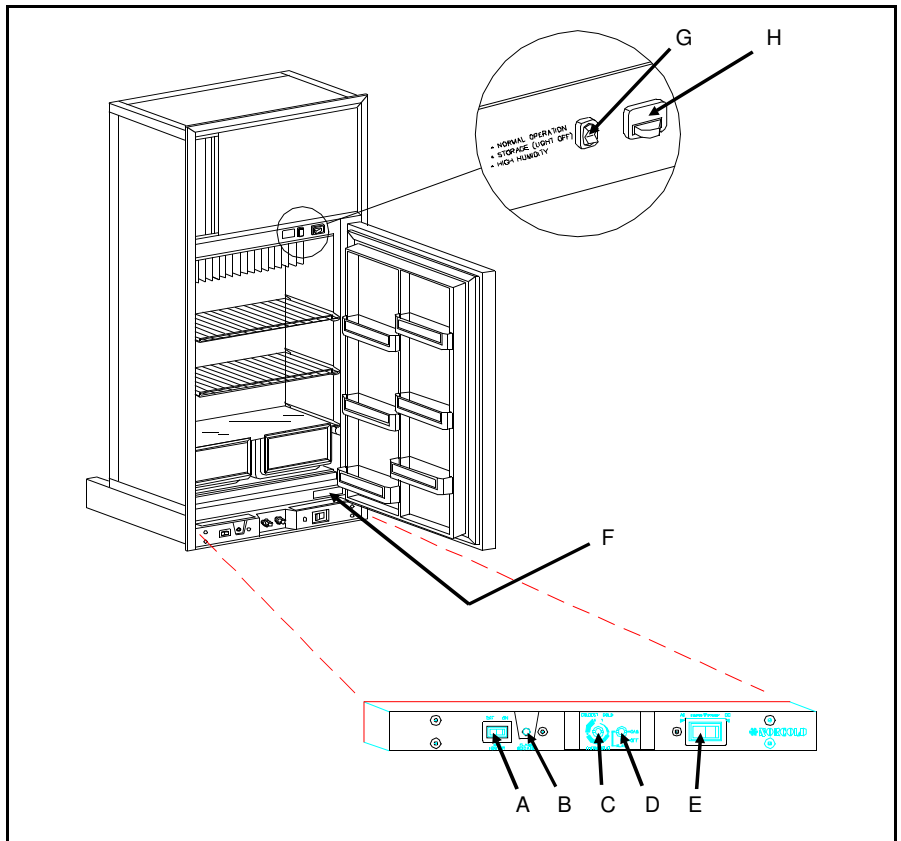

Figure 3.3 Controls Location, Two Door Model

Lighting and Operating Instructions

Lighting Instructions: Gas Operation

1. Make certain that 12 Volts DC is available to the refrigerator.
2. Turn on gas supply at the tank.
3. Set thermostat control to the maximum cold setting.
4. Set ignitor switch to "ON" position. The light located on the switch will illuminate if 12 volts DC is present.
5. Push and turn the "ELEC-OFF-GAS" control counter-clockwise so that knob indicator points to "GAS". Push the control knob and hold it until the flame indicator illuminates (continuous glow). Continue to hold approximately 5 seconds, then release. The flame indicator will remain on. If not, repeat this step.

Note:

The flame should ignite within 10 seconds. On initial refrigerator start-up, it may take longer than 10 seconds to allow air to be purged from the gas line, as indicated by the flame indicator failing to illuminate.

WARNING

DO NOT HOLD GAS CONTROL VALVE IN MORE THAN 30 SECONDS. IF FLAME IS NOT INDICATED WITHIN THIS TIME, TURN GAS TO "OFF", WAIT 2 MINUTES AND RETRY. FAILURE TO DO SO CAN CAUSE GAS TO BUILD UP IN BURNER AREA AND RESULT IN AN EXPLOSION WHICH CAN CAUSE PERSONAL INJURY OR DEATH.

6. Move thermostat control to desired setting.
7. The ignitor switch should be left in the "ON" position during gas operation. If the switch is turned off, the refrigerator will cycle normally. However, in case of flame blowout, the lighter does not function.

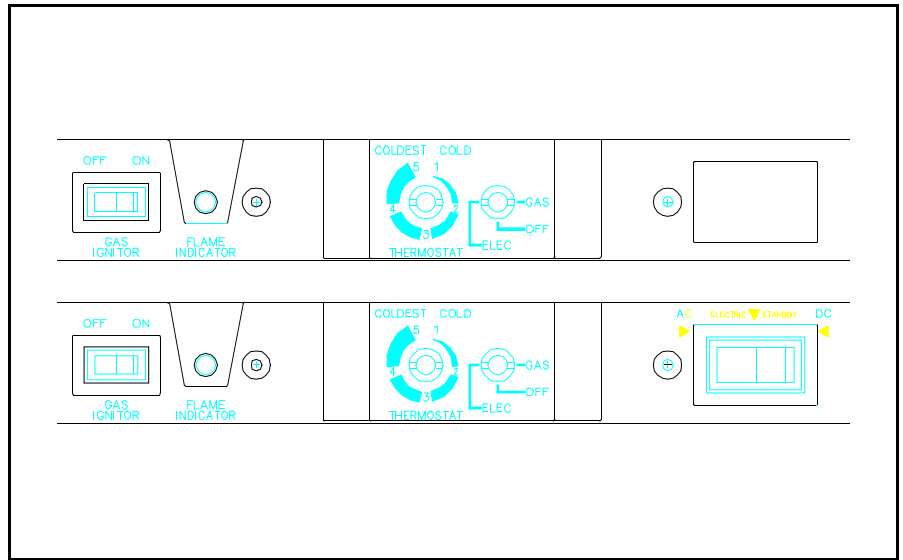

Figure 3.4 2-Way Controls (Upper), 3-Way Controls (Lower)

Start-Up Instructions : AC Electric Operation

1. Make certain that 120 Volts AC is available to the refrigerator.
2. Set the thermostat control to desired setting.
3. Set "AC-DC" switch to "AC" position (3-Way models only).
4. Set ignitor switch to "OFF" position.
5. Push and turn the "ELEC-OFF-GAS" Control clockwise so that knob indicator points to "ELEC". Upon release, note that the knob moves toward you, indicating that the control is locked into electric position.

Start-Up Instructions: DC Electric Operation (3-Way only)

1. Make certain that 12 Volts DC is available to the refrigerator.
2. Set thermostat control to desired setting.
3. Set "AC-ELECTRIC STANDBY-DC" switch to "DC" position.
4. Set ignitor switch to "OFF" position.
5. Push and turn the "ELEC-OFF-GAS" control clockwise so that knob indicator points to "ELEC". Upon release, note that the knob moves toward you, indicating that the control is locked into electric operation.

Operation Note:

Use the "ELEC-OFF-GAS" control to shut off all cooling operation (both Gas and Electric). The "GAS IGNITOR" switch must be shut off independently to prevent unnecessary sparking.

On 3-Way models, use the "ELECTRIC STANDBY" position of the "AC-ELECTRIC STANDBY-DC" switch to temporarily shut off AC or DC operation.

Operation Shut-Down: All Modes

1. Set ignitor switch to "OFF" position.
2. Push and turn "ELEC-OFF-GAS" control to "OFF".

High Humidity - Storage Switch Models 462, 463, 482, 483 Only

Turning this switch to HIGH HUMIDITY will keep the surface between the door openings dry during high humidity conditions. This position will also allow the interior light to activate when the lower door is opened. The switch should be left in the NORMAL OPERATION position unless condensation is observed in this area. Both NORMAL and HIGH HUMIDITY positions allow the cabinet light to activate when the lower door is opened.

Note: (Figure 3.5)

When your RV is being stored for the winter, this switch should be placed in the STORAGE (light off) position and ELEC-OFF-GAS control to OFF. This shuts off all DC power to the light and humidity heater and allows the refrigerator door to be left open for airing without chance of battery drain during storage.

Current Draw

Interior Lamp: 600 Milliamps

Humidity Heat Strip: 240 Milliamps

The interior light, humidity heat strip circuit and relighter is protected by the 3 Amp fuse.

Note: (Figure 3.6)

A short circuit in the interior lamp socket will cause constant fuse blowing.

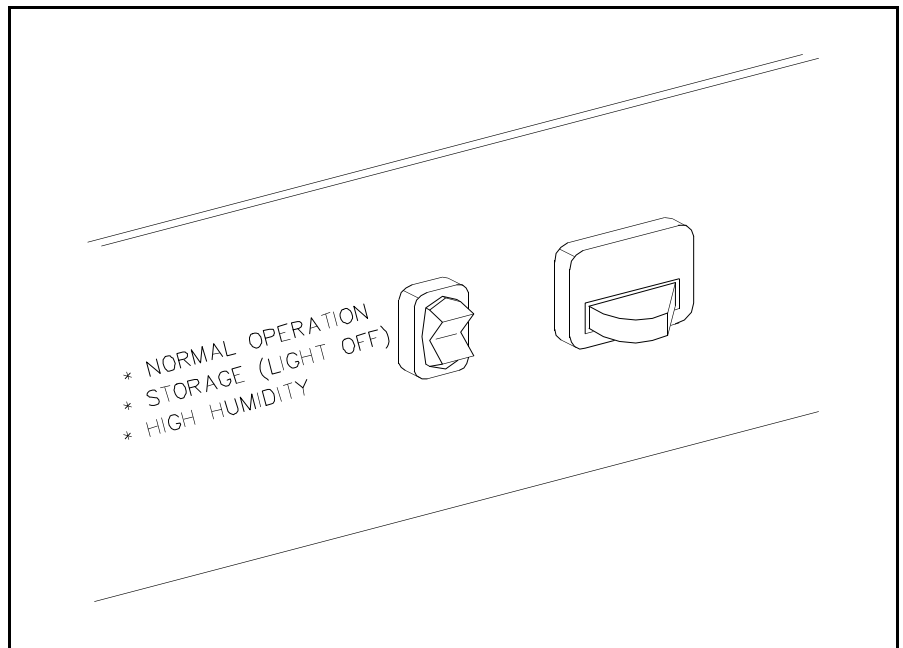

Figure 3.5 Humidity and Light Switch

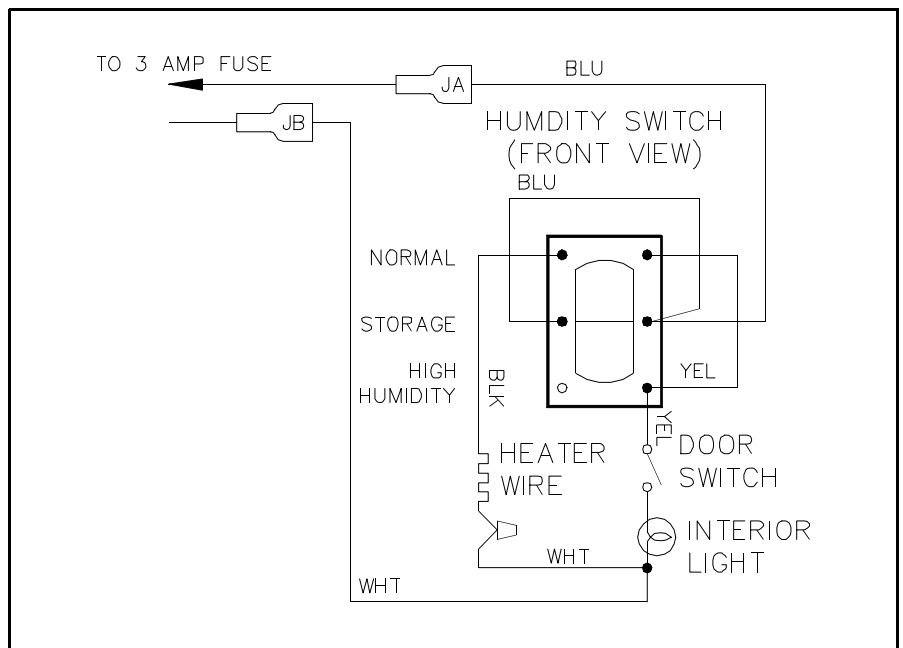

Figure 3.6 Wiring Assembly - Humidity and Light Switch

Parts Function

Combination Control

The 400 Series refrigerators utilize a single combination control to determine and regulate the mode of operation (gas or electric). The control is operated by two knobs. The first is to select the operating mode (gas or electric), and the second is to control the thermostat setting. The control consists of a gas shut off valve, safety valve, thermostat and electric interlock. The interlock prevents the possibility of operating on gas and electric at the same time.

The safety valve is built into the combination control and is designed so that any loss of flame will stop the gas flow to the burner. It is controlled by means of a thermocouple positioned in the gas flame. As long as a flame is detected by the thermocouple, the valve is held open. Upon flame failure (empty propane tanks blowout, etc.) the valve closes, shutting off the gas flow. To light or relight the refrigerator, the gas control knob must be pushed and held in until the ignition establishes a flame. See "Lighting Instructions" on refrigerator.

Note:

The combination control does not have an "OFF" position on the thermostat dial. To check the gas pressure for low fire, set the thermostat to the warmest position, and cool the thermostat capillary tube by use of a component coolant or by placing it in a glass of ice water. This forces the control to low fire. To check for the high fire pressure set the thermostat to the coldest position and allow the capillary tube to get warm.

In the normal gas mode, the combination control modulates the gas pressure to the burner. It modulates between high fire and low fire pressures in response to

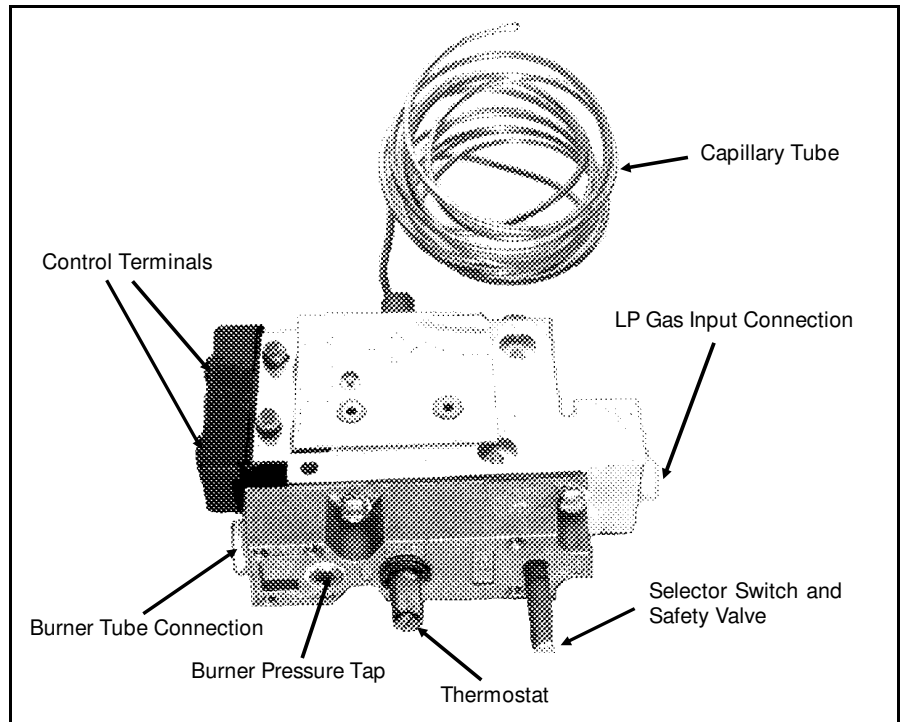

Figure 3.7 Combination Control

the cabinet temperature sensed by the thermostat capillary tube. This modulating burner pressure controls the burner efficiency and in turn, the cooling in the cabinet.

In the normal electric mode, the thermostat opens and closes the microswitch in response to the cabinet temperature sensed by the same capillary tube. The switch contacts will always be closed when the capillary tube temperature is above 50° F. An open switch at this temperature would indicate a broken capillary tube, defective switch or the mode indicator shaft is depressed or hung up.

Ignition Switch

When the ignition switch is turned on, 12 volt DC is applied to the relighter (provided 12 volt DC is supplied to the refrigerator).

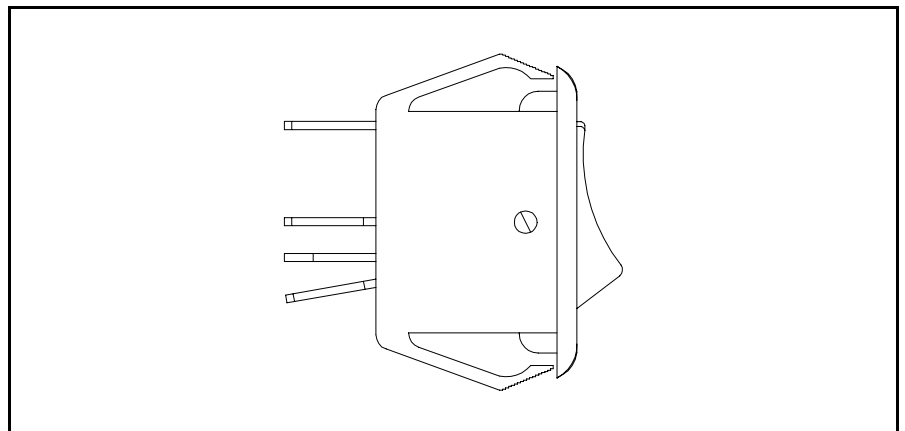

Figure 3.8 Ignition Switch

Relighter

Applies sparking power to the ignition electrode to light the burner and illuminates the flame indicator lamp when a flame is established.

Ignition Electrode

Sends sparks to the burner to light the flame.

Note:

This Norcold is equipped with an electronic ignition relighter. It automatically relights the flame should it blow out. The Ignitor Switch, located on the control panel, activates this relighter. If the switch is turned off after the flame is established, the gas mode operates normally but is without the relight feature.

The User should be aware that the Ignitor Switch must be turned off (green light off) when in electric mode, or else it will continue to cause sparking at the burner.

Thermocouple

Senses the heat of the flame to hold the safety valve open. If there is no flame, it causes the safety valve to close.

Orifice

Applies the correct amount of LP Gas to the burner assembly, when the input pressure is correct.

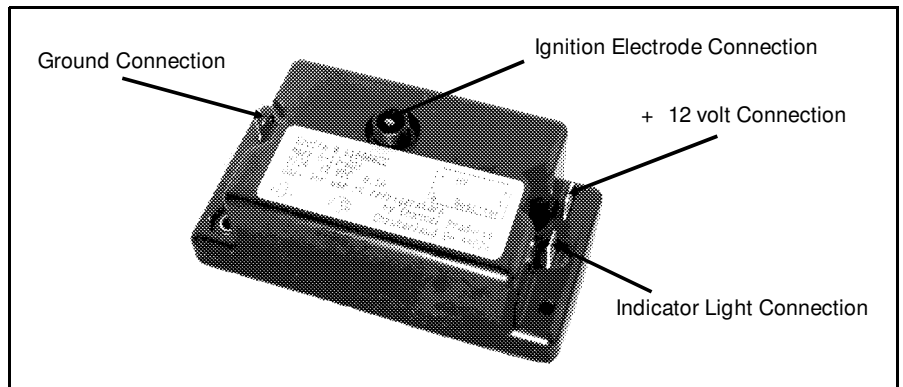

Figure 3.9 Relighter



Figure 3.10 Ignition Electrode

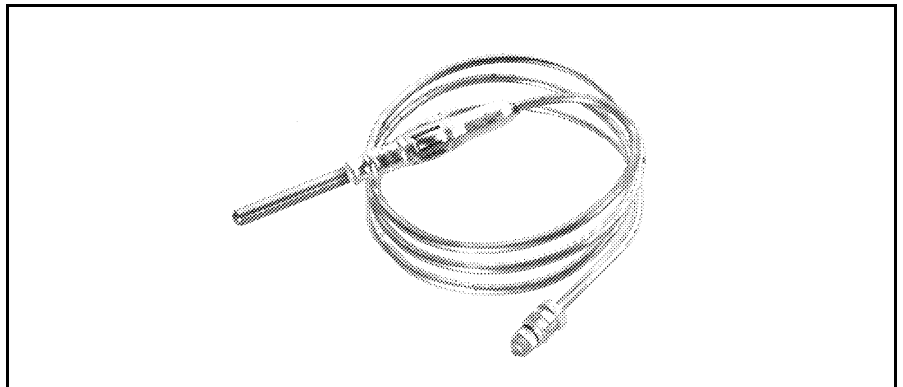

Figure 3.11 Thermocouple

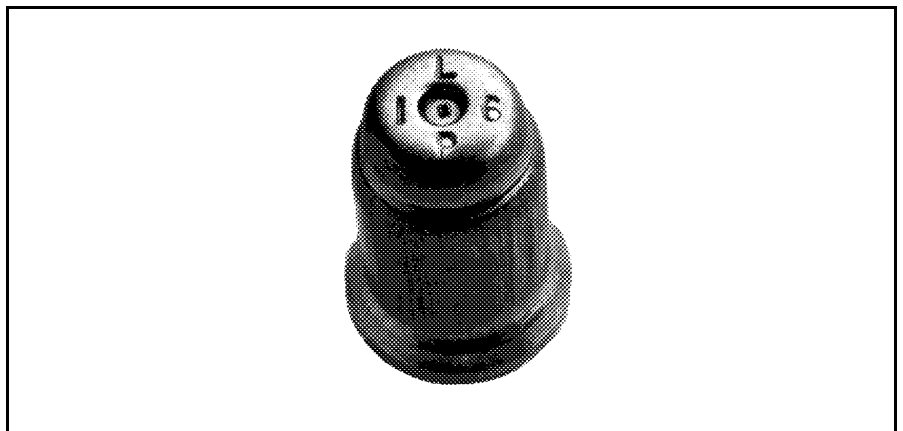

Figure 3.12A Orifice

Burner

Applies the correct amount of heat to the cooling unit, when it is supplied the correct amount of air and LP Gas.

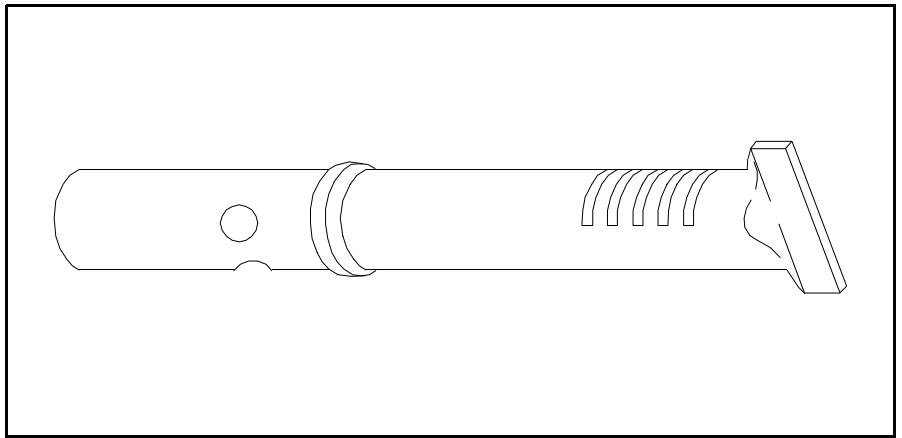

Figure 3.12B Burner

AC Heating Element

Applies the correct amount of heat to the cooling unit, when it is supplied with the correct AC voltage. All current 120 Volt AC heater will have black lead wires.

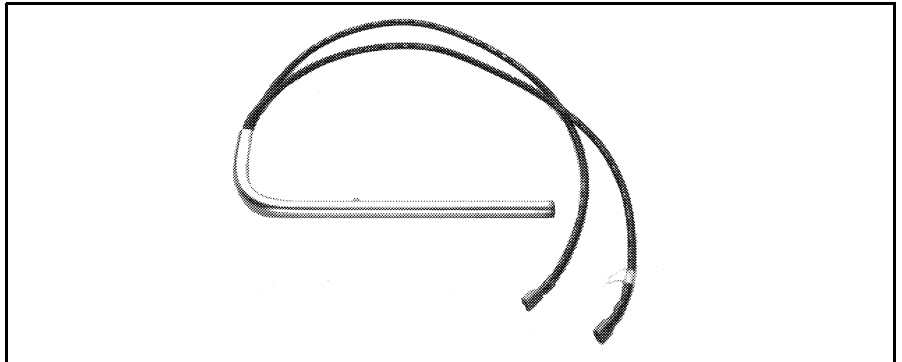

Figure 3.13 AC Heater

DC Heating Element

Applies the correct amount of heat to the cooling unit, when it is supplied with the correct DC voltage. All current DC heaters will have yellow lead wires indicating 12 Volts DC.

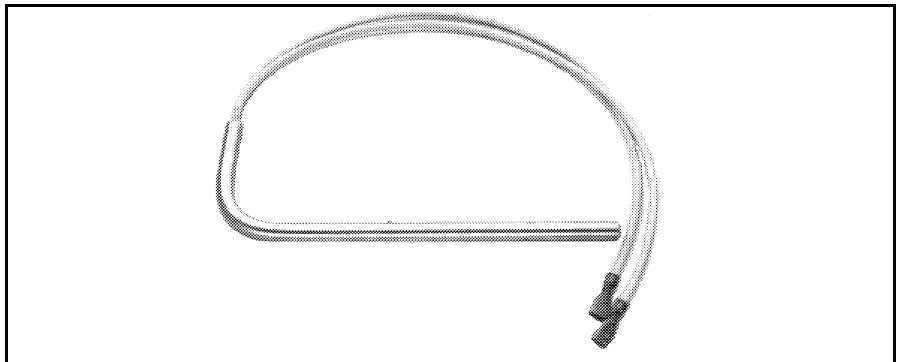

Figure 3.14 DC Heater

AC-DC Switch 3-Way Models Only

Selects the Electric mode (AC or DC operation). Also has an ELECTRIC-STANDBY position to temporarily shut off AC or DC operation.

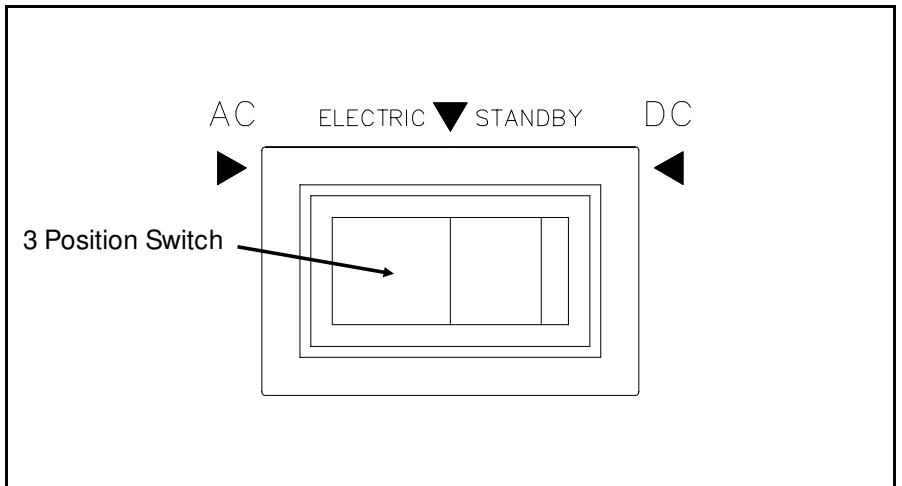

Figure 3.15 AC - DC Switch

Troubleshooting Procedures

Refrigerator Will Not Ignite Electrically on Propane

1. Check for 12 Volts DC between positive and negative leads at the rear of the refrigerator. If not present, correct source.

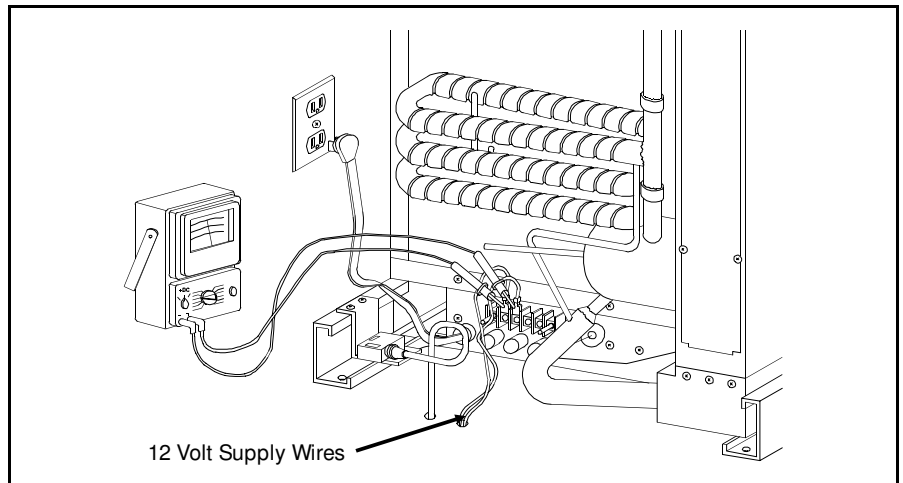

Figure 3.16 12 Volt Supply Check

2. If 12 Volts DC is present, then check the 3 Amp fuse for continuity. If open, then replace with fuse of same size and rating.

⚠ WARNING

NEVER OVERFUSE A CIRCUIT. REPLACE A BLOWN FUSE WITH EXACT REPLACEMENT INDICATED BY NORCOLD. OVERFUSING A CIRCUIT CAN CAUSE A FIRE.

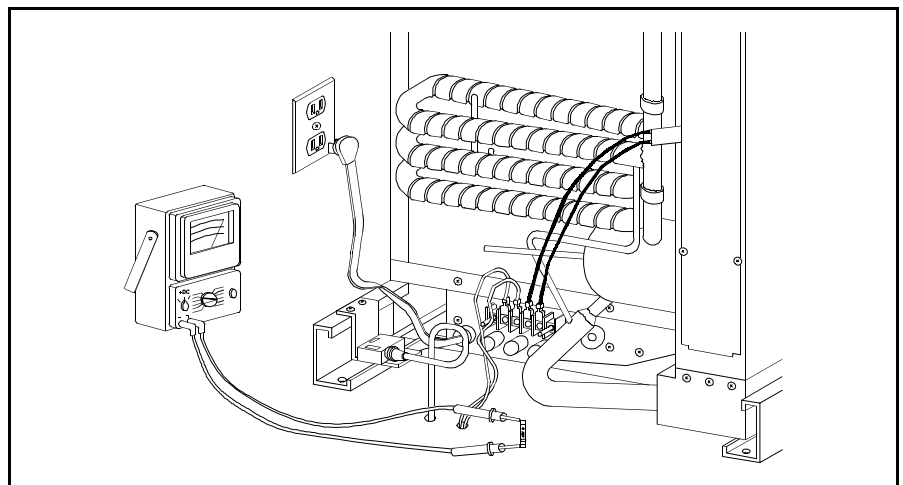

Figure 3.17 Fuse Continuity Check

3. If preceding checks did not reveal the cause of malfunction, then access to the control panel is required per Figure 3.18. The first step in gaining access is to remove the two control knobs (A), then remove the (6) Phillips head screws (B). Once the control panel has been removed, you need to remove the (2) Phillips head screws (C). Then pull the control mounting bracket forward. This allows access to the controls.

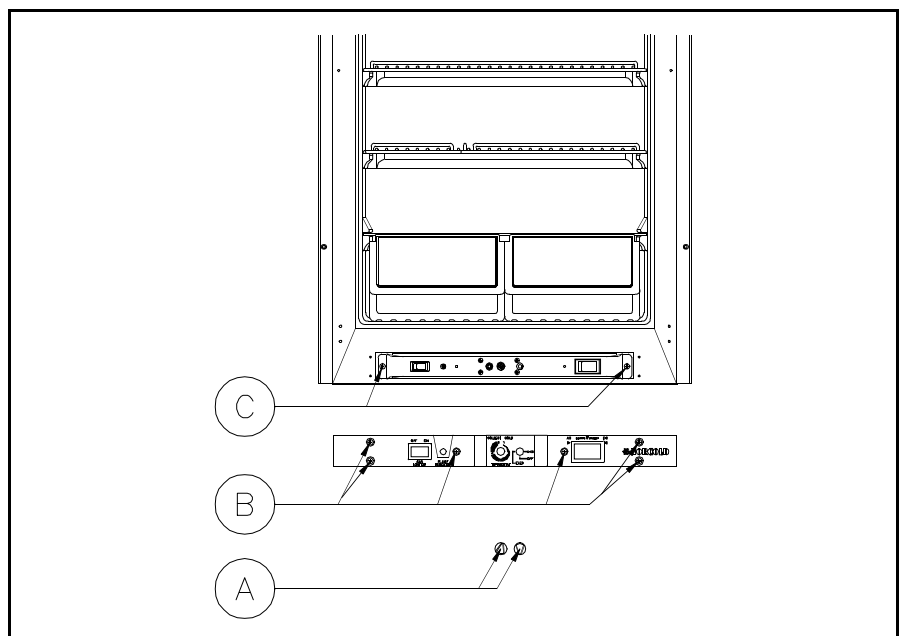

Figure 3.18 Controls Access

- To check for loose wire connections, set your Volt-Ohm meter to + 25 Volt scale. Check for presence of 12 volts at the Ignitor rocker switch from the center wire of the switch to DC negative, as shown in Figure 3.19. If present, proceed to Step 5.

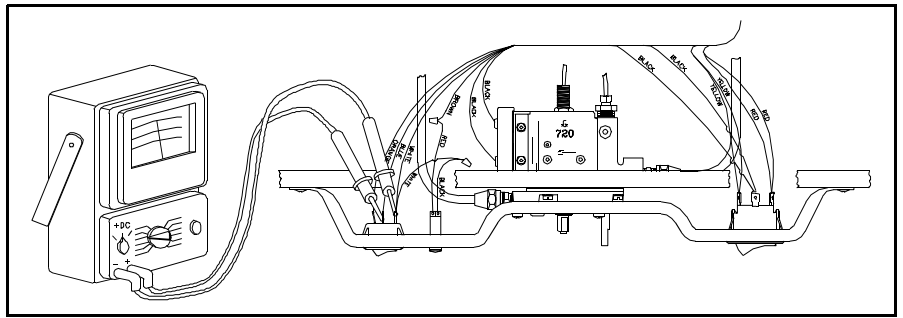

Figure 3.19 12 Volt Check at Blue and White Terminals

- Check for 12 volts at the outlet of the Ignitor switch, making sure the switch is on. If 12 volts is not present between the DC negative and outlet wire, as shown in Figure 3.20, replace the switch. If 12 Volts is present, then proceed to Step 6.

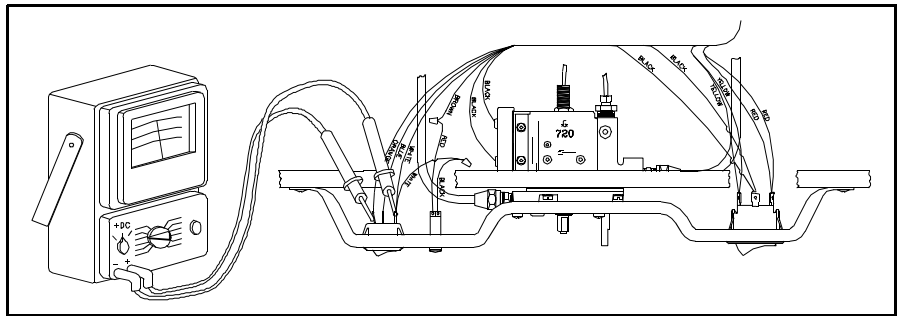

Figure 3.20 12 Volt Check at Orange and White Terminals

- Refer to Figure 3.21. Disconnect the spark wire. To gain access to the relighter, remove the 2 phillips head screws.

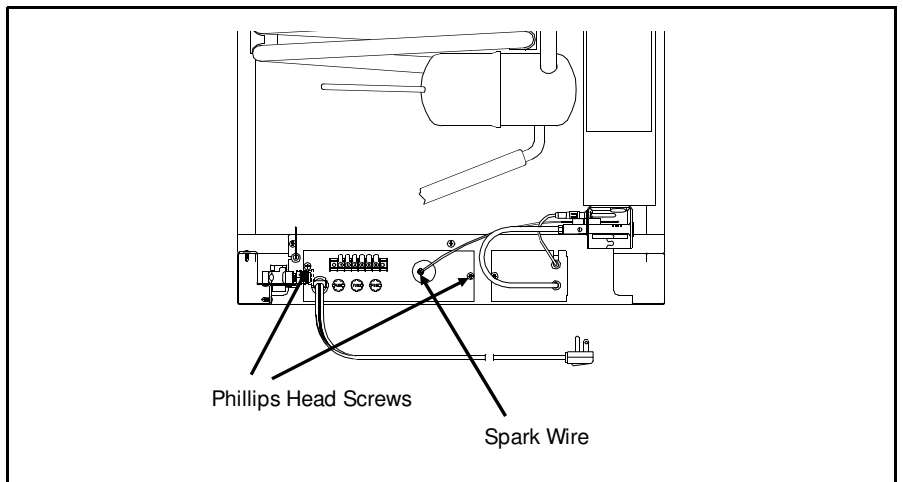

Figure 3.21 Relighter Access

- Then remove Phillips head screws which retain relighter in position as illustrated in Figure 3.22. Reconnect the spark wire.
- With VOM set to + DC 25 Volt scale, check for 12 Volts across + and - terminals. If present, but there is no spark, replace relighter.

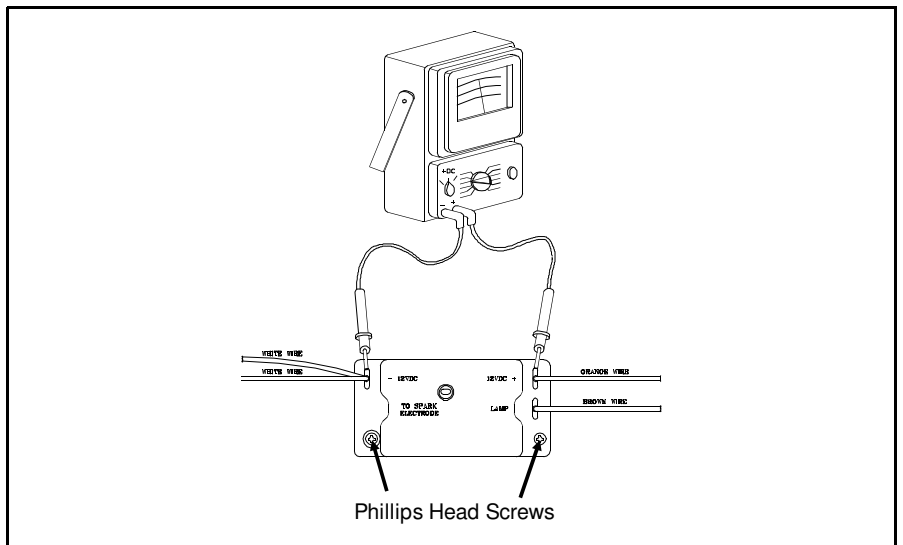

Figure 3.22 12 Volt Check at White and Orange Terminals

Refrigerator Indicates No Flame Established

If the Flame Indicator is not illuminated, yet the Ignitor switch is ON with 12 volts available to unit and flame at burner, then check the following:

1. Keep in mind that the Flame Indicator will not illuminate unless a flame has been established.
2. Set VOM to + 5 Volts scale. You should read from 1.5 to 2 Volts DC at the terminals of the Relighter shown in Figure 3.23. If not, replace the Relighter.
3. With the Ignitor Switch on, and a flame established, check first that the wires to the flame indicator bulb are not reversed. Properly wired would be: red lead from bulb to brown harness wire; black lead from bulb to white harness wire shown in Figure 3.24.
4. With test probes at points indicated in Figure 3.23, you should read on the 5 Volt DC scale something less than 2 Volts. If voltage is present and the Flame Indicator still does not illuminate, then replace Flame Indicator.

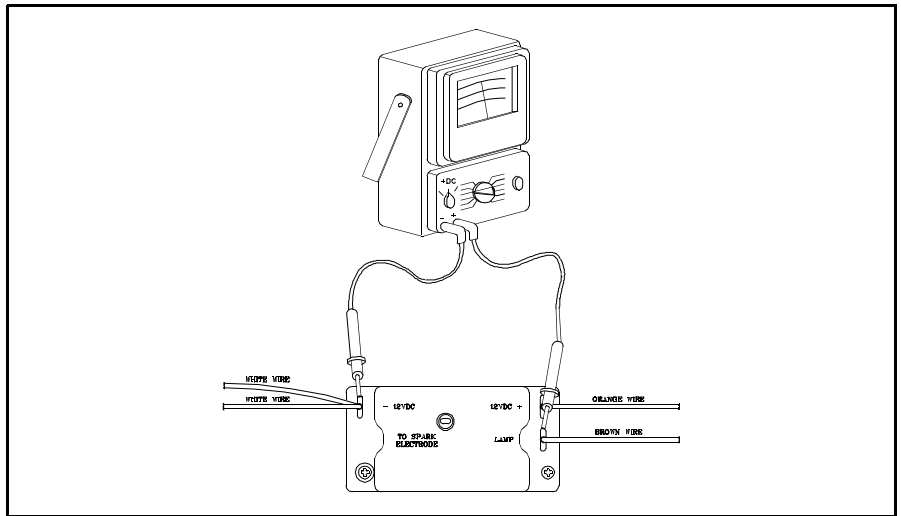

Figure 3.23 Flame Indicator Check at White and Brown Term.

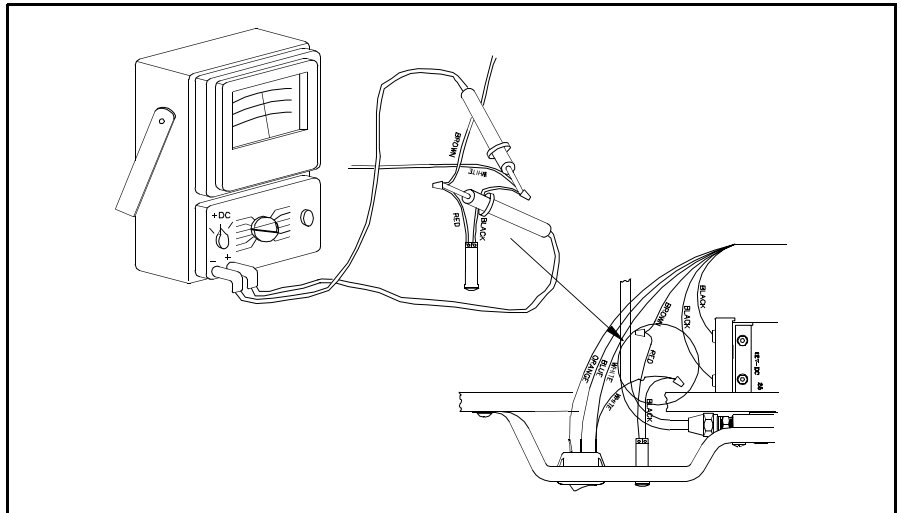

Figure 3.24 Flame Indicator Check

Flame will not stay lit (Lights and Then Goes Out)

1. Remove the control knob and depress the shaft with your finger until it bottoms out as shown in Figure 3.25. If refrigerator ignites and stays lit realign the combination control and reinstall knob. If ignition does not occur, proceed to next step.
2. When the burner ignites and then goes out, this can be caused by (1) thermocouple not positioned properly in the flame or (2) retaining clip not properly installed. See Figure 3.26.
3. Another check to perform would be to remove the control panel and control mounting bracket as shown in Figure 3.18. This will allow you to check the tightness of the thermocouple connection into the combination control as shown in Figure 3.27.
4. If the preceding steps fail to allow the refrigerator to ignite, the next check is the main line gas pressure to the refrigerator. See the section on Gas Pressure Checks.
5. If you read less than 11" water column pressure, then your main tank regulator must be adjusted.

WARNING

USE EXTREME CAUTION WHEN WORKING ON OR NEAR A PROPANE GAS SYSTEM. DO NOT SMOKE NEAR THE PROPANE GAS SYSTEM. DO NOT USE AN OPEN FLAME TO CHECK TO CHECK THE PROPANE SYSTEM FOR LEAKS. A LOOSE PROPANE SUPPLY LINE CONNECTION ALLOWS GAS VAPORS TO ESCAPE. IF YOU CAN SMELL FUMES, YOU HAVE HALF THE INGREDIENTS FOR AN EXPLOSION. AN EXPLOSION CAN RESULT IN A SEVERE PERSONAL INJURY OR DEATH.

6. Check the gas pressure through the Combination Control. Figure 3.28 shows where the "U" tube is to be connected.

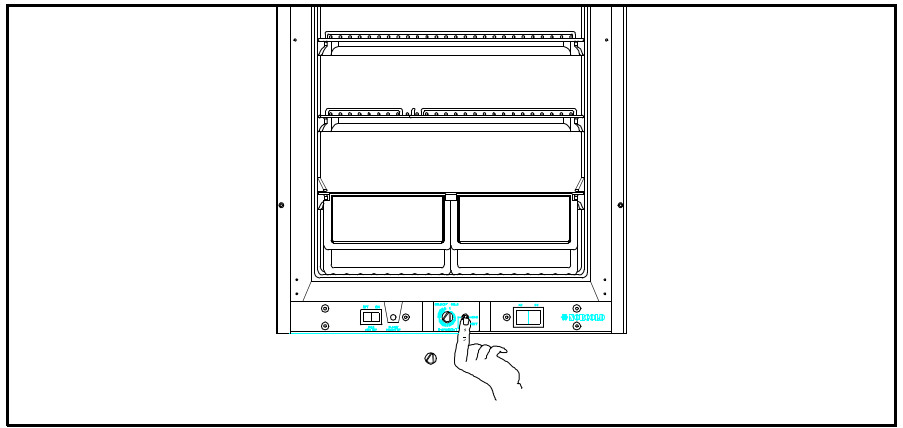

Figure 3.25 Depressing Safety Valve Shaft

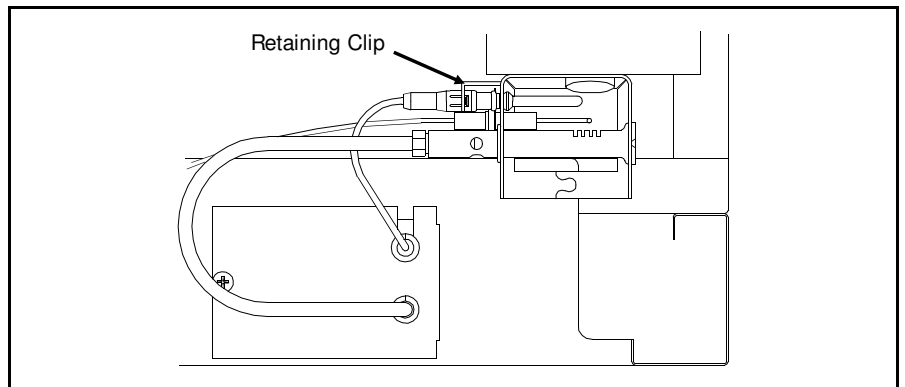

Figure 3.26 Thermocouple in Proper Position

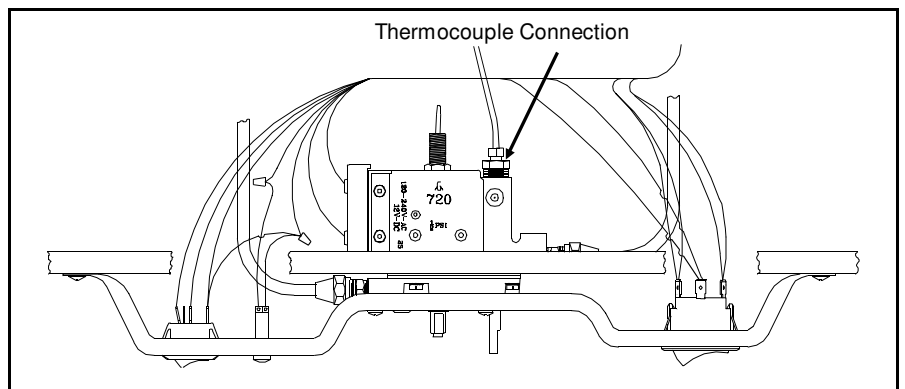

Figure 3.27 Thermocouple Connection

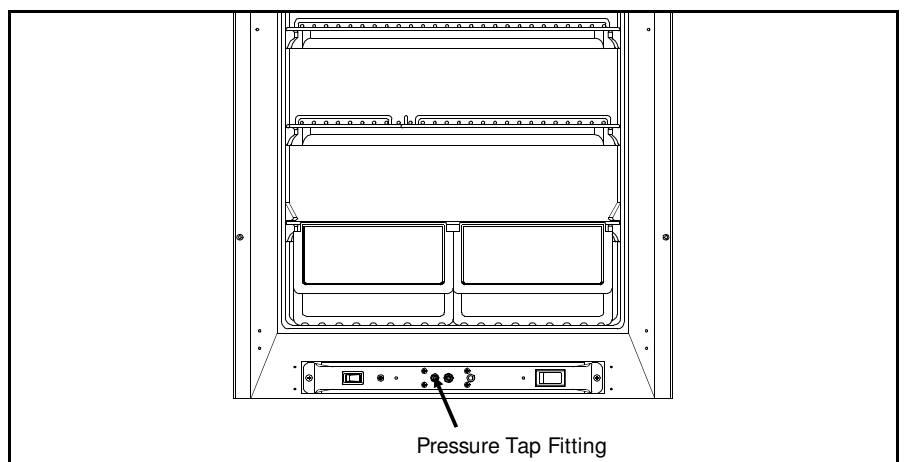

Figure 3.28 Location of Pressure Tap Fitting

7. The adjacent chart specifies the maximum pressure (high fire) and minimum pressure (low fire) for the burner operation. The Combination Control modulates the pressure to the burner between this minimum/maximum range based on ambient temperature, refrigerator load, and thermostat setting.
8. Access to the combination control is gained by removing (2) knobs and (6) screws as shown in Figure 3.18. The Combination Control needs not be removed for the pressure check.
9. Use a 3/16" allen wrench to remove the plug and a 1/8" NPT nipple to install in pressure tap fitting.

**Gas Pressure Settings For Refrigerator
(Inlet Gas Pressure at 11" W.C.)**

Model	High Fire	Low Fire
442, 443	10.5" To 10.9" W.C.	1.2" To 2.4" W.C.
452, 453	10.5" To 10.9" W.C.	1.2" To 2.4" W.C.
462, 463	10.5" To 10.9" W.C.	.8" To 1.8" W.C.
482, 483	10.5" To 10.9" W.C.	.8" To 1.8" W.C.

See Step # 7 for proper operation of combination control

10. Figure 3.29A represents a possible defective combination control, a clogged gas filter or a kinked supply line. Figure 3.29B indicates proper gas pressure in a properly functioning refrigerator.

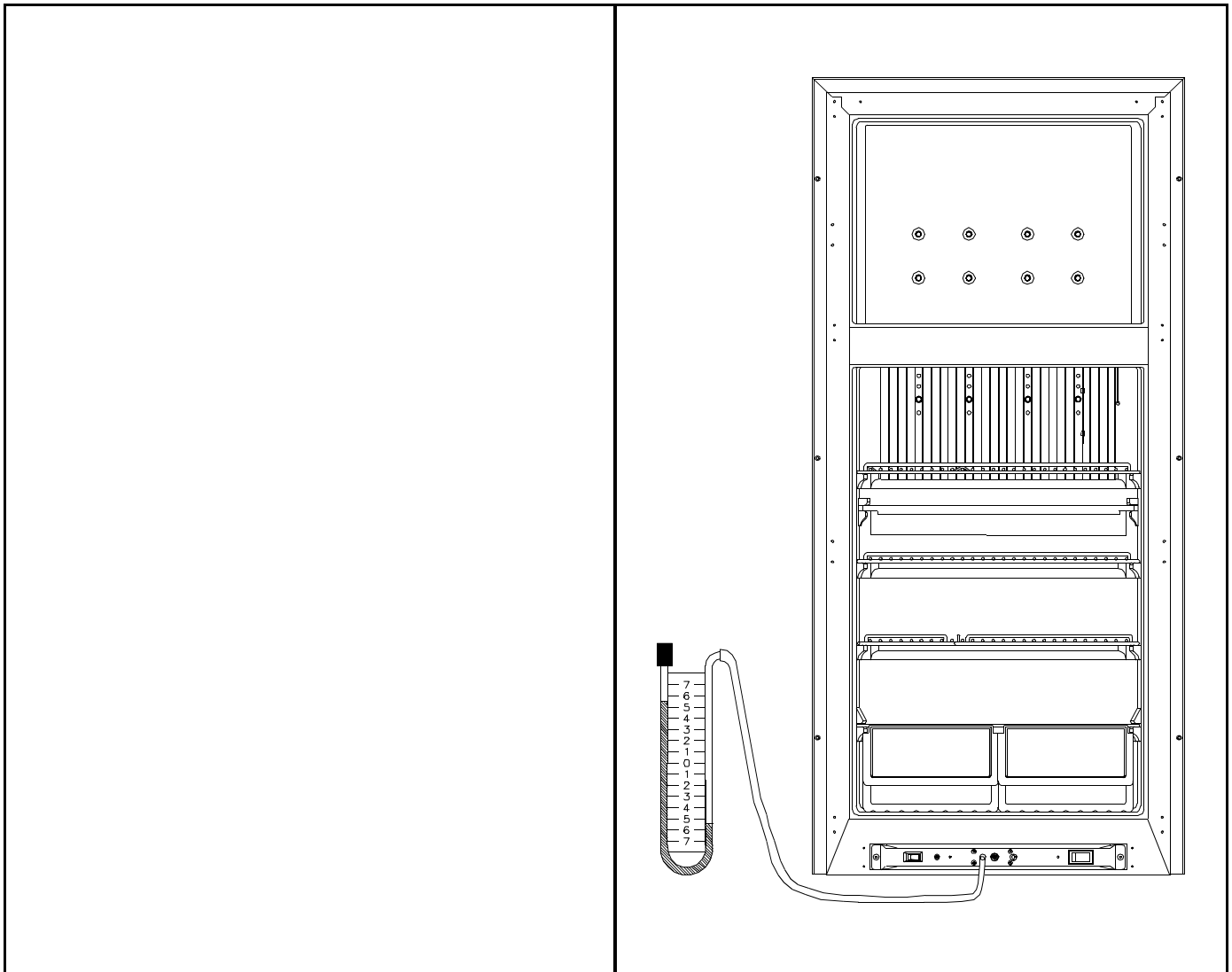

Figure 3.29A Incorrect Manometer Reading
(warm refrigerator)

Figure 3.29B Correct Manometer Reading

Refrigerator Overfreezing

1. With gas supply off, hook up your U-tube or gas manometer as shown.
2. A part which can cause this symptom is the combination control.
3. Remove the capillary tube from the fins. Place a cup of ice water on the top shelf of the refrigerator. Immerse the capillary tube in the ice water as shown in Figure 3.30.
4. If the pressure readings are not within the specifications as shown in the Gas Pressure chart, replace the combination control.
5. Another possible cause for overfreezing is that the capillary tube is not properly attached to the evaporator fins.
6. The capillary tube must be attached to the 5th fin as shown in Figure 3.31.

The Refrigerator Will Not Operate or Cool on AC

⚠ WARNING

USE EXTREME CAUTION WHEN WORKING ON THE AC ELECTRICAL COMPONENTS OF THE REFRIGERATOR. BEFORE REPLACING ANY ELECTRICAL COMPONENTS, DISCONNECT THE AC POWER SOURCE TO THE REFRIGERATOR. ELECTRICAL VOLTAGE CAN CAUSE SEVERE INJURY OR DEATH.

1. If the refrigerator is not functioning on AC, the first step is to check incoming supply voltages as shown in Figure 3.32. The minimum is 108 Volts AC.
2. Once you have established a good AC supply voltage, then remove the 5 Amp fuse and check for continuity as shown in Figure 3.33. If reading is good, reinstall fuse and proceed to next step.

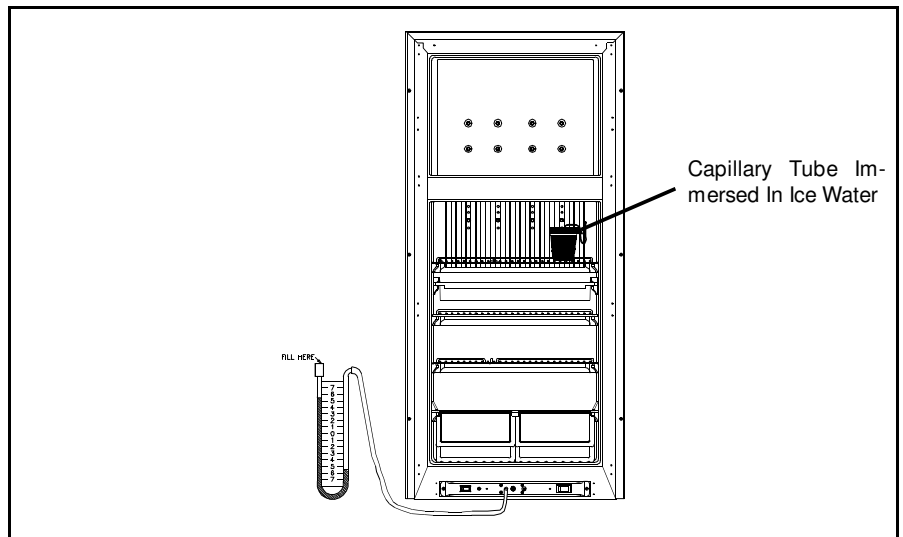

Figure 3.30 Check for Overfreezing

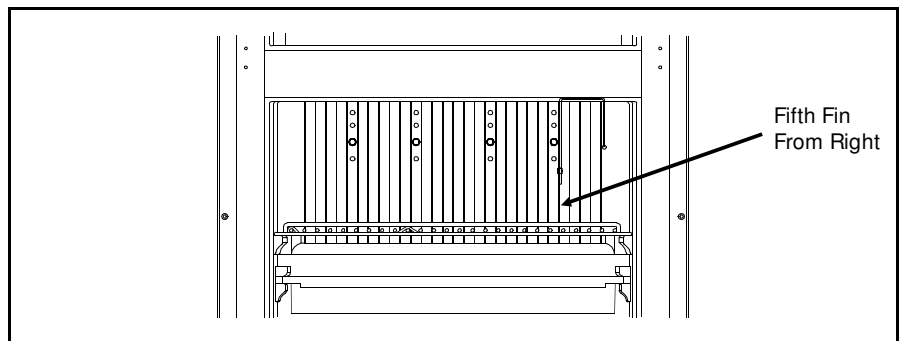

Figure 3.31 Capillary Tube Location

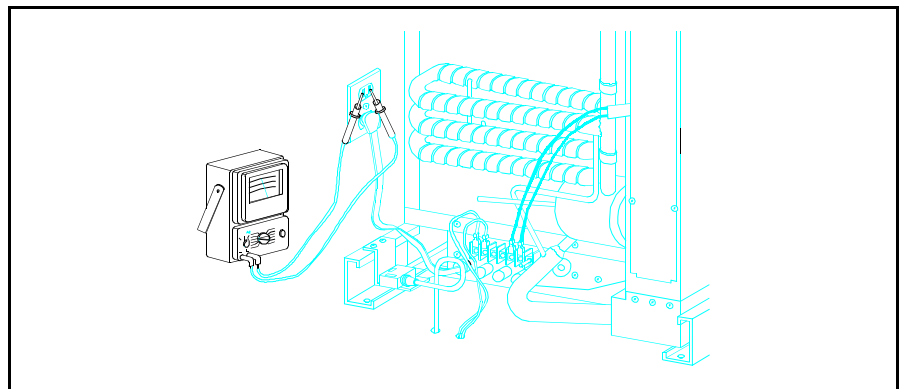

Figure 3.32 Check for AC Supply Voltage

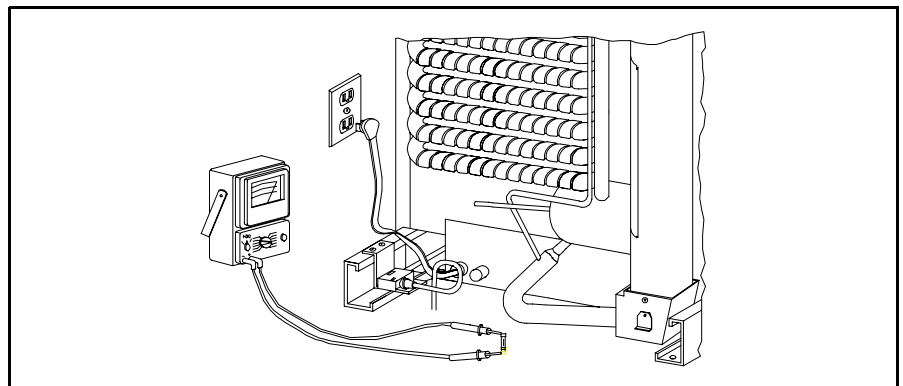

Figure 3.33 Checking F1 Fuse for Continuity

⚠ WARNING

NEVER OVERFUSE A CIRCUIT. REPLACE BLOWN FUSE WITH EXACT REPLACEMENT INDICATED BY NORCOLD. OVERFUSING OF A CIRCUIT CAN RESULT IN A FIRE.

Note: Before gaining access to the combination control, check the AC Heater element as described in Steps 14-18 on pages 3-17 & 3-18.

3. We must now gain access to the AC-ELEC STDBY-DC switch. This procedure only applies to 3-way models. On 2-Way models proceed to Step 8. Remove the two knobs (A) and the (6) Phillips head screws (B) from the control assembly as shown in Figure 3.34.
4. Remove the (2) Phillips head screws as shown (C) and pull the control mounting bracket forward.
5. Set AC-ELEC STDBY-DC switch to ELEC STDBY (not AC). With a Volt-Ohm meter, check for 120 Volts AC at Point 1 shown in Figure 3.35. Then check Point 2. One test point should read 120 Volts and the other should read 0 Volts (the point which reads 120 Volts is the switch input terminal). This confirms voltage to the switch. If neither test point reads 120 Volts, check for bad connections.
6. Set AC-ELEC STDBY-DC switch to AC; Mode Selector to ELEC; Thermostat to COLDEST.
7. Check for 120 Volts at Point 1 and ground and Point 2 and ground of switch as shown in Figure 3.36. Normal readings should show 120 Volts on both terminals. If 0 Volts are read, check wiring connections.

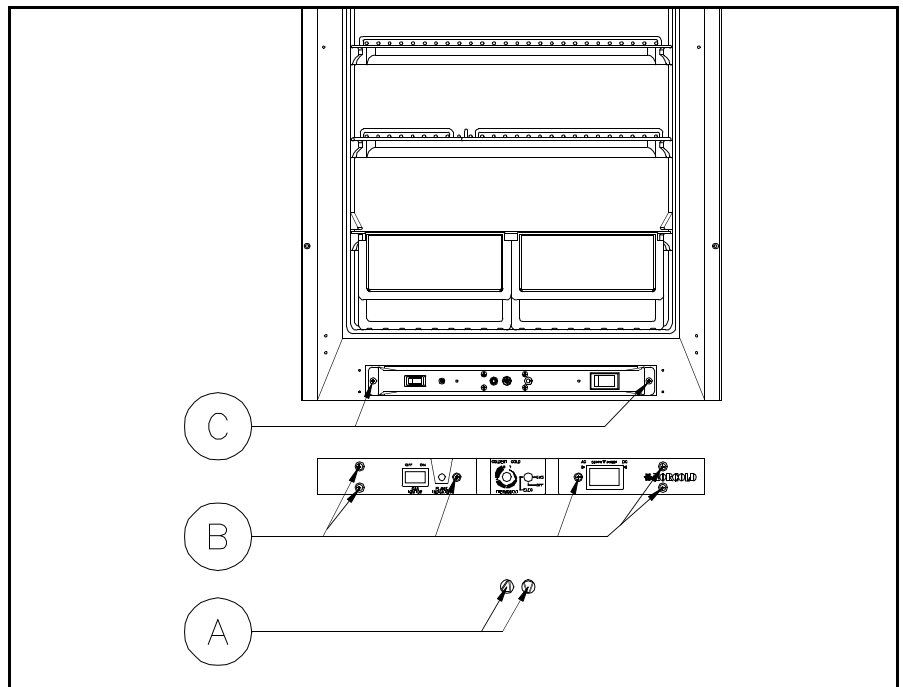

Figure 3.34 Access to Controls

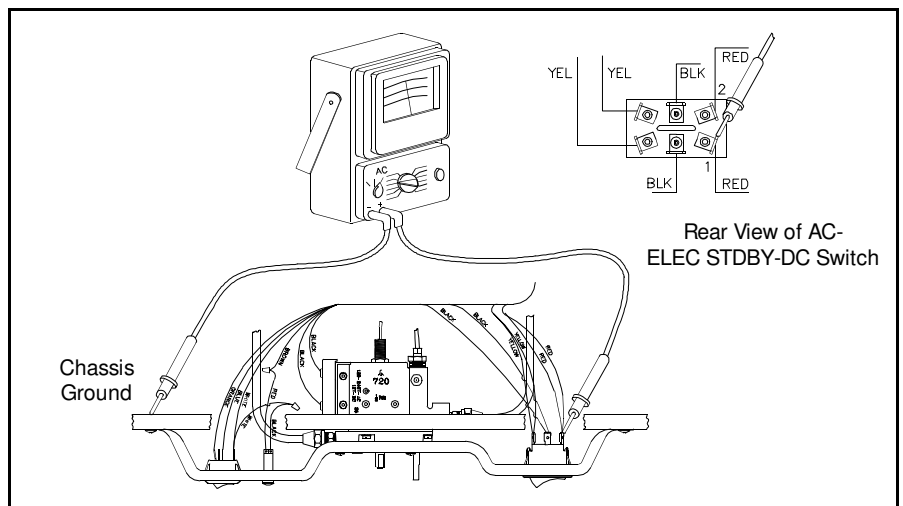

Figure 3.35 120 Volt Check at Switch Inlet

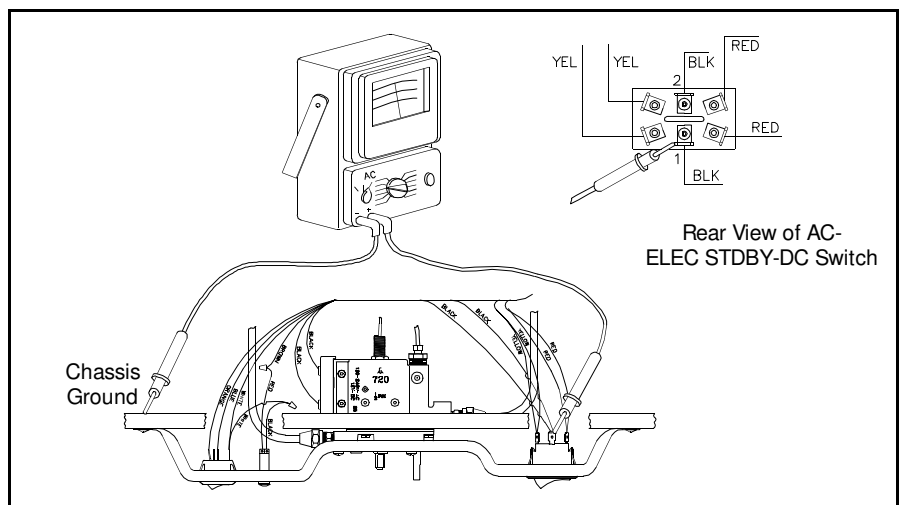

Figure 3.36 120 Volt Check at Switch's Center Contacts

8. Check for 120 Volts at each terminal to ground of the combination control as illustrated in Figures 3.37 and 3.38. Normal readings should show 120 Volts on both terminals.
9. If there is 0 Volts on both terminals, check wiring connections. If there is 120 Volts on only one terminal, replace the Combination Control. If unit is a 2-Way, skip to Step 12.
10. Check for 120 Volts at Point 1 and ground and Point 2 and ground of switch as shown in Figure 3.35 (AC-ELEC STDBY-DC switch is now set at AC).
11. There should be 120 Volts at both Points 1 and 2. If not, and connections are checked as proper, replace AC-ELEC STDBY-DC switch.

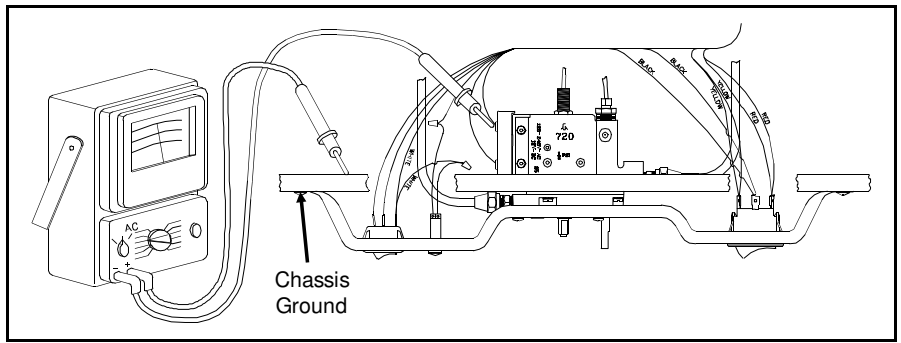

Figure 3.37 120 Volt Check of Combination Control Switch

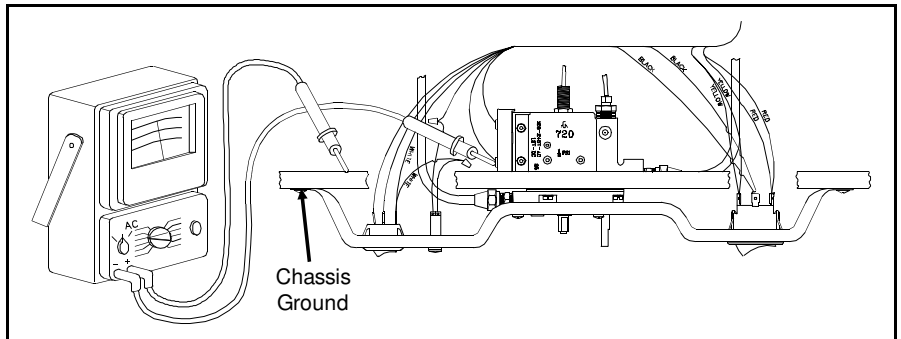

Figure 3.38 120 Volt Check of Combination Control Switch

12. Check for 120 Volts AC at your heater element connection as shown in Figure 3.39.
13. If no voltage is present and the preceding checks have been made, then most likely there is a loose wire connection between the combination control and the heater element connection at terminal block.
14. The last check to make is for continuity on AC heater element leads as shown in Figure 3.40.
15. With the Volt-Ohm meter set to the Rx1 scale, check the resistance of the heater (Figure 3.40 A). The resistance should be as shown:

170W*	71 OHMS
300W	41 OHMS
200W	61 OHMS

These readings are acceptable + or - 5%

Set volt-ohm meter to the Rx10 scale or higher and check the heater element for a short to ground. The meter should show no movement.

* Early Version

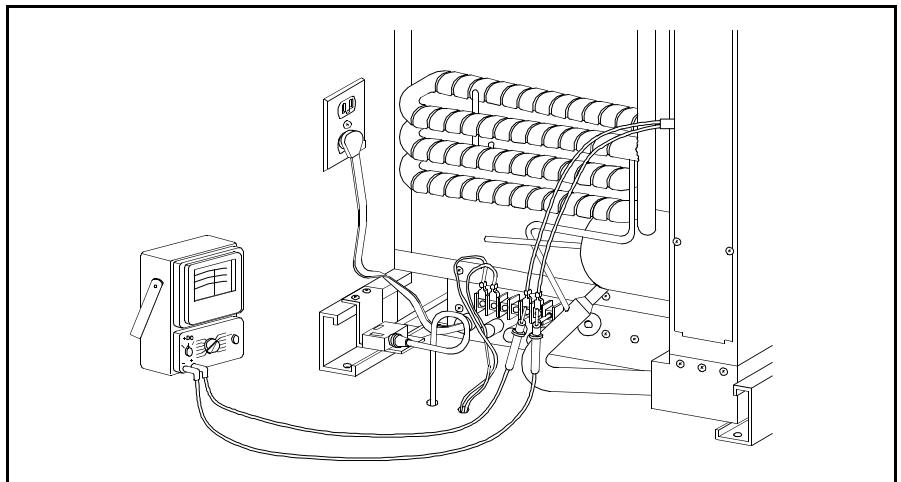

Figure 3.39 120 Volt Check at Heater Connections

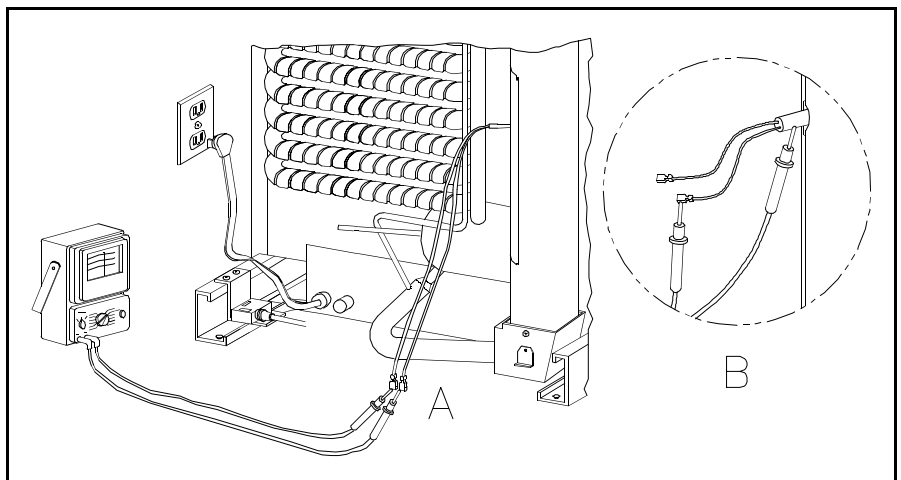

Figure 3.40 Heater Resistance Check

16. If you read an open, the refrigerator will not cool and the heater element must be replaced.
17. If you have a reading, but it is less or greater than the specification, it indicates the element is not the correct size and must be replaced.
18. A shorted heater element will cause the 5 Amp fuse to blow.

The Refrigerator will not Operate or Cool on DC Electric

Note:

DC operation will not initially cool down the refrigerator. The initial cooling must be done in either the GAS or AC modes. Attempting to cool down the refrigerator in the DC mode will result in poor cooling or battery run down.

1. Check for 12VDC between positive and negative leads at the rear of the refrigerator as shown in Figure 3.41.
2. The voltage must be from 10.5 to 15.4 volts with the refrigerator on.
3. Check the continuity of F3 fuse. Figure 3.42 indicates a blown fuse (meter pointer remained at left side of scale. If the fuse was good, the meter pointer would have been to the right side of the scale).
4. Replace the fuse if necessary. 15 Amp Fuse required on single door models and 20 Amps on double door models.

⚠ WARNING

NEVER OVERFUSE A CIRCUIT. REPLACE BLOWN FUSE WITH EXACT REPLACEMENT INDICATED BY NORCOLD. OVERFUSING A CIRCUIT CAN RESULT IN A FIRE.

Note: Before gaining access to the combination control, check the DC Heater element as described in Steps 16-19 on page 3-20.

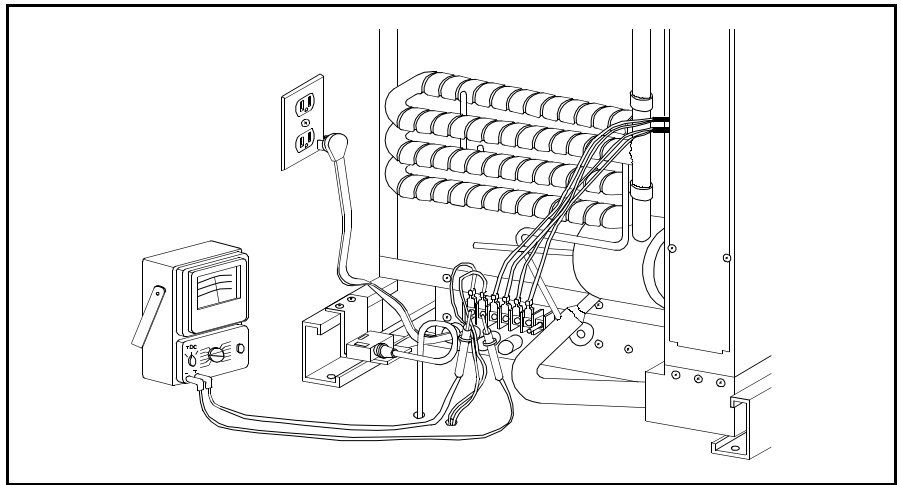

Figure 3.41 12 Volt Check at DC Supply Connections

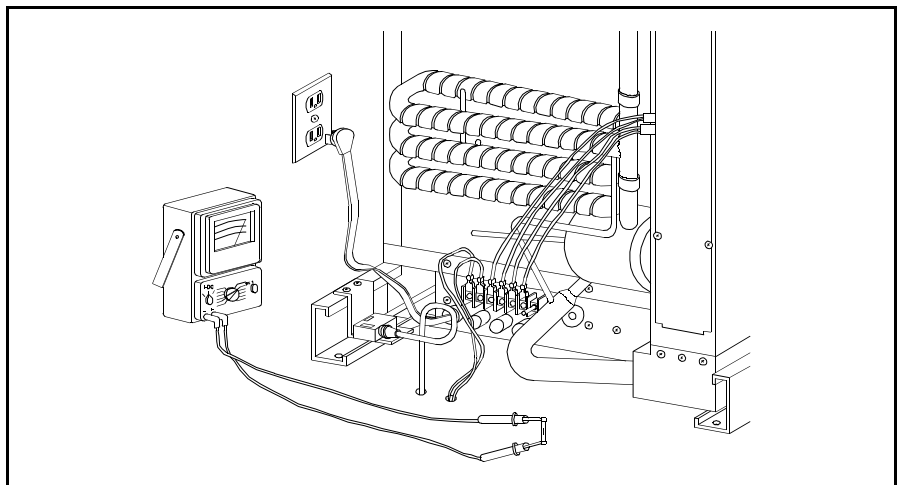

Figure 3.42 Checking F3 Fuse for Continuity

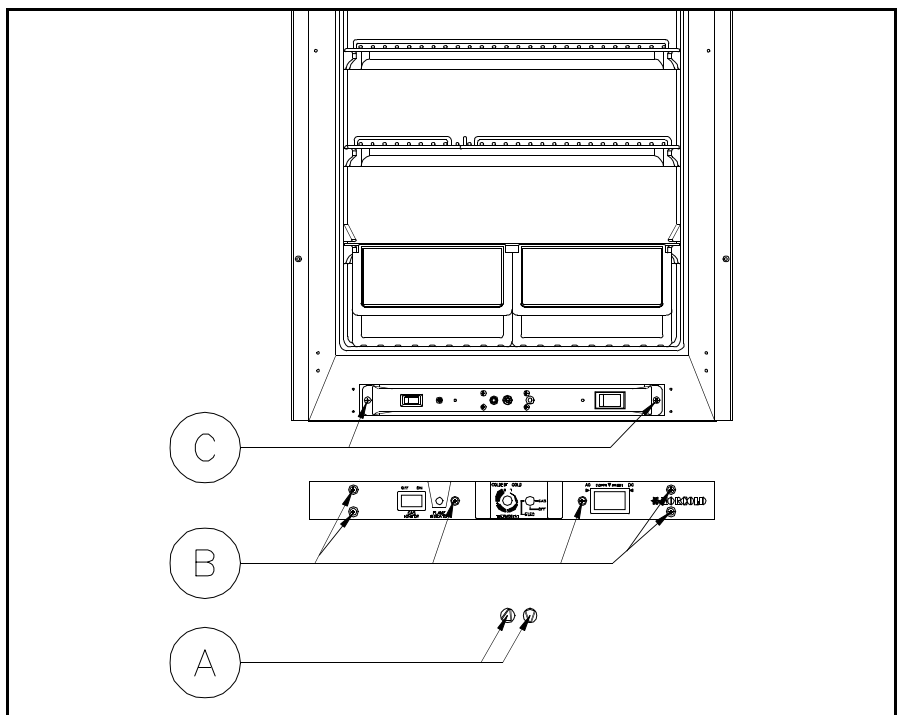

Figure 3.43 Access to Controls

5. If preceding checks did not reveal the cause of malfunction, then access to the control panel is required as shown in Figure 3.43. The first step in gaining access is to remove the two control knobs (A), then remove the (6) Phillips head screws (B) as shown. Once control panel has been removed, you need to remove (2) Phillips head screws (C). Then pull the control mounting bracket forward. This allows access to the controls.

6. Step 6, 7 & 8 apply to 3-Way units only. If you are checking a 2-Way skip to Step 9. Set AC-ELEC STDBY-DC switch to ELEC STDBY (not DC). With a Volt-Ohm meter, check for 12 Volts DC between Point 1 and ground shown in Figure 3.44. Then check Point 2. One test point should read 12 Volts and the other should read 0 Volts (the point which reads 12 Volts is the switch input terminal). This confirms voltage to the switch. If neither test point reads 12 Volts, check for bad connections.

7. Set AC-ELEC STDBY-DC switch to DC; Mode Selector to ELEC; Thermostat to COLDEST.

8. Check for 12 Volts at Point 1 and ground and Point 2 and ground at switch as shown in Figure 3.45. Normal readings should show 12 Volts on both terminals. If 0 Volts are read, check wiring connections.

9. With AC-ELEC STDBY-DC switch to DC; Mode Selector to ELEC; Thermostat to COLD-EST, check for 12 Volts at each terminal of the combination control and ground as illustrated in Figures 3.46 and 3.47. Normal readings should show 12 Volts on both terminals.

10. If there is 0 Volts on both terminals, check wiring connections. If there is 12 Volts on only one terminal, replace the Combination Control. If unit is

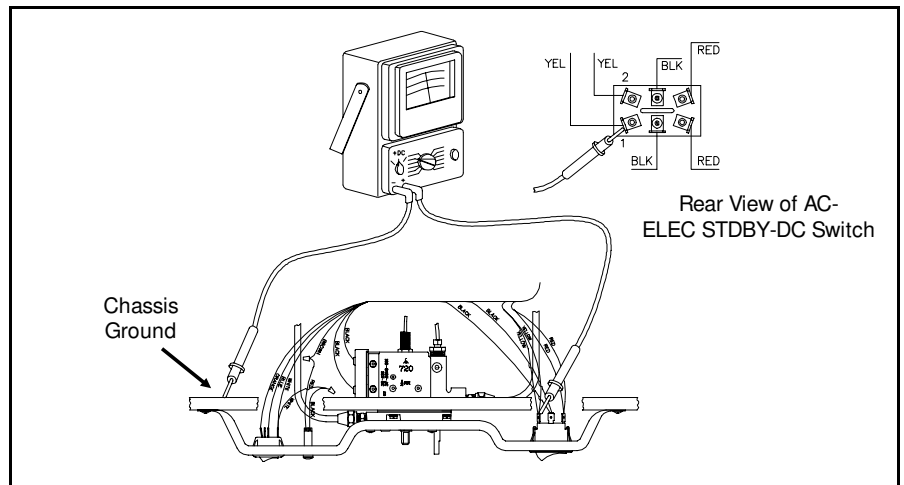

Figure 3.44 12 Volt Check at Switch Inlet

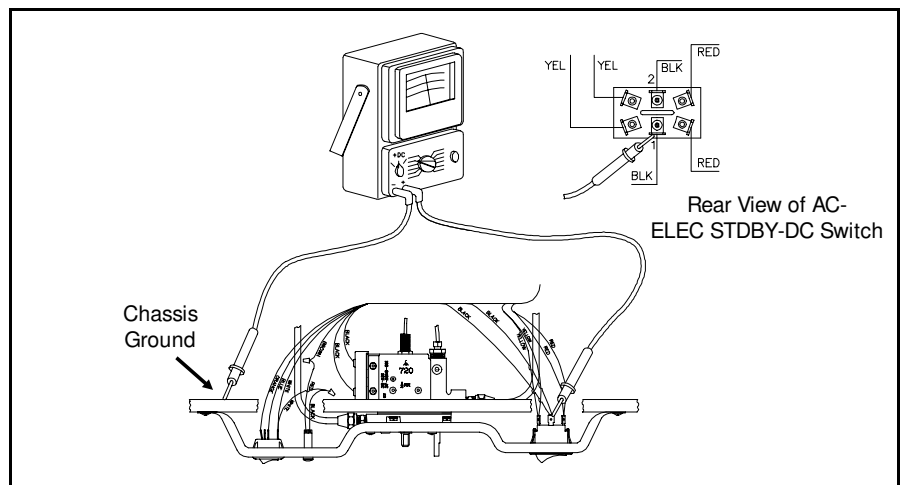

Figure 3.45 12 Volt Check at Switch's Center Contacts

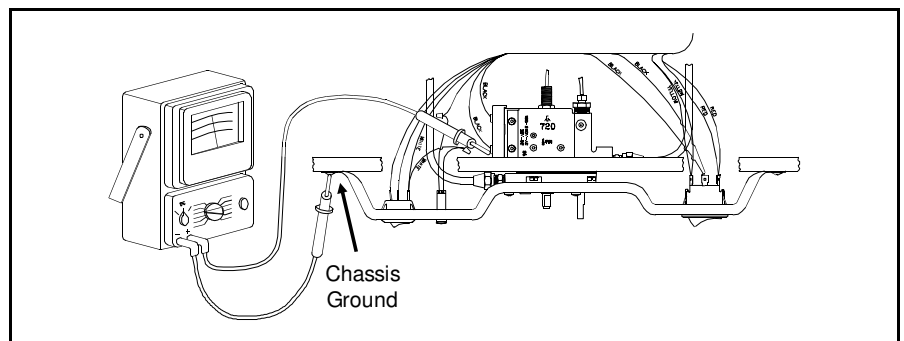

Figure 3.46 12 Volt Check at Combination Control

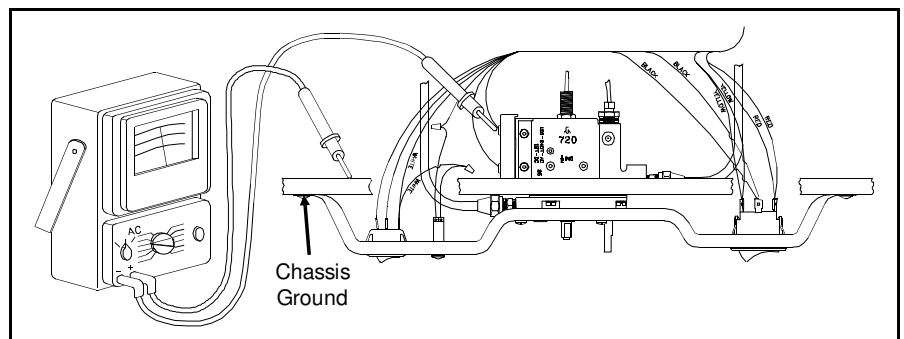

Figure 3.47 12 Volt Check at Combination Control Switch

a 2-Way, skip to Step 13.

11. Check for 12 Volts at Points 1 and 2 of switch and ground as shown in Figure 3.44 (AC-ELEC STDBY-DC switch is now set at DC).
12. There should be 12 Volts at both Points 1 and 2. If not, and connections are checked as proper, replace AC-ELEC STDBY-DC switch.
13. Check for 12 volts at the DC heater terminals as shown in Figure 3.48.
14. If there is no 12 volt reading, a bad connection is indicated between the thermostat and heater terminals.
15. If 12 volts is present, check the DC heater for continuity as shown in Figure 3.49.
16. Disconnect the DC heater leads from the terminals.
17. Set the Volt-Ohm meter to the Rx1 scale and measure the resistance of the DC heater with it at room temperature. The resistance should be as indicated below:

DC Element Resistance Reading

225 Watt	.8 OHMs
150 Watt	1.2 OHMs

Set volt-ohm meter to the Rx10 scale or higher and check the heater element for a short to ground. The meter should show no movement.

18. If the heater does not measure within $\pm 5\%$ of the indicated value, it must be replaced.
19. A shorted heater will cause the DC fuse to blow.

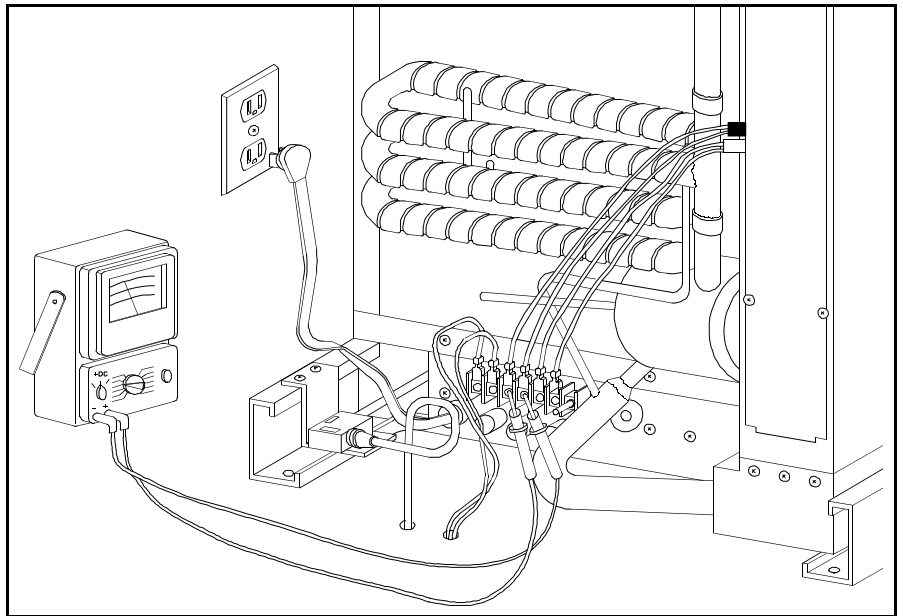

Figure 3.48

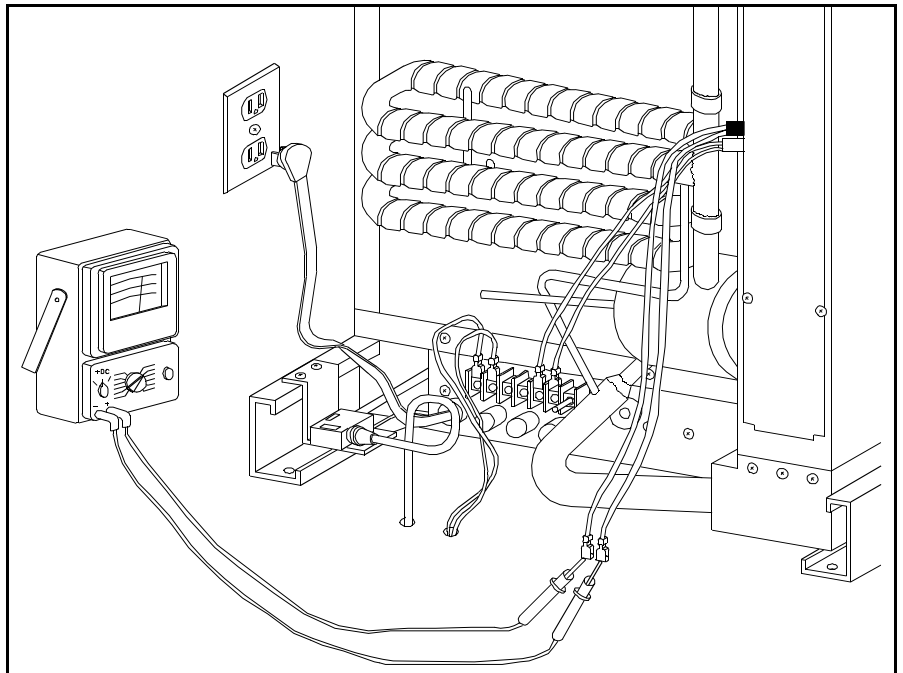
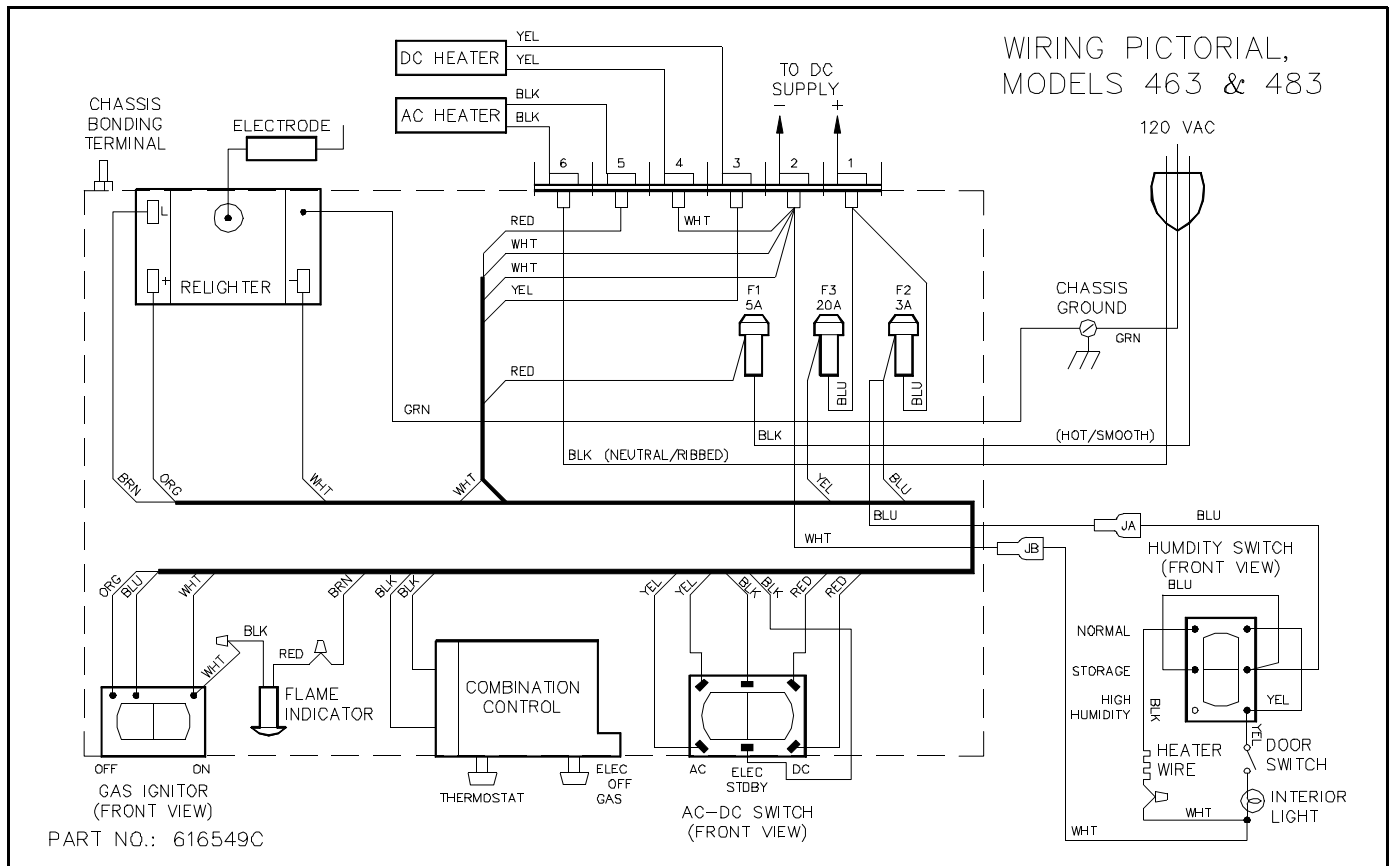
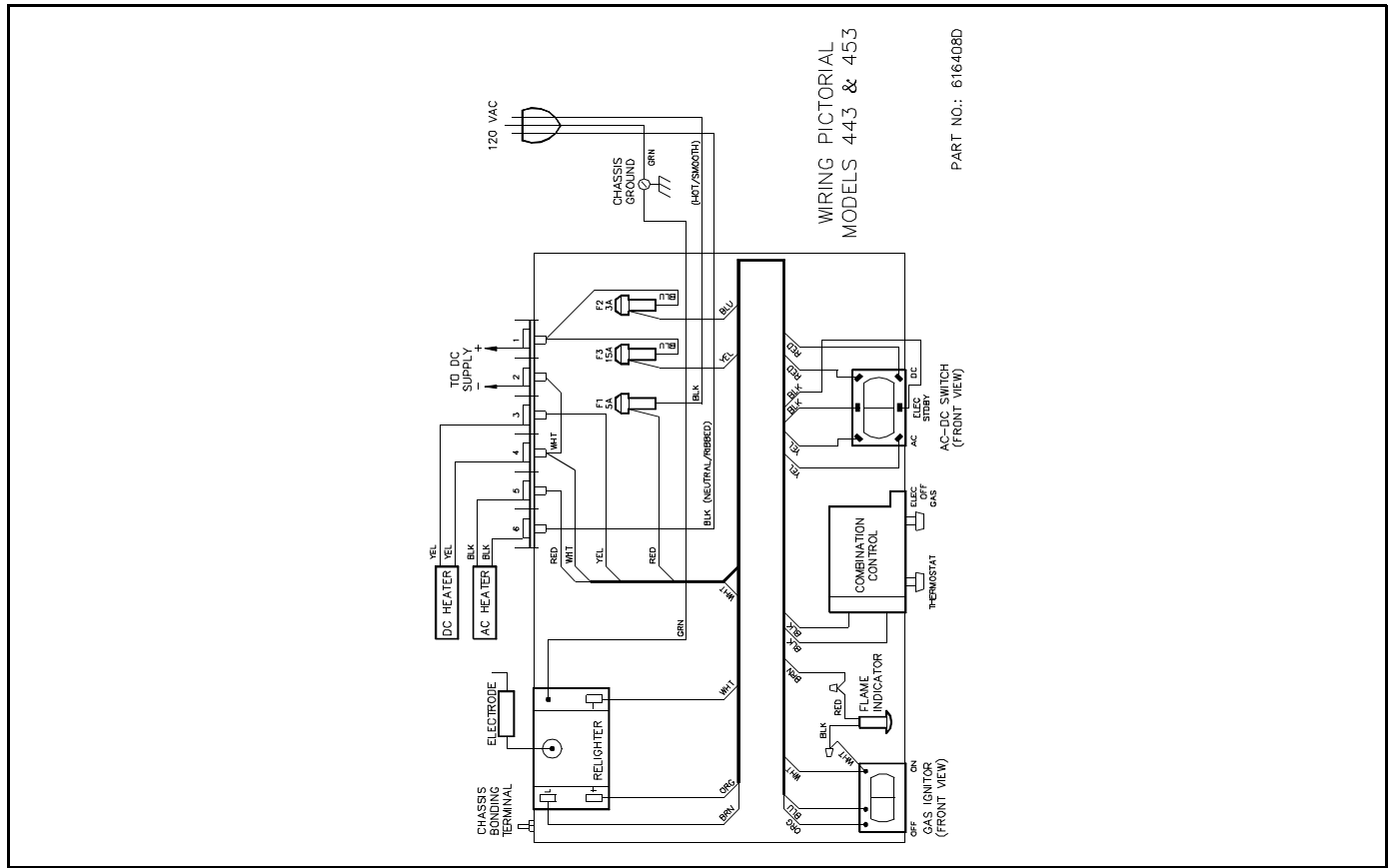
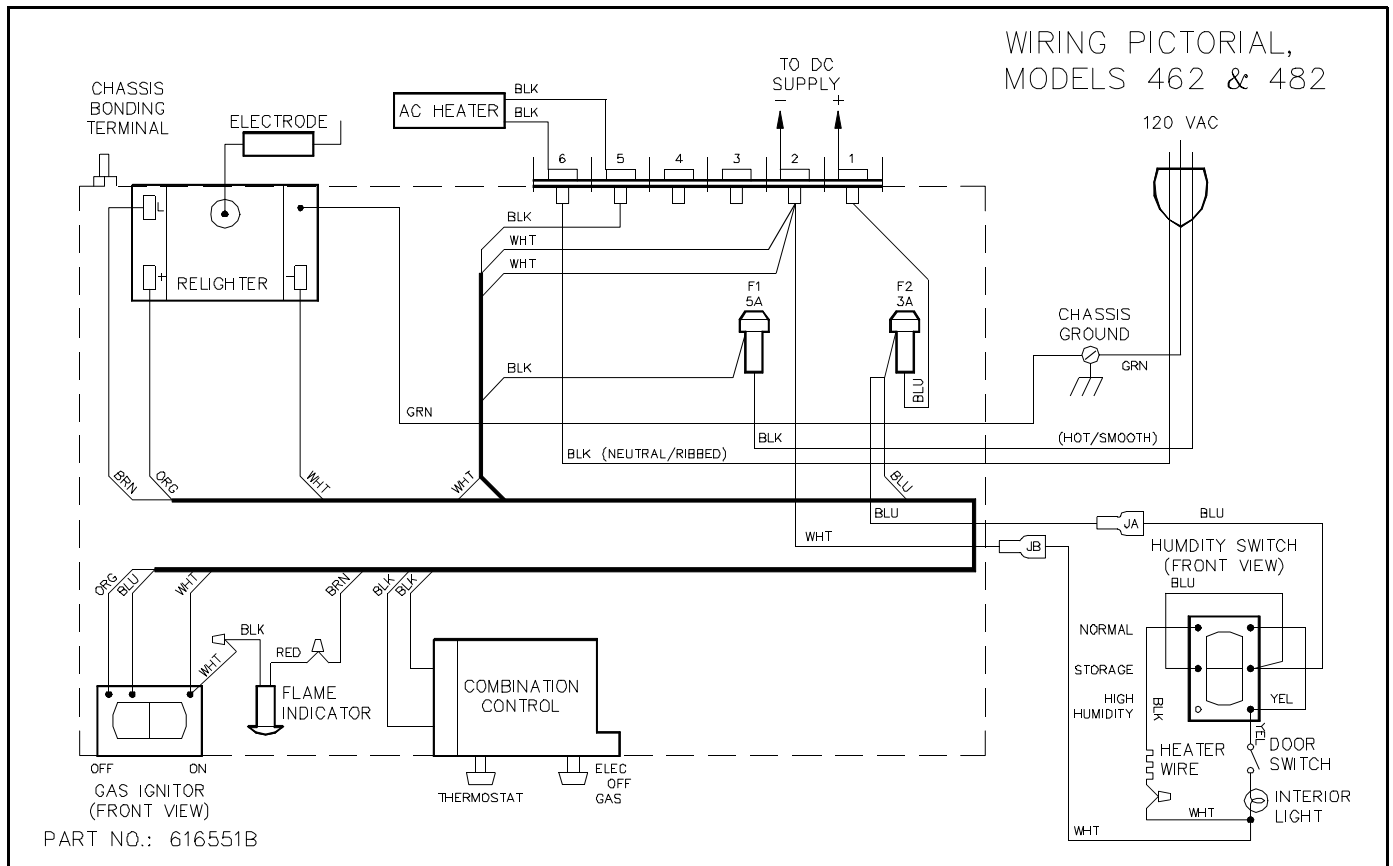
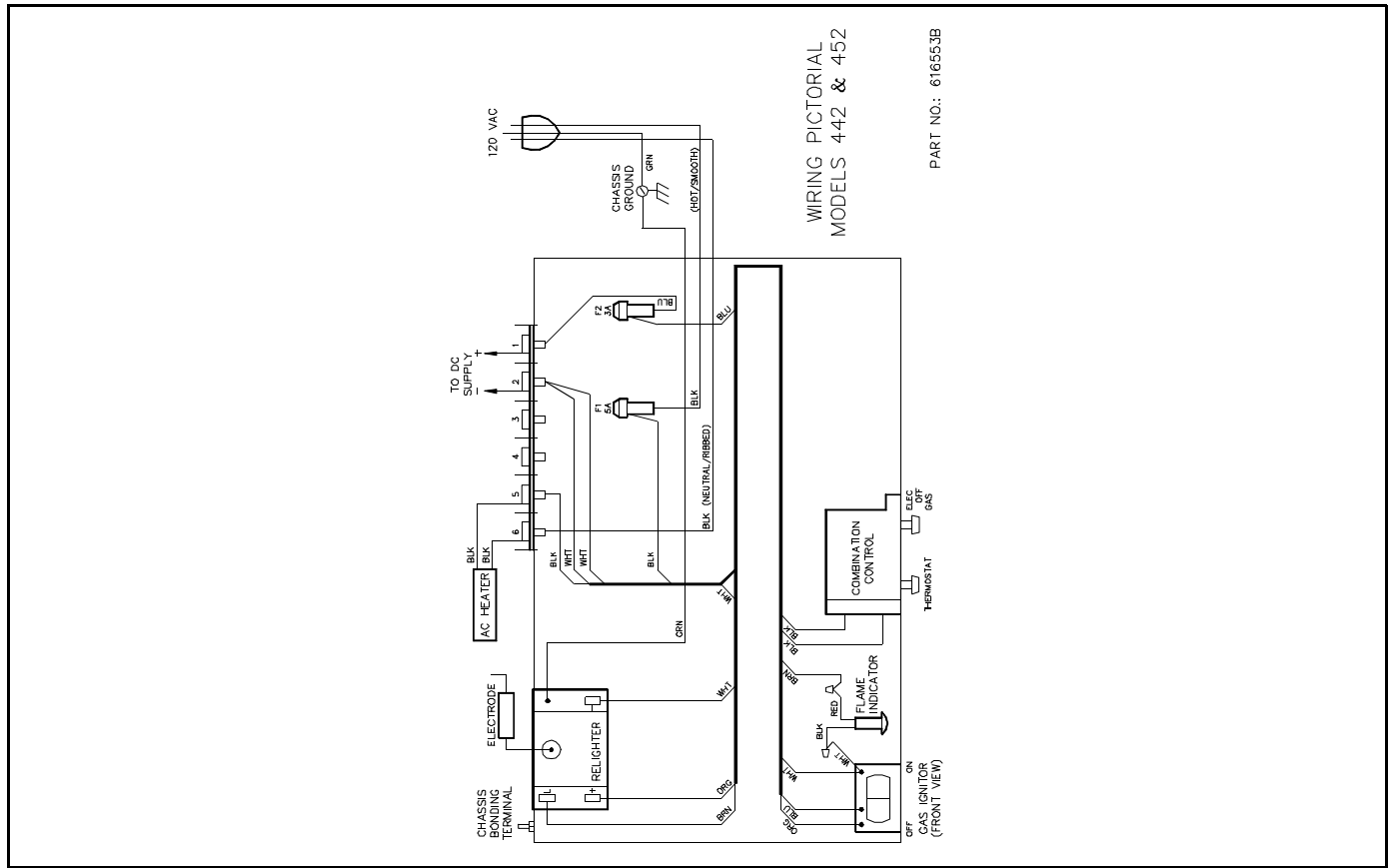
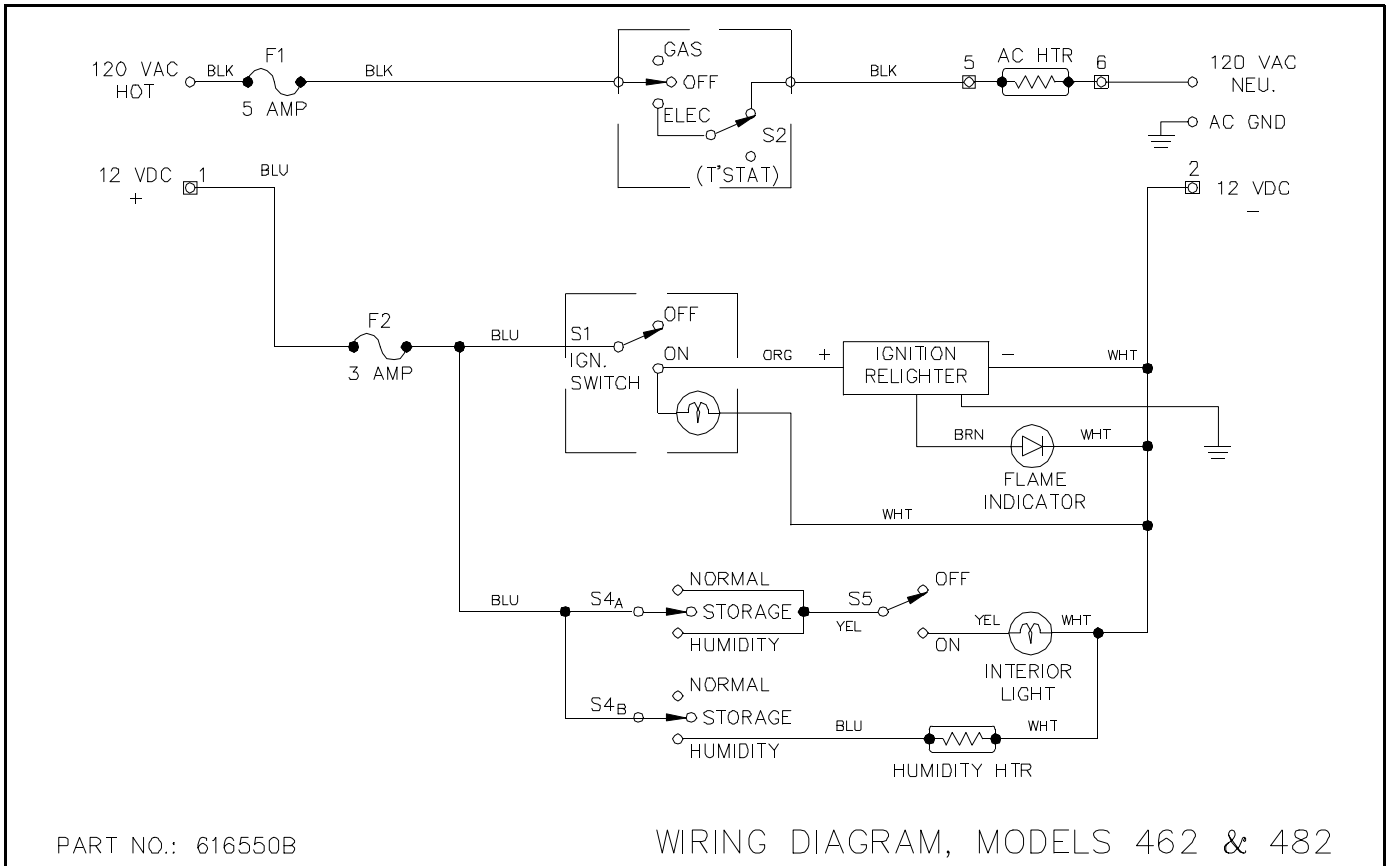
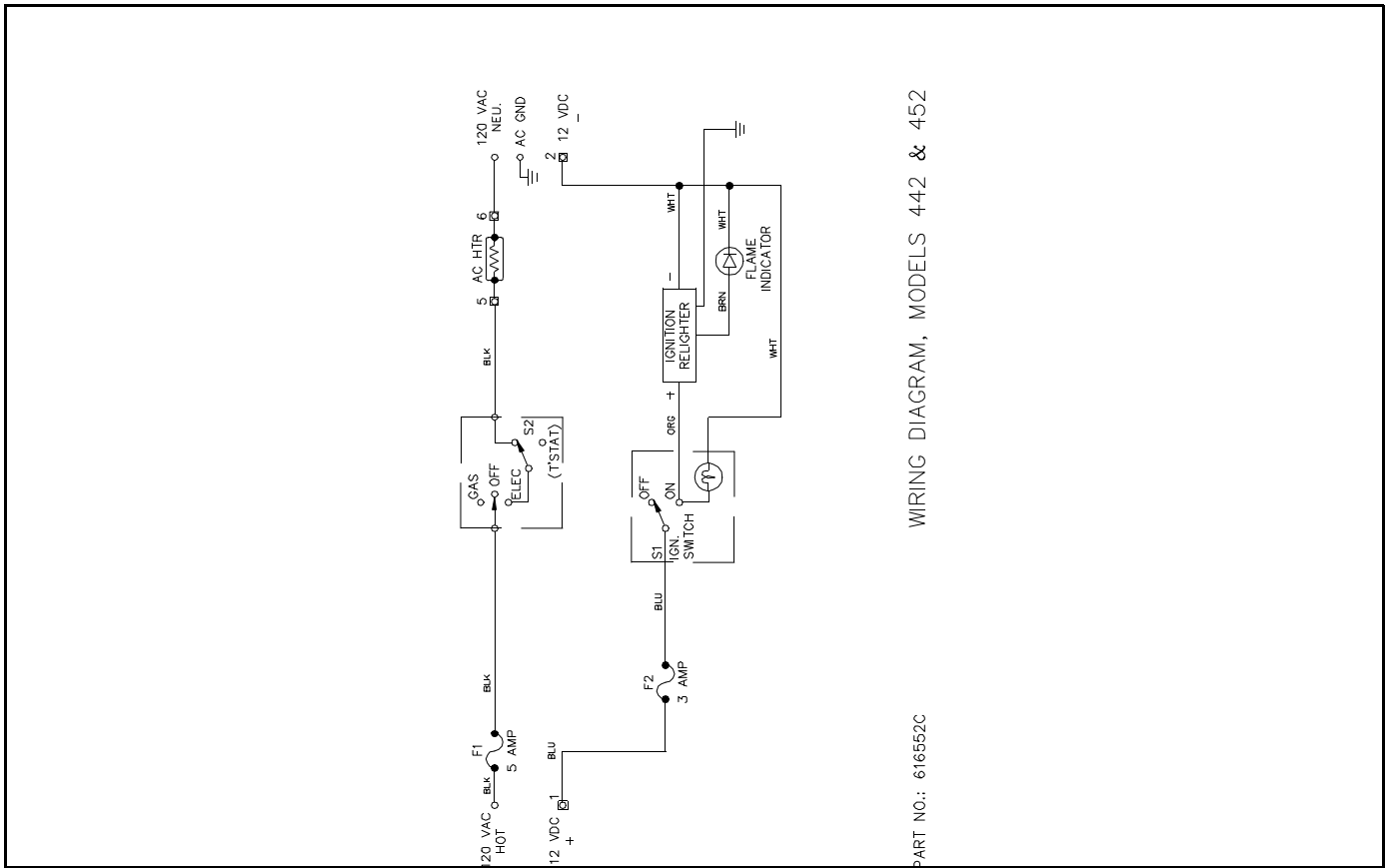

Figure 3.49







This Page Contains Information on Earlier Versions

On earlier versions of 3-Way models, the control panels were built with a 2-Position AC-DC switch. Later models have a 3-Position switch labeled "AC-ELECTRIC STANDBY-DC". See Figure 1 and 2.

5-Amp Fuse Blows Intermittently

Symptom:

- Blowing of 5 Amp fuse when switching from "AC" to "DC" or "DC" to "AC".
- When operating the refrigerator in the "ELEC" mode and the gas Ignition Switch is left "ON", components of the relighter can burn out when the 2-Position switch is changed from "AC" to "DC" or "DC" to "AC".

Possible Cause:

If the control panel has a 2-Position "AC-DC" switch, it may be defective.

Remedy:

Replace the AC/DC (2-Position) switch with the AC/ELECTRIC STANDBY/DC (3-Position) switch.

The replacement AC-DC Selector Switch (61694822) has a feature which the control panel nomenclature does not indicate.

The switch has a center position as shown in Figure 2.

The addition of the center position provides a user convenience and is labeled ELECTRIC STANDBY.

When operating in the electric mode, there are occasions when electric power needs to be temporarily shut off. (example: When operating in the DC mode, an RV makes a short stop, thereby shutting down the battery re-charge means. The user can flip the switch to ELECTRIC STANDBY to conserve battery charge.)

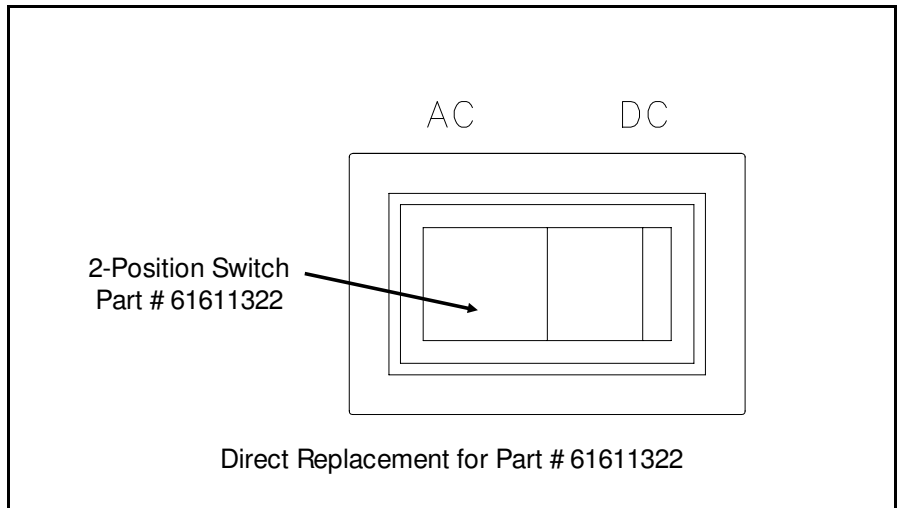

Figure 1 2-Position Switch

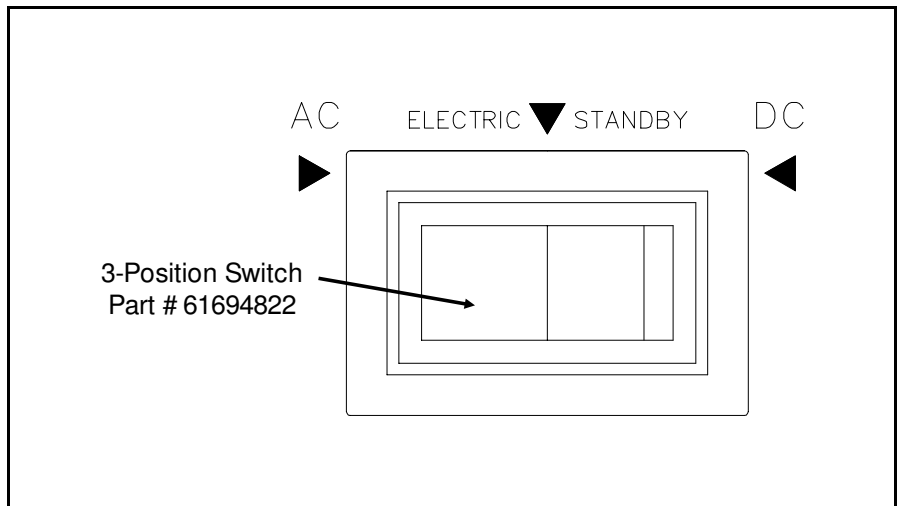

Figure 2 3-Position Switch

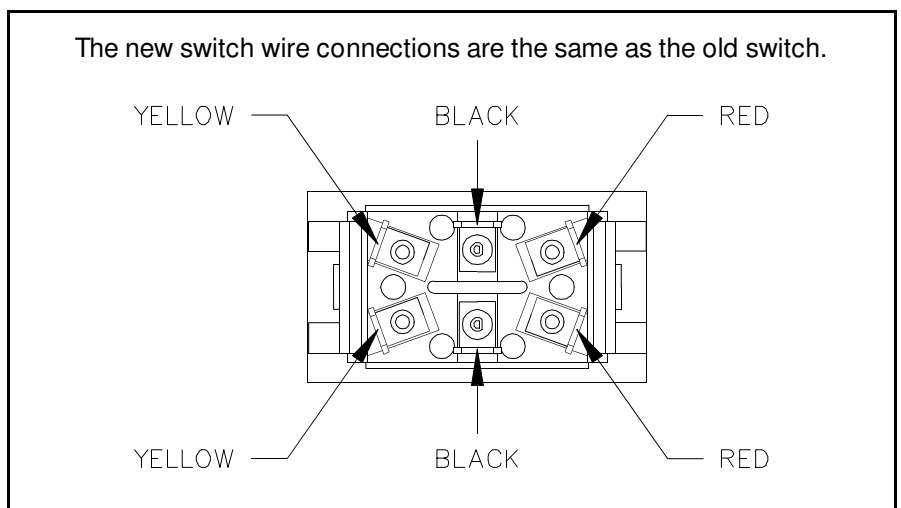
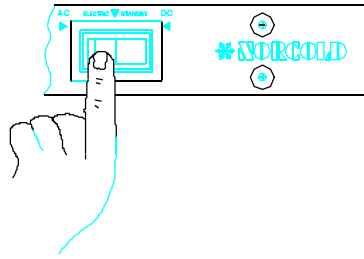

Figure 3

This Page Contains Information on Earlier Versions (continued)

61694822 AC - DC MODE SWITCH OPERATION

3-Way Model



Push on left side for 120 Volt AC mode

3-Way Model

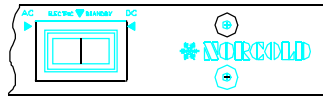

Center position for Electric Standby

3-Way Model

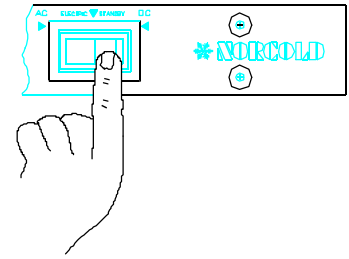

Push on right side for 12 Volt DC mode

This Page Contains Wiring Pictorials for Earlier Versions

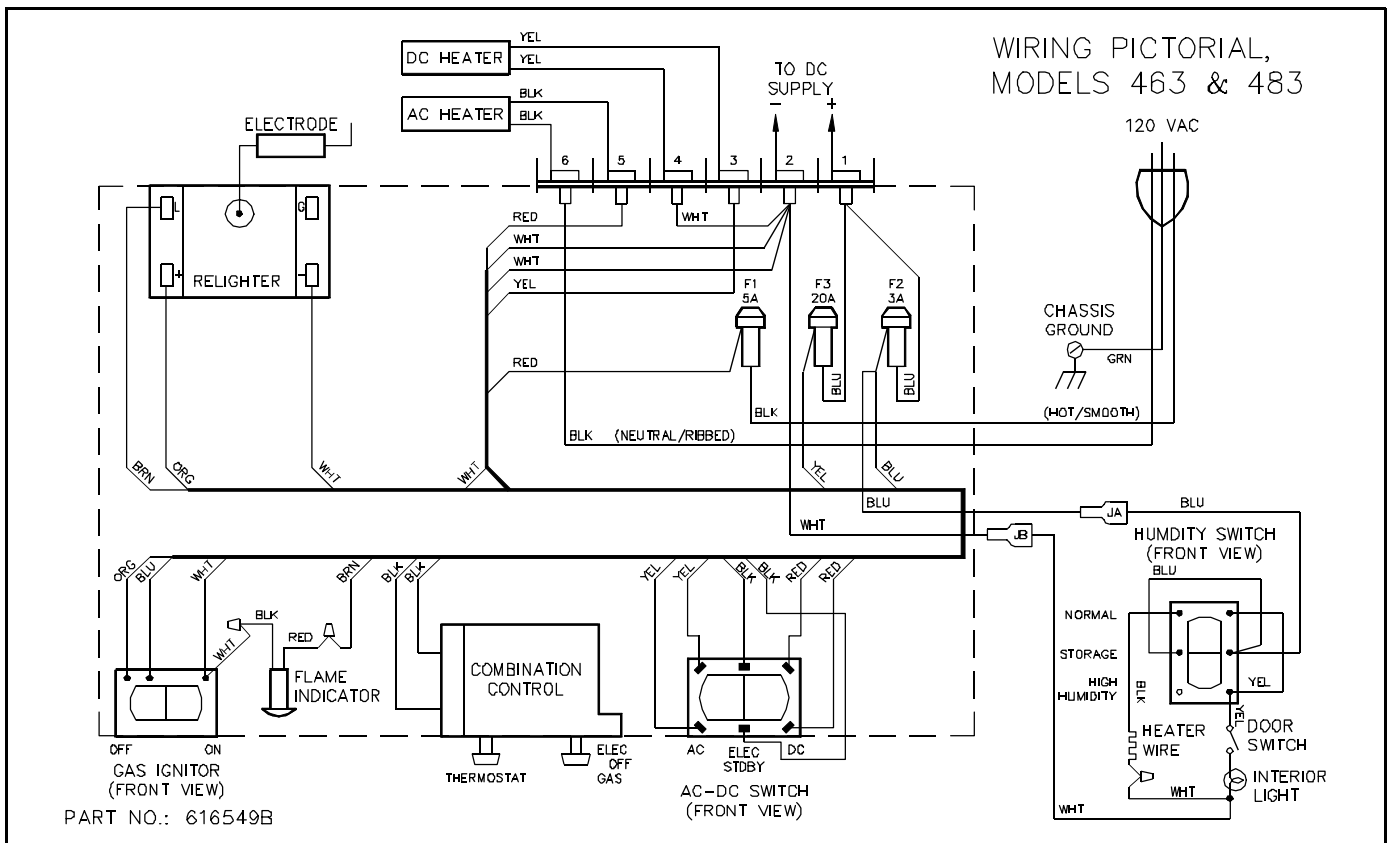
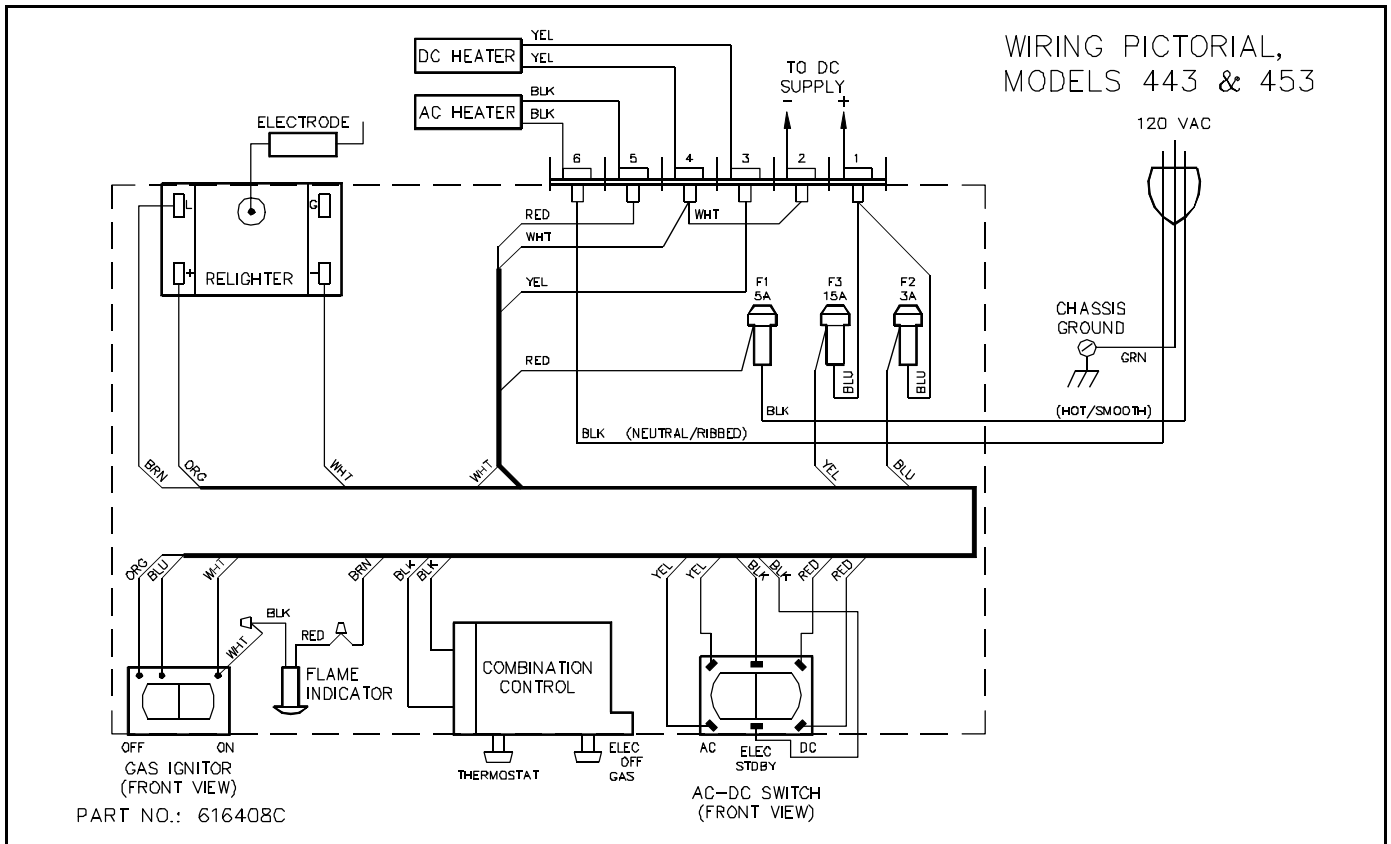

This Page Contains Wiring Pictorials for Earlier Versions

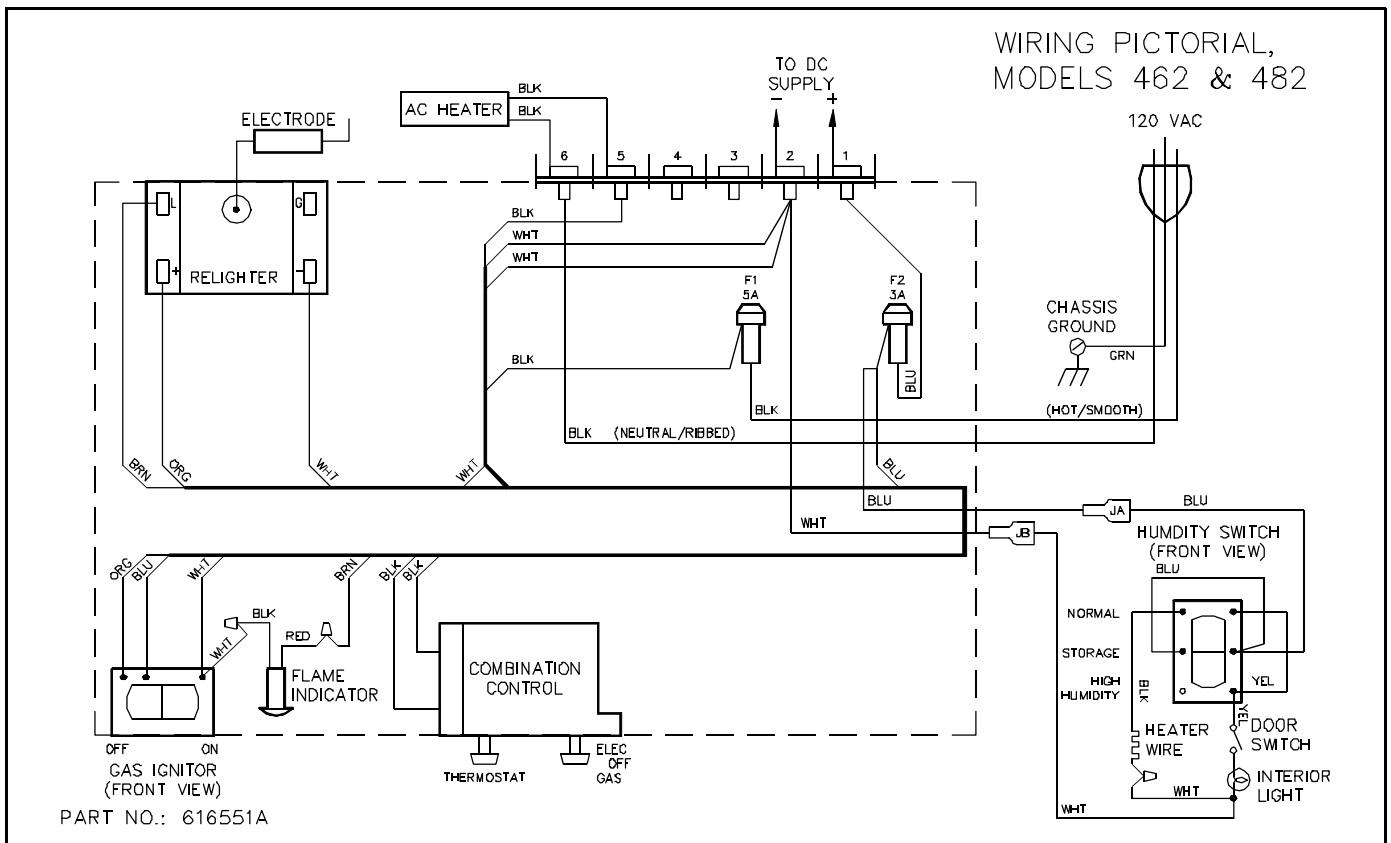
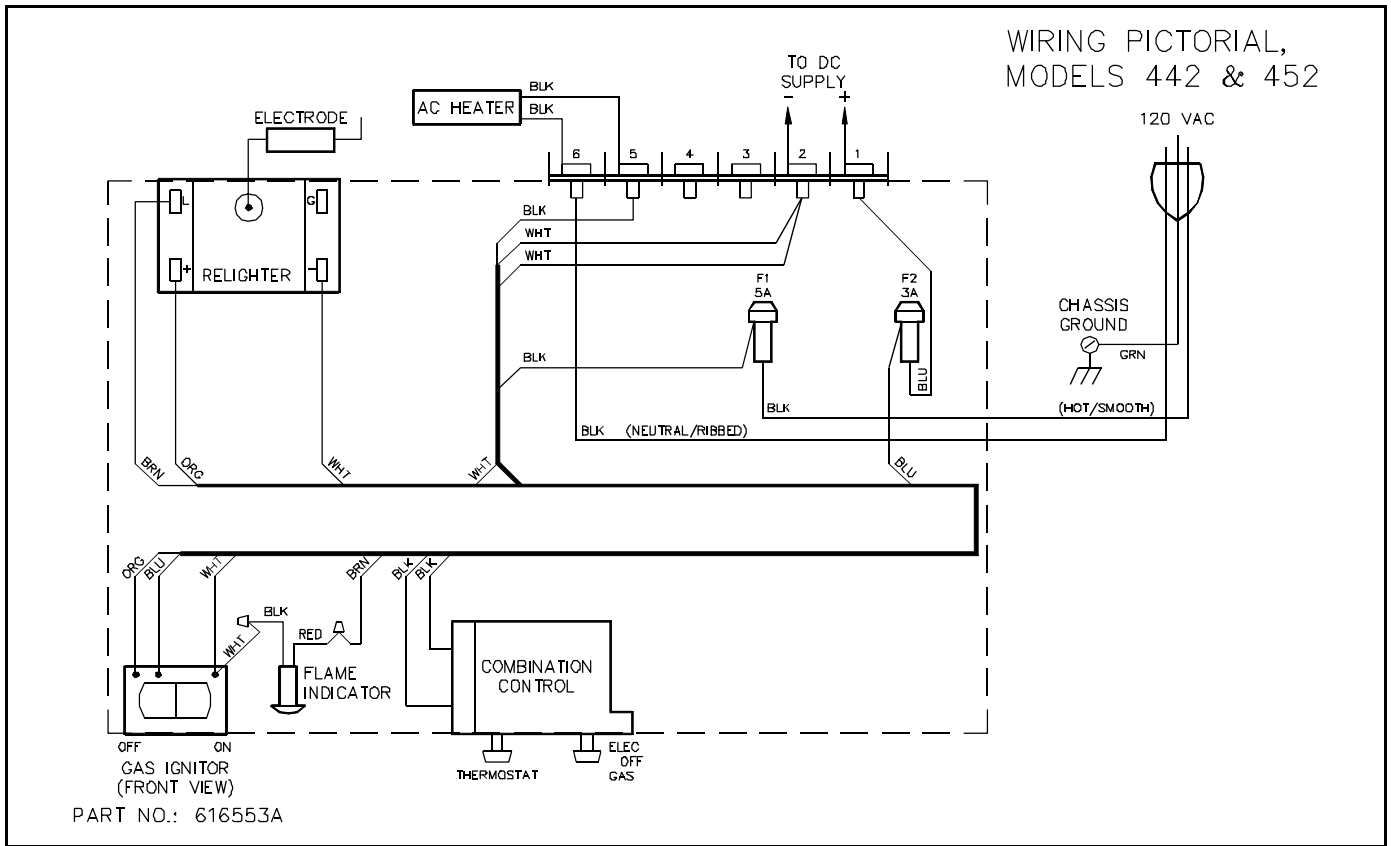

This Page Contains Wiring Diagrams for Earlier Versions

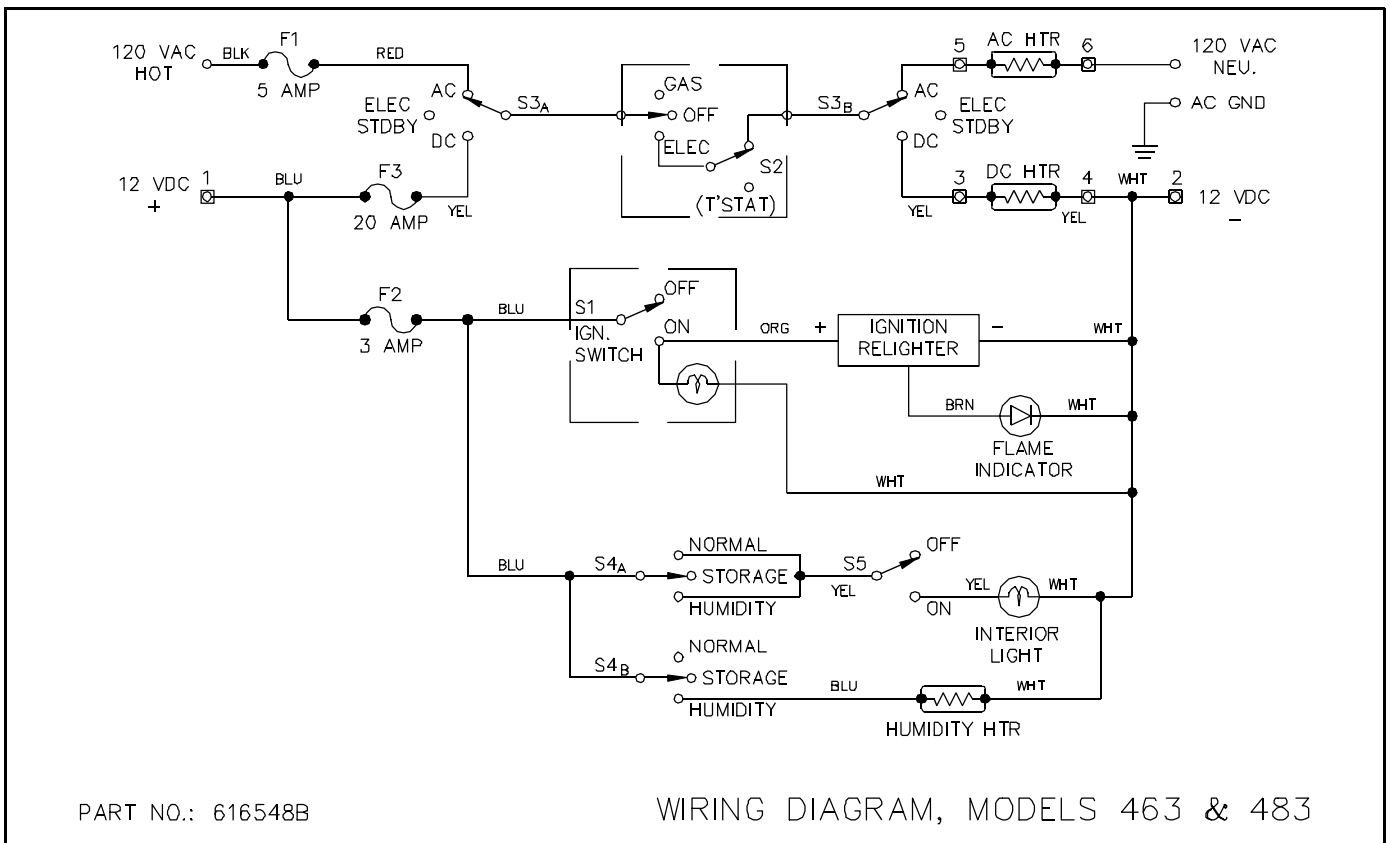
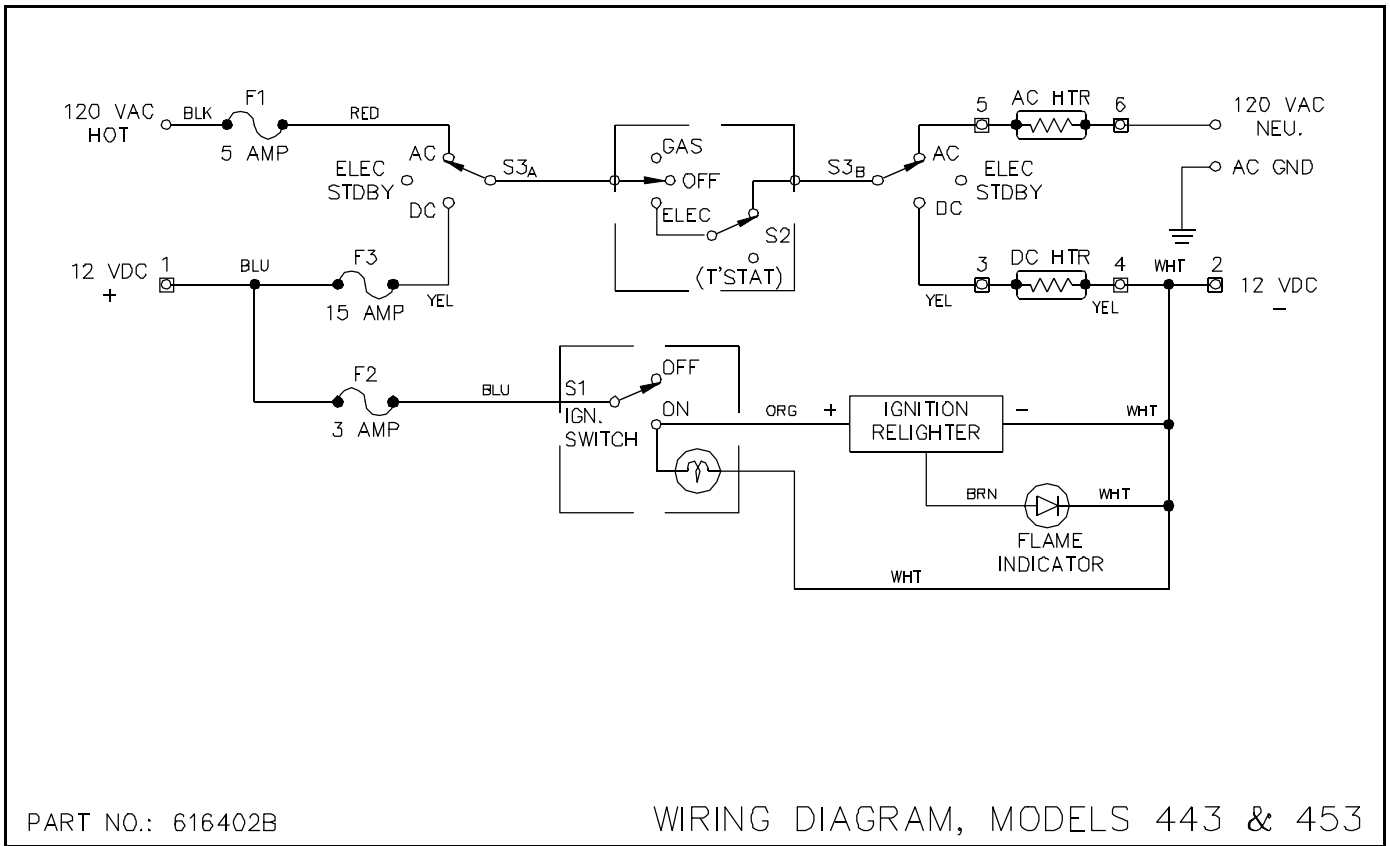

This Page Contains Wiring Diagrams for Earlier Versions

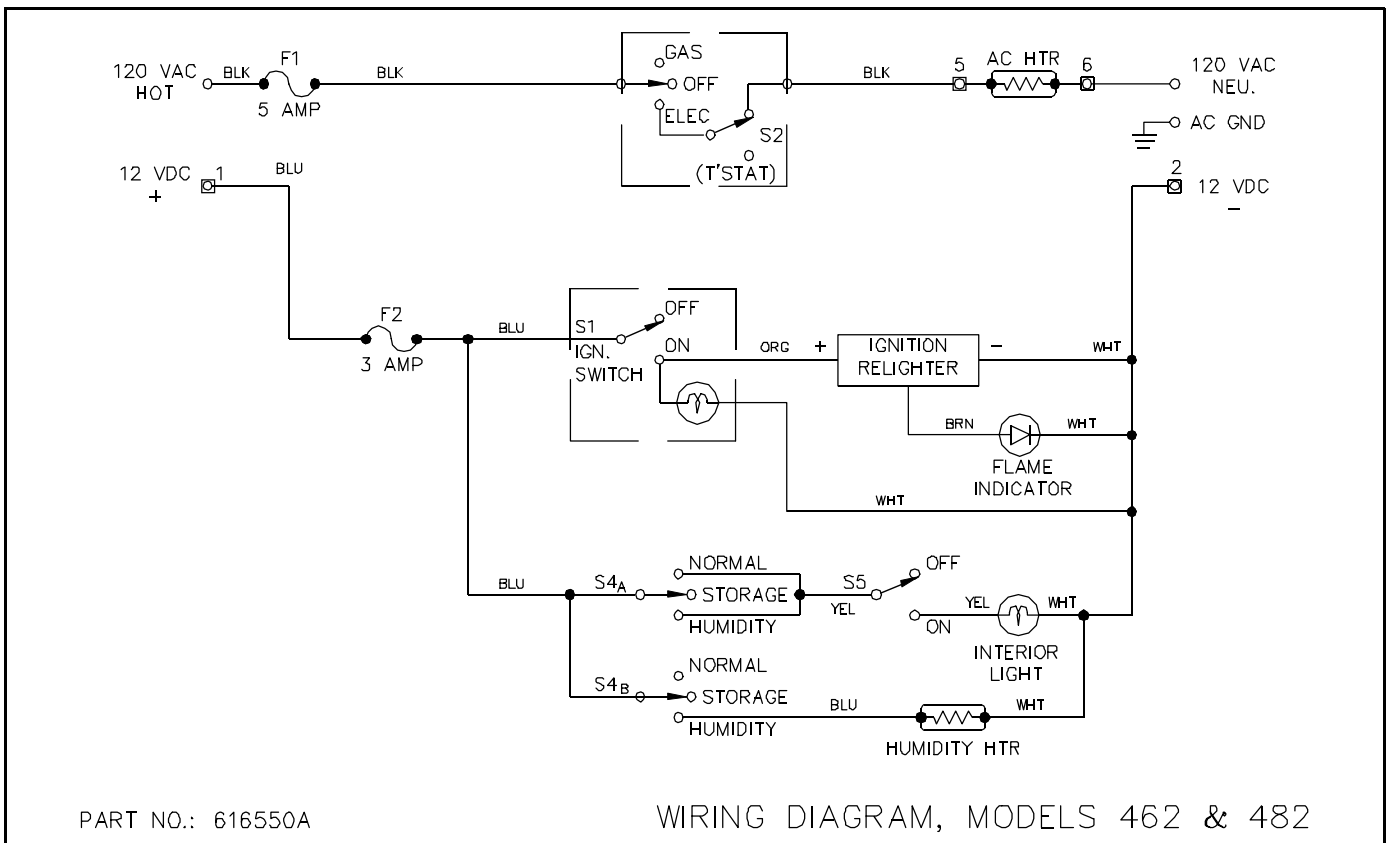
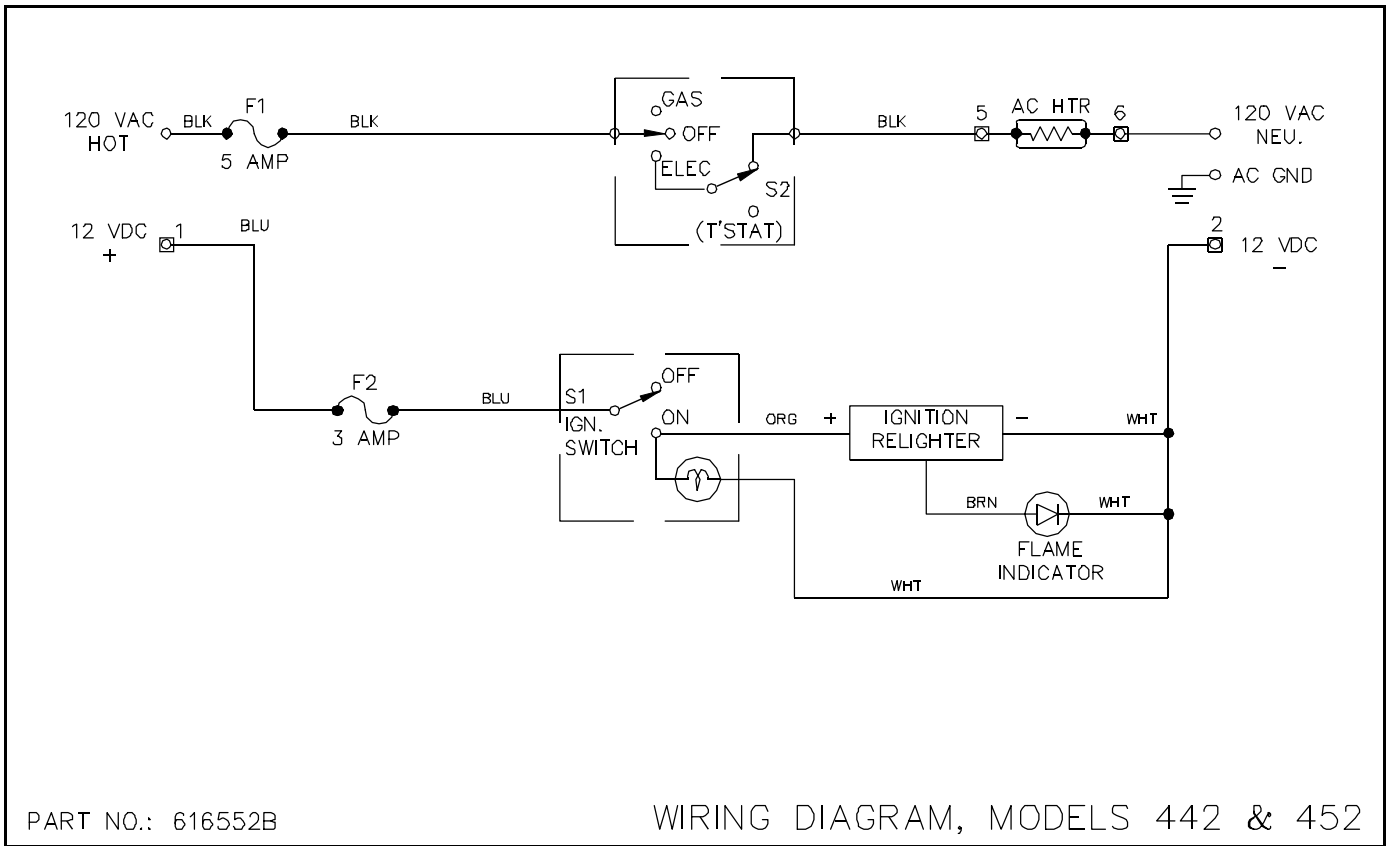

Manual provided courtesy
Bryant RV Services
www.byantrv.com

All manuals are believed to be released for distribution, and/or in the public domain.

Service manuals provided with the understanding that persons using them are well versed in proper safety practices, and are familiar with basic safety procedures, including, but not limited to safety procedures dealing with 120 volt electricity, high amperage 12 volt circuits an LPG (propane) systems.

If in doubt, consult a professional (better safe than sorry).