

RECORD THIS UNIT INFORMATION FOR  
 FUTURE REFERENCE:  
 Model Number \_\_\_\_\_  
 Serial Number \_\_\_\_\_  
 Date Purchased \_\_\_\_\_

**USA**  
 SERVICE OFFICE  
 Dometic Corp.  
 509 So. Poplar St.  
 LaGrange, IN 46761  
 260-463-4858

**CANADA**  
 Dometic Dist.  
 866 Langs Dr.  
 Cambridge, Ontario  
 CANADA N3H 2N7  
 519-653-4390

For Service Center  
 Assistance Call:  
 800-544-4881



**579 Series BRISK AIR  
 595 Series QUICK COOL  
 Roof Top Air Conditioners  
 Used With  
 3308417.009 Cooling & Furnace  
 3308417.025 Cooling, Furnace & Heat Strip  
 Remote Comfort Control Kit  
 Ducted**

THIS UNIT IS DESIGNED FOR OEM INSTALLATION  
 ALL INITIAL INSTALLATIONS MUST BE APPROVED BY THE DOMETIC CORP.

**! WARNING**

This manual must be read and understood before installation, adjustment, service, or maintenance is performed. This unit must be installed by a qualified service technician. Modification of this product can be extremely hazardous and could result in personal injury or property damage.

**! AVERTISSEMENT**

Lire et comprendre ce manuel avant de procéder à l'installation, à des réglages, de l'entretien ou des réparations. L'installation de cet appareil doit être effectuée par un réparateur qualifié. Toute modification de cet appareil peut être extrêmement dangereuse et entraîner des blessures ou dommages matériels.

**INSTALLATION  
 INSTRUCTIONS**

**MODELS**

- |           |           |
|-----------|-----------|
| 57915.331 | 57915.731 |
| 57915.336 | 59516.331 |
| 57915.531 | 59516.336 |
| 57915.536 | 59516.531 |
| 57915.541 | 59516.536 |
| 57915.546 | 59516.631 |
| 57915.631 |           |

**REVISION:**  
 Form No. 3308489.024 3/04  
 (Replaces 3308489.016)  
 (French 3308490.022)  
 ©2004 Dometic Corporation  
 LaGrange, IN 46761

**Important:** These instructions must stay with  
 unit. Owner read carefully.

## SAFETY INSTRUCTIONS

This manual has safety information and instructions to help users eliminate or reduce the risk of accidents and injuries.

### RECOGNIZE SAFETY INFORMATION



This is the safety-alert symbol. When you see this symbol in this manual, be alert to the potential for personal injury.

Follow recommended precautions and safe operating instructions.

### UNDERSTAND SIGNAL WORDS

A signal word, **WARNING OR CAUTION** is used with the safety-alert symbol. They give the level of risk for potential injury.

**WARNING** indicates a potentially hazardous situation which, if not avoided, could result in death or serious injury.

**CAUTION** indicates a potentially hazardous situation which, if not avoided may result in minor or moderate injury.

**CAUTION** used without the safety alert symbol indicates, a potentially hazardous situation which, if not avoided may result in property damage.

Read and follow all safety information and instructions.

## GENERAL INFORMATION

- A. Product features or specifications as described or illustrated are subject to change without notice.
- B. **This air conditioner is designed for:**
  1. Installation on a recreational vehicle at the time the vehicle is manufactured.
  2. Mounting on the roof of a recreational vehicle.
  3. Roof construction with rafters/joists on minimum of 16 inch centers.
  4. Minimum of 2.00" and maximum of 5.50" distance between roof to ceiling of recreational vehicle. Alternate installation methods will allow for roofs more than 5.50" thick.
- C. The ability of the air conditioner to maintain the desired inside temperature depends on the heat gain of the RV. Some preventative measures taken by the occupants of the RV can reduce the heat gain and improve the performance of the air conditioner. During extremely high outdoor temperatures, the heat gain of the vehicle may be reduced by:
  1. Parking the RV in a shaded area
  2. Using window shades (blinds and/or curtains)
  3. Keeping windows and doors shut or minimizing usage
  4. Avoiding the use of heat producing appliances.

Operation on High Fan/Cooling mode will give optimum or maximum efficiency in high humidity or high outside temperatures.

Starting the air conditioner early in the morning and giving it a "head start" on the expected high outdoor ambient will greatly improve its ability to maintain the desired indoor temperature.

For a more permanent solution to high heat gain, accessories like A&E outdoor patio and window awnings will reduce heat gain by removing the direct sun. They also add a nice area to enjoy company during the cool of the evening.

### D. Condensation

**Note:** The manufacturer of this air conditioner will not be responsible for damage caused by condensed moisture on ceilings or other surfaces. Air contains moisture and this moisture tends to condense on cold surfaces. When air enters the RV, condensed moisture may appear on the ceiling, windows, metal parts, etc. The air conditioner removes this moisture from the air during normal operation. Keeping doors and windows closed when this air conditioner is in operation will minimize condensed moisture on cold surfaces.

**SPECIFICATIONS**

MODEL NO.	NOMINAL CAPACITY (BTU/HR) COOLING	ELECTRICAL RATING	COMPRESSOR RATED LOAD AMPS	COMPRESSOR LOCKED ROTOR AMPS	FAN MOTOR RATED LOAD AMPS	FAN MOTOR LOCKED ROTOR AMPS	SCFM-HIGH SPEED MAX/MIN	TOTAL STATIC MIN/MAX "W. C.	REFRIGERANT R-22 (OZ.)	MINIMUM WIRE SIZE*	AC CIRCUIT PROTECTION *** USER SUPPLIED	INSTALLED WEIGHT (POUNDS)	MINIMUM GENERATOR SIZE** 1 UNIT/2 UNITS
57915.331	13,500	115VAC, 60 HZ., 1 PH.	11.4	58.0	2.5	5.8	325/250	0.55/0.90	15.5	12AWG Copper up to 24'	20 Amp	100	3.5KW/5.0 KW
57915.336	13,500		11.4	58.0	2.5	5.8	325/250	0.55/0.90	15.5		20 AMP	100	3.5KW/5.0 KW
57915.531	13,500		12.1	59.0	2.5	5.8	325/250	0.55/0.90	16.5		20 Amp	94	3.5KW/5.0 KW
57915.536	13,500		12.1	59.0	2.5	5.8	325/250	0.55/0.90	16.5		20 Amp	94	3.5KW/5.0 KW
57915.541	13,500		11.3	62.0	2.5	5.8	325/250	0.55/0.90	16.0		20 Amp	94	3.5KW/5.0 KW
57915.546	13,500	115VAC, 60 HZ., 1 PH.	11.3	62.0	2.5	5.8	325/250	0.55/0.90	16.0	12AWG Copper up to 24'	20 Amp	94	3.5KW/5.0 KW
57915.631	13,500		11.0	54.4	2.5	5.8	325/250	0.55/0.90	16.5		20 Amp	94	3.5KW/5.0 KW
57915.731	13,500		11.3	56.0	2.5	5.8	325/250	0.55/0.90	15.0		20 Amp	94	3.5KW/5.0 KW
59516.331	15,000		11.5	50.0	2.5	5.8	325/250	0.40/1.10	29.0		20 Amp	94	3.5KW/5.0 KW
59516.336	15,000		11.5	50.0	2.5	5.8	325/250	0.40/1.10	29.0		20 Amp	94	3.5KW/5.0 KW
59516.531	15,000		11.5	50.0	2.5	5.8	325/250	0.40/1.10	26.5		20 Amp	94	3.5KW/5.0 KW
59516.536	15,000	12.3	77.0	2.0	5.6	5.6	325/250	0.40/1.10	29.5		20 Amp	104	3.5KW/5.0 KW
59516.631	15,000												

\* For wire lengths over 24 ft. consult the National Electric Code for proper sizing.

\*\* Dometic Corporation gives **GENERAL** guidelines for generator requirements. These guidelines come from experiences people have had in actual applications. When sizing the generator, the total power usage of your recreational vehicle must be considered. Keep in mind generators lose power at high altitudes and from lack of maintenance.

\*\*\* **CIRCUIT PROTECTION:** Time Delay Fuse or HACR Circuit Breakers Required.

# INSTALLATION INSTRUCTIONS

## A. Precautions

### ⚠ WARNING

Improper installation may damage equipment, could endanger life, cause serious injury and/or property damage.

1. Read Installation and Operating instructions carefully before attempting to start your air conditioner installation.
2. Dometic Corporation will not be liable for any damages or injury incurred due to failure in following these instructions.
3. Installation must comply with the National Electrical Code and any State or Local Codes or regulations.
4. DO NOT add any devices or accessories to this air conditioner except those specifically authorized by Dometic.
5. This equipment must be serviced by qualified personnel and some states require these people to be licensed.

## B. Choosing Proper Location For The Air Conditioner

This air conditioner is specifically designed for installation on the roof of a recreational vehicle (RV). When determining your cooling requirements, the following should be considered:

- Size of RV;
  - Window area (increases heat gain);
  - Amount of insulation in walls and roof;
  - Geographical location where the RV will be used;
  - Personal comfort level required.
1. Normal Location-The air conditioner is designed to fit over an existing roof vent opening.

FIG. 1

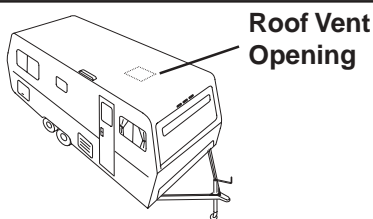

2. Other Locations-When no roof vent is available or another location is desired, the following is recommended:
  - a. For One Unit Installation: The air conditioner should be mounted slightly forward of center (front to back) and centered from side to side. See FIG. 2.

- b. For Two Unit Installations: Install one air conditioner one-third and one air conditioner two-thirds from front of RV and centered from side to side. See FIG. 2.

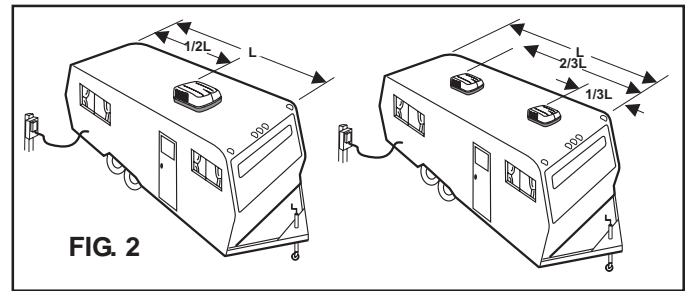

It is preferred that the air conditioner be installed on a relatively **flat and level** roof section measured with the RV parked on a level surface.

**Note:** Up to a 15° slant to either side or front-to-back is acceptable.

3. After Location Has Been Selected:
  - a. Check for obstructions on the roof and ceiling where air conditioner will be installed. See FIG. 3.
  - b. The roof must be designed to support 130 pounds when the RV is in motion. Normally 200 pound static load design will meet this requirement.

### CAUTION

It is the responsibility of the installer of this air conditioner system to ensure structural integrity of the RV roof. Never create a low spot on the roof where water will collect. Water standing around the air conditioner may leak into the interior causing damage to the product and the RV.

FIG. 3

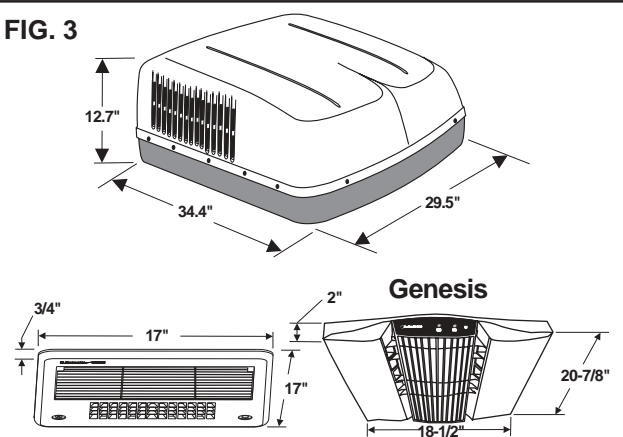



**CAUTION**

**It is the responsibility of the installer to insure the duct-work will not collapse or bend during and after the installation. Dometic Corporation will not be liable for roof structural or ceiling damage due to improperly insulated, sealed or collapsed duct-work.**

## 4. Air Distribution System Sizing &amp; Design

The Installer of this air conditioner system must design the air distribution system for this particular application. Several requirements for this system **MUST** be met for the air conditioner to operate properly. These requirements are as follows:

- a. The duct material must meet or exceed any agency or RVIA Standard that may be in existence at the time the RV is produced.
- b. All discharge air ducts must be properly insulated to prevent condensation from forming on their surfaces or adjacent surfaces during operation of the air conditioner. This insulation must be R-7 minimum.

- c. Ducts and their joints must be sealed to prevent condensation from forming on adjacent surfaces during operation of the air conditioner.
  - d. Return air openings must have 40 square inches minimum free area including the filter.
  - e. Return air to the air conditioner must be filtered to prevent dirt accumulation on air conditioner cooling surface.
5. Air Distribution System Installation
- a. Dometic Corporation recommends the basic configuration shown in FIG. 7A, 7B and 7C for installing this air conditioner system. We have found by testing, that this configuration works best in most applications of this air conditioner system. It is the responsibility of the Installer of this system to review each RV floor plan and determine the following:
    - Duct size
    - Duct layout
    - Register size
    - Register location
    - Receiver location

### AIR DISTRIBUTION DUCT SIZING & DESIGN CHART

<b>Return Air Cover Model</b>	3105007 3105935	3308120 Genesis Air Filtration System
<b>Roof Cavity Depth</b>	2.0 In. Min. - 5-1/2 In. Max.	2.0 In. Min. - 5-1/2 In. Max.
<b>Total Duct Cross Sectional Area</b>	21.0 Sq. In. Min.	32.0 Sq. In. Min.
<b>Duct Size</b> Depth Width Total Duct Length Duct Length (short run)	1-1/2 In. Min. - 2-1/2 In. Max. 7.0 In. Min. - 10.0 In. Max. 15.0 Ft. Min. - 40.0 Ft. Max. 1/3 Total Duct Length	2.0 In. Min. - 2-1/2 In. Max. 8.0 In. Min. - 10.0 In. Max. 15.0 Ft. Min. - 40.0 Ft. Max. 1/3 Total Duct Length
<b>Register Requirements</b> Number Required Per Run Register Free Air Area Distance From Duct End Distance From Elbow	4 Min. 14.0 Sq. In. 5.0 In. Min. - 8.0 In. Max. 15.0 In.	4 Min. 14.0 Sq. In. 5.0 In. Min. - 8.0 In. Max. 15.0 In.
<b>Total System Static Air Pressure Blower at High Speed, Filter &amp; Grill In Place</b>	0.55 - 0.90 In. W.C. 579 Series 0.40 - 1.10 In. W.C. 595 Series	0.55 - 0.90 In. W.C. 579 Series 0.40 - 1.10 In. W.C. 595 Series

**Note:** Duct sizes listed are inside dimensions.

These items must be determined in conjunction with the Air Distribution System and Sizing and Design Requirements listed in the chart on page 6. Terminate the start of the duct at the back edge of the 14-1/4" x 14-1/4" (±1/8") opening)

**Important:** Alternate configurations and methods may be used which still allow the air conditioner to operate properly; however, these alternate configurations and methods must be approved by the Dometic Corporation in writing. The following instructions are based upon the use of Dometic Return Air Kits 3105007 Return Air Cover, 3105935 Quick Cool Return Air Cover or 3308120 Genesis Air Filtration System. The 3107180.006 Bolt/Cover Kit has the mounting bolts and cover for the AC junction box for use with these kits.

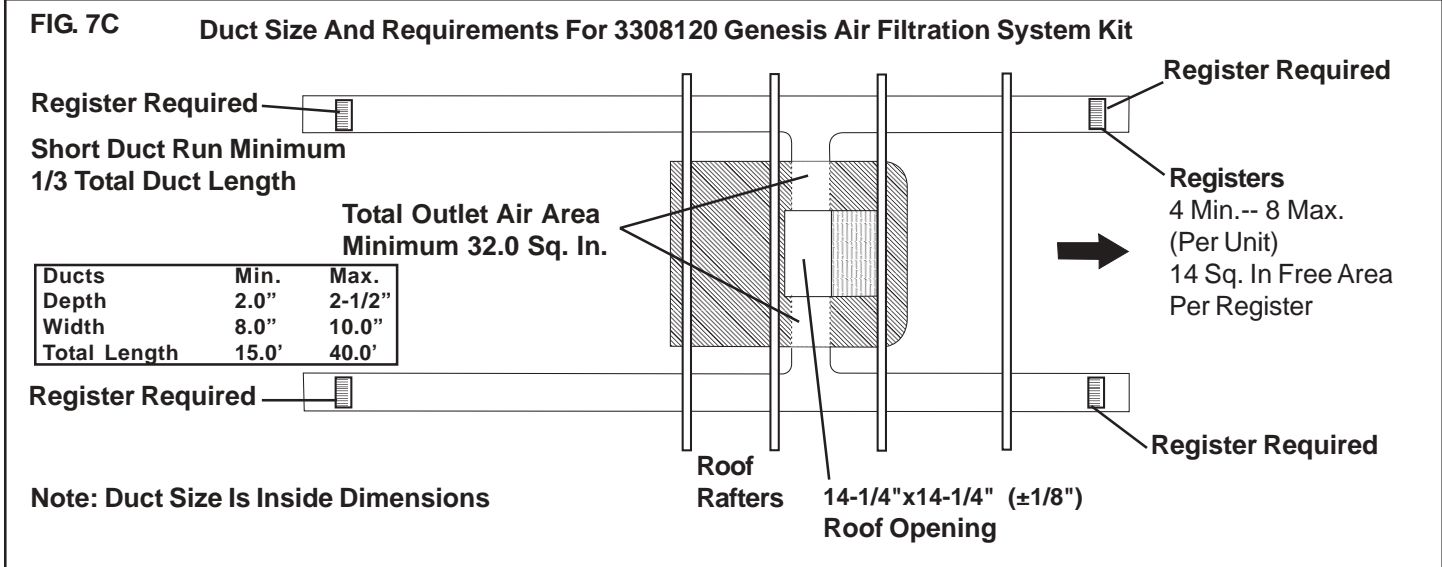
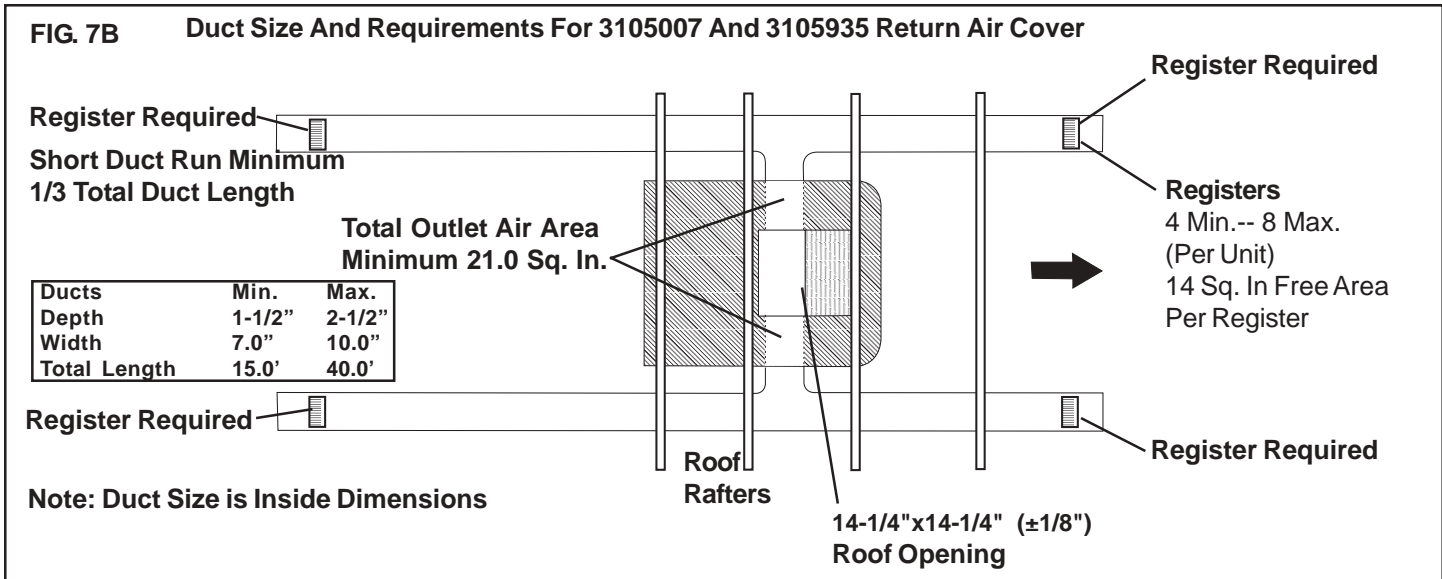
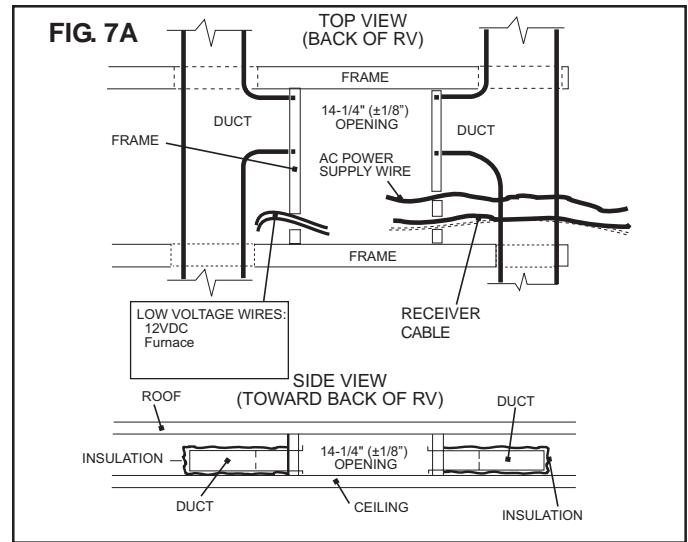

## D. Wiring Requirements

1. 115 VAC Supply Line
 

Route a copper 12 AWG, with ground, 115 VAC supply line from the fuse or circuit breaker box to the roof opening.

  - a. This supply line must be located in the front portion of the 14-1/4" x 14-1/4" ( $\pm 1/8$ ") opening.
  - b. The power **MUST** be on a separate 20 Amp time delay fuse or HACR circuit breaker.
  - c. Make sure that at least 15" of supply wire extends into the roof opening. This ensures and easy connection at the junction box.
  - d. Wiring must comply with all National, State and Local Wiring Codes.
  - e. Use a steel sleeve and a grommet or equivalent methods to protect the wire where it passes into the opening.
2. Route a dedicated 12 VDC supply line (18-22 AWG) from the RV's converter or battery to the roof opening.
  - a. This supply line must be located in the front portion of the 14-1/4" x 14-1/4" ( $\pm 1/8$ ") opening.
  - b. Make sure that at least 15" of supply wire extends into the roof opening.
3. If system includes a gas furnace, route two 18 gauge thermostat wires from the furnace to roof opening of the air conditioner that will control it. If more than one furnace is to be used, route the second set of thermostat wire to the second air conditioner. Make sure that 15" of wire extends into the opening.
4. Route a 4-conductor receiver cable from the **Receiver** mounting position into the roof opening. Make sure that at least 15" of the wire extends into the roof opening and 6" extend at the mounting position of the **Receiver**. See Section E-2.

## E. Receiver & Cable Installation

**Note:** The receiver monitors the temperature of the living area. The following receiver location is recommended to maintain the selected temperature setting. Any other location must be approved by Dometic. See FIG. 9.

1. Locate the receiver in a front to rear position on the ceiling, and to one side or the other of the return air cover. See FIG. 8A, 8B & 8C. Mounting the receiver from side to side is not recommended, but could be mounted this way as a last possibility.

**Note:** When used with the 3308120 Genesis Filtration System, do not mount the receiver where it will interfere with the filter removal. See FIG. 8A. When used with the 3105935 Quick Cool Return Air Grille do not install near the discharge air duct. See FIG. 8C.

**Note:** To operate the air conditioner, the receiver must be installed in a location that will allow the remote to be in

FIG. 8A 3308120 Genesis Filtration System

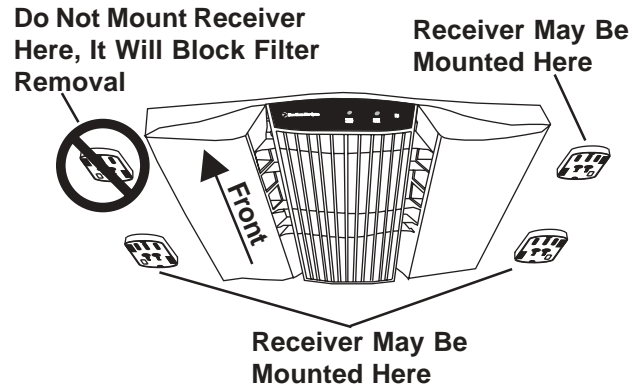

FIG. 8B 3105007 Return Air Grille

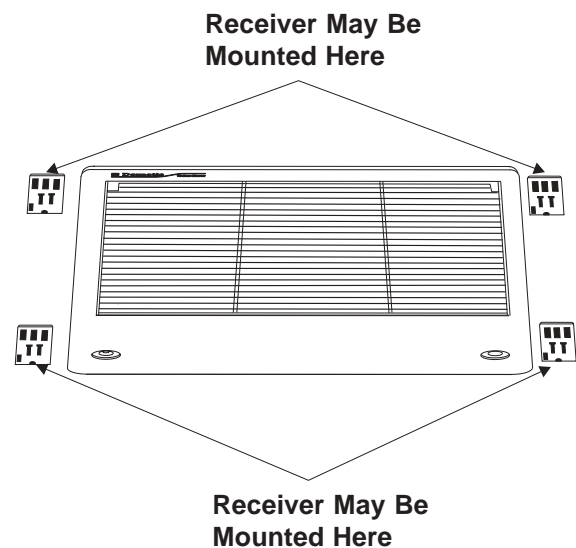
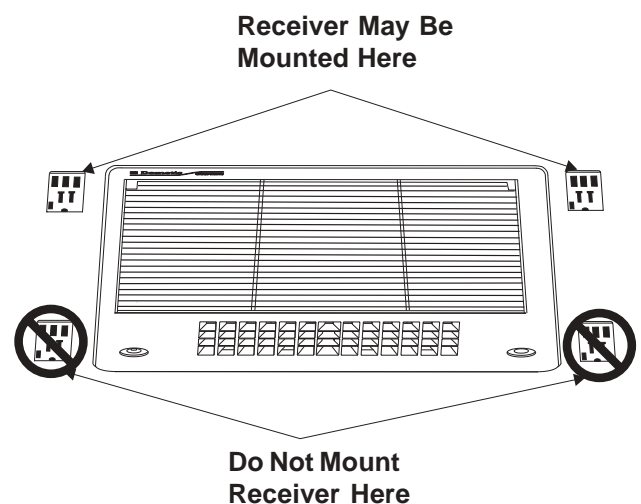
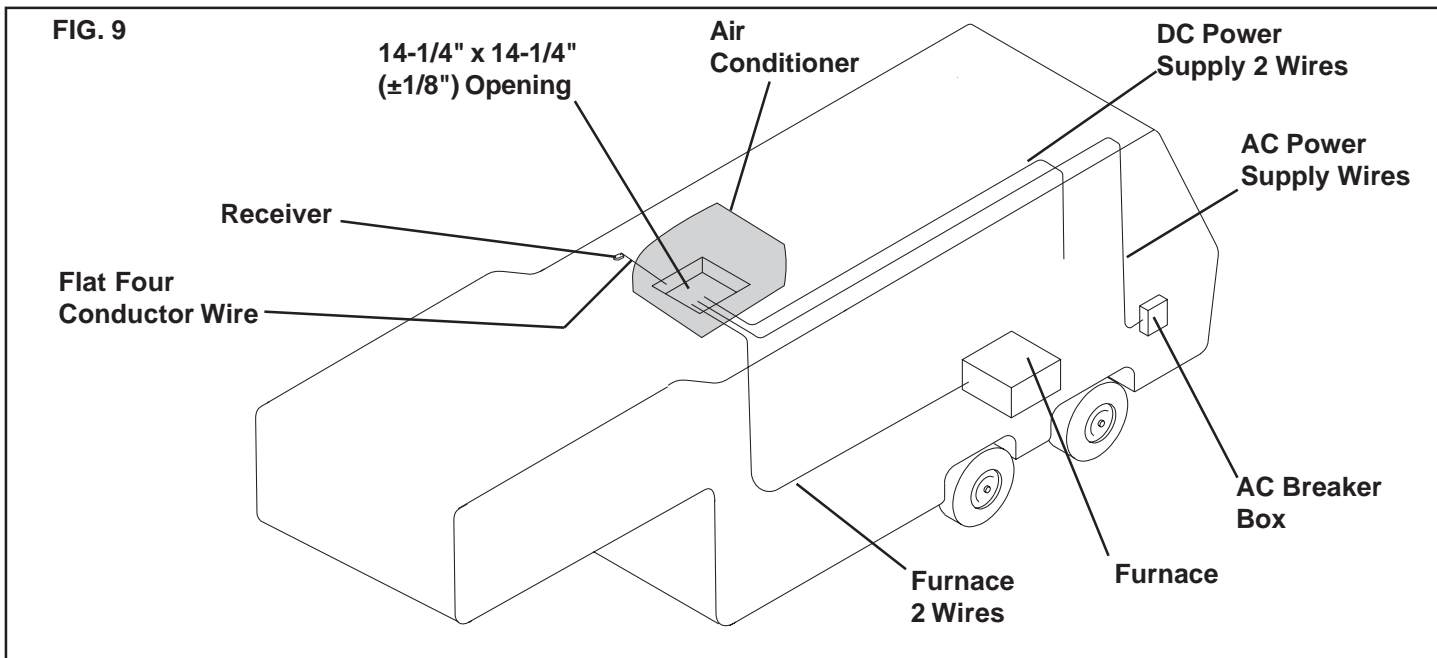

FIG. 8C 3105935 Return Air Grille





the line of sight of the receiver.

- a. If another receiver mounting location is anticipated, observe the following general rules in determining the location and submit location to Dometic for approval.
  - Locate the Receiver 54" above the floor.
  - **NEVER** expose it to direct heat from lamps, sun or other heat producing items.
  - Avoid locations close to doors that lead outside, windows or adjoining outside walls or directly under cabinets or overhangs which limit air movement.
  - Avoid locations close to supply registers and the air from them.
  - **NEVER** locate receiver in a room that is warmer or cooler than the rest of the RV.
  - The major living area is normally a good location.

2. Receiver Cable Installation

A 4-conductor receiver cable must be routed from the roof opening to the **Receiver**:

- a. Choose the shortest, most direct route from the 14-1/4" x 14-1/4" (±1/8") opening to the **Receiver** location selected. Leave 6" of cable extending through the wall. See Section D-4.
- b. The receiver cable that should be used is a flat, 4-conductor telephone cable.
- c. The receiver cable must be terminated with two (2) RJ-11 telephone connectors. Refer to the crimp tool manufacture for crimping instruc-

tions.

**Important: RJ-11 connectors must be installed as**

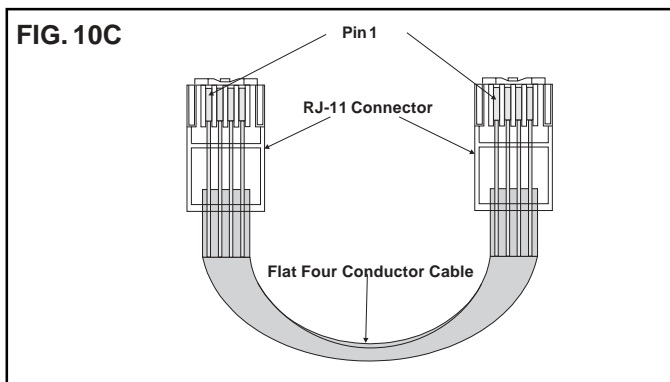
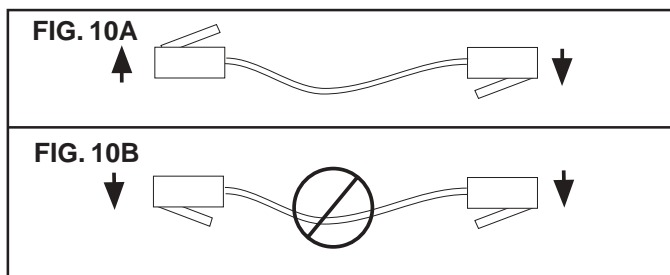

shown in FIG. 10A, 10B and 10C.

### F. PLACING THE AIR CONDITIONER ON THE ROOF

1. Remove the air conditioner from the carton. The unit mounting bolts and literature are in a separate plastic bag. Be sure to place this information in the

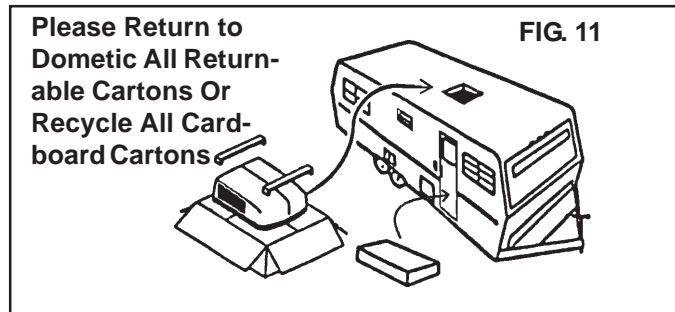

**CAUTION**  
 This unit weighs approximately 100 pounds. To prevent back injury, use a mechanical hoist to place air Conditioner on roof.

- RV.
2. Place the air conditioner on the roof.
3. Lift and place the unit over the prepared opening using the gasket on the unit as a guide. The roof gasket on the bottom of the base pan goes toward the front of the RV. Sliding the unit on the

**CAUTION**  
 Do not slide the unit. This may damage the roof gasket attached to the bottom and create a leaky installation.

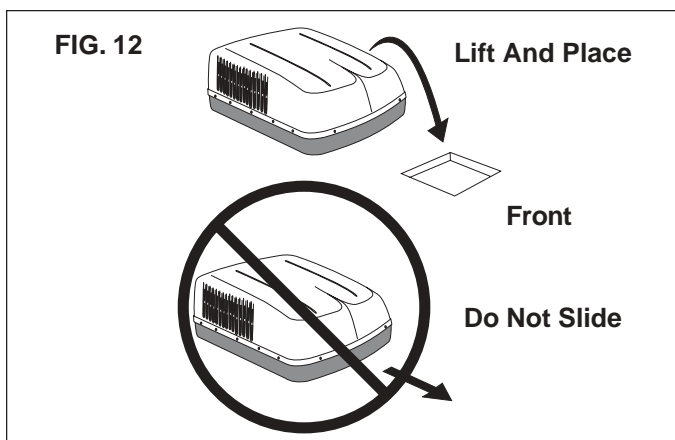

roof will damage the roof gasket. See FIG. 12.

### G. Installing Air Conditioner

- Installing unit with 3105007 or 3105935 Return Air Cover. For unit with Genesis Air Filtration System

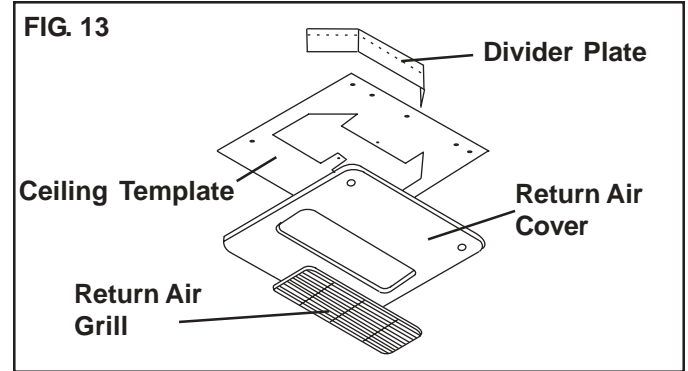

see page 12.

1. Installation Of Ceiling Template
  - a. Check gasket alignment of the air conditioner over the roof opening and adjust if necessary. Unit may be moved from below by slightly lift-

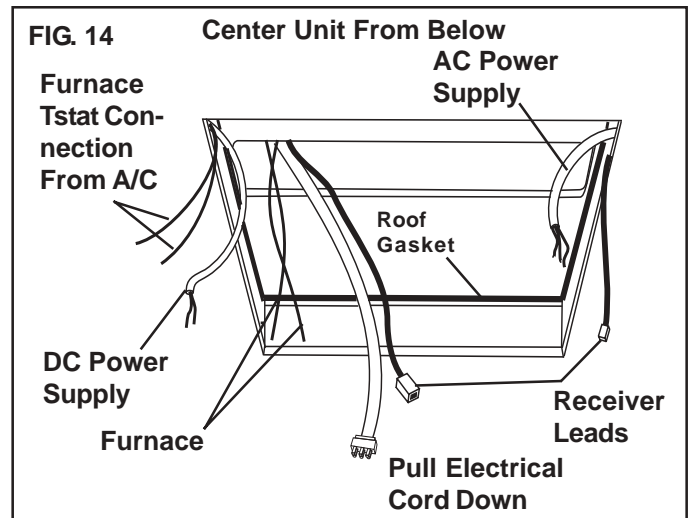

- b. Remove return air cover and ceiling template from the 3105007 or 3105935 kit carton.
- c. Locate the four (8" x 1/4-20) unit mounting bolts packaged with the 3308417 control kit.
- d. Reach up into the return air opening and pull the unit electrical cord down. See Section "H. Wiring the system".
- e. Route AC power supply wires through the Romex connector in the control box.
- f. Connect the 6 pin plug to the control box. The plug is polarized and will only fit in one direc-

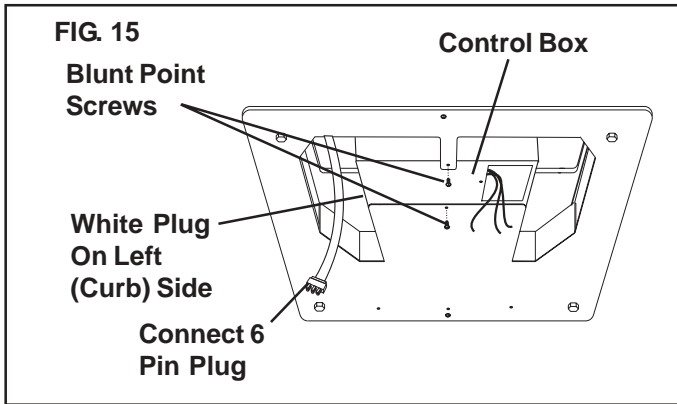

tion. See FIG. 15

- g. Snap freeze control into place on return bend located at left (curb side) side of evaporator coil as follows:
- Locate "D" shaped notch in flange of evaporator coil. See FIG. 16.
  - Place the horseshoe end of the freeze control through this notch and snap onto the coil return bend. When positioned correctly, control wires will be toward the evaporator housing away from the evaporator coil header. See FIG. 16.
  - Remove installation notice hang tag from

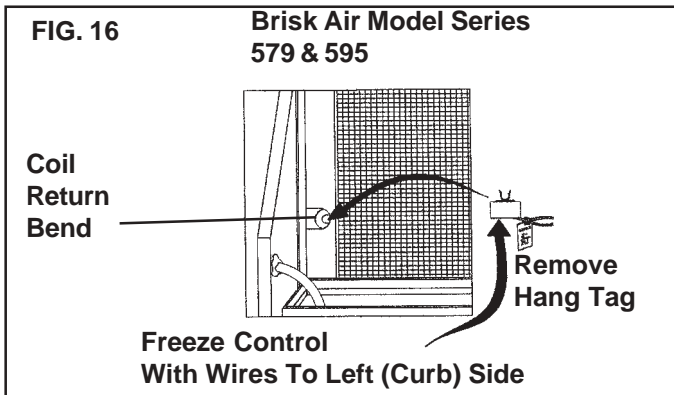

freeze control. See FIG. 16.

- h. Place the relay control box on the ceiling template with the white 6 connector plug on the left (curb side) side of RV. See FIG. 15.
- i. Hold the ceiling template up to the 14-1/4" x 14-1/4" ( $\pm 1/8$ ") opening. Be sure the large plate

faces the rear of the RV.

- Start each mounting bolt through the ceiling template and up into the unit base pan by hand. Install wood screw in each end of the ceiling template. This insures a tight fit of the return air cover to ceiling. See FIG.

### CAUTION

If bolts are left loose there may not be adequate roof seal or if over tightened, damage may occur to the air conditioner base or ceiling template. Tighten to specifications listed in this manual.

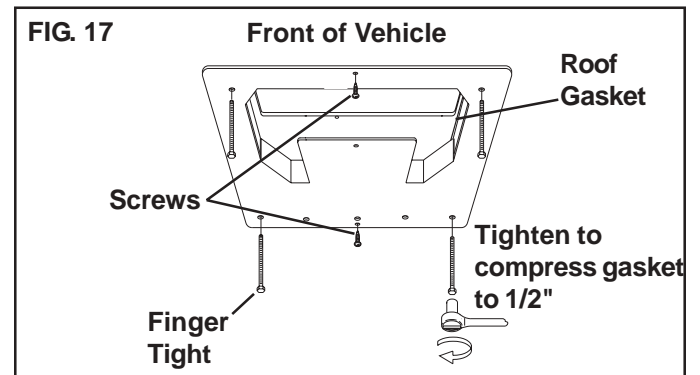

17.

- **EVENLY** tighten the bolts to a torque of 40 to 50 inch pounds. This will compress the roof gasket to approximately 1/2". The bolts are self locking so over tightening is not necessary. See FIG. 17.
2. Installation Of Divider Plate
- Measure the ceiling to roof thickness:
    - If distance is 2.0" - 3-3/4", remove perforated tab from divider plate.
    - If distance is 3-3/4" - 5-1/2", remove no tabs.
  - Remove the backing paper from double sided

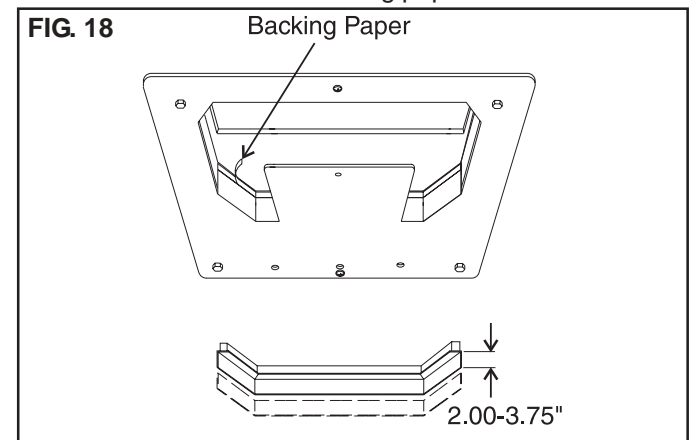

tape located on ceiling template. See FIG. 18.

- c. Place divider plate up to bottom of air conditioner base pan firmly. The foam tape on the divider plate must seal to bottom of base pan.

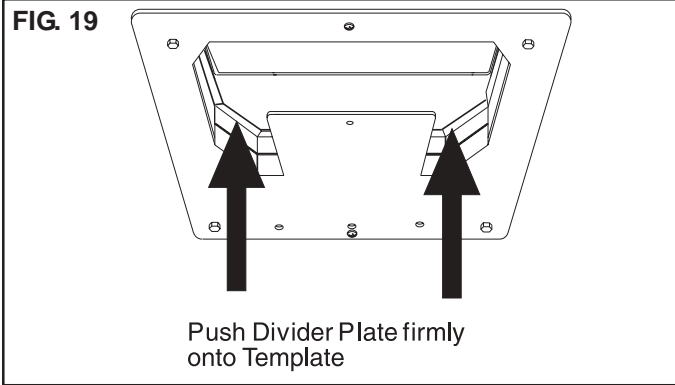

See FIG. 19.

**Note:** The adhesive on the insulation is extremely sticky. Be sure the part is located where desired before pressing into place.

- d. With slight pressure then push the divider plate against the double sided tape on the ceiling template.
- e. Locate the 1/8" x 7" x 18" self-adhesive insulation supplied with the return air kit. Remove the backing paper from the insulation and carefully stick onto the ceiling template divider

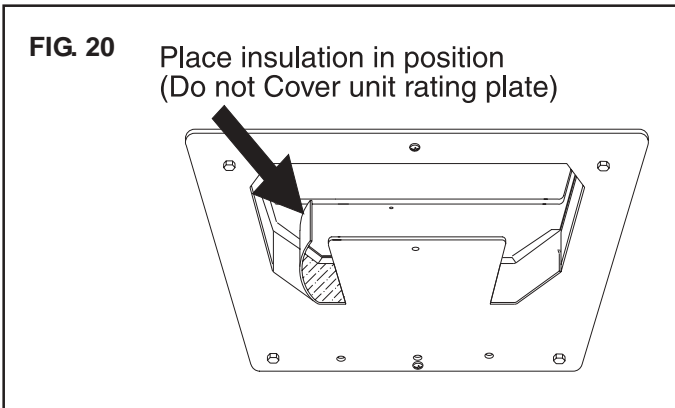

panel. See FIG. 20.

- Excess width is intended to seal the divider plate to the sides of the 14-1/4" x 14-1/4" (±1/8") opening. This is to help prevent cold air discharge from circulating into the air conditioner return air opening.
- If the insulation is too high, stick excess height of insulation to the air conditioner base pan. Do not cover up unit rating plate.

■ Installing unit with 3308120 Genesis Air Filtration System Return Air Kit. For unit with 3105007 or

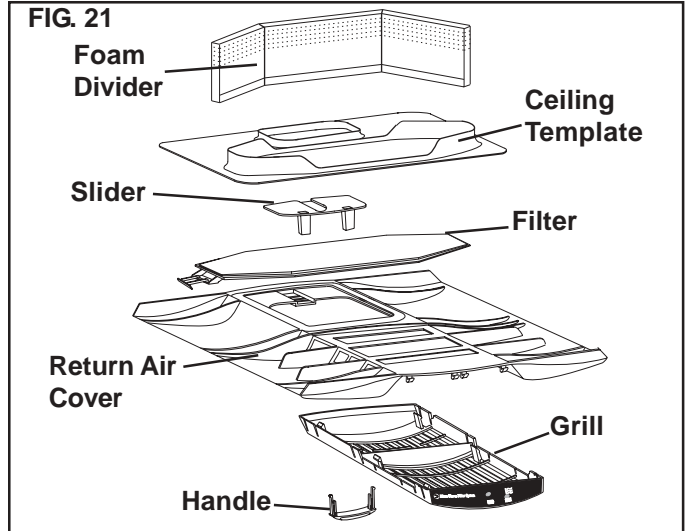

3105935 Return Air Kit, see page 10.

1. Non Center Duct Installations  
Check gasket alignment of the air conditioner over the roof opening and adjust if necessary. Unit may

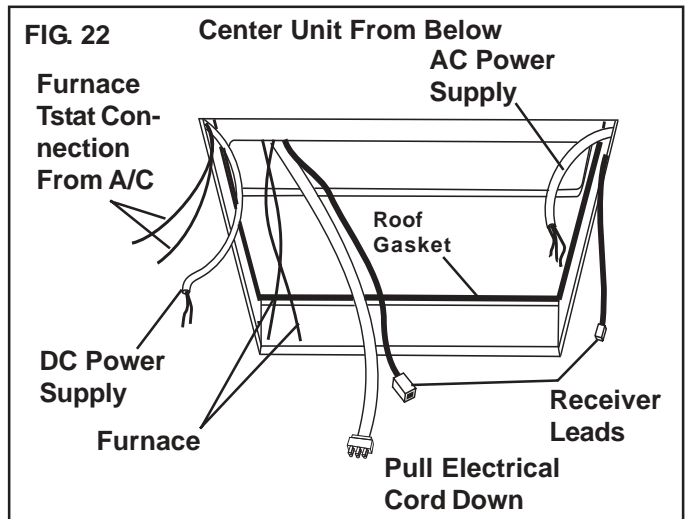

be moved from below by slightly lifting. See FIG.22.

- a. Locate the four (8" x 1/4-20) unit mounting bolts packaged with the 3308417 control kit.
- b. Reach up into the return air opening and pull the unit electrical cord down.
- c. Route AC power supply wires through the Romex connector in the control box.
- d. Connect the 6 pin plug to the control box. The plug is polarized and will only fit in one direc-

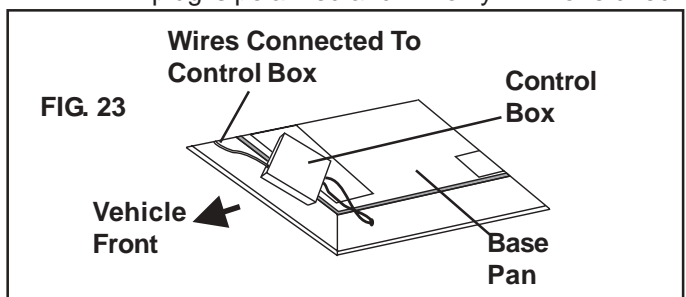

- tion. See FIG. 23
- e. Snap freeze control into place on return bend located at left (curb side) side of evaporator coil as follows:
  - f. Locate "D" shaped notch in flange of evaporator coil. See FIG. 24.
  - g. Place the horseshoe end of the freeze control through this notch and snap onto the coil return bend. When positioned correctly, control wires will be toward the evaporator housing away from the evaporator coil header. See FIG. 24.
  - h. Remove installation notice hang tag from freeze

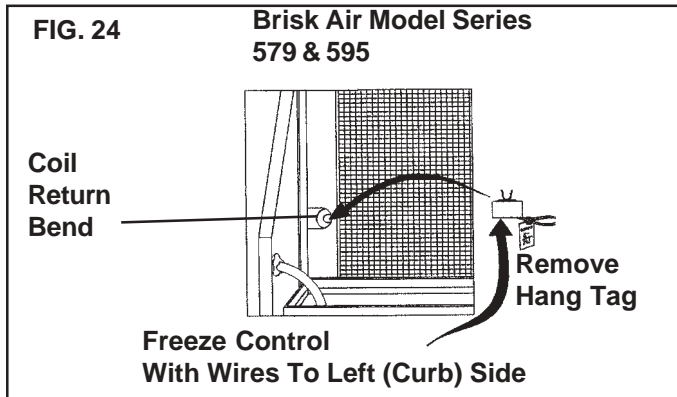

control. See FIG. 24.

- i. Position the electrical box towards the front of the opening with all of the system control wires connected to the control box except for the DC power. See FIG. 23.
2. Installing Foam Divider

- a. Locate the foam divider and insert it corner to corner in the 14-1/4" x 14-1/4" ( $\pm 1/8$ ") opening with the adhesive tape up. (Do not remove paper to expose adhesive). The foam divider should be level with the ceiling ( $\pm 1/4$ "). Tear off the excess at the pre-cut perforations in divider.

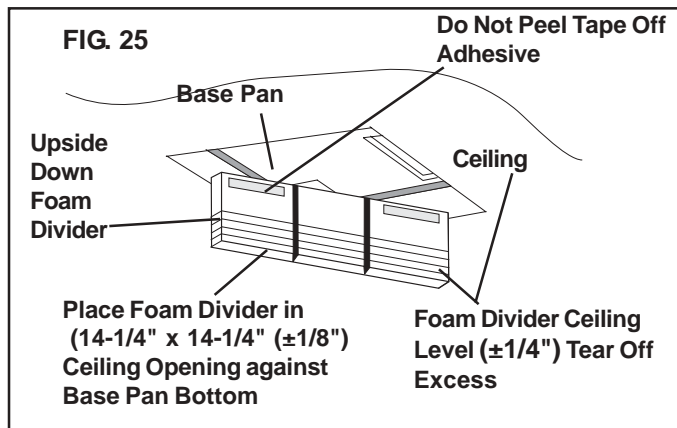

See FIG. 25.

- b. Peel the paper off of the foam divider and stick it in place on the center of the rear flange of the return air opening on the ceiling template. See

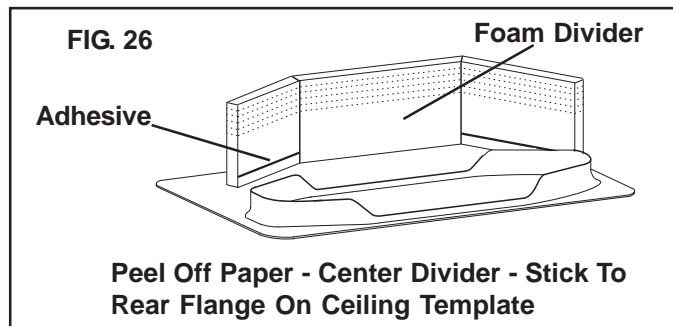
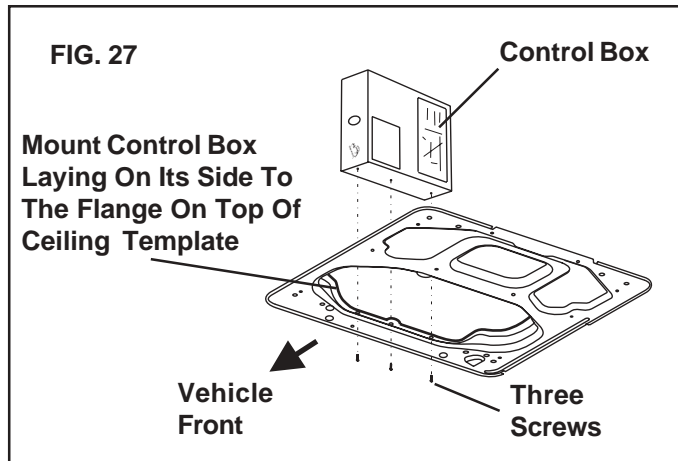

FIG. 26.

3. Mount the relay box laying on its side to the front flange of the ceiling template with blunt self-tapping



screws. See FIG. 27.

4. Start each mounting bolt through the ceiling template and up into the unit base pan by hand. **Evenly tighten mounting bolts to compress gasket to**

**CAUTION**

**If bolts are left loose there may not be adequate roof seal or if over tightened, damage may occur to the air conditioner base or ceiling template. Tighten to specifications listed in this manual.**

1/2" this will be a torque of 40 - 50 inch pounds.

- Use Aluminum foil tape (not supplied) to seal the ends of the foam divider to the sides of the opening. Make sure the area behind the flange on the ceiling template is sealed. See FIG. 28.

### CAUTION

Improper installation and sealing of foam divider will cause the compressor to quick cycle on the cold control. This may result in fuse or circuit breaker opening and/or lack of cooling.

**FIG. 28** Use Aluminum Foil Tape To Seal the Foam Divider To The Sides of 14-1/4" x 14-1/4" ( $\pm 1/8$ ") Ceiling Opening

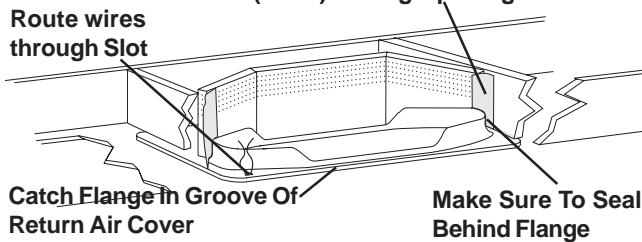

## H. Wiring The System

Reach up into the return air opening and pull the remaining wires down. See FIG. 29.

**FIG. 29**

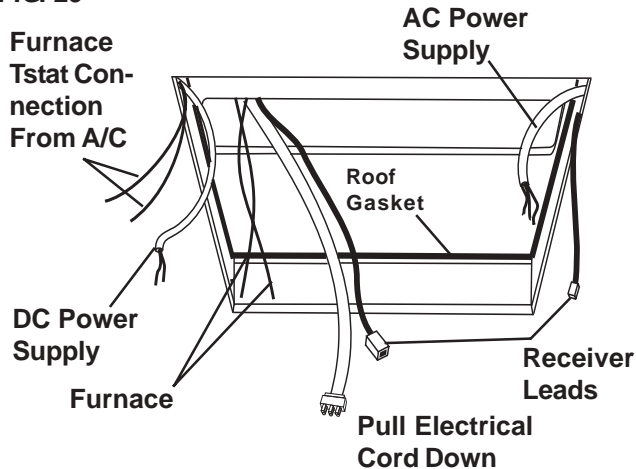

- Connection Of Low Voltage Wires

### CAUTION

Disconnect the positive (+) 12 volt DC terminal at the supply battery. Damage to equipment could occur if the 12 volt DC is not shut off.

**Note:** If solar panel is installed see instructions packaged with solar panel option.

**Note:** If using the Genesis Air Filtration System steps "a" and "b" are to be completed when installing the decorative cover.

- Connect the previously run 12 VDC to the red and black wires protruding from the units return air opening. Connect +12 VDC to the red wire; -12 VDC to the black wire. (Do not connect wires if using the 3308120 Genesis Air Filtration System Return Air Kit.) See Section I Decorative Cover Installation (Installing unit with 3308120 Genesis Filtration System Return Air Kit).
- Connect the previously run furnace thermostat wires (if applicable) to the blue/white wires protruding from the units return air opening. The polarity of these connections does not matter.
- Connect the receiver flat four conductor receiver cable previously terminated (see Section E-2. Receiver cable) into one of the receiver leads out of the air conditioner. Either one of the two (2) receiver cables can be used.
- Insert the receiver cable into the receiver and mount it in the desired location. See FIG. 8A, 8B, 8C and 30.

**FIG. 30**

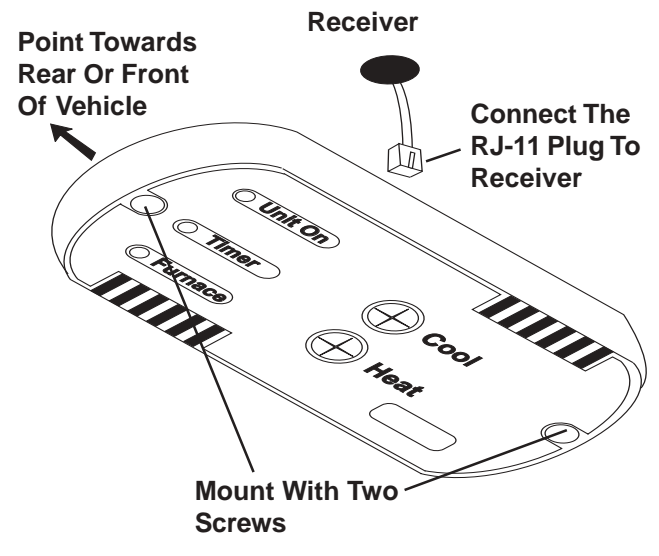

- Connection Of 115 Volt Power Supply

### WARNING

Disconnect 115 volt AC. Failure to follow these instructions could create a shock hazard causing death or severe personal injury.

- Route power supply line through Romex connector into junction box on side away from the ceiling template. Tighten connector, being careful not to pinch or short wires.

**⚠ WARNING**

This product is equipped with a 3-wire (grounded) system for protection against shock hazard. Make sure that the product is wired into a properly grounded 115 volt AC circuit and the polarity is correct. Failure to do so could result in death, personal injury or damage to the equipment.

- b. Connect white to white; black to black; and green to green or bare copper wire using appropriate sized twist connectors.
- c. Tape the twist wire connectors to the supply wire to assure they don't vibrate off.
- d. Push the wires into the box.
- e. Install the cover onto the junction box.

**I. Decorative Cover Installation**

- Installing unit with 3105007 or 3105935 Return Air Cover. For Genesis Air Filtration System Return Air Kit see page 15.

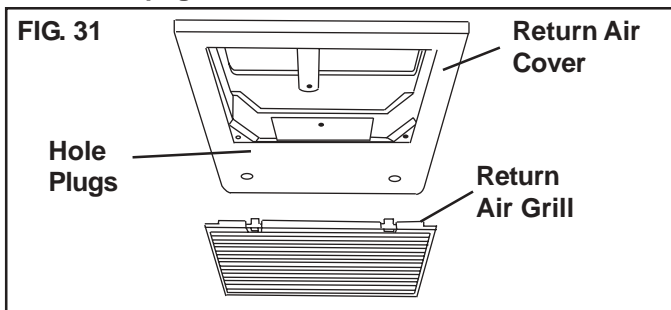

**Note:** On models equipped with a solar panel, see wiring instructions for the solar panel before proceeding.

1. Remove the return air grill from the return air cover.
2. Place the return air cover up to the ceiling template.
3. Install cover to template with #8 x 3/8" blunt point Phillips head screws provided (6 required).
4. Reinstall filter return air grill into return air cover. Align tabs with mating notches and snap into place.
5. Install two hole plugs into screw holes in back of return air cover. See FIG. 31.
6. This completes the installation of the air conditioner. We recommend that power be supplied to the air conditioner and check for proper operation. See section "J. Configuration Of Remote" and refer to Operating Manual or User's Guide for a description of the air conditioner operation.

- Installing unit with 3308120 Genesis Air Filtration System Return Air Kit. For 3105007 or 3105935 Return Air Kit See Page 15.

**Note:** On models equipped with a solar panel, see wiring instructions for the solar panel before proceeding.

1. Install the slider in the return air cover and raise it to the ceiling template. See FIG. 32.

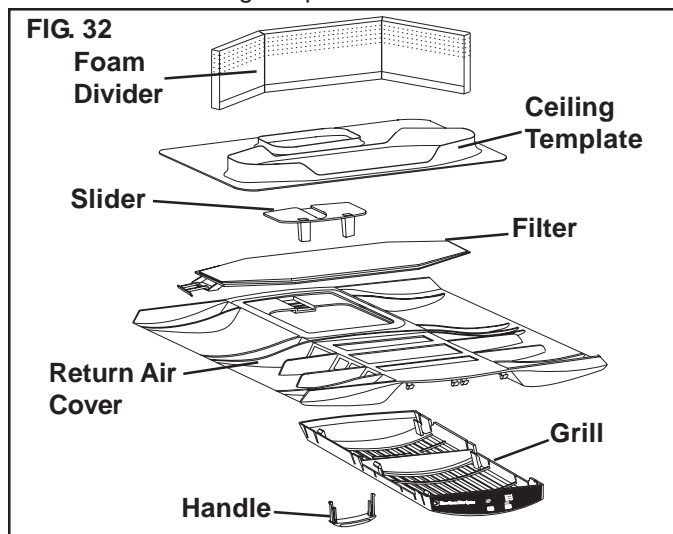

2. Route the wires from the return air cover through the template slot leaving about 3" between, and position wire here so they can be reached after plastic cover is installed. See FIG. 28.
3. Place the front of the return air cover against the ceiling and slide towards the rear. The flange on the ceiling template will catch in the groove on the return cover. Adjust the position (right to left) and install the front two screws. Start and tighten the remaining screws to hold it in place.
4. Connect together the wires from the thermostat, control box and filter indicator.

**Note:** If solar panel is installed see instructions packaged with solar panel option.

- a. Connect the red wire from the air conditioner and the red wire from the filter indicator light with the red positive 12VDC supply wire. See FIG. 28.
- b. Connect the black wire from the air conditioner and the black wire from the filter indicator light with the black negative 12VDC supply wire. See FIG. 28.

**Note:** Number 10 cabinet screw can be used to replace the two front screws to hold the plastic cover flush to the ceiling, if required.

5. Tighten the screws holding the return air cover. Slide the filter from the right side (looking toward the RV front) over the wires. Make sure the wires are secured above the filter and are out of its way.
6. Place grill on return air cover and snap in place. Decal is on end over circuit board.
7. Place slide handle through slots in grill into the slide posts. Handle will fit in either direction.

- This completes the installation of the air conditioner. We recommend that power be supplied to the air conditioner and check for proper operation. See section "J. Configuration Of Remote" and refer to Operating Manual or User's Guide for a description of the air conditioner operation.

- Cool/furnace** operation: Dip switches 1,2,& 3 "ON" - dip switch 4 "OFF".
- Cool Only**-no heat operation: Dip switch 1 & 3 "ON" - dip switches 2 & 4 "OFF".
- Cool/Heat** operation: Dip switches 1,2,3, & 4 "ON" -no dip switches "OFF".

**Note:** After the remote switches are changed, point remote at the receiver and press the reset button.

**J. CONFIGURATION OF REMOTE**

The Hand Held Remote when shipped from Dometic is always programmed as a cool/furnace model. The dip switches are located in the hand held remote battery compartment. See FIG. 33. If the control is to be used with the electric heat strip or without the furnace its configuration must be changed as follows:

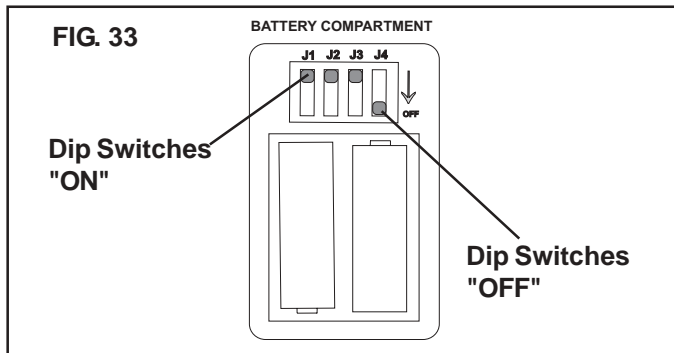

**UNIT FIELD WIRING DIAGRAM**

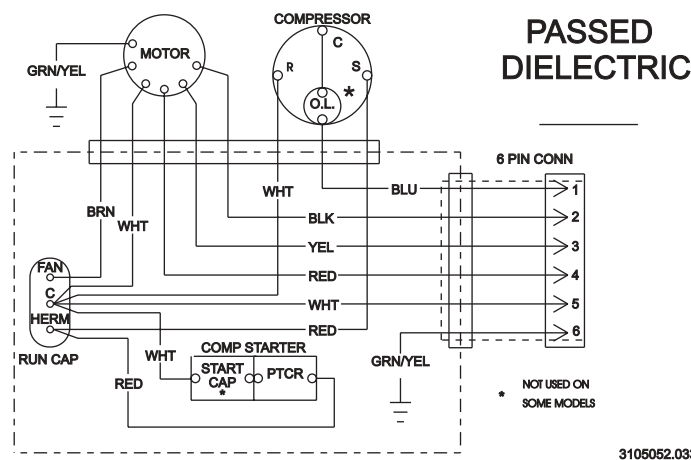

3105052.033

### 3308417.009 FIELD WIRING DIAGRAM

3308603.012  
 - - - - - FIELD WIRING  
 \_\_\_\_\_ FACTORY WIRING  
 • LINE SPLICE

**Duo-Therm**® 509 S. POPLAR ST.  
 LAGRANGE, IN 46761  
 115VAC, 60Hz, 1 Ø

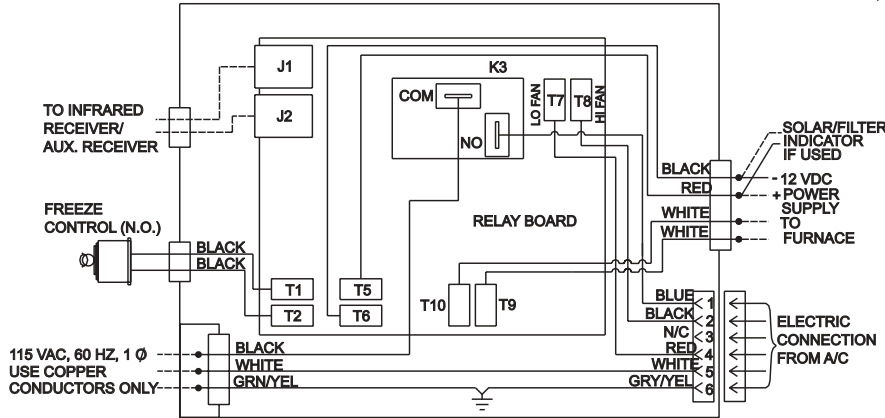

PART No. 3308448.004  
 SERIAL No.  
 FOR USE WITH AIR CONDITIONER:  
 579, 595  
 WITHOUT HEAT STRIP OPTION

**PASSED  
 DIELECTRIC**

### 3308417.025 FIELD WIRING DIAGRAM

3308604.010  
 - - - - - FIELD WIRING  
 \_\_\_\_\_ FACTORY WIRING  
 • LINE SPLICE

**Duo-Therm**® 509 S. POPLAR ST.  
 LAGRANGE, IN 46761  
 115VAC, 60Hz, 1 Ø

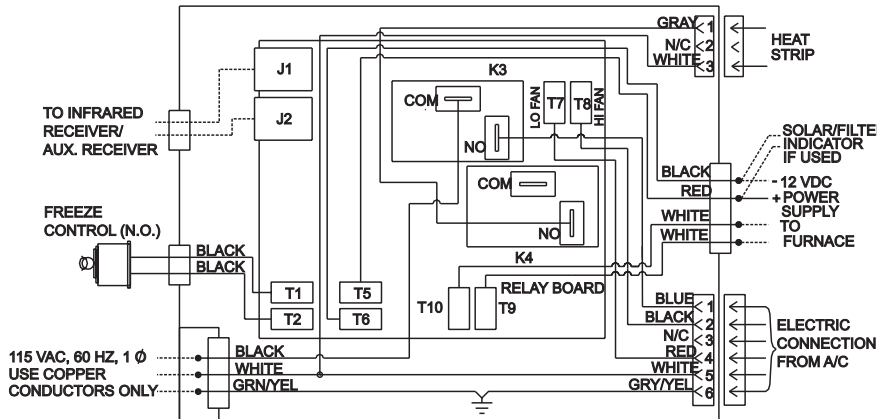

PART No. 3308448.020  
 SERIAL No.  
 FOR USE WITH AIR CONDITIONER:  
 579, 595  
 WITH OPTIONAL HEAT STRIP

**PASSED  
 DIELECTRIC**