



# INSTALLATION INSTRUCTIONS

## HEATING EQUIPMENT

## RECREATIONAL VEHICLE UNDER-COUNTER FURNACE MODELS 4016-4023-4030

Model No.	Code No.	Electrical Supply	A.G.A. Rating at Sea Level, Btu/hr*		Gas Connection Size	DIMENSIONS (See Figures 1 and 2)								CLEARANCES						
			Input	Output		A	B	C	D	E	F	G	H	J	K	L	Sides	Top	Bottom**	Rear
4016	789	115VAC/12VDC	16,000	12,800	3/8 SAE	15	15	23	3/4	1 1/4	1 1/4	1 1/4	7/8	3-7/16	3-7/8	4-15/16	0"	0"	0"	0"
	889	12VDC																		
4023	789	115VAC/12VDC	23,000	18,400	3/8 SAE	15	15	23	3/4	1 1/4	1 1/4	1 1/4	7/8	3-7/16	3-7/8	4-15/16	0"	0"	0"	0"
	889	12VDC																		
4030	789	115VAC/12VDC	30,000	22,500	3/8 SAE	15	17	23	3/4	1 1/4	1 1/4	1 1/4	1-1/8	3-5/16	3-7/8	4-15/16	0"	0"	0"	0"
	889	12VDC																		

\*For elevations above 2,000 feet, reduce input rate by 4% for each 1,000 feet of elevation above sea level.

\*\*When installed on in-floor duct systems, use special connector 4023-5331.

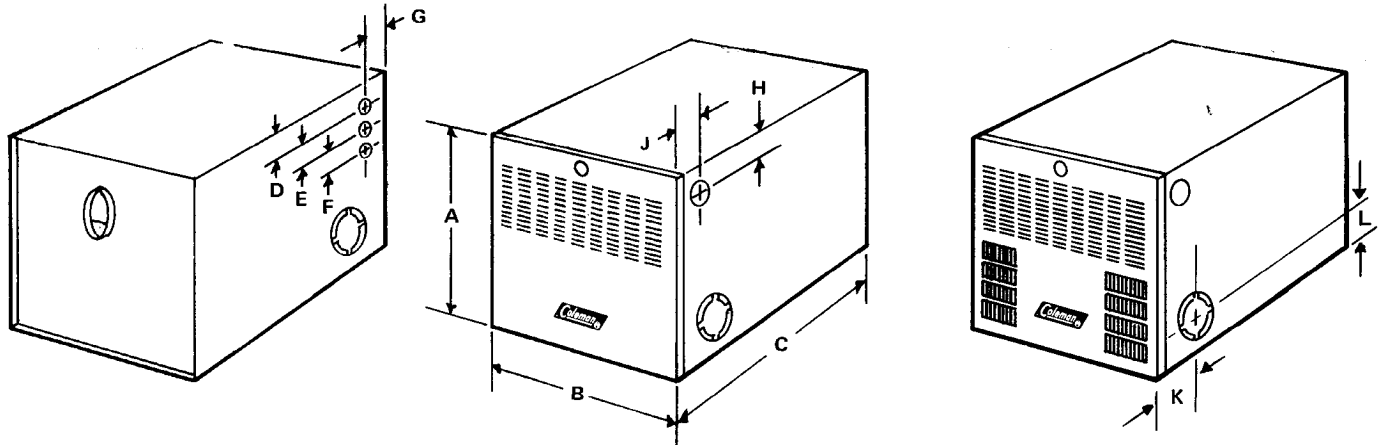

Figure 1

Reference Figure for Models 4016 and 4023

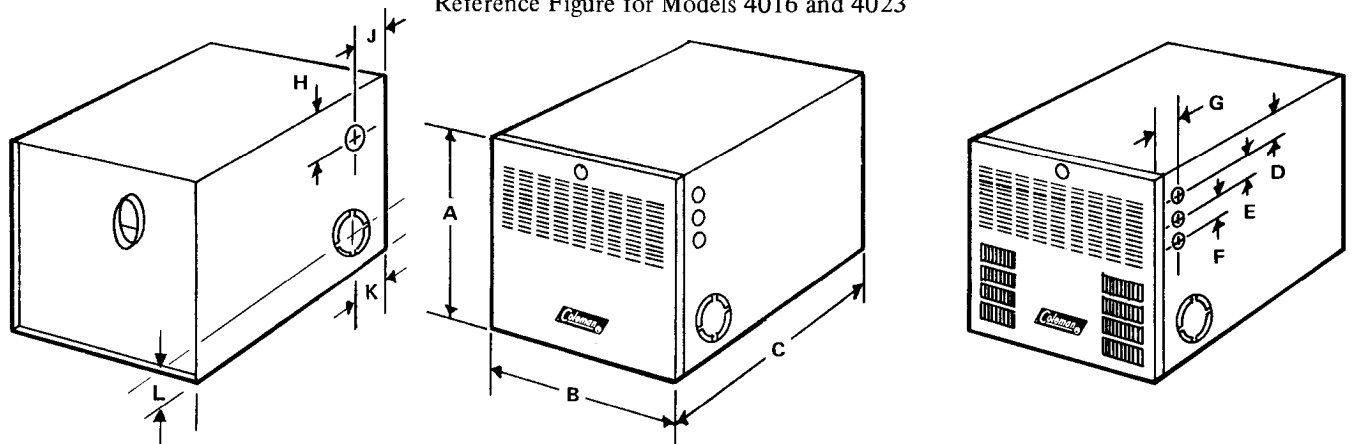

Figure 2

Reference Figure for Model 4030

# INSTALLATION INSTRUCTIONS



## DESCRIPTION

These furnaces have been listed for safety and performance by the American Gas Association for installation in mobile homes and travel trailers. Primarily, they are designed for use in motor homes and recreational vehicles. They are of sealed combustion system design with sectional-type heat exchangers consisting of drawn steel sections welded together. The burner, designed for use with LP gas, is of cast iron construction with slotted ports and a means of air adjustment provided.

These units feature 100% safety shut-off gas controls and manual electric ignition. Depending on the model code, they may be operated either from 115V AC or 12V DC power sources (see front page).

A small flush vent has been developed for these furnaces and can be installed through walls ranging in thickness from 1 inch to 4 inches.

Provisions have been made for installation on any one of the following air distribution systems:

1. Side duct system,
2. Floor duct system, and
3. Front discharge system (no ducts).

For side and floor duct systems, the units have been listed by the American Gas Association for use as Horizontal Sealed Combustion System **Forced Air Furnaces**. For a front discharge system (no ducts), the units have been listed for use as Fan Type Sealed Combustion System **Wall Furnaces**.

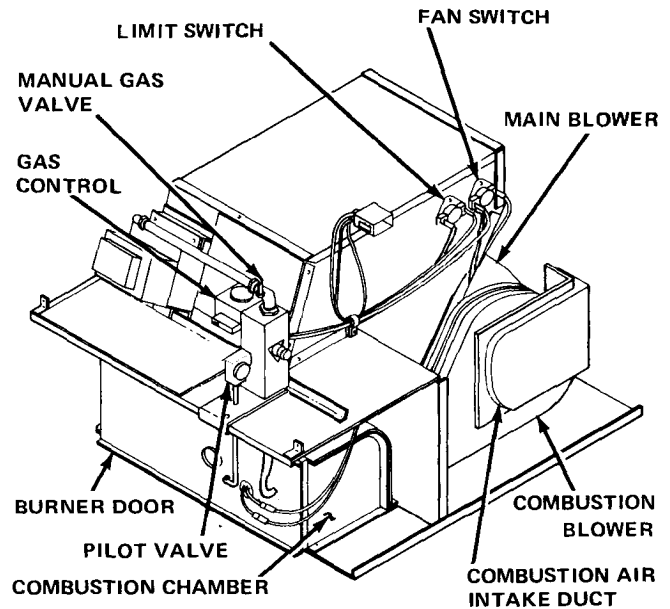

Figure 4  
Heat Unit Assembly for Model 4030

The type of front louvered panel that is used is the distinguishing factor in determining whether the unit is a forced air furnace or a wall furnace. For example, for a forced air furnace application see the following table:

Model Number	Front Panel Number
4016	4023-5871
4023	4023-5871
4030	4030-5871

TABLE 1—Front Louvered Panels Required for Forced Air Furnace Applications

When the unit is installed for use as a wall furnace, the following front panels are used:

Model Number	Front Panel Number
4016	4023-5881
4023	4023-5881
4030	4030-5881

TABLE 2—Front Louvered Panels Required for Wall Furnace Applications.

Basically, all models described herein are similar and the method of installation generally is the same.

The compact design of the unit will permit installation in minimum space requirements; for example, under cabinets or built-in appliances.

The working parts of the furnace, called the heat unit assembly, have been mounted on a sliding tray which can be removed from the outer casing for servicing. SEE FIGURES 3 and 4.

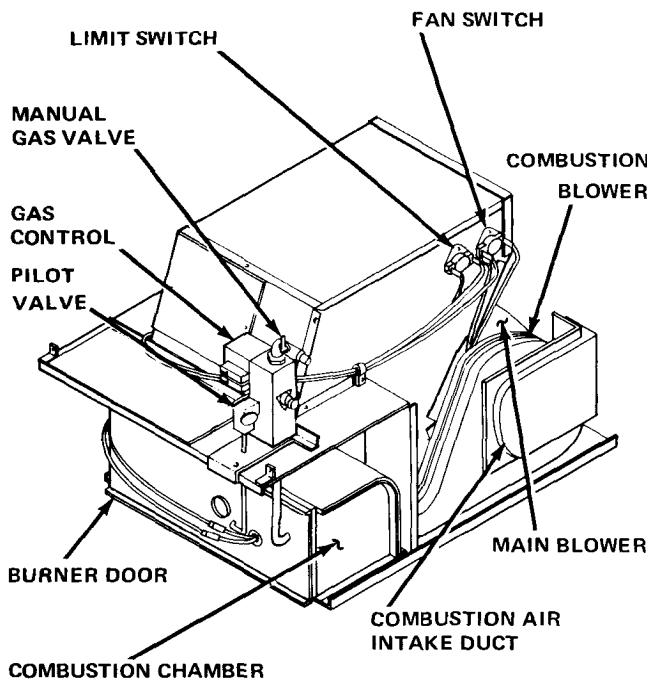

Figure 3  
Heat Unit Assembly for Models 4016 and 4023

## INSTALLATION INSTRUCTIONS

Basically, there are three possible methods of installation. These methods differ only in the type of air distribution system used (for example; side ducts, floor duct, or front discharge with no ducts). The minimum space requirement, regardless of type of air distribution system, for installation of the various models of furnaces are as follows:

Model No.	Height	Width	Depth
4016	15	15	23
4023	15	15	23
4030	15	17	23

### A. Procedure for Side Duct Installation:

1. When a side discharge installation is desired, the minimum recommended duct size is 4 inches inside diameter. Select a location for the furnace on an outside wall as near the center of the vehicle as possible.

#### NOTE:

If the furnace must be located at one end of the supply duct, use the bottom discharge so that a minimum duct size of 3½" x 12" can be maintained.

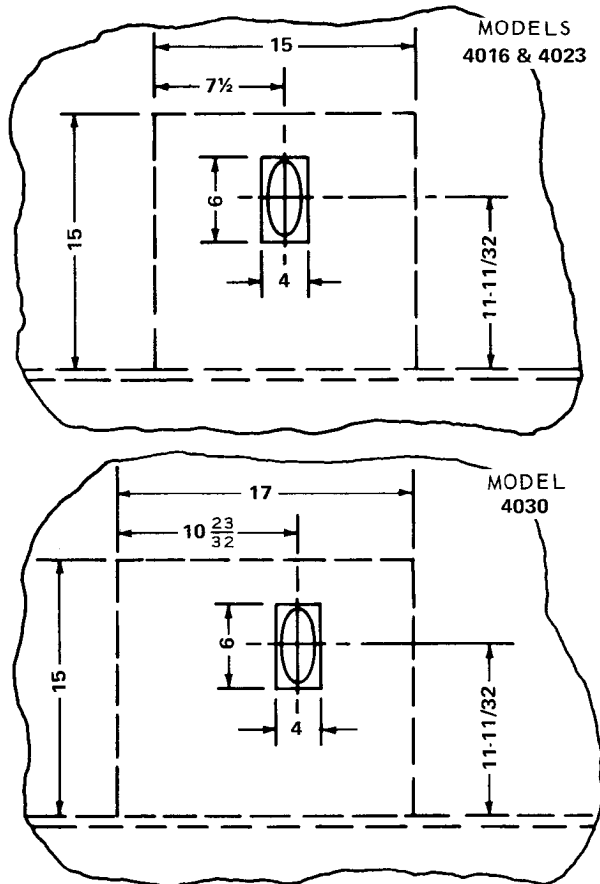

Figure 5  
Location of Vent Opening

2. Refer to Figure 5 and cut a 4" x 6" opening through the inner and outer walls of the vehicle.
3. Position the heater flush with the inside wall of the vehicle so that the elliptical connector on the back of the furnace aligns with the 4" x 6" opening made in step 2 above. Secure the unit to the floor, as shown in Figure 6.
4. Remove the two round side knockouts from the furnace inner casing.

#### NOTE:

DO NOT REMOVE BOTTOM KNOCKOUT.

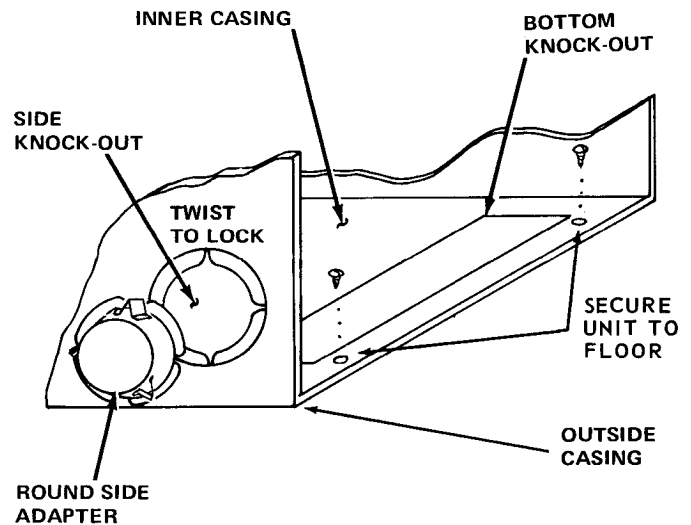

Figure 6  
Installation of Round Side Adapters

5. When the unit is installed for side discharge operation, it is recommended that the duct size be no smaller than 4 inches in diameter. Provision has been made for a quick-connect round side adapter for ease in connecting the 4-inch diameter ducting to the furnace. The quick-connect adaptor is a twist-on device and is installed as demonstrated in Figure 6. Only 1/8 of a turn is required for locking and sealing.
6. Refer to Figure 7 for an illustration of a typical side duct installation complete. Be sure to use discharge registers having a minimum of 20 square inches total free area.
7. Install the vent terminal on the outside wall of the vehicle as shown in Figure 8.

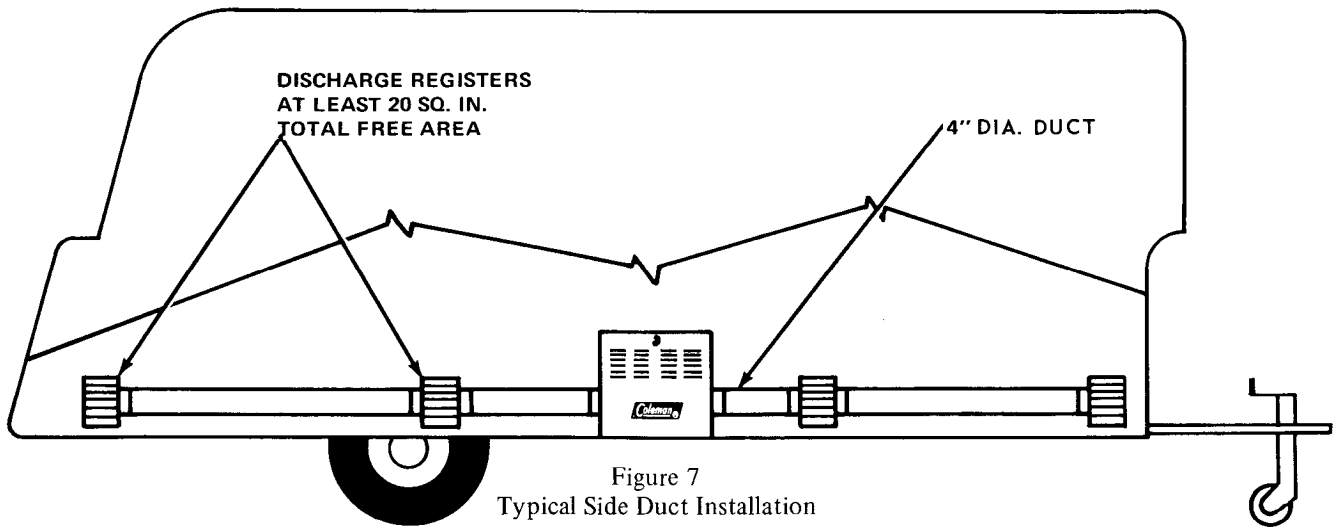
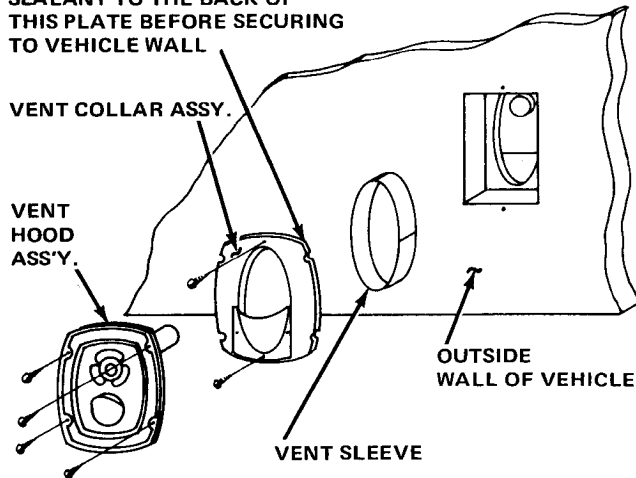

Figure 7  
Typical Side Duct Installation

APPLY MASTIC OR PERMAGUM SEALANT TO THE BACK OF THIS PLATE BEFORE SECURING TO VEHICLE WALL



All furnaces are provided with a standard vent sleeve for 2-inch wall thicknesses. Optional sleeves are available for wall thickness of 1 inch and 4 inches.

Figure 8  
Exploded View of Vent Assembly

## B. Procedure for Floor Duct Installation:

1. Select a location for the furnace on an outside wall as near the center of the vehicle as possible.
2. Refer to Figure 5 and cut a 4" x 6" opening through the inner and outer walls of the vehicle.
3. Remove the bottom knockout from the furnace inner casing.

## NOTE:

DO NOT REMOVE SIDE KNOCKOUTS.

4. Position the heater flush with the inside wall of the vehicle so that the elliptical connector on the back of the furnace aligns with the 4" x 6" opening made in step 2 above.
5. With the furnace in this position, remove the front louvered panel and mark the location of the front edge and sides of the knockout on the floor. Remove the furnace, and using the floor lines as a guide, complete the back edge of the rectangle making it 3½" x 12". Before cutting through the floor, enlarge this marked opening by 1" all around, making it 5½" x 14". Cut through the floor at this point. See Figure 9(a) or 9(b) for the dimensions locating the floor cutout.
6. Cut a 3½" x 12" hole in the metal duct under the floor, centered in the floor opening.
7. Lay furnace on side and install the floor thimble. Installation of the floor thimble is demonstrated in Figure 9(c).
8. Place the furnace with floor thimble attached over the floor opening and position so that the tabs on the thimble extend downward into the underfloor duct. From inside the furnace bend tabs under to secure the thimble to the duct. **(The unit must be secured to the floor. See Figure 6.)**
9. Refer to Figure 10 for an illustration of a typical floor duct installation complete. Be sure to use discharge registers having a minimum of 20 square inches total free area.

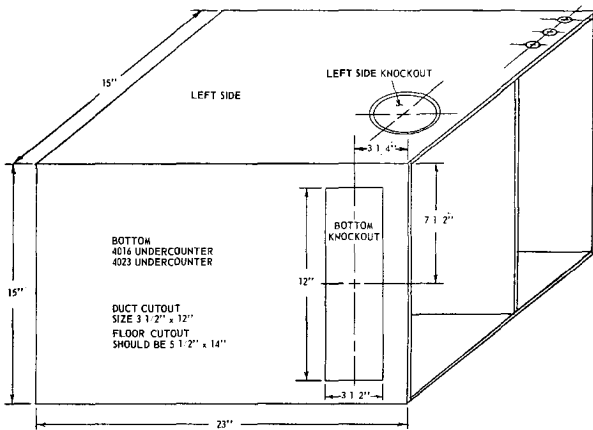

Figure 9(a)

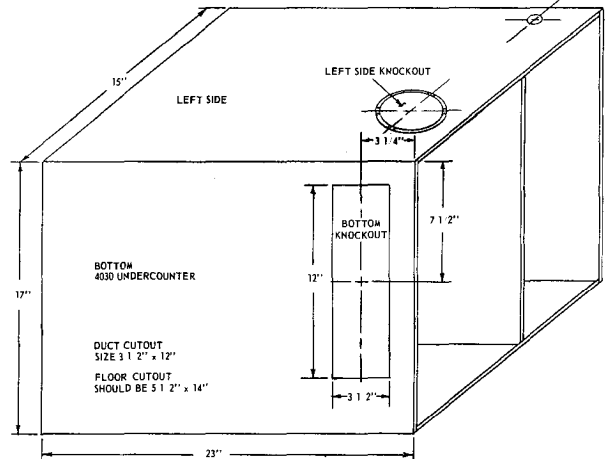

Figure 9(b)

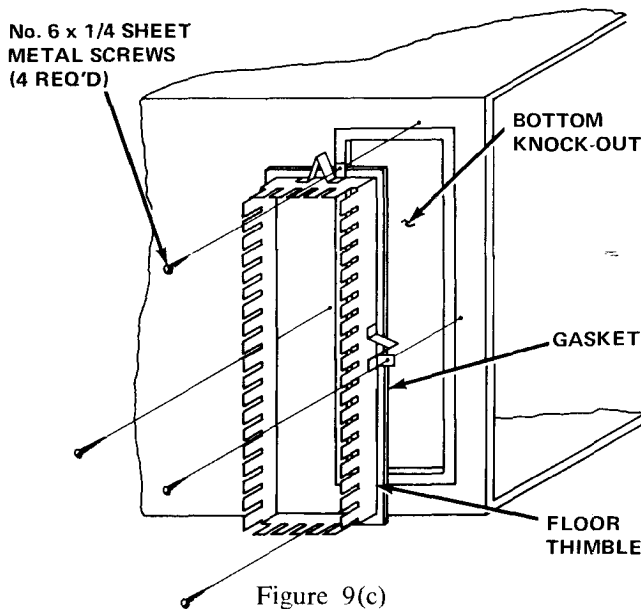

Figure 9(c)  
Installation of Floor Thimble  
4016, 4023 Shown

10. Install the vent terminal on the outside wall of the vehicle as shown in Figure 8.

**C. Procedure for Ductless Installation (Front Discharge)**

1. Select a location for the furnace on an outside wall as near the center of the vehicle as possible.
2. Refer to Figure 5 and cut a 4" x 6" opening through the inner and outer walls of the vehicle.
3. Position the heater flush with the inside wall of the vehicle so that the elliptical connector on the back of the furnace aligns with the 4" x 6" opening made in step 2 above. Refer to Figure 11 and make certain that the minimum clearances to ceiling and side walls are maintained as shown. Secure the unit to the floor. See Figure 6.

4. DO NOT REMOVE ANY KNOCKOUTS FROM THE INNER CASING. Note that the top louvered section of the door is for return air flow and the louvers in the bottom section of the door are for warm air discharge.

5. Install the vent terminal on the outside wall of the vehicle as demonstrated in Figure 8.

**D. General Installation Procedures Pertaining to All Models.**

1. Gas Piping - The gas supply line to the furnace must be of adequate size to provide 11" water column gas pressure. This pressure must be maintained under maximum flow conditions with all gas appliances in operation. Tubing may be type "K" for LP gas (Bottle Gas). However, be sure to check with local authorities for any other requirements concerning gas piping. See note below.

Gas line hook-up on Models 4016 and 4023 furnaces is made through a hole provided at the top right side of the furnace casing. This connection is made at the top left side on Model 4030 furnace. Actual hook-up normally is accomplished inside the furnace casing immediately ahead of the manual shut-off valve. A 3/8 flare connection is provided for ease of installation.

**CAUTION:** Do not twist gas valve during piping.

**NOTE:**

Local codes may require installation of an external manual shut-off valve. If required, the manual valve must be located outside the confines of the furnace casing.

After connections have been made, be sure all joints are checked with soap solution to detect leaks. This also should include a check of the furnace controls and piping. **NEVER CHECK FOR LEAKS WITH A LIGHTED MATCH.**

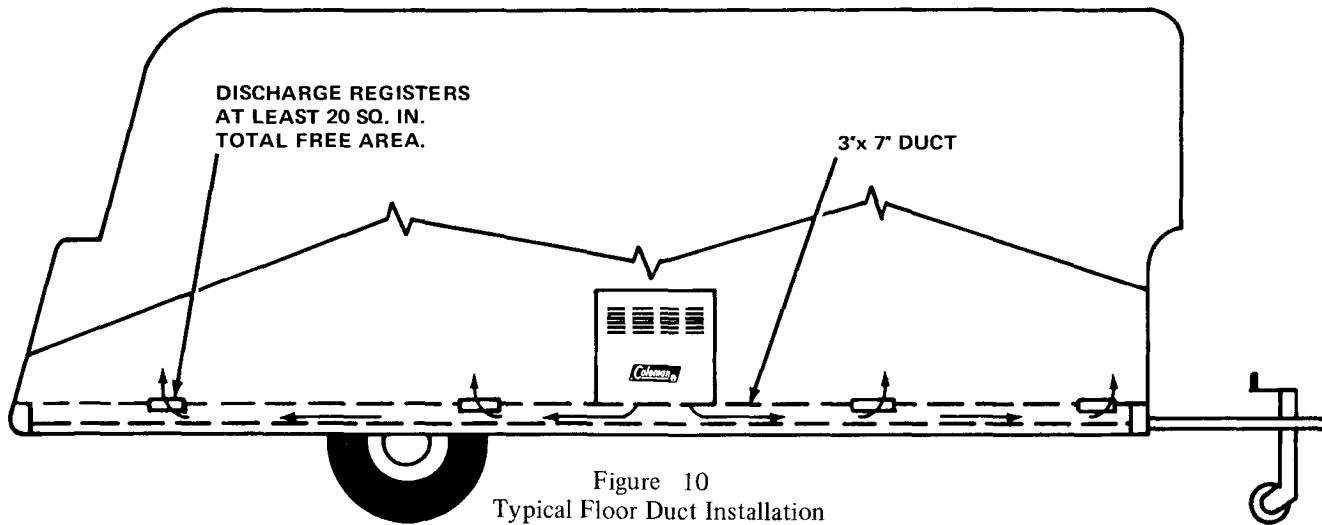

Figure 10  
Typical Floor Duct Installation

2. Electrical Connections —

**WIRING CAUTION:**

**POLARITY** must be observed when connecting a battery or external converter to the furnace terminal board.

Connect **PLUS (+)** of battery or external converter to **PLUS (+)** on terminal board. Connect **NEGATIVE (-)** of battery or external converter to **NEGATIVE (-)** on terminal board.

If polarity is reversed, the blower will turn **BACKWARD** and the furnace **WILL NOT** heat.

The furnace wiring box contains provisions for all wiring connections. The wiring box is located directly behind the return air grille in either the top left front or top right front of the furnace casing, depending on model number. See Figure 12. The same terminal board is used on both multivoltage and DC models. Consequently, on straight DC models the 115V AC terminals have no usage.

potential test on this furnace. Testing has been done before leaving the factory. If vehicle Hi-Pot testing is required, disconnect the furnace before testing. If the furnace contains a power converter, **DO NOT ATTEMPT TO CHECK IT OUT BY SHORTING TO GROUND. DO NOT DISCONNECT ANY POWER LEAD AND SHORT TO GROUND.** Any shorting or arcing of the leads may damage the furnace components.

Circuit breakers, where applicable, shall be sized in accordance with the National Electrical Code. Local codes, where applicable, take precedence over these recommendations. Route the supply wiring and thermostat wiring through the knockouts and secure to the terminal board. Use a suitable connector to secure supply wires at the knockouts. Do not use wire size smaller than that indicated in Table 3.

**NOTE:**

For continued satisfactory performance of this unit, it is necessary that the control compartment be kept clean.

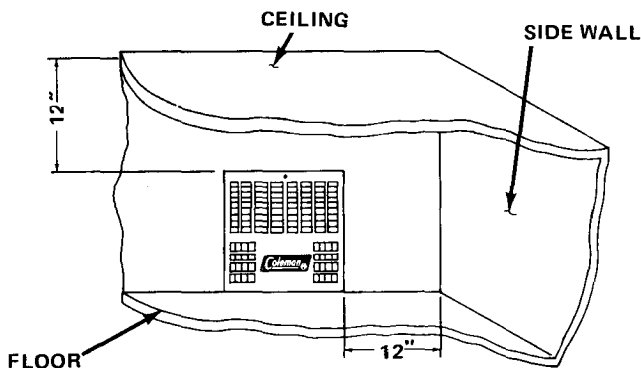

Figure 11  
View Showing Minimum Clearance to Side Walls and Ceiling for Wall Furnace Application

Knockouts for AC wiring, DC wiring, and the thermostat wiring are provided at the wiring boxes. **CAUTION:** Do not perform any high

CIRCUITRY	RECOMMENDED WIRE SIZE
115V A.C.	No. 14 AWG
12V D.C.	No. 14 AWG
Thermostat	18 gauge solid or stranded copper with 2/64 insulation.

Table 3  
Recommended Wire Sizes

If the chassis of the vehicle is used as a ground return path for the DC supply circuit, all metal components must be bonded or electrically connected to allow current flow. Grounding should be made only through the negative (-) side of the DC circuit.

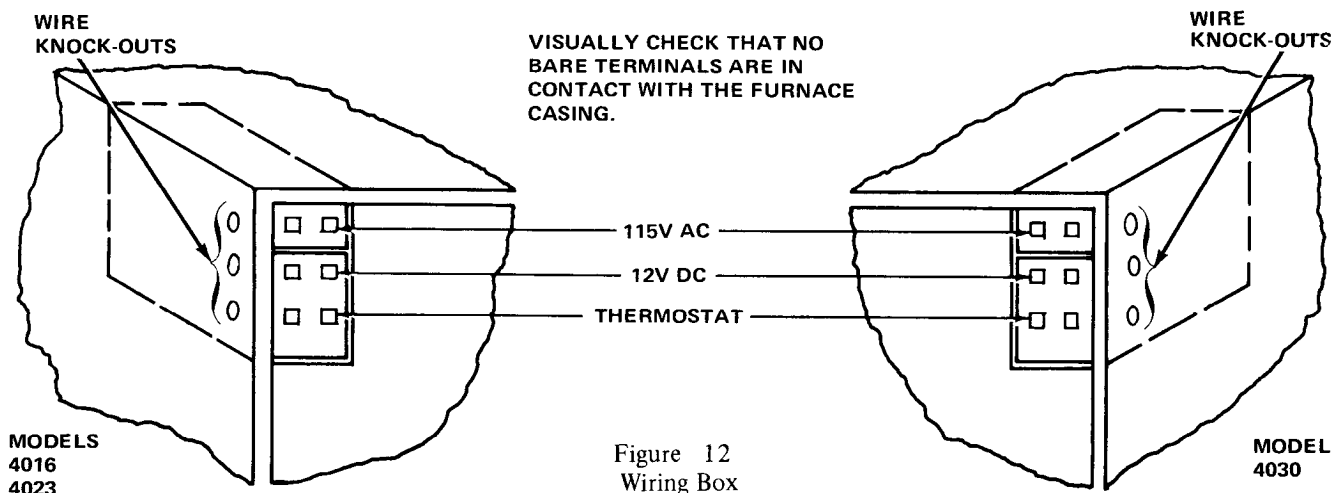

MODELS  
4016  
4023

MODEL  
4030

3. Thermostat Installation — Your furnace is equipped with room thermostat. Locate the thermostat on an inside wall at least four feet from the floor. Select a location where the air circulation is good. Do not locate on an outside wall, near a door or window, near heat source such as lamps, etc., in direct sunlight or any surface subject to vibration during operation.

To connect the thermostat to the furnace, run two wires from the thermostat to the furnace terminal board. See Figure 12.

### OPERATIONAL CHECKOUT

1. Remove front panel on furnace by turning knob counter-clockwise, pulling out and up.
2. Turn on gas supply at LP bottle. Turn main gas valve and pilot valve on "ON" positions.
3. Turn thermostat to lowest possible temperature setting.
4. Set main switch to correct power supply. See the "Operation and Service Instruction" pamphlet.
5. Depress red button on right side of control body as far as possible. Glow coil will be observed through observation window.
6. Continue to "hold in" red button for one minute after pilot flame is established or until pilot flame remains lighted after button is released. If necessary, pilot flame may be adjusted by removing the cap screw in the center of the pilot valve and rotating the underlying screw counterclockwise for higher flame or clockwise for lower flame.
7. Replace front panel.
8. Set wall thermostat to desired setting. Furnace now will operate automatically.

### NOTE:

If the igniter coil should fail for any reason, the pilot may be lighted manually as follows:

- (a) Turn thermostat to lowest possible temperature setting.
- (b) Remove observation window and allow furnace to set for approximately 5 minutes to dissipate any gas that may have accumulated in the combustion chamber.
- (c) Fix match in lighter rod provided with the furnace.
- (d) Light match and insert into pilot area through window while depressing red button.
- (e) Hold in red button for one minute after pilot is ignited.
- (f) Replace window.
- (g) Replace front door.
- (h) Set thermostat to desired temperature setting. Furnace now will operate automatically.

### SHORT CIRCUIT CHECKOUT

If fuses are blown either in the furnace or vehicle, a short is indicated and should be checked.

1. Turn off all appliances including furnace.
2. Install an ammeter on the positive (+) lead of the battery. Amperage reading should be 0. If an amperage reading is noted, a short exists in the vehicle electrical system.
3. Disconnect the red (+) DC lead at the furnace. If the amperage continues, the short is exterior to the furnace. If the amperage reading ceases, the furnace electrical system is shorted and should be checked.
4. Refer to the Operation and Service Instructions for a complete checkout.

# INSTALLATION INSTRUCTIONS

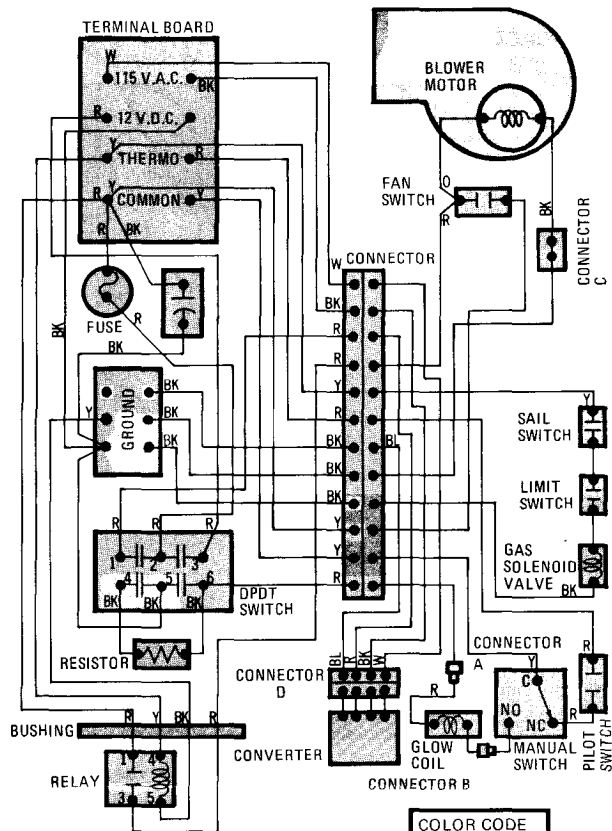

ALL FACTORY INSTALLED WIRING IS STRANDED 16 AND 18 GA. SINGLE CONDUCTOR, 105 C THERMOPLASTIC INSULATED WIRE U.L. AND C.S.A. APPROVED IF ANY OF THE ORIGINAL WIRE AS SUPPLIED WITH THE APPLIANCE MUST BE REPLACED, IT MUST BE REPLACED WITH TYPE AWM 105 C WIRE OR ITS EQUIVALENT.

COLOR CODE	
R	- RED
BL	- BLUE
Y	- YELLOW
O	- ORANGE
BK	- BLACK
W	- WHITE

Replacement Fuses		
4016	MDL 6	Must Be Buss or Equivalent
4023	MDL 9	Slow Blow Type

## MULTIVOLTAGE UNIT WIRING DIAGRAM

MODELS  
4016-789  
4023-789  
4030-789

**The Coleman Company, Inc.**

250 NORTH ST. FRANCIS AVENUE  
WICHITA, KANSAS 67201

1970-533 5-71 D.L.

LITHO IN U.S.A.

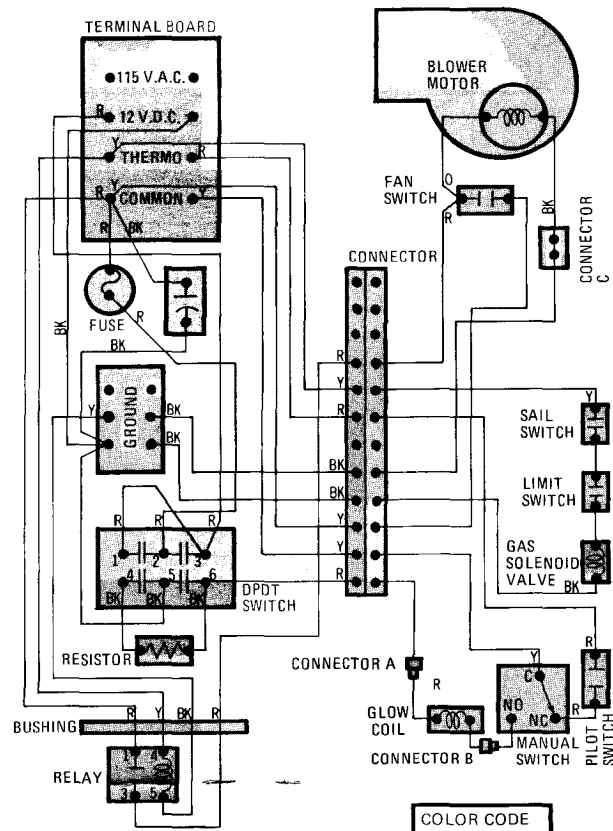

ALL FACTORY INSTALLED WIRING IS STRANDED 16 AND 18 GA. SINGLE CONDUCTOR, 105 C THERMOPLASTIC INSULATED WIRE U.L. AND C.S.A. APPROVED IF ANY OF THE ORIGINAL WIRE AS SUPPLIED WITH THE APPLIANCE MUST BE REPLACED, IT MUST BE REPLACED WITH TYPE AWM 105 C WIRE OR ITS EQUIVALENT.

COLOR CODE	
R	- RED
BL	- BLUE
Y	- YELLOW
O	- ORANGE
BK	- BLACK
W	- WHITE

Replacement Fuses		
4016	MDL 6	Must Be Buss or Equivalent
4023	MDL 9	Slow Blow Type

## DC UNIT WIRING DIAGRAM

MODELS  
4016-889  
4023-889  
4030-889

**The Coleman Company, Inc.**

250 NORTH ST. FRANCIS AVENUE  
WICHITA, KANSAS 67201

1970-534 5-71 D.L.

LITHO IN U.S.A.

**The Coleman Company, Inc.**

1970B617 1/72 DONLEVY

WICHITA, KANSAS 67201

LITHO IN U.S.A.



Manual provided courtesy  
Bryant RV Services  
[www.byantrv.com](http://www.byantrv.com)

All manuals are believed to be released for distribution, and/or in the public domain.

Service manuals provided with the understanding that persons using them are well versed in proper safety practices, and are familiar with basic safety procedures, including, but not limited to safety procedures dealing with 120 volt electricity, high amperage 12 volt circuits and LPG (propane) systems.

If in doubt, consult a professional (better safe than sorry).