

Purpose

This service bulletin provides troubleshooting and service tips for the ice maker water solenoid valve and the ice maker.

Applicability

All Norcold gas/electric refrigerators with factory installed ice maker.

Background

The failure of the ice maker to eject ice cubes may be related to improper winterization or not winterizing the water solenoid valve. The customer reports that the ice maker:

- Is not making ice or will not eject the ice from the mold.
- Cycled a few times, then stopped ejecting the ice from the mold.

Indications

Visual indications may include:

- Icicles and ice formation on the sides of the ice maker and ice buildup on the surface of the freezer plate.
- Water overflowing the mold when the water solenoid valve is not energized.

Causes

The valve's water chamber (see Figure 1) always retains water. Leaving the garden hose fitting attached to the valve will allow more water to be retained in the valve. In ambient freezing temperatures, water retained within the valve will freeze. As the water freezes, it will tend to move the orifice, washer seal, and strainer out of place.

The strainer, which is normally recessed about 1/8 inch into the inlet (see Figure 1), provides the best clue for identifying a valve that has been subjected to freezing temperatures. The visual clue is a deformed strainer cup. (see Figure 2). The cup end of the strainer will be flush with the inlet fitting opening. In this position, when the ice maker cycles and energizes the water solenoid valve, the mold fill capacity will be exceeded. The normal mold water capacity is 4.7 fl. oz. (140 mL). The ice buildup in the valve's water chamber may also deform and unseat the washer seal. This will cause water to bypass the valve's seat and flow continuously into the mold.

As the excess water in the mold freezes over the formed ice cubes, it fuses the ice cubes into a single block of ice.

During the ice ejection cycle, the ejector blades cannot overcome the surface tension created by the layer of ice that is fusing the ice cubes into a single block of ice. This causes the ice maker motor oscillate continuously as it tries to overcome the surface tension imposed by the ice.

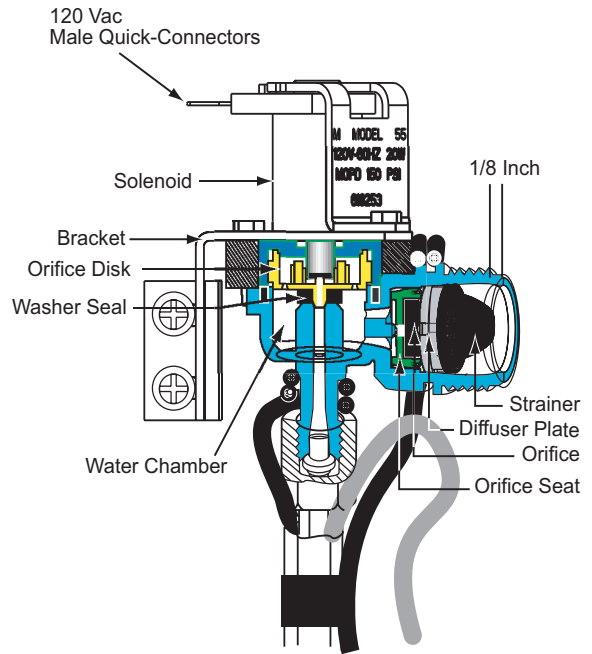

Figure 1. Ice maker water solenoid valve.

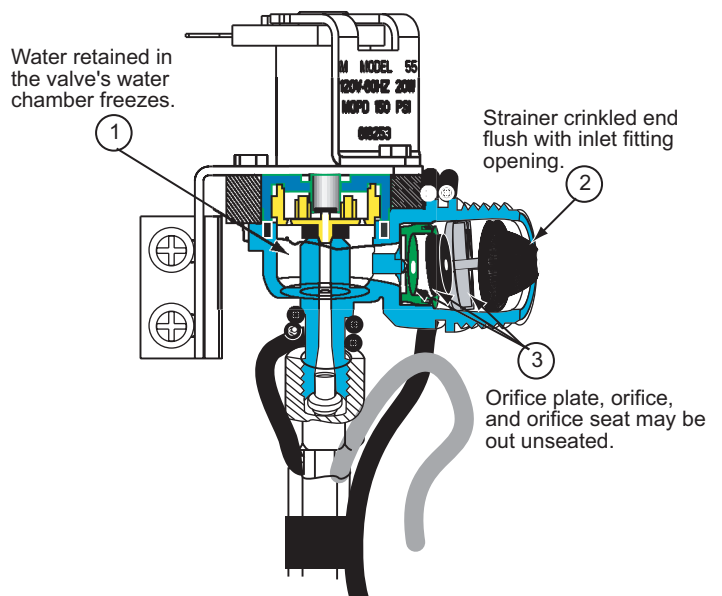

Figure 2. Components location after freezing.

How to Check the Position of the Strainer

If the valve froze, most likely the strainer, orifice plate, orifice, and orifice seat will be out of place. This will cause excessive water in the mold and the ice maker will fail to eject the ice cubes. The position of the cup end of the strainer is the best visual indication to determine if the valve have been tampered with or exposed to ambient freezing temperatures.

The normal position of the strainer is shown in Figure 1. If the components have been tampered with or the valve was exposed to ambient freezing temperatures most likely the strainer is in the position shown in Figure 2. To check the position of the strainer:

1. Shut off the water supply to the ice maker.
2. Disconnect the garden hose fitting to expose the cupped end of the strainer.
 - If the strainer end is seated approximately 1/8 inch in the inlet opening of the valve, the orifice seat, orifice, diffuser plate and strainer are in their correct position. Proceed to the Operational (cycle) Test, see page 3.
 - If the strainer end is crinkled and flush with the edge of inlet opening, most likely **the strainer, diffuser plate, orifice, and the orifice seat are out of position.**

How to Reposition the Orifice Seat, Orifice, Diffuser Plate and Strainer

To reposition the orifice seat, orifice, diffuser plate, and strainer in the inlet opening:

1. Carefully pull out the strainer with a small flat tip screwdriver. Use caution as not to pierce, crush, or damage the strainer.
2. Pull out the diffuser plate, orifice, and orifice seat.
3. Position the orifice seat, orifice, diffuser plate, and strainer as shown in Figure 3. When reassembling these components, always make sure:
 - The orifice seat is fully seated in place.
 - The orifice is fully seated in the orifice seat.
 - The back side of the diffuser plate is fully seated against the orifice.
 - The strainer is fully seated and there is approximately 1/8 inch gap between the end of the strainer and the inlet fitting opening.
4. Connect the garden hose fitting to the valve.
5. Reconnect the water supply line to the garden hose fitting.
6. Cycle the ice maker. See Operational (cycle) Test, page 3.

How to Check for a Damaged Washer Seal

If the water seal is damaged, water will drip continuously out of the valve's outlet fitting. To check the water solenoid valve for constant leakage:

1. Disconnect ice maker water supply line from the water solenoid valve outlet fitting.
2. Thoroughly dry the valve's outlet fitting.
3. Turn on the RV water supply to the ice maker.
4. Observe the outlet fitting for water leakage (dripping). Replace water solenoid valve if the water solenoid valve is leaking.

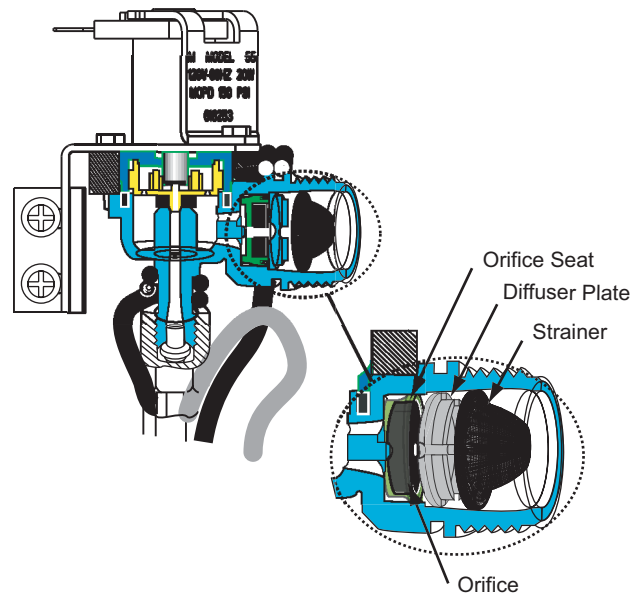

Figure 3. Arrangement of inlet side components.

Winterization Procedure

To winterize the ice maker:

1. Shut off the RV water supply to the ice maker.
2. Raise the ice maker shut-off arm until it locks in the off position.
3. Disconnect the garden hose water inlet connection from the water solenoid valve.
4. Disconnect the ice maker water supply line from the water solenoid valve. Do not unwrap the water line heater wire from the water solenoid valve outlet connection.
5. Allow the water to drain from the supply line and the ice maker water line.
6. Protect connections by bagging and taping all line and water solenoid valve connections with clean plastic bags and tape.

IMPORTANT!

On 1200LRIM refrigerators, the ice maker must be removed to allow removal of module cover to access test points. See Figure 4 for mounting screws location. Figure 5 shows test points location.

Do not perform this test if the ice ejector is trapped in the ice cubes (mold was overfilled). Allow the ice to thaw before performing the cycle test.

To perform an ice maker cycle test:

1. Shut off the water supply to the ice maker water solenoid valve.
2. Make sure the ice maker is connected to the wire harness and that the circuit is energized (120 Vac).
3. Make sure the ice maker shut-off arm is in the down (ON) position.
4. Measure voltage across test points L and N. 120 Vac should be available to the ice maker.

IMPORTANT!

Shorting test points T and H will start the cycle. Remove the jumper wire from test points T and H when a click sound is heard or immediately after a period of 15 seconds.

5. With an insulated jumper wire (14 AWG recommended. Strip 1/2 inch of insulation from each end), short terminals T and H. See Figure 5. The following events should take place during the cycle:
 - The mold heater starts to heat the mold.
 - The ice maker ejector its cycle.
 - About 15 seconds into the cycle, the heater thermostat should produce a “click” sound . **Remove the jumper wire at this time. Not removing the jumper wire will cause damage to the heater and/or overheat the mold, which will ruin the ice maker.**
 - Halfway through the cycle, the water solenoid valve is energized.
6. Time the length of time the water to determine the amount of time it remains energized (it should not exceed 7.5 seconds).
7. If the water solenoid valve does not remain energized between 3.5 and 7.5 seconds:
 - Allow the cycle to come to an end.

—Adjust the fill time duration using the water fill adjustment screw. Turn the screw clockwise to decrease the fill time; turn counterclockwise to increase the fill time.

Each 1/4 turn varies the fill by 0.34 fl.oz. (10 mL). The small hole in the water fill screw adjustment indicator should be centered in the module casing hole (see Figure 5).

—Cycle test the ice maker. Time the water solenoid valve again to determine the amount of time it remains energized. **The valve should remain energized between 3.5 to 7.5 seconds.**

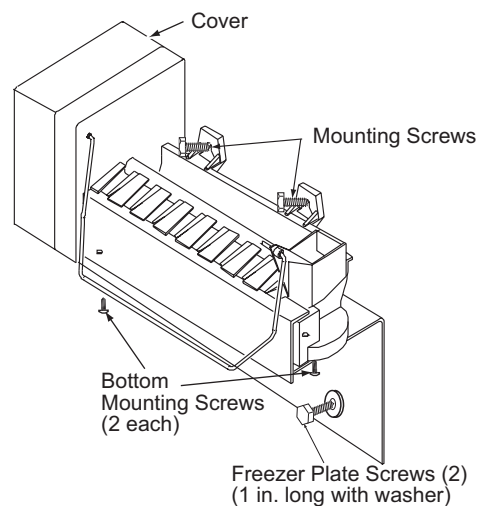

Figure 4. Mounting screws location.

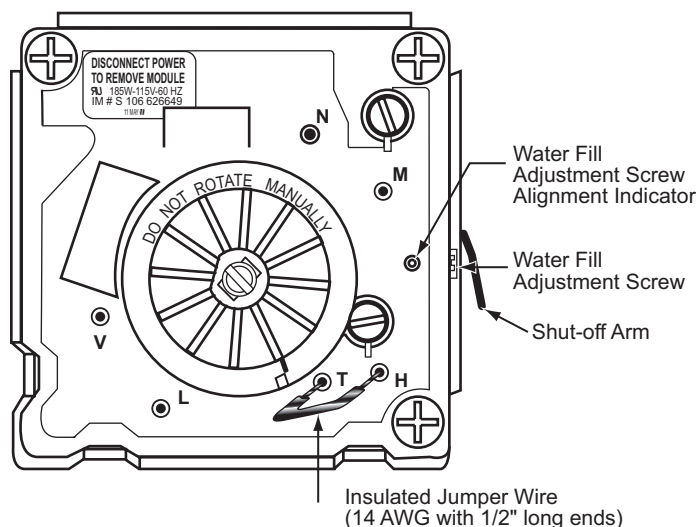

Figure 5. Test points.