

TO OPEN

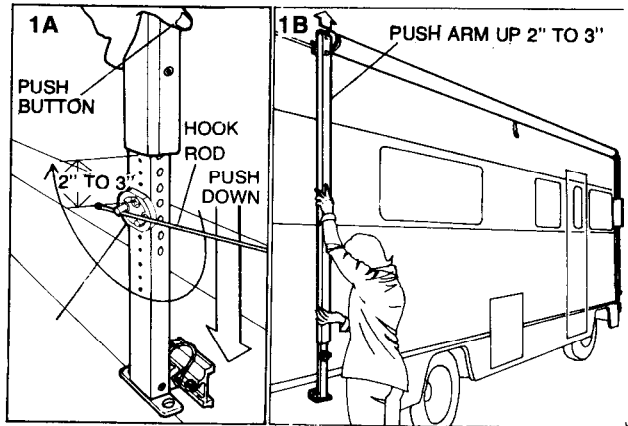

1. Insert the Hook Rod between the two Lugs of the Lift Cam as shown in Fig. 1A. Depress the Push Button with one hand and rotate the Lift Cam by pushing down on the Hook Rod with the other hand. When the Lift Cam is turned 180, release the Push Button and let the Button catch a punched hole in the side of the Adjustable Arm. The Support Arm is now unlocked. Repeat this step on the other side. If desired, the Support Arm may be unlocked without using the Lift Cam (Fig. 1B)

NOTE: Lubricate the Push Button when it becomes sticky.

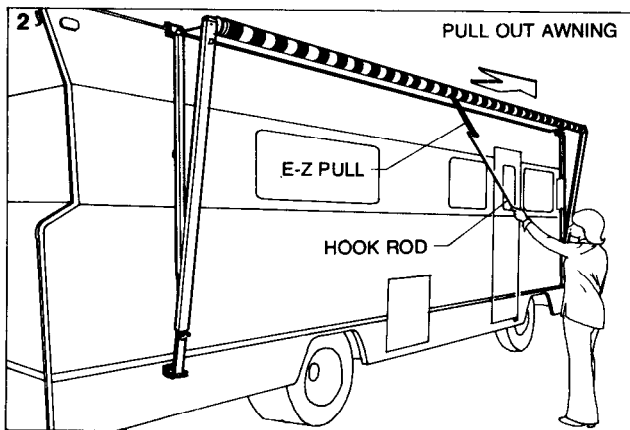

2. Pull down on the E-Z Pull and extend Awning Fabric all the way out.

NOTE: If the E-Z Pull cannot be reached, use the Hook Rod provided.

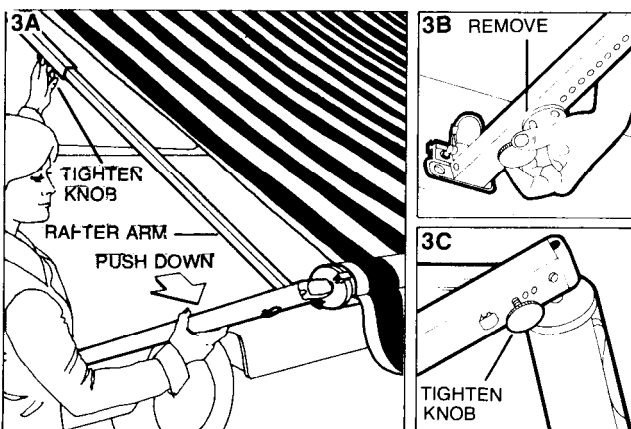

3. Keeping the Awning from rolling back, move to a side and slide the Rafter Arm up the Support Arm until it snaps into place at the top of the Support Arm.

Push Support Arm down and tighten the Knob on Rafter Arm to hold Fabric stretched. (Fig. 3A)

For the Airstream, Argosy, Silver Streak and the Park Models only, remove the Knob found at the bottom of the Support Arm (Fig. 3B) and secure it into the hole at the top of the Support Arm. (Fig. 3C) Repeat Step on the other side.

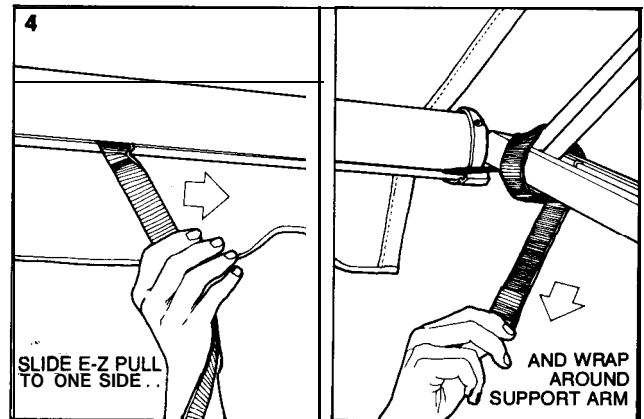

4. Put E-Z Pull out of way by sliding it over to a side and wrapping it around the Main Support Arm or the Roller Tube.

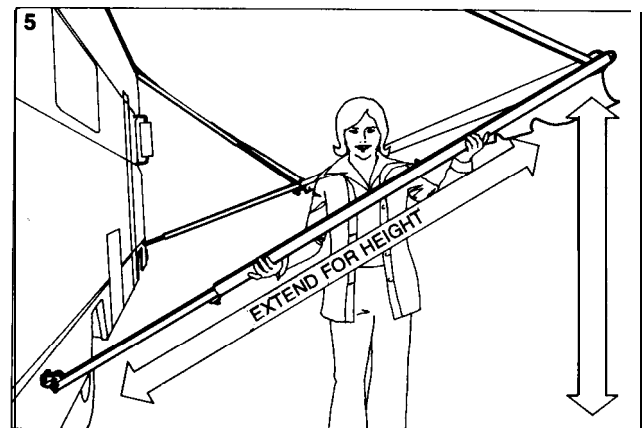

5. To raise Awning, grasp Main Support Arm, depress Side Button, and slide Arm up. When desired height is reached, release Side Button and allow it to snap into a punched hole. Extend the other Support Arm to the same height.

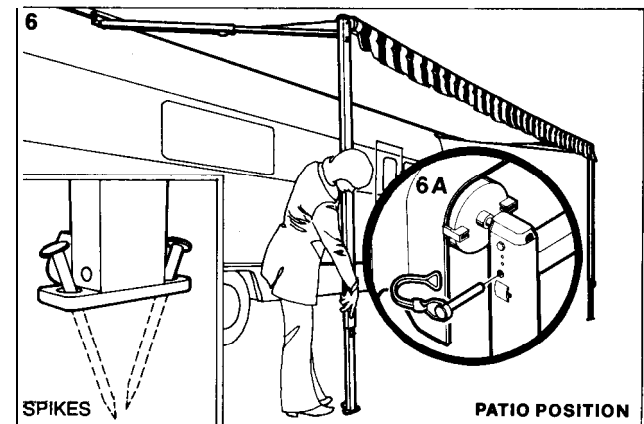

6. For extended stays and where ground conditions permit, the Patio Position allows easier access and more usable space.

Pull out the Safety Spring Pin and detach Support Arm from the Bottom Mounting Bracket. Set the Arm down on the ground vertically and adjust height. Pound in the spikes provided.

Insert lower mounting bracket Spring-Pin into hole near top of support arm to secure support and rafter together. (Fig. 6A.)

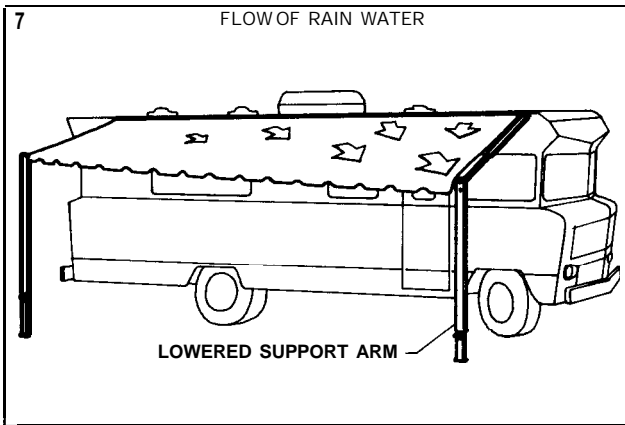

7. The Automatic Water Release must be set during rain to prevent damage from water build-up. To set it, simply lower one of the Support Arms, enough to create a down slope towards that side.

NOTE: Whenever a heavy or prolonged rain is anticipated, it is best to roll away the Awning.

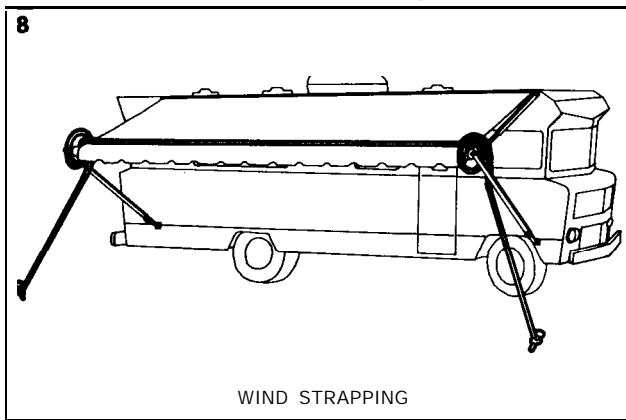

8. The Wind Strapping is for prolonged stays when it may be more practical to keep Awning set up semi-permanently. To insure against unexpected gusty winds, wrap the Strapping around Roller Tube and stake down each end as illustrated. **NOTE: Strapping is not included with Awning.**

TO CLOSE

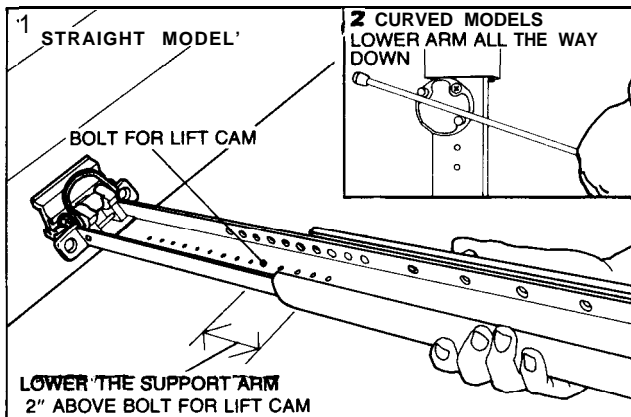

1. From Patio Position: Pull out the Stakes and attach both Support Arms back to the Bottom Mounting Brackets. Proceed to Step 2.

2. From Vehicle Mounted Position: Lower the Main Support Arm until the end of it is about 2 inches above the Bolt for the Lift Cam. See Fig. 1.

NOTE: If your Support Arms are Curved, as for the Airstream, Lower the Support Arm all the way Down to the Lift Cam. See Fig. 2. Repeat this Step for the other Support Arm.

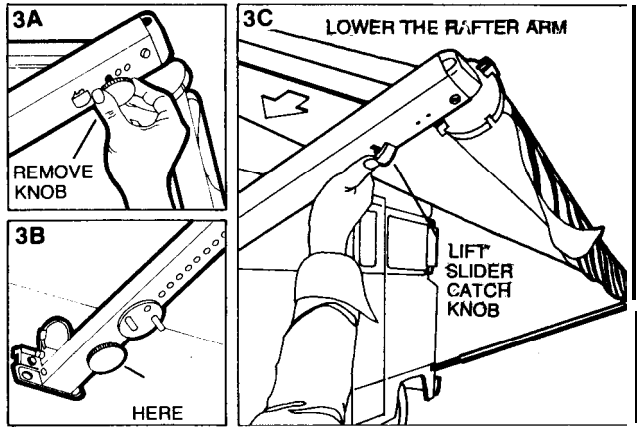

3. Return E-Z Pull to the center of the Awning. For the Airstream, Argosy, Silver Streak and the Park Models **only**, remove the knob at the top of the Support Arm and store it back into the hole at the bottom. (Fig. 3A 3B) Untighten the Knob on the Rafter Arm, and lift up Slider Catch Knob to release Rafter Arm. Slide down Rafter Arm all the way down to the bottom of Support Arm. Do not retighten the Knob. (See Fig. 3C)

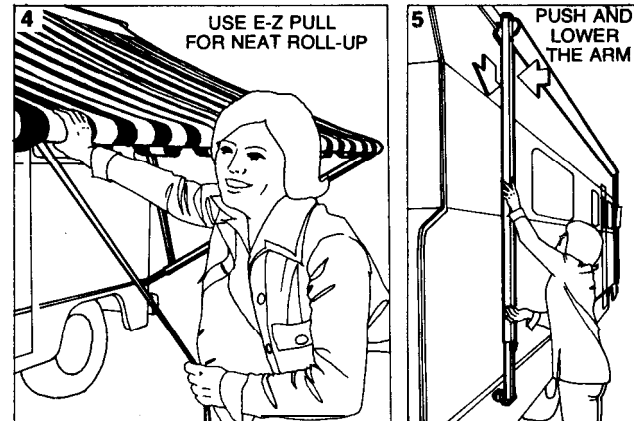

4. Let the Awning roll back all the way, using E-Z Pull for control of speed and even roll-up.

Return the E-Z Pull diagonally to avoid bulge in the middle of rolled up awning.

5. While keeping the upper part of the Support Arm pushed towards the vehicle side, press the Push Button in and lower the Arm down to the Lift Cam. Release Push Button and let it catch a punched hole.

NOTE: If you lowered the Support Arm all the way down in TO CLOSE, Step 2, you Must Raise the Arm Up to about 2\"/>

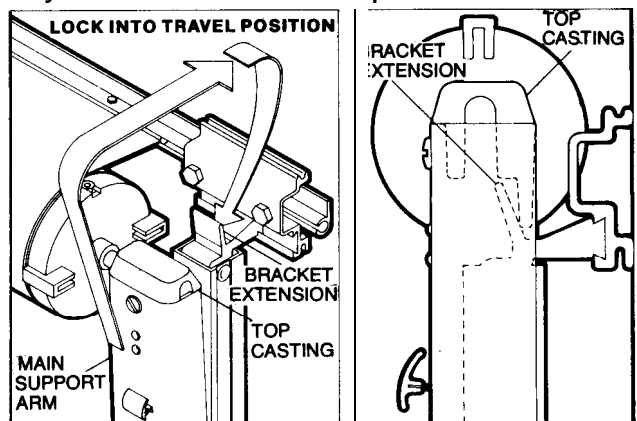

IMPORTANT: Be sure that the Top Casting at the top of the Main Support Arm is hooked over the Bracket Extension. This is the Travel Position.

When both Support Arms are secured against the vehicle, your Travel-Awn 5000 is ready for travel.