



**A&E Systems®**  
by Dometic

# **AE HORIZON**

**SERVICE OFFICE**  
THE DOMETIC CORP.  
509 S. Poplar Street  
LaGrange, IN 46761

## **INSTALLATION & OPERATING INSTRUCTIONS**

# **A&E Horizon Awning**

# INSTALLATION AND OPERATING INSTRUCTIONS

## APPLICATION

The Horizon Case Awning is designed for use on vehicles that can not accept a full sized awning. It is especially well suited for vehicles with an overcab extension where there is not sufficient surface for a bottom mounting bracket.

### **IMPORTANT !**

**READ ALL OR THE FOLLOWING STEPS BEFORE BEGINNING INSTALLATION.**

The Dometic Corporation reserves the right to modify appearances and specifications without notice.

## INSTALLATION/MOUNTING INSTRUCTIONS

**This awning must be installed by a qualified person.**

### POSITION OF THE AWNING

1. Before beginning installation of the case, be sure the door will open when the awning is completely extended. Allow for a natural downward slant of the awning.
2. Check for a solid backing or under-structure where screws and adapters are to be used.
3. For installations with mounting brackets, be sure that all mounting brackets are secured in a very solid manner.
4. Before drilling, be sure that there are no obstacles inside the wall (cables, wires, gas pipes, etc.).
5. Having evaluated the construction of the vehicle, pick the mounting style which best fits the application. (FIGS. 1 & 2).
6. Minimum clearance from bottom of case to door is 3.00 inches.

### WITH MOUNTING BRACKETS

FIG. 1

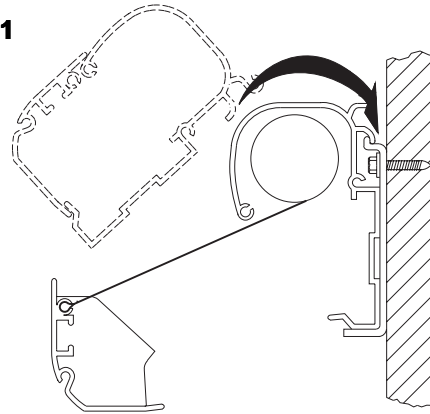

### WITH OPTIONAL AWNING RAIL (NOT PROVIDED)

FIG. 2

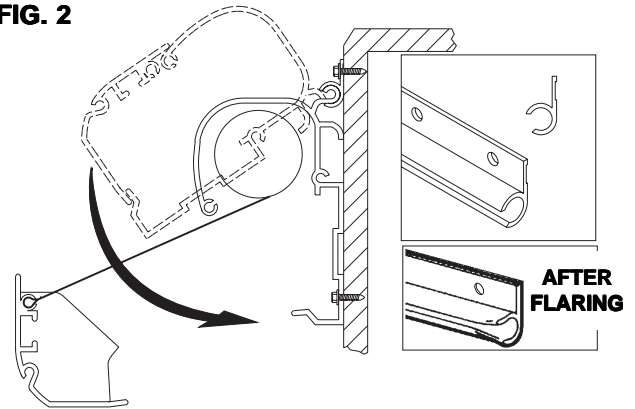

## INSTALLATION USING STANDARD BRACKETS

1. Determine locations of mounting brackets on side of vehicle. The center mounting bracket should be of equal distance between front and rear brackets. (FIG. 3, Page 3)
2. Mark the top bracket position and pre-drill holes using a 3/16" drill bit (use 7/32" drill bit if drilling through steel). Install top brackets with #14 x 1-1/2" screws provided.
3. If mounting area sub-structure is not solid, we recommend using nuts and bolts and backing plate inside the vehicle. (FIG. 4, Page 3)
4. Set the awning on mounting brackets. Using hole in bottom mounting leg of mounting bracket, drill a 3/16" dia. hole into bottom of awning case. Install a pan head machine screw and nut as shown in FIG. 5, Page 3. Repeat for other brackets.

FIG. 3

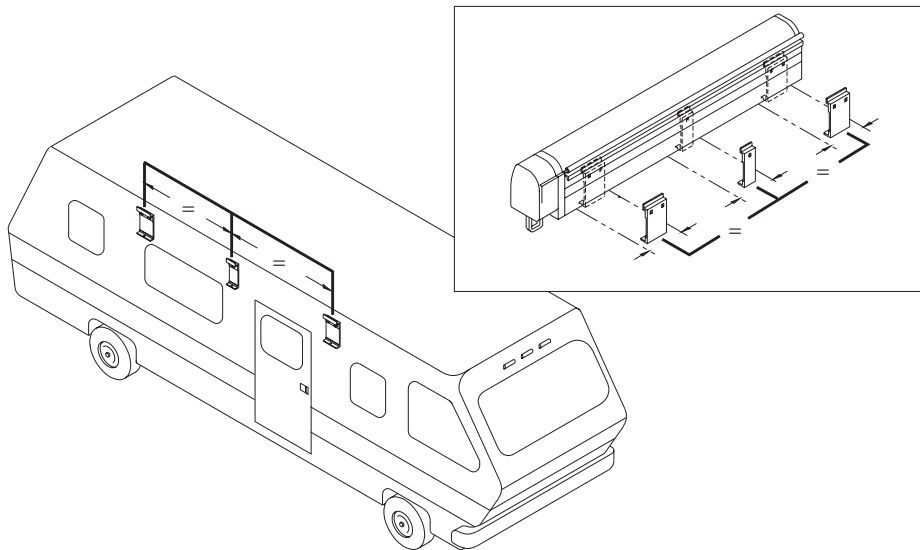

FIG. 4

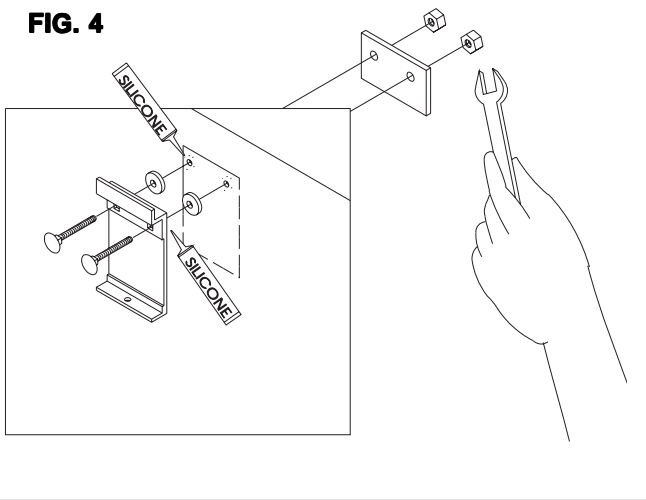
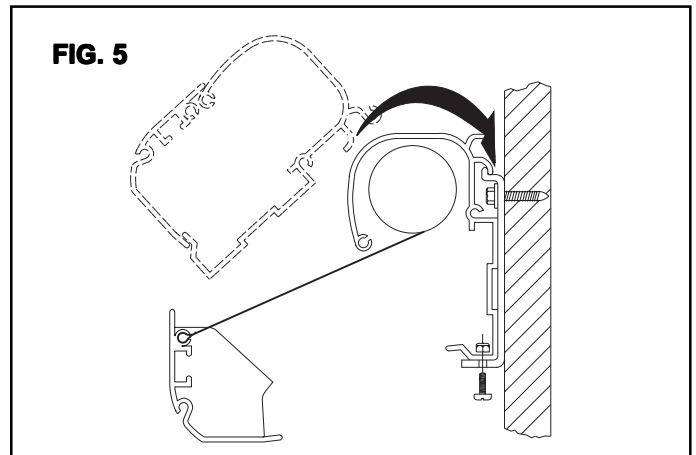

FIG. 5



**OPTIONAL AWNING RAIL INSTALLATION  
(See FIG. 2)**

1. Because the cantilevered force is concentrated on the upper-side of the case, be sure that the awning rail is several inches longer than the awning case at both ends.
2. To aid in installation, flare end of awning rail BEFORE attempting to slide awning into rail (FIG. 2, Page 2). NOTE: On shorter awning with straight awning rail, awning can be tipped into rail (FIG. 6)
3. When using the awning rail, it is necessary to fasten the awning securely to the sidewall of the vehicle. Using a 1/4" drill bit, drill a hole at the center of the awning (see FIG. 6). **DO NOT drill into the sidewall yet.**
4. Within 1 to 2 feet of the end of the awning, drill another hole using a 1/4" drill bit. Repeat for the other end.

5. Using a 3/16" drill bit (7/32" bit if drilling into steel) and using the 1/4" holes drilled in Steps 2 and 3 above as guides, drill into the sidewall of vehicle. Install #14x1-1/2" screws and tighten.

FIG. 6

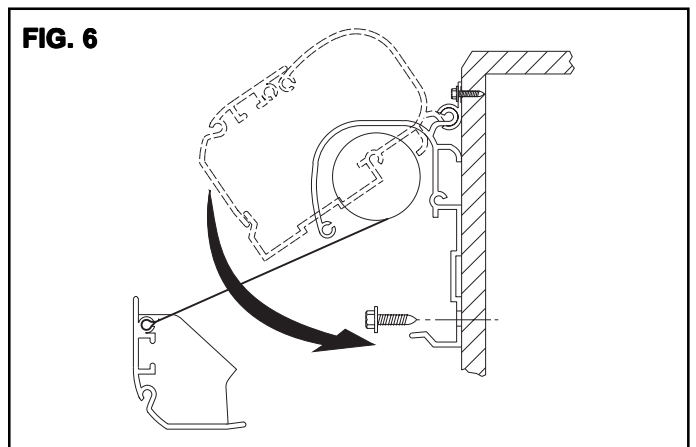

## INSTALLATION OF BOTTOM MOUNTING BRACKETS

**IMPORTANT: Always mount into solid under-structure.**

1. Location of bottom mounting brackets must be set so that upright legs are vertical when retracted from case. (FIG. 7) To determine the location of bottom mounting bracket, fully extend awning. Remove arms from lead rail and place against side of vehicle. Loosen black adjustment knob and extend arm until lead rail is at desired height. Mark location on side of vehicle to maintain this height (FIG. 8)

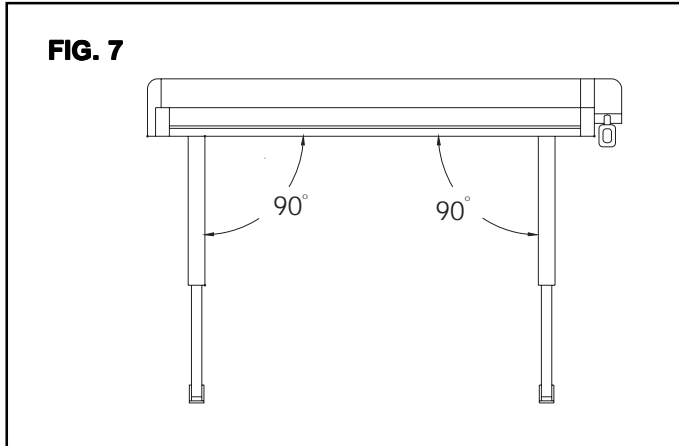

2. Using the holes in the brackets as a guide, mark and drill using a 5/32" drill bit. Secure each bracket to vehicle using pan head sheet metal screws provided.

If mounting area sub-structure is not solid, use backup plate inside the vehicle. (FIG. 8)

## OTHER INSTALLATION NOTES

1. To prevent water leakage, always use silicone sealant where each fastener enters the sidewall or roof of the vehicle.
2. To prevent damage to the fabric during drilling, unroll the fabric completely and adjust the legs to their highest position while keeping the fabric horizontal.
3. **DO NOT** over-tighten fasteners. This will cause them to "strip out" and severely weaken their holding ability.

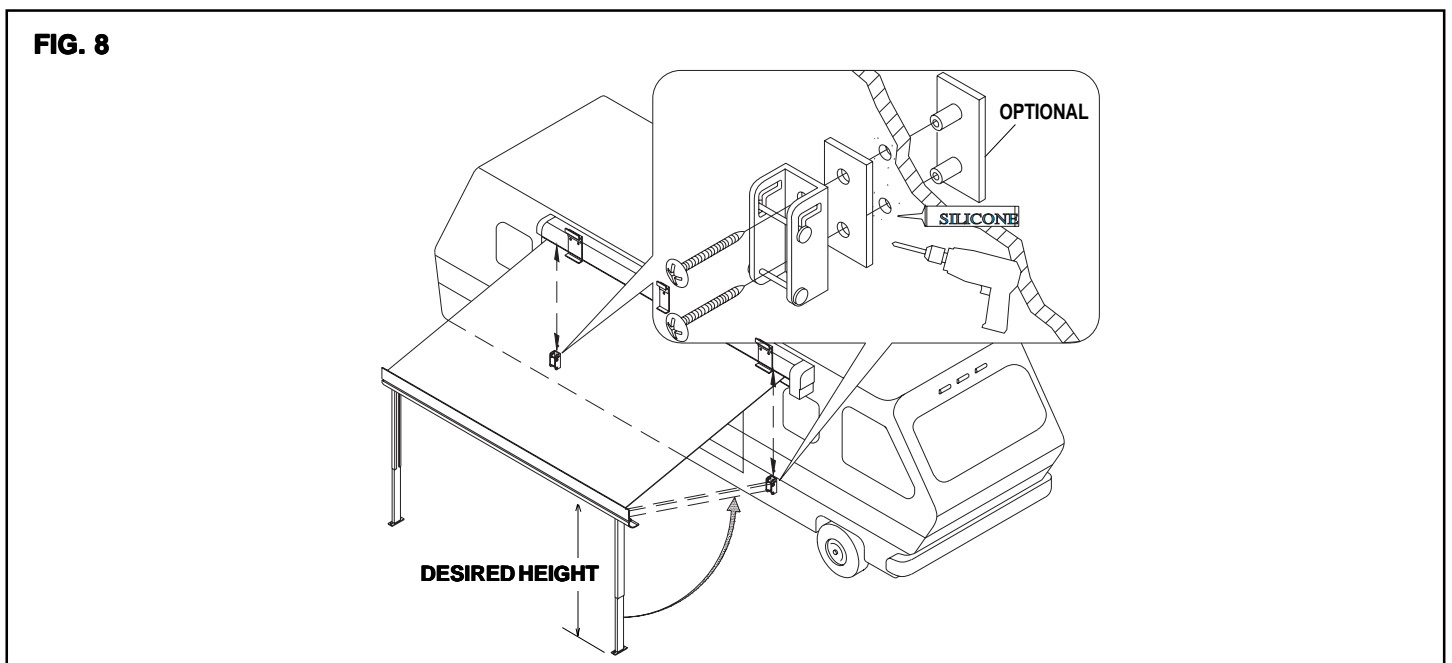

# OPERATING INSTRUCTIONS

To assist in the awning setup, locate the legs to the ground after approximately 3-feet of the canopy is extended. This reduces any strain on the walls/brackets of the vehicle. (FIG. 9)

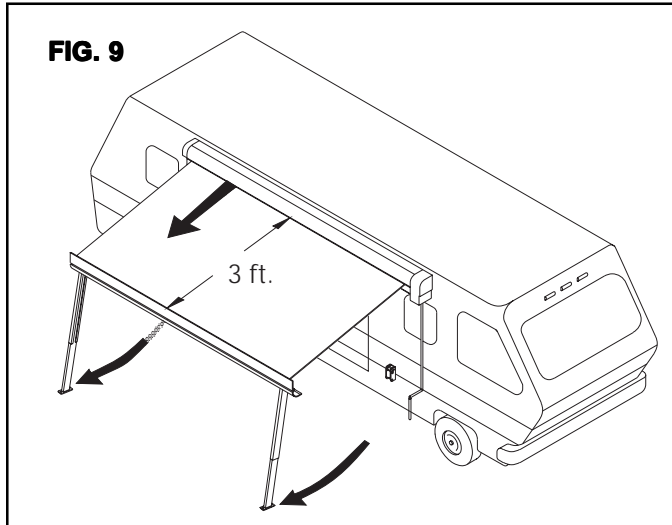

## TO OPEN

1. Place the hook of the crank into the eye of the gear and completely unroll the awning.

The awning will be fully extended when fabric starts to sag. After this occurs, roll awning back 1/4 turn to reach maximum tension.

2. Loosen the lock knobs on the support arms and slide each arm away from the center of the lead rail. Swing each arm downward to the ground. (FIG. 10)

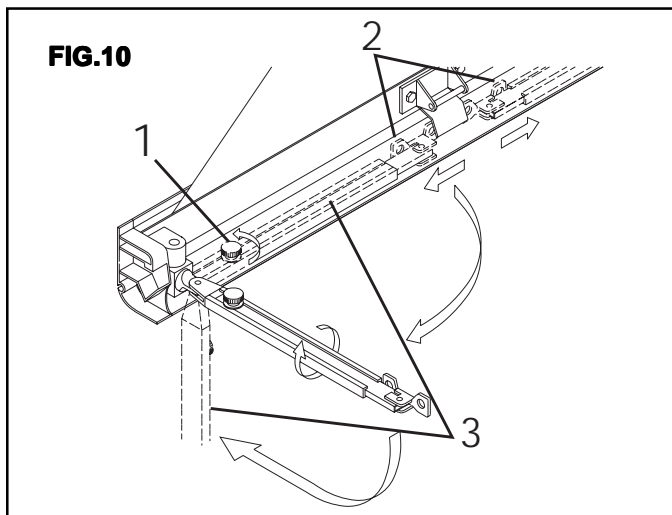

3. For **car port position**, stake the support arms to the ground with stakes provided. (FIG. 11)

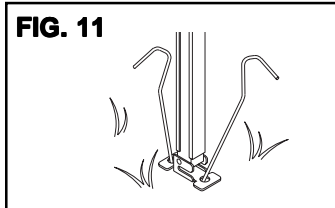

For patio position, engage the support arm foot into the bottom mounting bracket. (FIG. 12)

4. Roll up the awning a little - until the fabric is taut.

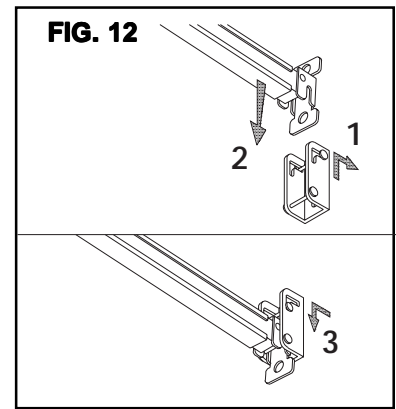

## TO CLOSE

1. Loosen the black knob and slide the support arms completely together.
2. Place the hook of the crank into the eye of the gear and roll awning up, to within 3-feet of being closed.
3. Rotate the support arms upward and place them under the closing plate of the lead rail. Tighten the knobs.
4. Finish rolling up awning. Case is self-locking.

## ! CAUTION

**Fabric must roll around roller tube from bottom of roller tube. Make sure the awning is correctly closed by observing the red indicators at either end of the awning.**

## OTHER OPERATION NOTES

1. To resist unexpected gusts of wind, it is always best to set awning support arms into the pivot position. If car port position is to be used, be sure that the awning feet are properly staked into the ground. For further protection we recommend the ends of the awning lead rail be tied with straps (not provided) and staked to the ground.
2. **If heavy wind conditions exist, retract awning and place in storage position!**
3. Light-Rain Release Setting: Lower one side of the awning so that the water can drain off. (FIG. 13, Page 6)
4. 12 ft. – 16 ft. awnings come with a center tension rafter. Install as shown in FIG. 14, Page 6.
5. The storage bracket is supplied for crank assembly. (FIG. 15, Page 6).
6. Crank assembly can be shortened as shown in FIG. 16.

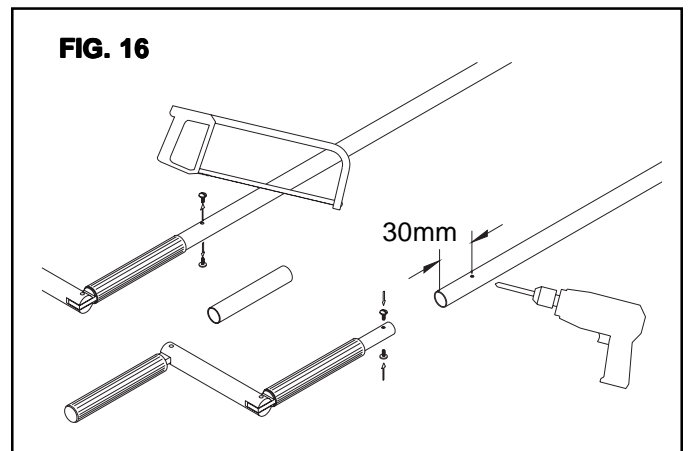
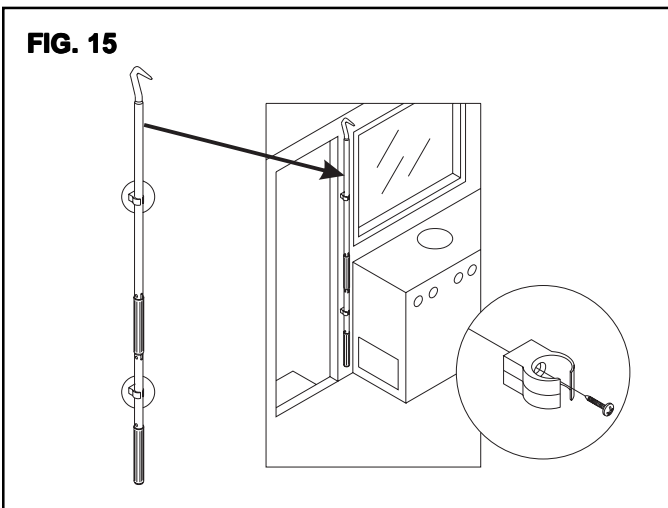
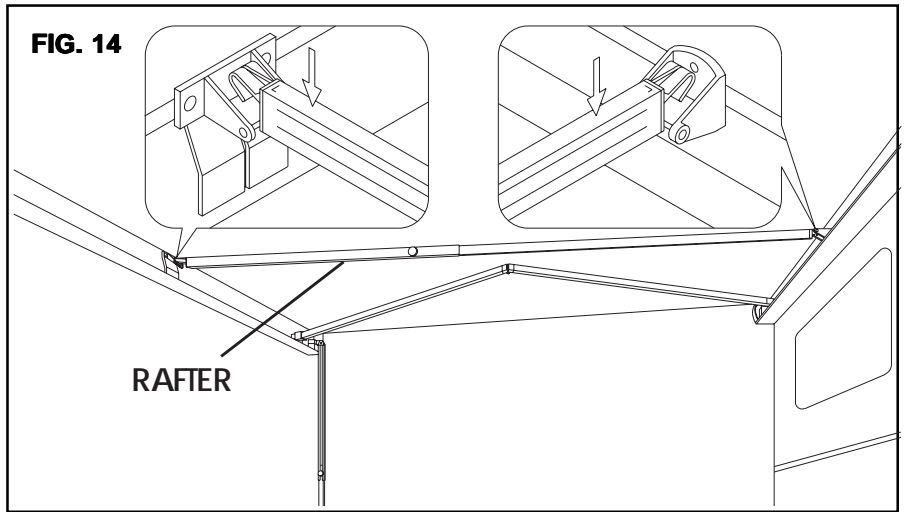
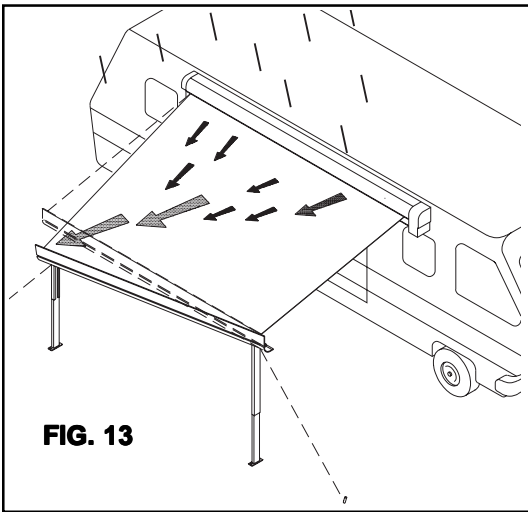

**WE REMIND YOU THAT THE AWNING IS TO SHELTER YOU FROM THE SUN, NOT FROM RAIN, WIND OR SNOW.**

## OWNER MAINTENANCE ITEMS

1. Lubricate the rafter arms and support arms using paraffin wax or silicone spray. Also lube the threads on the knobs.
2. Periodically clean the awning fabric with A&E "Canopy Clean", Dometic Part No. 3104669.001. Allow to dry before rolling awning back up.
3. Mildew cannot form on the fabric, but rather will form on dirt or dust on the fabric. The key is to keep the fabric clean.
4. To remove grease spots from vinyl fabrics, use only a soap and water solution. Avoid use of caustic household cleaners, mildew removers or hard bristle brushes.
5. Occasionally the awning may develop a pinhole, actually a spot of paint flakes off from the top layer of vinyl. This may be quickly remedied with a very small dab of VLP (Vinyl Liquid Patch) on the tip of a Q-tip®. By gently rolling the Q-tip® around the pinhole, the VLP will melt the paint (in the stripe) and that will quickly fill in the pinhole with a perfect match. Be sure to wait until the VLP (Part No. 143498) sets before rolling up the awning.
6. Always make sure the awning is extended high enough before opening entry door.
7. Lower one end of awning for proper water run-off and to avoid water pooling.