

# Duo-THERM<sup>®</sup>

by Dometic

RECORD THIS UNIT INFORMATION FOR FUTURE REFERENCE:

Model Number \_\_\_\_\_  
Serial Number \_\_\_\_\_  
Date Purchased \_\_\_\_\_

## 579 Series BRISK AIR 590 Series QUICK COOL 595 Series QUICK COOL

### Roof Top Air Conditioner

### USED WITH Part No. 3107206 Air Distribution Box Kit

#### PRE-WIRED FOR OPTIONAL HEAT PACKAGE

**USA**  
SERVICE OFFICE  
The Dometic Corp.  
509 So. Poplar St.  
LaGrange, IN 46761  
(219) 463-4858

**CANADA**  
Dometic Dist.  
866 Langs Dr.  
Cambridge, Ontario  
CANADA N3H 2N7  
(519) 653-4390

For Service Center  
Assistance Call:  
800-544-4881

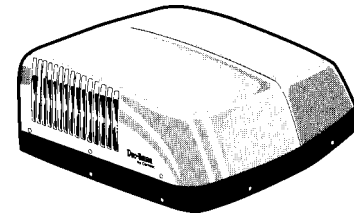

#### **! WARNING**

Improper installation, adjustment, alteration, service or maintenance can cause injury or property damage. Refer to this manual. For assistance or additional information consult a qualified installer or service agency.

#### **! AVERTISSEMENT**

Une mauvaise installation, de mauvais réglages, modifications ou opérations d'entretien peuvent endommager les biens ou même blesser. Se reporter à la notice. Pour obtenir de l'aide ou des renseignements complémentaires, consulter un installateur qualifié ou une agence de service après-vente.

## INSTALLATION & OPERATING INSTRUCTIONS

#### REVISION

Form No. 3107195.012 3/98  
(Replaces 3107195.004)  
©1998 The Dometic Corporation  
LaGrange, IN 46761

### MODELS

57908.521	59016.521
57912.621	59016.526
57912.622	59016.621
57915.421/.426	59016.626
57915.422	59516.501
57915.521/.526	59516.506
57915.522	59516.601
57915.621/.626	59516.606
57915.622	

# 1. SPECIFICATIONS

		57912	57915	57915	57915	59016.521	59516.501
<b>MODEL NUMBER</b>	<b>57908.521</b>	.621 / .622	.421 / .426	.521 / .526	.621 / .622	<b>59016.526</b> <b>59016.621</b> <b>59016.626</b>	<b>59516.506</b> <b>59516.601</b> <b>59516.606</b>
Nominal Capacity (BTU/HR)	7,100	11,000	13,500	13,500	13,500	15,000	15,000
Electrical Rating	115 VAC, 60 Hz., 1 PH.						
Compr. Rated Load Amps	6.6	8.5	11.5	12.1	11.0	12.9	12.9
Fan Motor Rated Load Amps	2.5	2.5	2.5	2.5	2.5	2.5	2.5
Compr. Locked Rotor Amps	34.0	48.3	50.0	59.0	54.4	71.0	71.0
Fan Motor Locked Rotor Amps	5.8	5.8	5.8	5.8	5.8	6.0	6.0
Heater Amps/Watts @ 120VAC	12.7 Amps; 1530 Watts; at 120 Volts AC						
Refrigerant (R22) oz.	17.0	16.0 / 18.5	13.5 / 14.5	16.0 / 16.5	16.0 / 16.5	26.5	31.0
Minimum Wire Size *	12 AWG Copper up to 24 ft.						
Circuit Protection	20 Amp Time Delay Fuse or HACR Circuit Breaker						
Installed Weight (Pounds)	75	93	100	95	95	110	111
Minimum Generator Size **	1 UNIT	2.5 KW		3.5 KW			
	2 UNITS	4.0 KW		5.0 KW			

\* For lengths over 24 ft., consult the National Electrical Code.

\*\* The Dometic Corp. gives **general** guidelines for generator requirements. These guidelines come from experiences people have had in actual applications. When sizing the generator, the **total** power usage of your recreational vehicle must be considered. Also keep in mind generators lose power at high altitudes and from lack of maintenance.

## 2. PRECAUTIONS



**IMPROPER INSTALLATION MAY DAMAGE EQUIPMENT, COULD ENDANGER LIFE, CAUSE SERIOUS INJURY AND/OR PROPERTY DAMAGE.**

- Read installation and operating instructions carefully before attempting to start your air conditioner.
- The Dometic Corporation will not be liable for any damages or injury incurred due to failure in following these instructions.
- Installation **must** comply with the National Electrical Code and any State or Local Codes or regulations.
- DO NOT** add any devices or accessories to this air conditioner except those specifically authorized by Dometic.
- This equipment must be serviced by qualified personnel and some states require these people to be licensed.

## 3. OPERATING INSTRUCTIONS

### A. CONTROLS:

- The Selector Switch has eight positions including "OFF". This controls fan speed, heating mode, and cooling modes.
- The Thermostat controls the temperature range from 65°F on the coldest side to 90°F on the warmest side. In the cooling mode, the compressor ON/OFF controlled by the thermostat setting.

### B. COOLING OPERATION:

- Set the thermostat at the desired temperature level.
- Select the fan speed that best satisfies your needs:
  - HIGH COOL:** Selected when maximum cooling and dehumidification required.
  - MED. COOL:** Selected when normal or average cooling required.

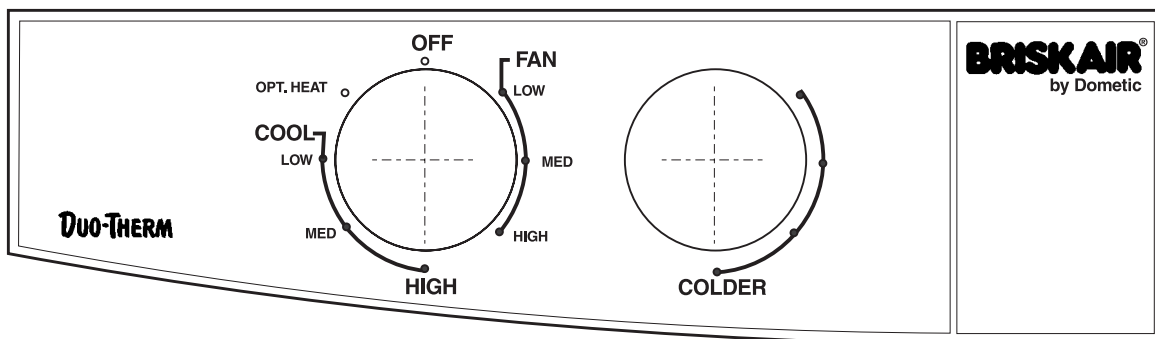

- c. **LOW COOL:** Selected when room at desired comfort level and needs to be maintained. Normally this speed used for night time operation.

**NOTE:** The blower runs continuously to circulate air and maintain an even temperature. The compressor will come on as cooling is required to maintain the selected temperature level.

**! WARNING**

**AFTER SHUTTING THE AIR CONDITIONER DOWN WITH EITHER SELECTOR SWITCH OR THERMOSTAT, WAIT AT LEAST TWO (2) MINUTES BEFORE RESTARTING. THIS ALLOWS THE REFRIGERANT PRESSURE TO EQUALIZE AND COMPRESSOR TO RESTART EASILY.**

**C. FAN OPERATION:**

This will circulate the air in your RV without cooling or heating. There are three positions: HIGH FAN, MED. FAN or LOW FAN to select from, depending upon personal choice.

**D. HEATING OPERATION:**

(With Optional Heat Kit Installed)

**NOTE:** This electric heater will not replace a furnace for heating your RV in cold weather. The intent is to remove the chill on cool days or mornings.

1. Turn the selector switch to "OPT. HEAT".
2. The Heater will come on and begin heating.
3. When desired temperature level in RV is reached, move the selector switch to off position or fan position. (NOTE: Thermostat does not control heater ON/OFF cycle.)

- E. **"OFF" POSITION:** This is to turn Unit off.

## 4. MAINTENANCE

**A. AIR FILTER:**

Periodically remove the return air filter located above the removable panel in the air box. Wash the filter with soap and warm water, let dry and the reinstall.

**NOTE:** Never run the air conditioner without return air filter in place. This may plug the unit evaporator coil with dirt and may substantially affect the performance of the unit.

**B. AIR BOX HOUSING:**

Clean air box housing and control panel with a soft cloth dampened with a mild detergent. Never use furniture polish or scouring powders.

**C. FAN MOTOR:**

Factory lubricated and requires no service under normal use.

**D. FROST FORMATION ON COOLING COIL:**

Under certain conditions, frost may form on the evaporator coil. If this should occur, inspect the filter and clean if dirty. Make sure air louvers are not obstructed.

Air conditioners have a greater tendency to frost when the outside temperature is relatively low. This may be prevented by adjusting the thermostat control knob to a warmer setting (counter clockwise). Should frosting continue, operate on LOW, MED. or HIGH FAN setting until the cooling coil is free of frost.

## 5. GENERAL INFORMATION

The ability of the air conditioner to maintain the desired inside temperature depends on the heat gain of the RV. Some preventative measures taken by the occupants of the RV can reduce the heat gain and improve the performance of the air conditioner. During extremely high outdoor temperatures, the heat gain of the vehicle may be reduced by:

- a. Parking the RV in a shaded area
- b. Using window shades (blinds and/or curtains)
- c. Keeping windows and doors shut or minimizing usage
- d. Avoiding the use of heat producing appliances

Starting the air conditioner early in the morning and giving it a "head start" on the expected high outdoor ambient will greatly improve its ability to maintain the desired indoor temperature.

### NOTE

The manufacturer of this air conditioner will not be responsible for damage caused by condensed moisture on ceilings or other surfaces. Air contains moisture and this moisture tends to condense on cold surfaces. When air enters the RV, condensed moisture may appear on the ceiling, windows, metal parts, etc. The air conditioner removes this moisture from the air during normal operation. Keeping doors and windows closed when this air conditioner is in operation will minimize condensed moisture on cold surfaces.

## 6. SERVICE - Unit Does Not Operate

If your unit fails to operate or operated improperly, check the following before calling your service center.

- A. If RV connected to motor generator, check to be sure motor generator is running and producing power.
- B. If RV connected to power supply by a land line, check to be sure line is sized properly to run air conditioner load and it is plugged into power supply.
- C. Check your fuse or circuit breaker to see if it is open.
- D. After the above checks, call your local service center for further help. This unit must serviced by qualified service personnel only.

When calling for service, always give the air conditioner Model Number and Serial Number. This information can be found on unit rating plate located on the base pan near the return air opening. Return air grille must be removed from air box to view.

## 7. INSTALLATION INSTRUCTIONS

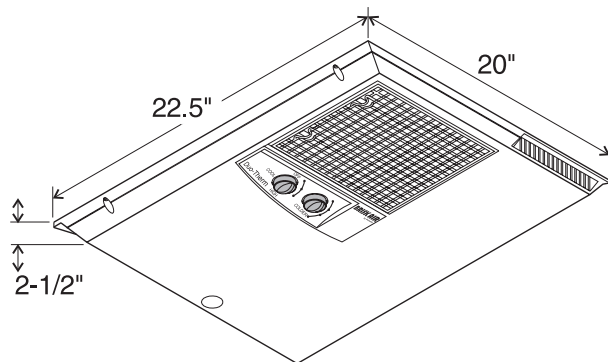
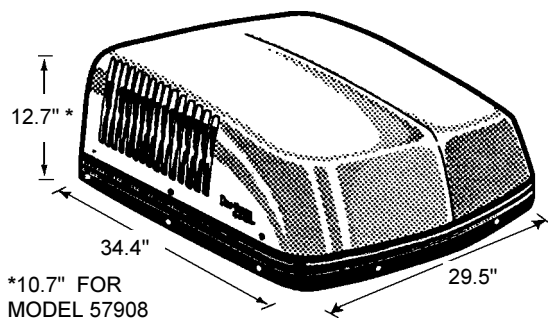

### A. PRECAUTIONS

#### **! WARNING**

**IMPROPER INSTALLATION MAY DAMAGE EQUIPMENT, COULD ENDANGER LIFE, CAUSE SERIOUS INJURY AND/OR PROPERTY DAMAGE.**

1. Read Installation and operating instructions carefully before starting your air conditioner installation.
2. The Dometic Corporation will not be liable for any damages or injury incurred due to failure in following these instructions.
3. Installation must comply with the National Electrical Code and any State or Local Codes or regulations.
4. DO NOT add any devices or accessories to this air conditioner except those specifically authorized by Dometic.
5. This equipment must be serviced by qualified personnel and some states require these people to be licensed.

### B. CHOOSING LOCATION FOR THE AIR CONDITIONER

This air conditioner is specifically designed for installation on the roof of a recreational vehicle (RV).

#### 1. NORMAL LOCATIONS:

The air conditioner is designed to fit over an existing roof vent opening. When the vent is removed, it normally creates a 14" x 14" opening.

#### 2. OTHER LOCATIONS:

When no roof vent is available or another location is desired, the following is recommended:

- a. For one unit installation: The air conditioner should be mounted slightly forward of center (front to back) and centered from side to side.
- b. For two unit installations: Install one air conditioner 1/3 and one air conditioner 2/3's from front of RV and centered from side to side.

It is preferred that this air conditioner be installed in a relatively flat and level roof section measured with the RV parked on a level surface; however, up to 15° slant to either side, or front-to-back, is acceptable.

#### 3. AFTER LOCATION SELECTION:

- a. Check for obstructions in the area where air conditioner will be installed.
- b. The roof must be designed to support 130 pounds when the RV is in motion. Normally a 200 lb. static load design will meet this requirement.
- c. Check inside the RV for air box obstructions. (i.e. door openings, room dividers, curtains, ceiling fixtures, etc.)

KEEP THIS AREA FREE OF OBSTRUCTIONS

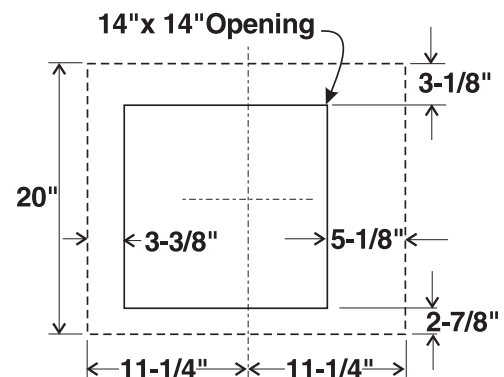
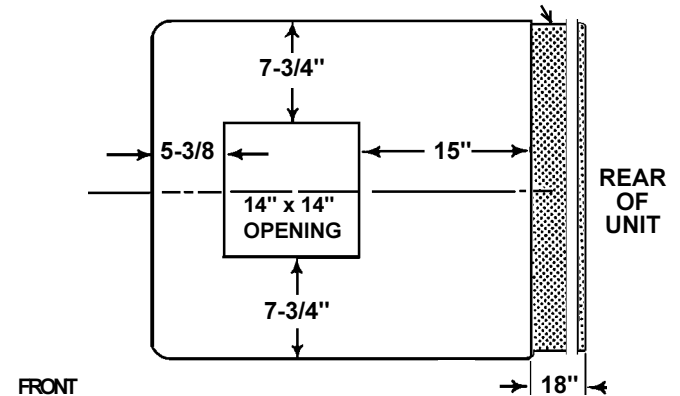

### C. ROOF PREPARATION

#### 1. ROOF VENT REMOVAL:

- a. Unscrew and remove the roof vent.
- b. Remove all caulking compound around opening.
- c. Seal all screw holes and seams where the roof gasket will be located. Use a good grade of all weather sealer.

2. **NEW OPENING:**  
(Installations Other Than Vent Openings)

**! WARNING**

**DISCONNECT ALL POWER SUPPLIES AND THE POSITIVE (+) TERMINAL FOR THE SUPPLY BATTERY. FAILURE TO FOLLOW THIS INSTRUCTION MAY CREATE A SHOCK HAZARD.**

- a. A 14" x 14" opening must be cut through the roof and ceiling of the RV. It is recommended this opening be located between roof reinforcing members.
- b. Mark a 14" x 14" square on the roof and carefully cut the opening.
- c. Using the roof opening as a guide, cut the matching hole in the ceiling.

**CAUTION: There may be electrical wiring between the roof and ceiling.**

3. **OPENING PREPARATION:**

- a. If the opening exceeds 14-1/2" x 14-1/2", it will be necessary to install spacers.
- b. If the opening is less than 14" x 14", it must be enlarged.
- c. Route a copper 12 AWG, with ground, supply line from the fuse or circuit breaker box to the roof opening.
  1. The power supply must be on a separate 20 amp Time Delay Fuse or HACR Circuit Breaker.
  2. Wiring must comply with all National, State and Local wiring codes.
  3. Make sure at least 20" of wire extend into the roof opening. This insures easy air conditioner attachment.
  4. If vent fan was removed, the existing wire may be used provided it is of proper size and correctly fused.
- d. The opening must be framed to provide adequate support and prevent air from being drawn from the roof cavity. Lumber 3/4" thick or more and long enough to bridge the opening must be used. Remember to provide an entrance hole for the power supply wire.

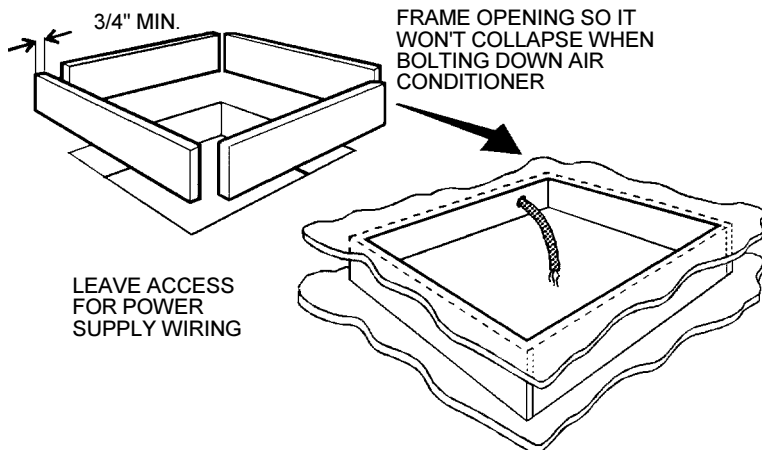

**NOTE: NEVER create a LOW SPOT on the roof where water will collect. Water standing around the air conditioner may leak into the RV interior.**

e. The 14" x 14" roof opening is part of the return air duct and must be finished in accordance with NFPA standard 501C, Standard for Recreational Vehicles, Section 2-7.

**D. PLACING THE AIR CONDITIONER ON THE ROOF**

1. Remove the Air Conditioner from the carton and discard the carton.
2. Place the air conditioner on the roof.

**CAUTION: Use care in lifting- this unit weights approximately 100 pounds.**

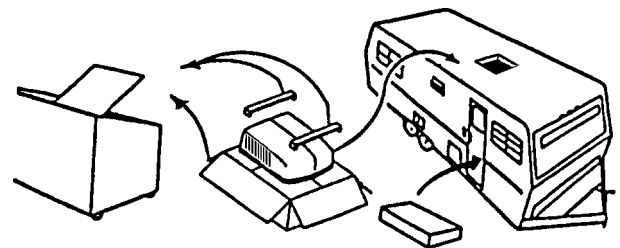

3. Lift and place the unit over the prepared opening using the gasket as a guide. The condenser coil goes toward the rear of the RV.

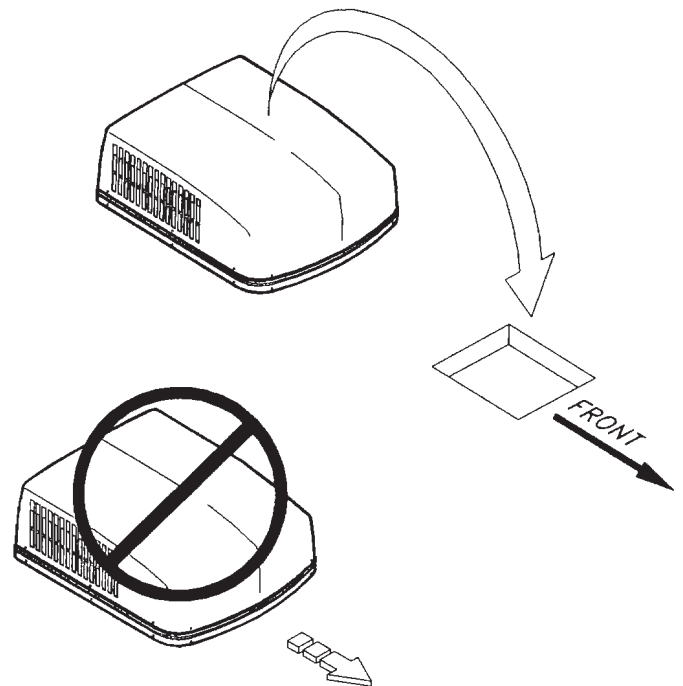

**CAUTION: DO NOT slide the unit. This may damage the neoprene gasket attached to the bottom and create a leaky installation.**

## MOUNTING PARTS

- A. (4) 1/4" — #20 x 7" bolts

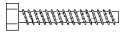

- B. (4) #8 x 5/8" long sharp point wood screws



- C. (7) #10 x 3/8" blunt point tapping screws



- D. (1) Romex connector



- E. (1) Hole Plug



## AIR CONDITIONING UNIT

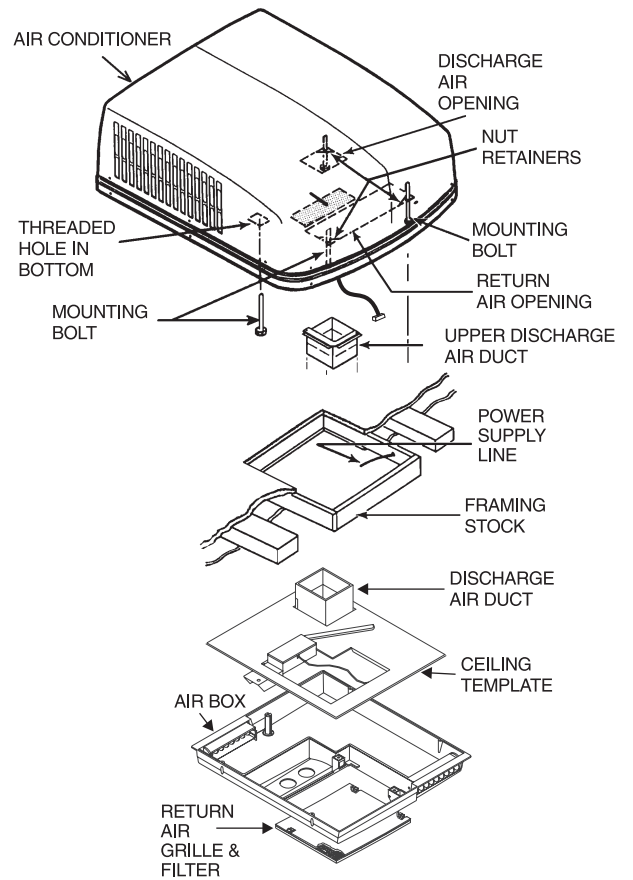

115 VA C  
60 HZ 1 P H  
USE COPPER  
CONDUCTORS  
ONLY

--- FIELD WIRING  
— FACTORY WIRING  
● LINE SPICE

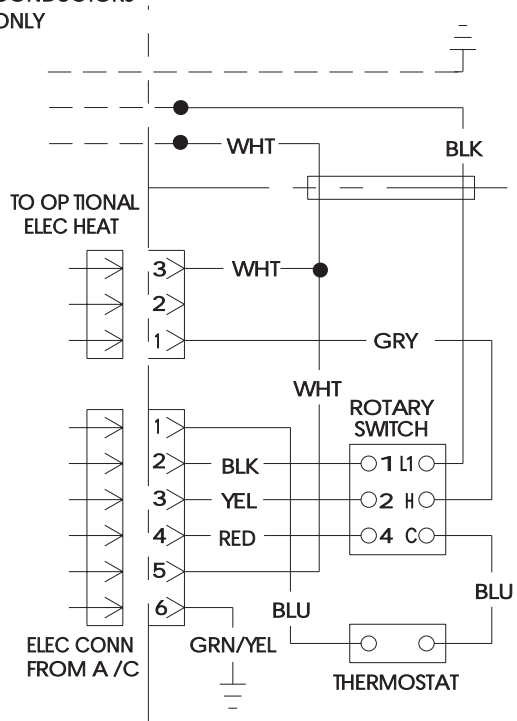

3105024.008

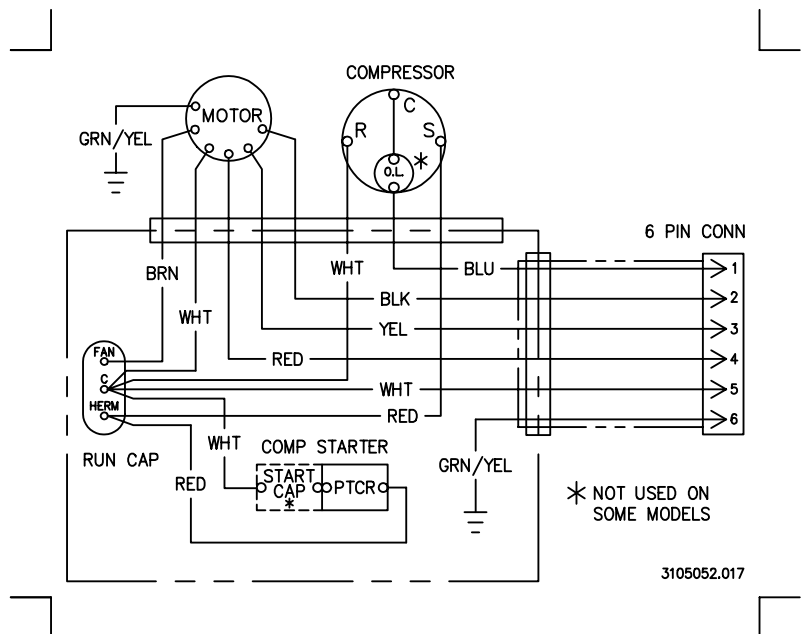

3105052.017



- Place the 3107206 Air Box Kit inside the RV. This box contains mounting hardware for the air conditioner and will be used inside the RV.

This completes the outside work. Minor adjustments can be done from the inside if required.

## E. DISCHARGE DUCT AND CEILING TEMPLATE INSTALLATION

- Remove air box and mounting hardware from carton. The upper duct is shipped inside the lower duct which is part of the ceiling template.
  - Remove upper duct from ceiling template and locate it over blower discharge.

**NOTE: Edges without flanges install toward REAR and SIDE of opening.**

- Use two (2) #10 x 3/8" screws (C) to hold duct to base pan. Holes provided in bottom of basepan for these screws to go into.

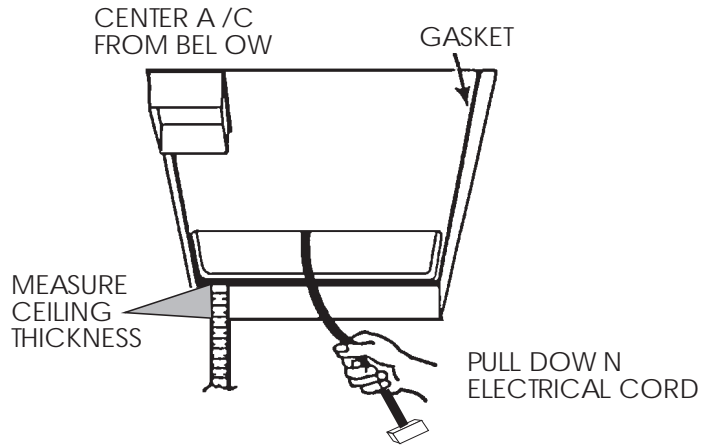
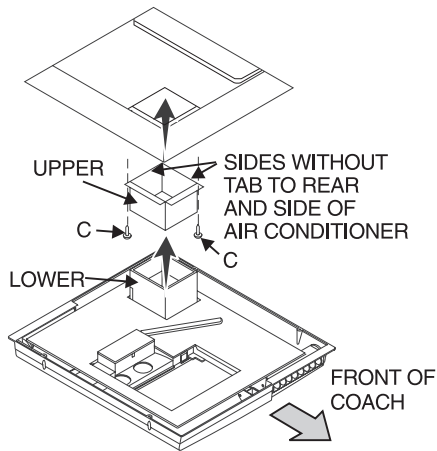

- Check for correct alignment and adjust the unit as necessary (Roof Gasket centers over 14" opening).
- Reach up into return air opening of the air conditioner and pull the unit electrical cord down for later connection.
- Measure the ceiling to roof thickness:
  - If distance is 1"-2", remove perforated tabs from both upper and lower ducts.
  - If distance is 2"-3", remove perforated tabs from bottom duct only.
  - If distance is 3"-4", install ducts as received.
  - If distance is 4"-6", use optional duct adaptor, Part No. 313606.000 and Bolt Kit, Part No. 3100895.006.
- Install ceiling template by sliding lower duct over upper duct.
- Start each mounting bolt by hand before tightening any of them. The four (4) threaded inserts in the base pan can be seen to aid in starting the bolts.

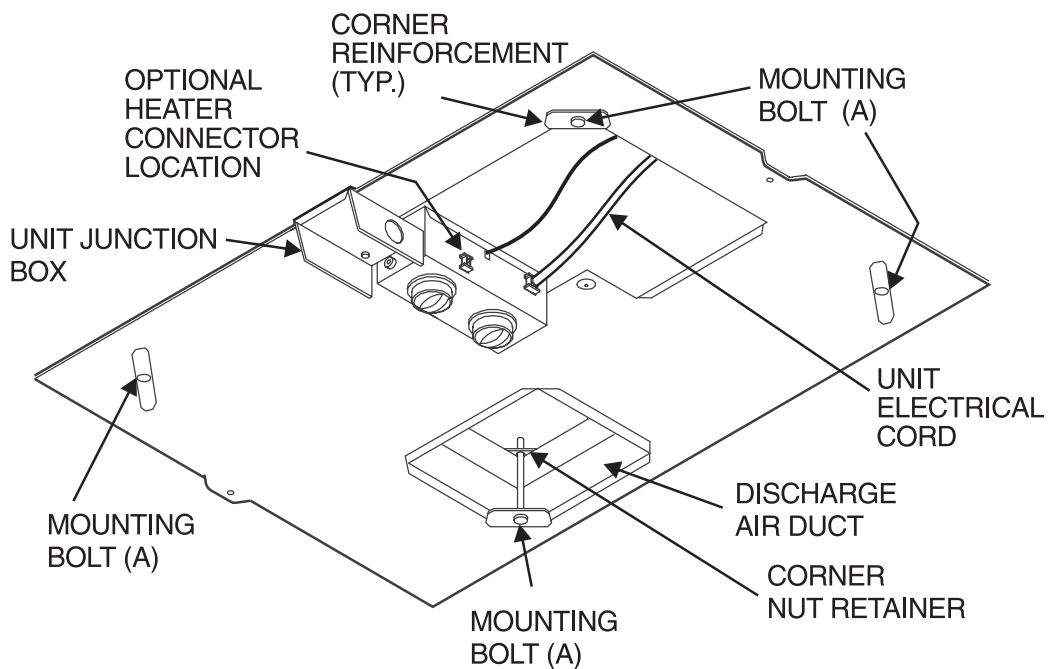

EVENLY TIGHTEN MOUNTING BOLTS TO A TORQUE OF 40 TO 50 INCH POUNDS.

This will compress the roof gasket to approximately 1/2". The bolts are self locking so over tightening is not necessary.

5. Install four (4) wood screws (B) that hold air box tight to ceiling if so desired.
6. Reinstall return air grille and filter into air box.
7. The air conditioner installation is now complete. Turn on power to the unit for operational check. Please read Unit Operating Instructions before proceeding.

## F. CONNECTION OF POWER SUPPLY

**NOTE: All wiring must comply with the National Electrical Code and any State or Local Codes or regulations.**

1. Route supply line into junction box thru provided Romex Connector (D). Six (6) inch leads are sufficient for connection to unit wires and ground screws.
2. Connect white wire in junction box to white or neutral wire from supply line.
3. Connect black wire in junction box to black or hot wire from supply line.
4. Connect supply ground wire to identified ground screw in junction box.

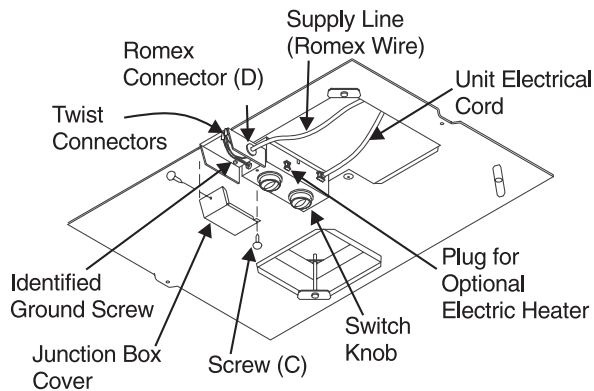

5. Install junction box cover with two (2) blunt point screws (C).
6. Plug unit electrical cord into the mating connector on control box.

## G. INSTALL AIR BOX

1. Remove return air grille from air box by pulling in on half-round finger catches.
2. NOTE: If optional heat package is to be installed, do so at this time, before the air box is installed. Follow instructions with heat package for its installation procedure.
3. Hold air box up to ceiling template and install three (3) #10 x 3/8" screws at air box mounting point.
4. Snap hole plug (E) into place at rear of air box.

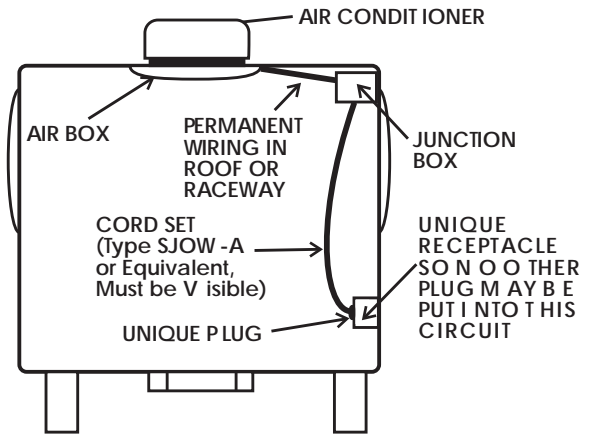
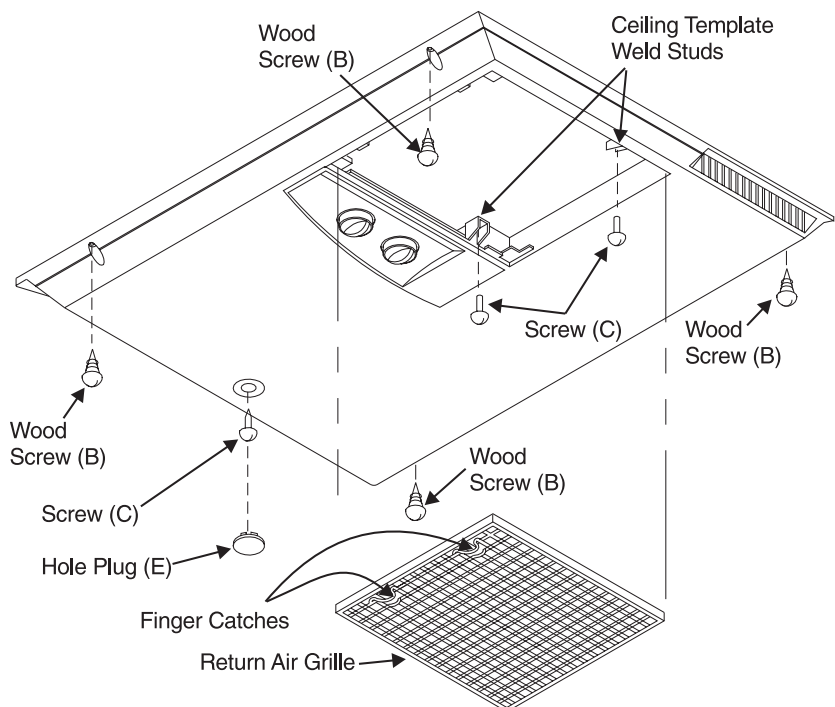

## H. INSTALLATION ON TENT CAMPER ROOF

1. The permanent wiring leading to unit junction box may originate in a flanged surface inlet located in roof section near the side wall.
2. A unique outlet receptacle for air conditioner should be located in the side wall of vehicle beneath the flanged surface inlet.
3. A cord set fabricated from an oil, water, and ozone resistant material, such as Type SJOW-A, shall be used to connect the flanged surface inlet and the air conditioning receptacle. This cord set shall be visible during use and shall not be installed in raceways or placed behind walls or cabinet panels.