

Dometic®

MICROWAVE OVEN

OWNER'S GUIDE



LISTED



LISTED

To help you get the
most out of your
new appliance

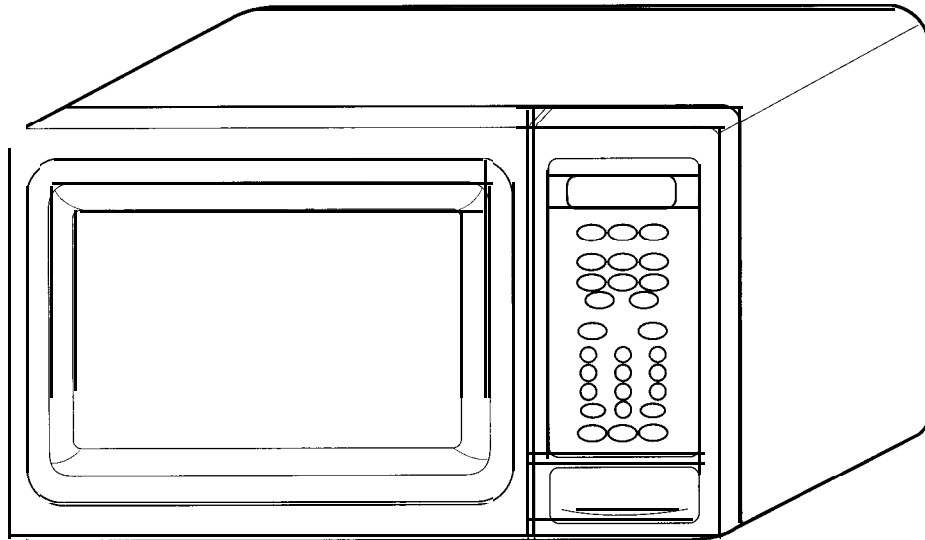

**MODEL NO.: CDMW10MW
CDMW10MB**

P/No.:3828W5A1688

TABLE OF CONTENTS

| | |
|--|--------|
| Precautions to Avoid Possible Exposure to Excessive Microwave Energy | .2 |
| Technical Specifications | 3 |
| Federal Communications Commission Radio Frequency Interference Statement.. | .3 |
| Important Safety Instructions.. | .4 |
| Installation.. | 5-6 |
| Feature Diagram | 7 |
| Control Features.. | 8 |
| Operating Instructions.. | 9-18 |
| • Setting Clock | 9 |
| • Child Lock.. | 9 |
| • Timer | 10 |
| • Plus Minute.. | 10 |
| • One Touch Reheat.. | 11 |
| • One Touch Cook | 12 |
| @Auto Defrost | 13-14 |
| • Time Cooking | 15 |
| • Using Multi-Power Levels | .16 |
| • Automatic Popcorn.. | 17 |
| • Multi-Stage Cooking | 18 |
| Vegetable and Rice.. | 19 |
| Meats, Poultry and Fish | .20-22 |
| Baked Goods and Desserts.. | .23 |
| Auto Defrost Chart | 24-25 |
| Conversion Table.. | 25 |
| Precautions | 26 |
| Questions and Answers.. | 26 |

PRECAUTIONS TO AVOID POSSIBLE EXPOSURE TO EXCESSIVE MICROWAVE ENERGY

- (a) Do not attempt to operate this oven with the door open-since open-door operation can result in harmful exposure to microwave energy. It is important not to defeat or tamper with the safety interlocks.
- (b) Do not place any object between the oven front face and the door or allow soil or cleaner residue to accumulate on sealing surfaces.
- (c) Do not operate the oven if it is damaged. It is particularly important that the oven door close properly and that there is no damage to the:
 - (1) Door (bent),
 - (2) hinges and latches (broken or loosened),
 - (3) door seals and sealing surfaces.
- (d) The oven should not be **adusted** or repaired by anyone except properly qualified service personnel.

TECHNICAL SPECIFICATIONS

| | |
|-----------------------------------|---|
| MODEL | CDMW1 0MW/CDMW1 OMB |
| Power Supply | 120V AC., 60Hz |
| Rated Power Consumption | 1,500W |
| Microwave Output | ● 1 000W |
| Frequency | 2,450MHz |
| Rated Current | 13 A |
| Overall Dimensions (WXHxD) | 20 ¹ / ₈ " x 12" x 15 ⁵ / ₁₆ " |
| Oven Cavity Dimensions (WXHxD) | 13 ³ / ₈ " x 8 ⁷ / ₈ " x 14 ¹ / ₈ " |
| Effective Capacity of Oven Cavity | 1.1Cu.ft. |

*IEC 705 RATING STANDARD

Specifications subject to change without prior notice.

The serial number is found on the back of this unit. This number is unique to this unit and not available to others. You should record requested information here and retain this guide as a permanent record of your purchase.

Date of Purchase

Dealer Purchased From

Dealer Address

Dealer Phone No.

Model No.

Serial No.

FEDERAL COMMUNICATIONS COMMISSION RADIO FREQUENCY INTERFERENCE STATEMENT (U.S.A ONLY)

WARNING:

This equipment generates and uses ISM frequency energy and if not installed and used properly, that is in strict accordance with the manufactures' instructions, may cause interference to radio and television reception.

It has been type tested and found to comply with limits for a ISM Equipment pursuant to part 18 of FCC Rules, which are designed to provide reasonable protection against such interference in a residential installation.

-**however**, there is no guarantee that interference will not occur in particular installation.

If this equipment does cause interference to radio or television reception, which can be determined by turning the equipment off and on, the user is encouraged to try to correct the interference by one or more of the followings:

- ▶ Reorient the receiving antenna of radio or television.
- ▶ Relocate the microwave oven with respect to the receiver.
- ▶ Move the microwave oven away from the receiver.
- ▶ Plug the microwave oven into a different outlet so that microwave oven and receiver are no different branch circuits.

THE MANUFACTURER is not responsible for any radio TV interference caused by UNAUTHORIZED MODIFICATION to this microwave oven. It is the responsibility of the user to correct such interference.

IMPORTANT SAFETY INSTRUCTIONS

WARNING ■ To reduce the risk of burns, electric shock, fire, injury to persons or exposure to excessive microwave energy:

1. Read all instructions before using the appliance.
2. Read and follow the specific **“PRECAUTIONS TO AVOID POSSIBLE EXPOSURE TO EXCESSIVE MICROWAVE ENERGY”** found on page 2 of this manual.
3. This appliance must be grounded. Connect only to properly grounded outlet.
See **“GROUNDING INSTRUCTIONS”** found on page 5 of this manual.
4. Install or locate this appliance only in accordance with the provided installation instructions.
5. Some products such as whole eggs and sealed containers-for example, closed glass jars-may explode and should not be heated in this oven.
6. Use this appliance only for its intended use as described in this manual. Do not use for drying linens, newspaper, or any other non food items.
7. As with any appliance, close supervision is necessary when used by children.
8. Do not operate this appliance if it has a damaged cord or plug, if it is not working properly, or if it has been damaged or dropped.
9. This appliance should be serviced only by qualified service personnel only. Contact nearest Service centre for any inspection, repair or adjustment.
10. Do not cover or block any openings on the appliance.
11. Do not use outdoors.
12. Do not immerse cord or plug in water.
13. Keep the cord away from heated surfaces.
14. Do not let the cord hang over the edge of a table or a counter.
15. When cleaning surfaces of door and oven use only mild, non-abrasive soaps or detergents applied with a sponge or soft cloth.
16. To reduce the risk of fire in the oven cavity:
 - a. Do not overcook food. Watch carefully if paper, plastic or other combustible materials are placed inside the oven.
 - b. Remove wire twist-ties from paper or plastic bags before placing bag in oven.
 - c. If materials inside the oven should ignite, **KEEP THE OVEN DOOR CLOSED**, turn oven off, and disconnect the power cord, or shut off power at the fuse or circuit breaker panel.
17. Do not heat any type of baby bottles or baby food. Uneven heating may occur and could cause personal injury.
18. Avoid heating small-necked containers such as syrup bottles.
19. Avoid using corrosive and vapors, such as sulfide and chloride, such as syrup bottles.
20. Liquids heated in certain shaped containers (especially cylindrical-shaped containers) may become overheated. The liquid may splash out with a loud noise during or after heating or when adding ingredients (instant coffee, etc.) resulting in harm to the oven and possible injury. In all containers, for best results, stir the liquid several times before heating. Always stir liquid several times between reheatings.

SAVE THESE INSTRUCTIONS

INSTALLATION

A. GROUNDING INSTRUCTIONS

For personal safety, this appliance must be properly grounded.

In the event of an electrical short circuit, grounding reduces the risk of electric shock by providing an escape route for the electric current.

The power cord of this appliance is equipped with a three-prong (grounding) plug (Fig. 1) to minimize the possibility of electric shock hazard from this appliance.

The plug must be plugged into an outlet that is properly installed and grounded.

WARNING—Improper use of the grounding plug can result in a risk of electric shock. Do not, under any circumstances, cut or remove the third ground prong from the power cord plug.

PROPERLY POLARIZED AND GROUNDED OUTLET

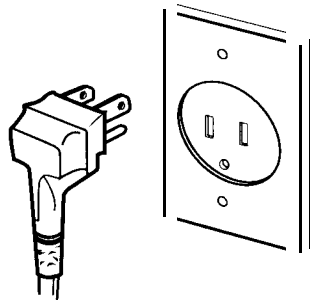

Three-Pronged (Grounding) plug Fig. 1

The consumer should have it checked by a qualified electrician or serviceman if the grounding instructions are not completely understood, or if doubt exists as to whether the appliance is properly grounded. Where a standard two-prong wall receptacle is encountered, it is the responsibility and obligation of the consumer to have it replaced with a properly grounded three-prong wall receptacle.

- a) If customer has two-prong wall receptacle, he should replace it with a three-prong (grounding) receptacle by a qualified electrician before using the appliance.
- b) Use of extension cords: If it is necessary to use an extension cord, use only a 3-wire extension cord that has a 3-blade grounding plug, and a 3-slot receptacle that will accept the plug on the appliance. The marked rating of the extension cord should be equal to or greater than the electrical rating of the appliance.

INSTALLATION (Cont'd)

B. CIRCUITS

For safety purposes this oven must be plugged into a 20 Amp circuit. No other electrical appliances or lighting circuits should be on this line. If in doubt, consult a licensed electrician.

C. VOLTAGE WARNING

The voltage used at the wall receptacle must be the same as specified on the oven serial plate located on the back or on the side of the control panel of the oven. Use of a higher voltage is dangerous and may result in a fire or other type of accident causing oven damage. Low voltage will cause slow cooking. In case your microwave oven does not perform normal operation in accordance with AC power source and voltage, remove the power cord and then insert it again.

D. DO NOT BLOCK AIR VENTS

All air vents should be kept clear during cooking. If air vents are covered during oven operation the oven may overheat. In this case a sensitive thermal safety device automatically turns the oven off. The oven will be inoperable until it has cooled sufficiently.

E. RADIO INTERFERENCE

1. Operation of the microwave oven may cause interference to your radio, TV or similar equipment.
2. When there is interference, it may be reduced or eliminated by taking the following measures:
 - a. Clean door and sealing surfaces of the oven.
 - b. Reorient the receiving antenna of radio or television.
 - c. Relocate the microwave oven with respect to the receiver.
 - d. Move the microwave oven away from the receiver.
 - e. Plug the microwave oven into a different outlet so that microwave oven and receiver are on different branch circuits.

NOTE:

1. Short power-supply cord is provided to reduce the risks resulting from becoming entangled in or tripping over a longer cord.
2. Longer cord sets or extension cords are available and may be used if care is exercised in their use.
3. If long cord or extension cord is used, (1) the marked electrical rating of the cord set or extension cord should be at least as great as the electrical rating of the appliance, (2) the extension cord must be a grounding-type 3-wire cord, and (3) the longer cord should be arranged so that it will not drape over the countertop or tabletop where it can be pulled on by children or tripped over accidentally.

FEATURE DIAGRAM

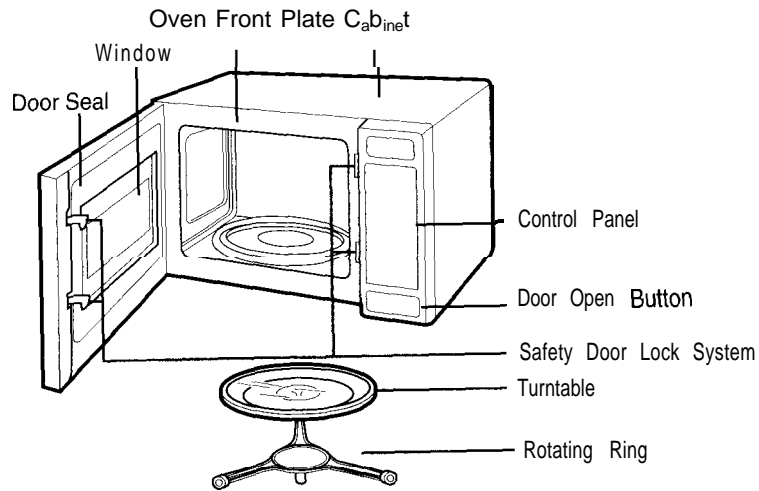

Remove your Microwave Oven and all material from the shipping carton.
Your oven will be packed with the following material:

| | |
|---------------------|--------|
| Turntable | 1 each |
| Owner's Guide | 1 each |
| Rotating Ring | 1 each |

INSTALLATION

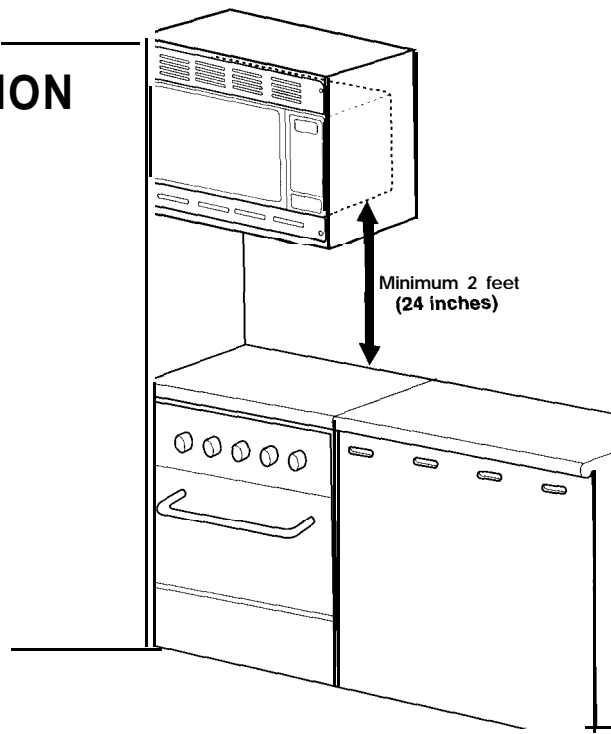

CONTROL FEATURES

ONE TOUCH COOK

Automatically determines time requirement to cook food easily.

POPCORN

Used to cook prepackaged microwave popcorn.

AUTO DEFROST

Used to set Automatic Defrost by Weight.

LBS/KG

Used to select the weight of the foods for Auto Defrost functions.

TIME

Used to set manual time cooking.

CLOCK

Used to set clock.

CLEAR

Clears all previous settings if pressed before cooking starts. During cooking: touch once to stop oven; twice to stop and clear all entries except clock.

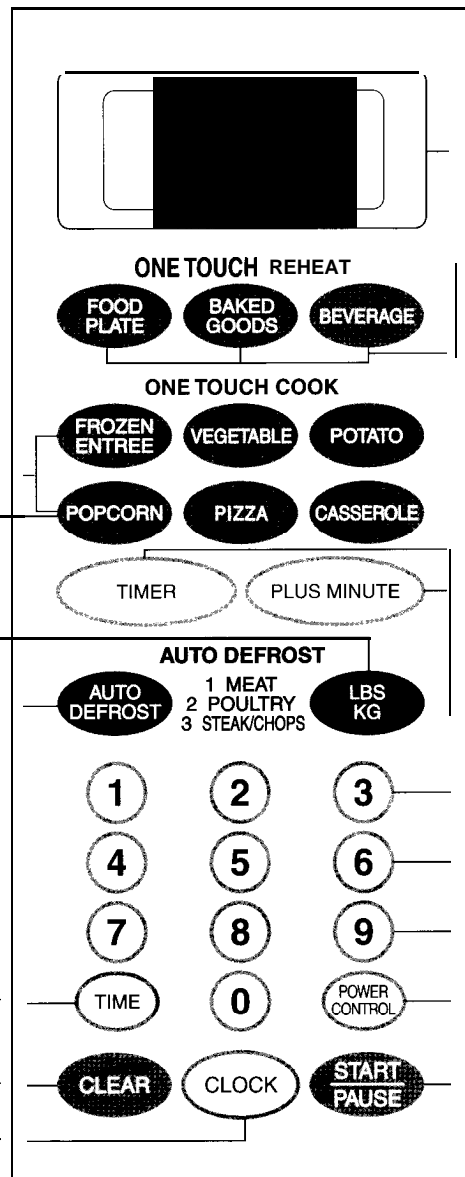

DISPLAY WINDOW

Shows program selections and displays cooking modes.

-ONE TOUCH REHEAT

Automatically determines time requirement to reheat food and beverage.

PLUS MINUTE

Used to quick set and start microwave cooking without the need to touch START.

-TIMER

Touch this pad to use your microwave oven as a kitchen timer.

-Number Key Pads

Used to set time and power level.

POWER CONTROL

Used to set cooking power levels.

-START/PAUSE

Starts the oven.

OPERATING INSTRUCTIONS

1. SETTING CLOCK

When your oven is plugged in for the first time or when power resumes after a power interruption the numbers in the display reset to 0.

To set the time of day :

1. Touch **CLEAR**.

A button with the word "CLEAR" inside an oval border.

2. Touch **CLOCK**.

A button with the word "CLOCK" inside an oval border.

3. Enter the time by using the number key pads.

Example: To set 3:15, touch number key pads **[3],[1]** and **[5]**.



4. Touch **CLOCK**.
The clock starts counting.

A button with the word "CLOCK" inside an oval border.

If the clock (or display) shows any abnormality, unplug the oven from the AC outlet, plug it back in and then reset the clock.

2. CHILD LOCK

This is a unique safety feature that prevents accidental running of the oven. Once the child lock-out is set, no cooking can take place.

When the child lock-out is set, you can't input any key.

To set:

1. Touch **CLEAR**

A button with the word "CLEAR" inside an oval border.

2. Touch and hold 0 until "Loc" appears in the display.

A circular button with the number 0 inside.

To cancel child lock-out :

1. Touch and hold 0 until "Loc" disappears in the display.
2. The time of day returns to the display window.

A circular button with the number 0 inside.

OPERATING INSTRUCTIONS(Cont'd)

3. TIMER

Your microwave oven can be used as a kitchen timer.
You can Set up to 99 minutes, 99 seconds.

EXAMPLE : To set 3 minutes.

1. Touch **TIMER**.



2. Enter 3 minutes by touching **[3]**,
[0],**[0]**



3. Touch **TIMER**
The time starts counting.



4. PLUS MINUTE

This time-saving feature lets you cook at 100% power for up to 99 minutes, 59 seconds, 1 minute is added to the cook time each time you press PLUS MINUTE.

EXAMPLE : To set **ADD** 30 cooking for 1 minute.

1. Touch **PLUS MINUTE**.
At the end of the cook time, four tones will sound.



OPERATING INSTRUCTIONS(Cont'd)

5. ONE TOUCH REHEAT

Three preset categories for microwave reheating have been included in the ONE TOUCH REHEAT menu.

1. Food Plate
2. Baked Goods
3. Beverage

Auto Reheat Tips

- Foods must be at room or refrigeration temperature.
- Follow the directions included in the menu.
- When reheating food on a plate, place larger and denser food near the outer edge of the plate.
- Stir food after reheating.

EXAMPLE : To reheat FOOD PLATE, follow the steps below.

1. Touch **CLEAR**



2. Touch **FOOD PLATE**, until the desired quantity appears in the display window. For example, when "FOOD PLATE" is touched twice, "2" will show in the display window (only 1 serving or 2 servings can be reheated at one time).



The oven will begin the reheating you selected without the need to touch START.

ONE TOUCH REHEAT CHART

| Category | Serving | Quantity | Direction |
|-------------|--|------------------------|---|
| Food Plate | Plate of Food (Refrigerated, precooked food) | 1 serving (8oz-230g) | Use a microproof plate. Cover tightly with wax paper. Use one plate for 1-2 servings. |
| | | 2 servings (16oz-454g) | Examples of one serving for a Plate of Food: 1 chicken breast, (4 oz-115g), 1/4 cup vegetables, 1/4 cup mashed potatoes or (4 oz-115g) precooked meatloaf, 1/4 cup cooked vegetables. |
| Baked Goods | Baked Goods (RoomTemp. Food) | 1 piece | Place in the center of the oven on a paper towel. |
| | | 2 pieces | |
| | | 3 pieces | |
| | | 4 pieces | |
| Beverage | Coffee/Tea (Refrigerated Temp) | 1 cup (8oz-227mL) | No cover. Use uncovered microproof cup(s) or mug(s). Stir after reheating. |
| | | 2 cups (16 oz-454mL) | |

OPERATING INSTRUCTIONS(Cont'd)

6. ONE TOUCH COOK

One Touch Cook made easy!
Your oven's menu has been preprogrammed to automatically cook food.

Tell the oven what you want and how many items there are.

Then let your microwave oven cook your selections.

Food items in the One Touch Cook menu include:

1. Frozen Entree
2. Vegetable
3. Potato
4. Popcorn
5. Pizza
6. Casserole

EXAMPLE : To cook FROZEN ENTREE, simply follow the steps below.

1. Touch **CLEAR**.

CLEAR

2. Touch **FROZEN ENTREE**.

FROZEN ENTREE

The oven begins the cooking you selected without the need to touch START.

ONE TOUCH COOK CHART

| Category | Serving | Quantity | Direction |
|---------------|-----------|--|---|
| FROZEN ENTREE | 1 Serving | 10 oz.(280g) | Remove package from wrapper. Follow 1 package instructions for microwaving. Place entree on a microwave plate. Cover tightly with wax paper. Examples of one frozen dinner are Lasagna with Meat Sauce, Chicken with Rice and Sliced Turkey Breast with Rice. |
| VEGETABLE | 1 cup | 8 oz.(230g) Vegetables and 2 tbsp water | Cover with microwave safe, plastic wrap. |
| | 2 cups | 16 oz.(454g) Vegetables and 1/4 cup water | Cover with microwave safe, plastic wrap. |
| | 3 cups | 24 oz.(680g) Vegetables and 1/3 cup water | Cover with microwave safe, plastic wrap. |
| | 4 cups | 32 oz.(900g) Vegetables and 1/2 cup water | Cover with microwave safe, plastic wrap. |
| | | | Prepare vegetable(wash, cut-up vegetables into 1/2-inch (1"-2.5cm) slices or pieces.). Place in microproof bowl or casserole. Add water. Cover. Most vegetables profit from 2 to 3 minutes standing time after cooking. Note : Fresh vegetable weight is given after peeling, trimming, slicing. etc. |
| POTATO | | 8 oz.(280g) 16 oz.(560g) 24 oz.(840g) 32 oz.(1120g) | Wash and scrub well. Pierce with fork. Place on microproof rack or paper towel in a circle (1"-2.5cm), apart. Let stand 3 to 5 minutes after cooking. |
| POPCORN | | 3.5 oz. (1 00g) 3.0 oz. (85g) 1.75 oz. (50g) | Place bag on turntable. Follow manufacturer's instructions. |
| PIZZA | 1 Slice | 5 oz.(142g) | Place the refrigerated pizza on the plate in the center of the microwave oven. |
| | 2 Slices | 10 oz.(280g) | |
| | 3 Slices | 15 oz.(426g) | |
| CASSE-ROLE | | 1 cup 2 cups 3 cups 4 CUPS | Place in the center of the oven. Cover with plastic wrap and vent. |

OPERATING INSTRUCTIONS(Cont'd)

7. AUTO DEFROST

The Auto Defrost by Weight feature is an accurate defrosting method for frozen meat, poultry and fish up to 6.0lbs or 4.0kgs.

The oven automatically determines required defrosting times for each food item according to the weight you enter.

Simply tell the oven the type of your frozen food and enter the food weight. The oven calculates the rest.

For added convenience, the Auto Defrost by Weight Feature contains a built-in beep mechanism that lets you check, turn over, separate or rearrange as recommended in the Auto Defrosting chart in SECTION 5.

Three different defrosting levels are provided:

1. **MEAT**
2. **POULTRY**
3. **STEAK/CHOPS**

If you wish to change the unit of weight, touch the LBS/KG pad after the defrost menu and weight is selected, and then select the weight by touching the number key.

EXAMPLE : To defrost 1.2lbs of ground beef, select Meat Menu and enter the weight.

1. Touch **CLEAR**.



2. Touch **AUTO DEFROST** once. **DEF1** appears in the display.



3. Enter the weight by touching **[1]** and **[2]**. **1.2LB** appears in the display.

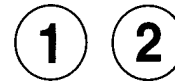

You can change the unit of weight, by touching LBS/KG pad.

4. Touch **START/PAUSE**.
Defrosting starts.
The display changes to defrost time count down.



The oven will beep during the DEFROST cycle. At this time, open the door, and turn, separate, or rearrange the food. Remove any portions that have thawed. Return frozen portions to the oven and touch START to resume the defrost cycle. The oven will not STOP during the BEEP unless the door is opened.

OPERATING INSTRUCTIONS(Cont'd)

7. AUTO DEFROST(Cont'd)

- To enter a weight of less than 1 lb always press the weight directly. For example, to enter 0.2 lbs, press [2].
- As only one digit can be entered after the decimal point, round figures off to the lower number to avoid overdefrosting. For example, for 1.28 lbs, use 1.2.
- For best results, check the food during defrosting.
- Remove fish / seafood / meat / poultry from its original paper or plastic package (wrapper). Otherwise, the wrap will trap steam and juice, which can cause the surface of the foods to cook.
- When it is difficult to remove the wrap from the food, defrost the wrapped food for about a quarter of the total defrost time, which is displayed at the beginning of the defrost cycle. Then remove the food from oven, and remove the wrap from food.
- Place foods in a flat microwave-safe baking dish or microwave roasting rack to catch drippings.
- Food should still be somewhat icy in the center when removed from the oven.
- Standing time is included in each Auto Defrost menu.

| | Food | Min. / Max. Food |
|--------------------|--------------|------------------|
| MEAT | Beef | |
| | Pork | 0.1 / 6.0 lbs |
| | Veal | (0.1 / 4.0 kg) |
| | Variety Meat | |
| | Lamb | |
| POULTRY | Chicken | 0.1 / 6.0 lbs |
| | Cornish Hens | (0.1 / 4.0 kg) |
| | Duck | |
| | Turkey | |
| STEAK/CHOPS | Fish | 0.1 / 6.0 lbs |
| | Seafood | (0.1 / 4.0 kg) |

MANUAL DEFROST

To speed up the defrosting of dense food items over 1 lb. (450g), you may start on **HI**, then reduce to the 30% power setting.

1. Microwave on **HI** for 1-2 minutes per pound of dense food items.
2. Then microwave on 3 (30%) for 3 minutes per pound or until food is thawed. Defrosting time will be greatly reduced.

AUTO DEFROST

This oven also offers an Auto Defrost by Weight menu, which is especially preprogrammed to defrost meat, poultry and steak/chops at different power level combinations.

OPERATING INSTRUCTIONS(Cont'd)

8. TIME COOKING

This basic microwave cooking method allows you to cook food for a time period that you determine.

Set the time, and press START/PAUSE. Your oven begins cooking using its maximum power (HI POWER)

Foods with high moisture content should be cooked on maximum power, as this is the fastest cooking method and best maintains the natural flavour and texture of the foods.

1. Touch **CLEAR**.



2. Touch **TIME**.



3. Enter desired time in minutes and seconds by touching the number pads.



Examples:

To set 3-1/2 minutes, touch **[3]**, **[3]** and **[0]**.

4. Touch **START**.



OPERATING INSTRUCTIONS(Cont'd)

9. USING MULTI-POWER LEVELS

For foods requiring slower cooking, your oven also provides 10 different power settings.

The Multi-Power feature lets you choose a lower power level over the automatic HI (maximum oven power), so that food can be cooked more slowly.

Refer to the Multi-Power Setting Guide for the most suitable cooking level of various foods.

EXAMPLE: To cook at power level 8 (80%) for 45 seconds.

1. Touch **CLEAR**.



2. Touch **TIME**.



3. Enter 45 seconds by touching **[4]** and **[5]**. 45 appears in the display.



4. Touch **POWER CONTROL**. **P-HI** appears in the display. This is to tell you that the oven is set on HI unless a different power setting is chosen.



5. Touch **[8]** to select power level 8. Display shows P-80.



6. Touch **START/PAUSE**. When the cooking time is over, the oven shuts itself off.



MULTI-POWER SETTING GUIDE

| NUMBER KEY PAD | POWER LEVEL | COOKING EXAMPLES |
|----------------|-------------|---|
| 1 | 10 | Softening cream cheese. Keeping casseroles and main dishes warm. |
| 2 | 20 | Softening chocolate. Heating breads, rolls, pancakes, tacos, tortillas and French toast. Clarifying butter. Taking the chill off fruit. Heating small amounts of food. |
| 3 | 30 | Thawing bread, small quantity of most food. Completing the cooking cycle of casseroles, stews and sauces. Cooking small quantities of most food. |
| 4 | 40 | Cooking less tender cuts of meat in liquid or slow-cooking dishes. Completing the cooking cycle of less tender roasts. |
| 5 | 50 | Cooking stews and soups after bringing to a boil. Cooking baked custards and pasta. |
| 6 | 60 | Cooking scrambled eggs. Baking cakes. |
| 7 | 70 | Cooking rump roast, ham, veal and lamb. Cooking cheese dishes. Cooking eggs and milk. |
| 8 | 80 | Reheating precooked or prepared food quickly. |
| 9 | 90 | Cooking onions, celery and green peppers quickly. Reheating meat slices quickly. |
| Is Automatic | H I | Cooking poultry, fish, vegetables and most casseroles. Preheating the browning dish. Boiling water. |

OPERATING INSTRUCTIONS(Cont'd)

11. AUTOMATIC POPCORN

This feature makes preparation of microwave popcorn simple and quick... **one bag at a time.**

The automatic popcorn uses the HI power only.

The popping time counts down in the display.

The popping begins about one minute after POPCORN is pressed.

When the popping time is over, **END** appears on the display. Oven shuts off automatically.

Place one bag of prepackaged microwave popcorn on the turntable. The package should be at room temperature.

1. Touch **CLEAR**.

A button labeled "CLEAR" inside an oval border.

2. Touch **POPCORN**.

A button labeled "POPCORN" inside an oval border.

The oven will begin the cooking you selected without the need to touch **START/PAUSE**

3. Open bag carefully. Popcorn and steam are extremely **hot**. Open bag by pulling top diagonal corners to avoid escaping steam.

NOTE : This feature is composed of three servings. You can select the quantity by touching the key once (3.5 oz.), twice (3.0 oz.) or three times (1.75 oz.).

NOTE :

- If popcorn bag size is not known, follow manufacturers' instructions and do not use this feature.
- Do not use POPCORN key pad in combination with any other feature key pads.
- Do not attempt to reheat or cook any unpopped kernels.
- Do not reuse bag. Overcooking can result in an oven fire.
- Prepare one bag only at a time.
- Do not use popcorn popping devices in microwave oven with this feature.
- Do not leave microwave unattended while cooking popcorn.

CAUTION : Never use a brown paper bag for popping corn.

OPERATING INSTRUCTIONS(Cont'd)

12. MULTI-STAGE COOKING

Multi-stage cooking lets you program up to three different cooking stages in advance each stage with a different power level and time settings.

When START is pressed, the oven begins the first stage and automatically proceeds to the second and the third stages.

Two beeps sound between stages.

When all programmed stages are over, two short and one long tones sound and END shows in the display window.

- To stir, turn over or rearrange food, you can open the door anytime during cooking. This will not change the setting.

EXAMPLE: To set a 2-Stage Cook cycle.

First Stage (10 minutes, power level: HI)

1. Touch **CLEAR**.



2. Touch **TIME**.



3. Enter 10 minutes by touching **[1], [0], [0] and [0]**.
(Power is at **HI**)

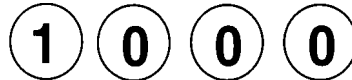

Second Stage (8 minutes, power level: 7 (70%))

4. Touch **TIME**.



5. Enter 8 minutes by touching **[8], [0], and [0]**.

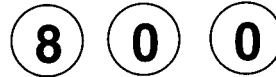

6. Touch **POWER CONTROL**.



7. Touch number **[7]**.



8. Touch **START/PAUSE**.



VEGETABLE AND RICE

Directions for Cooking Vegetables

Fresh

Place vegetables in casserole. Add amount of water recommended in chart. Cover with lid or plastic wrap. Whole vegetables, such as potatoes, or eggplant should be pierced with a fork several times before cooking.

Halfway through cooking, stir, rearrange and/or turn vegetables over.

Let stand, covered, before serving.

Frozen

For 1 0-ounce (300g) package, place vegetables in 4 to 6 cup (1 or 1.5L) casserole.

Add amount of water according to package directions.

Cover with lid. Cook at HIGH 6 to 10 minutes, or until tender. Stir two-thirds the way through cooking.

Let stand, covered, before serving.

Fresh Vegetable Chart

| VEGETABLE | AMOUNT | WATER | APPROX. COOKING TIME at HIGH (in minutes) |
|--|---------------|-----------------|--|
| Asparagus, spears | 1 lb (450g) | 1/2 cup (125mL) | 4 to 7 |
| Beans, Green or Wax, cut into 1 1/2-in. (4cm) pieces | 1 lb (450g) | 1/2 cup (125mL) | 8 to 11 |
| Broccoli, cut in pieces | 1 lb (450g) | 1/2 cup (125mL) | 5 to 7 |
| Brussels Sprouts, fresh | 10 oz. (300g) | 1/4 cup (50mL) | 5 to 7 |
| Cabbage, wedges, fresh | 1 lb (450g) | 1/2 cup (125mL) | 5 to 7 |
| Carrots, sliced 1/2-in. (1 cm) thick | 1 lb (450g) | 1/2 cup (125mL) | 5 to 7 |
| Cauliflower, florets | 1 lb (450g) | 1/2 cup (125mL) | 5 to 7 |
| Eggplant, whole, fresh | 1 lb (450g) | 1/2 cup (125mL) | 6 to 10 |
| Leeks, whole, fresh | 1 lb (450g) | 1/2 cup (125mL) | 8 to 11 |
| peas, fresh | 1 lb (450g) | 1/2 cup (125mL) | 6 to 9 |
| Potatoes, whole, fresh | 4 (8oz. ea.) | 1/2 cup (125mL) | 13 to 16 |
| Spinach, fresh | 1 lb (450g) | 1/2 cup (125mL) | 7 to 9 |
| Turnips, cubed, fresh | 1 lb (450g) | 1/2 cup (125mL) | 9 to 12 |

Cooking Guide - Rice

| ITEM | CONTAINER | AMOUNT OF WATER | POWER (%) | APPROX. COOKING TIME (in minutes) | STAND TIME (In minutes) | SPECIAL NOTES |
|---|--|-----------------------|-----------|-----------------------------------|-------------------------|---|
| Rice* Flavored Rice Mix 6 oz (170g) | 8 cup (2L) casserole | as package directs | 7 (70) | 14 to 30 | 10 | Cover and heat water to a boil (5 to 7 min.). |
| Long Grain | 8 cup (2L) 1 cup (250mL) casserole | 2 cups (500mL) | 5 (50) | 13 to 16 | 10 | Add rice, salt and butter (amount of salt and butter as package |
| Short Grain | 8 cup (2L) 1 cup (250mL) casserole | 2 cups (500mL) | 5 (50) | 9 to 12 | 10 | directs). Cook covered, stir, let stand, covered. |

MEATS, POULTRY AND FISH

Directions for Cooking Meats, Poultry and Fish

Use fresh or defrosted meat, poultry and fish. Wash poultry or fish before cooking. Arrange small items in a single layer in dish. For best results, avoid overlapping edges of food, as this will prevent even cooking. Place thick sections toward edge of the dish. A rack in the cooking dish will elevate meat out of the juices. Season as desired, but salt after cooking. Kitchen bouquet mixed with equal parts of butter will enhance the color of meats and poultry. Use spices and seasonings as desired. Shield thin parts of meat (less meaty portions) or poultry (wings and legs) with aluminum foil to prevent overcooking. Shield poultry before cooking; shield meat halfway through cooking. Wooden toothpicks can be used to hold the foil in place. Cook according to directions in chart. Small quantities of sauce will not alter the cooking time. Test for doneness before adding extra cooking time. Remove roasts from oven then check internal temperature in several places, using a microwave or conventional meat thermometer.

The thermometer should not touch bone or fat. If it does, the reading could be inaccurate. Generally, the lower temperatures in a roast are found in the center of the roast and in the muscle close to a large bone, such as a pork loin center rib roast.

DO NOT USE A CONVENTIONAL MEAT THERMOMETER IN THE MICROWAVE OVEN.

To test beef for doneness, cut into meat. Red color indicates rare, pink indicates medium and gray indicates well done. Pork is done when meat is gray with clear juices. Whole poultry is done when juices are clear yellow and drumstick moves freely. Poultry pieces are cooked when juices are clear **yellow**. Fish and seafood are done when opaque in color and flake easily when tested with a fork. If foods are undercooked, return to oven for a short period of time at the recommended power level. Let stand for time recommended in chart. Roasts and whole birds should be tented with foil during stand time.

| FOOD | POWER (%) | APPROX. COOKING TIME (in minutes) | STAND TIME (in minutes) | SPECIAL NOTES |
|---|-----------|-----------------------------------|-------------------------|---|
| Beef | | | | |
| Hamburgers, Refrigerated 4 oz ea. (120g) | | | | Place meat in a shallow dish. Cover loosely with waxed paper to prevent spattering. |
| 1 | HIGH | 1 1/2 to 2 | 2 | Turn over halfway through cooking. |
| 2 | HIGH | 2 to 4 | 2 | |
| 4 | HIGH | 3 to 5 | 2 | |
| Hamburgers, Frozen 4 oz ea. (120g) | | | | |
| 1 | HIGH | 4 to 5 1/2 | 2 | Turn over and separate halfway through cooking. |
| 2 | HIGH | 6 to 7 | 3 | |
| 4 | HIGH | 9 to 11 | 3 | |
| Meat Loaf 1 1/2 lbs (675g) | 5 (50) | 18 to 23 | 5 | Arrange in loaf dish. Cover with waxed paper. |
| Roasts, Tender 1 lb (450g) | 8 (80) | | | |
| Rare | | 7 to 9 | 10 to 15 | Place in a square dish. Cover with waxed paper. |
| Medium | | 7 to 9 | 10 to 15 | Shield halfway through cooking and turn roast over if necessary. |
| Well | | 8 to 10 | 10 to 15 | Tented with foil |
| | | | | *Approx. temp. after stand Rare 130°F (55°C) Medium 140°F (60°C) Well 170°F (77°C) |

MEATS, POULTRY AND FISH(Cont'd)

| FOOD | POWER (%) | APPROX. COOKING TIME (in minutes) | STAND TIME (in minutes) | SPECIAL NOTES |
|--|-----------|-----------------------------------|-------------------------|---|
| Pork | | | | |
| Bacon, Slices | | | | Use bacon rack or line bottom of dish with paper towel. Place bacon on paper towel. Cover loosely with another paper towel to prevent spattering. |
| 1 | HIGH | 1 to 1 1/2 | 1 | |
| 2 | HIGH | 1 1/2 to 3 | 1 | |
| 4 | HIGH | 2 to 4 | 1 | |
| Chops, Loin 1/2-inch (1 cm) thick | | | | Place in a shallow dish. Cover loosely with waxed paper to prevent spattering. Turn over at half the cooking time. |
| 1 | HIGH | 3 to 6 | 2 | |
| 2 | HIGH | 7 to 9 | 5 | |
| Chops, Rib 1/2-inch (1cm) thick | | | | |
| 1 | HIGH | 3 to 5 | 2 | |
| 2 | HIGH | 5 to 6 | 5 | |
| 4 | HIGH | 8 to 10 | 5 | |
| Wieners | | | | Score before cooking. |
| 1 | HIGH | 1/2 to 1 1/2 | 1 | |
| 2 | HIGH | 1 to 2 | 1 | |
| 4 | HIGH | 1 1/2 to 3 | 1 | |
| Ham, fully cooked Canned 3 lbs (1.3kg) *Approx. temp. after stand 120°F to 130°F (50°C to 55°C) | 5 (50) | 6 to 12 | 10 | Shield edge of ham with strip of foil. Place on roasting rack. Cover with waxed paper. Turn over halfway through cooking. |
| Ham, Slice 1-inch (2.5cm) Thick per 1 lb (450g) | HIGH | 6 to 13 | 5 | Place in a shallow dish. Cover with waxed paper. Turn over halfway through cooking. |
| Pork Roast per 1-lb (450g) * Approx. temp. after stand 170°F to 175°F (77°C to 79°C) | 5 (50) | 12 to 17 | 10 to 15 | Cook in a covered casserole or cover with plastic wrap. |

MEATS, POULTRY AND FISH(Cont'd)

| FOOD | POWER (%) | APPROX. COOKING TIME (in minutes) | STAND TIME (in minutes) | SPECIAL NOTES |
|---|-----------|-----------------------------------|-------------------------|--|
| Sausage Links, frozen (precooked brown and serve) | | | | |
| 2 | HIGH | 1 to 2 1/2 | 1 | Pierce before cooking. |
| 4 | HIGH | 2 to 4 | 1 | |
| Sausage Links, fresh 1 to 2 oz (30-60g) each | | | | |
| 2 | HIGH | 3 to 5 | 1 | Pierce before cooking. Cover with plastic wrap. |
| 4 | HIGH | 4 to 7 | 1 | Turn over once. |
| Lamb | | | | |
| Chops, Shoulder 1/2-inch (1cm) thick | | | | |
| 1 | HIGH | 2 to 4 | 2 | Arrange in a shallow dish. Cover loosely with waxed paper to prevent spattering. |
| 2 | HIGH | 4 to 6 | 5 | |
| Poultry per 1 lb (450g) | HIGH | 8 to 11 | 10 | Place on a roasting rack in a dish. Cover with plastic wrap or lid. |
| Chickens 4 lbs (up to 1.8kg) | HIGH | 13 to 20 | 10 Tented with foil | |
| Chicken Pieces 2 lbs (up to 900g) | HIGH | 6 to 8 | 5 | Arrange skin-side up in shallow baking dish, meatier portions toward edge of dish. Cover with plastic wrap or lid. |
| Fish or Seafood | | | | |
| Fish Fillets 3/4 lb (350g) | HIGH | 4 to 5 | 3 | Arrange in a single layer in dish. Cover with waxed paper. Rearrange or stir shrimp or scallops halfway through cooking. |
| Fish Steaks 2 [6 oz (170g)each] | 5 (50) | 5 to 8 | 5 | |
| Scallops 1 lb (450g) | 7 (70) | 5 to 8 | 3 | |
| Shrimp, medium size 1 lb (450g) (shelled and cleaned) | 7 (70) | 4 to 6 | 3 | |
| Whole fish 1 1/2 to 1 3/4 lbs | HIGH | 5 to 7 | 5 | |

BAKED GOODS AND DESSERTS

CONVERTING RECIPES

When adapting "quick bread" recipes, you will find it necessary to reduce the amount of leavening (baking powder or soda) by about one-quarter the normal amount. A bitter aftertaste is apparent if too much leavening is used in biscuits or muffins. Since food rises higher in the microwave oven, you will not see a loss in volume from the reduction of soda or baking powder. If a recipe contains buttermilk or sour cream, do not change the amount of soda, since it serves to counteract the sour taste as well as leavening agent.

When using a mix where leavening cannot be reduced, allow the dough to stand about 10 minutes before cooking in order for some of the gas to be lost. Otherwise observe the following guidelines.

- Breads and rolls should be reheated only until they are warm to the touch. Overheating or overcooking makes bread tough and rubbery.

Cooking / Reheating Guide

| ITEM | POWER (%) | APPROX. COOKING/ REHEATING TIME | SPECIAL NOTES |
|--|----------------------------------|--|--|
| Hamburger buns, hot dog rolls frozen: 1 lb (450g) Room temp: | 1 5 (50) 2 5 (50) 4 5 (50) | 2 - 3 min. 15 - 20 sec. 20 - 25 sec. 20 - 30 sec. | Place on paper plate or wrap in paper towel. |
| Doughnuts, sweet rolls, muffins | 1 5 (50) 2 5 (50) 4 5 (50) | 15 - 20 sec. 25 - 30 sec. 30 - 45 sec. | Place on paper plate or towel. Add 15 seconds if frozen. |
| Whole coffee cake, Frozen: 10-13 oz (280-370g) Room temp.: 10-13 oz (280-370g) | 5 (50) 5 (50) | 1 1/2 - 2 min. 1 1/2 - 2 min. | Place on paper plate or towel. |
| French bread, Frozen: 1 lb (450g) Room temp.: 1 lb (450g) | 5 (50) 5 (50) | 2 - 2 1/2 min. 30 - 40 sec. | Place on paper plate or towel. |

| ITEM | AMOUNT OF BATTER | D I S H | COOKING POWER AND TIME (in minutes) | | STAND TIME | SPECIAL NOTES |
|---|---------------------|-------------------------------------|---|---------------------|------------------------|--|
| | | | FIRST STAGE | SECOND STAGE | | |
| Butter Cake: Single layer or half of prepared mix | 2 1/4 cups (550mL) | 8 to 9-inch (20 to 23cm) round dish | 5 (50) 7 to 9 min. | HIGH 3 to 4 | 10 min. | Place on inverted pie plate. |
| Brownies | 2 cups (500mL) | 8 to 9-inch (20 to 23cm) round dish | 5 (50) 10 to 13 min. | | Cool with waxed paper. | Cover with waxed paper. Place on inverted pie plate. |
| Bar Cookies | 1 1/2 cups (400mL) | 8 to 9-inch (20 to 23cm) round dish | 5 (50) 7 to 9 min. | HIGH 2 to 3 min. | Cool completely. | Cover with waxed paper, during 1st stage. |
| Muffins large size | 1/4 cup (50mL) each | 1 2 6 | 7 (70) 35 to 60 sec. 1 to 1 1/2 min. 4 to 5 min. | | | |

AUTO DEFROST CHART

| ITEM | SPECIAL NOTES |
|---|---|
| DEFROST 1 -MEAT | |
| BEEF | |
| Ground beef | Remove thawed portions at beeps. Turn over. Return remainder to oven. |
| Round steak, Flank steak, Tenderloin steak, Chuck roast, Rib roast, rolled Rump roast, Sirloin tip roast | Use a microwave-safe roasting rack. Turn over at pause. Cover warm areas with aluminum foil. |
| Stewing meat | Remove thawed portions at beeps. Separate remainder and return it to oven. |
| LAMB | |
| Cubed for stewing | Remove thawed portions at beeps. Separate remainder and return it to oven. |
| Chops | Use a microwave-safe roasting rack. Separate and rearrange at beeps. |
| Roast | Use a microwave-safe roasting rack. Turn over at beeps. Cover warm areas with aluminum foil. |
| PORK | |
| Chops, 1/2inch (1cm) thick | Use a microwave-safe roasting rack. Separate and rearrange at beepse. |
| Spareribs, Country-style ribs, roast | Use a microwave-safe roasting rack. Turn over at beeps. Cover warm areas with aluminum foil. |
| Sausage, bulk | Use a microwave-safe dish. Remove thawed portions at beeps. Turn over. Remainder to oven. |
| Return | |
| Sausage, links | Separate and rearrange at beeps. |
| WEAL | |
| Chops, 1/2inch (1cm) thick | Use a microwave-safe roasting rack. Separate and rearrange at beeps. |
| Roast | Use a microwave-safe roasting rack. Turn over at beeps. Cover warm areas with aluminum foil. |
| VARIETY MEAT | |
| Liver, sliced | Use a microwave-safe dish. Separate pieces and rearrange at beeps. |
| Tongue, whole | Use a microwave-safe roasting rack. Turn over at beeps. Cover warm areas with aluminum foil. |
| | |
| DEFROST P-POULTRY | |
| CHICKEN | |
| Whole | Place chicken breast-side-up in microwave-safe roasting rack. Turn over at beeps. Cover warm areas with aluminum foil. Giblets may still be frozen but chicken will be thawed. Rinse in cold water. |
| Pieces | Use a microwave-safe roasting rack. Separate pieces and rearrange at beeps. Turn over. Cover warm areas with aluminum foil. |
| CORNISH HENS | |
| Whole | Place on a microwave-safe roast rack. Finish defrosting by rinsing in cold water. |
| TURKEY | |
| Breast (under 6 lbs.) | Place on a microwave-safe roast rack. Finish defrosting by rinsing in cold water. |

AUTO DEFROST CHART(Cont'd)

| I T E M | SPECIAL NOTES |
|---|--|
| DEFROST 3-STEAKS AND CHOPS | |
| FISH | |
| Filletts | Place in a microwave-safe baking dish. Carefully separate filletts under cold water. |
| Whole Steaks | Place in a microwave-safe baking dish. Turn over at beeps. Run cold water over to finish defrostina. |
| Whole | Place in a microwave-safe baking dish. Cover head and tail with foil; Do not let foil touch sides of microwave. Turn over at beeps. Finish defrosting by rinsing in cold water. |
| Crabmeat, Lobster tails, Shrimp, Scallop | Place in a microwave-safe baking dish. Break apart halfway through defrost time or at beeps. |

CONVERSION TABLE

NOTES: 1 Kg = 1000 grams

Only 1 digit can be entered after a decimal point.

Round fiaures off to the lower number to avoid overdefrostina. Ex. 1.28lbs. use 1.2.

| lbs | lbs/oz. | grams | kg. | lbs | lbs/oz. | grams | kg. |
|------------|----------|-------|------------|------------|----------|-------|------------|
| 0.3 | 4oz | 100 | 0.1 | 5.7 | 5lb 12oz | 2600 | 2.6 |
| 0.5 | 7oz | 200 | 0.2 | 5.9 | 5lb 15oz | 2700 | 2.7 |
| 0.7 | 10oz | 300 | 0.3 | | 6lb 3oz | 2800 | 2.8 |
| 0.9 | 14oz | 400 | 0.4 | | 6lb 6oz | 2900 | 2.9 |
| 1.1 | 1lb 2oz | 500 | 0.5 | | 6lb 10oz | 3000 | 3.0 |
| 1.3 | 1lb 5oz | 600 | 0.6 | | 6lb 13oz | 3100 | 3.1 |
| 1.6 | 1lb 9oz | 700 | 0.7 | | 7lb | 3200 | 3.2 |
| 1.8 | 1lb 12oz | 800 | 0.8 | | 7lb 4oz | 3300 | 3.3 |
| 2.0 | 2lb | 900 | 0.9 | | 7lb 8oz | 3400 | 3.4 |
| 2.2 | 2lb 4oz | 1000 | 1.0 | | 7lb 11oz | 3500 | 3.5 |
| 2.4 | 2lb 7oz | 1100 | 1.1 | | 7lb 15oz | 3600 | 3.6 |
| 2.7 | 2lb 11oz | 1200 | 1.2 | | 8lb 3oz | 3700 | 3.7 |
| 2.9 | 2lb 14oz | 1300 | 1.3 | | 8lb 6oz | 3800 | 3.8 |
| 3.1 | 3lb 2oz | 1400 | 1.4 | | 8lb 10oz | 3900 | 3.9 |
| 3.3 | 3lb 5oz | 1500 | 1.5 | | 8lb 13oz | 4000 | 4.0 |
| 3.5 | 3lb 9oz | 1600 | 1.6 | | | | |
| 3.8 | 3lb 12oz | 1700 | 1.7 | | | | |
| 4.0 | 4lb | 1800 | 1.8 | | | | |
| 4.2 | 4lb 3oz | 1900 | 1.9 | | | | |
| 4.4 | 4lb 7oz | 2000 | 2.0 | | | | |
| 4.6 | 4lb 10oz | 2100 | 2.1 | | | | |
| 4.9 | 4lb 14oz | 2200 | 2.2 | | | | |
| 5.1 | 5lb 1oz | 2300 | 2.3 | | | | |
| 5.3 | 5lb 5oz | 2400 | 2.4 | | | | |
| 5.5 | 5lb 8oz | 2500 | 2.5 | | | | |

PRECAUTIONS

1. Do not attempt to tamper with, or make any adjustments or repairs to door, control panel, safety interlock switches or any other part of the oven. Repairs should be done by qualified service personnel only.
2. Be certain to place the front surface of the door three inches or more away from the countertop edge to avoid accidental tipping of the appliance in normal usage.
3. For the most accurate programming of the electronic units, touch the center of each pad securely. Do not touch several pads at one time or touch in between pads. A beep sound should be heard with each touch when pad is touched correctly.
4. Do not hit or strike the control with objects such as silverware, utensils, etc. Breakage may occur.
5. Be careful when taking the cooking utensils out of the oven. Some dishes absorb heat from the cooked food and may be hot.
6. Do not rinse cooking utensils by immediately placing them into water just after cooking. This may cause breakage. Allow the turntable to cool down.
7. Do not operate the oven empty. Either food or water should always be in the oven during operation to absorb microwave energy.
8. Do not heat unopened food containers in the oven. Pressure build-up can cause the container to burst, resulting in injury.
9. Do not use your microwave oven to dry newspapers or clothes. They can catch fire.
10. Only use thermometers approved for microwave oven cooking.
11. Be certain the turntable is in place when you operate the oven.
12. Pierce the skin of potatoes, whole squash, apples or any fruit or vegetable which has a skin covering, before cooking.
13. Never use your microwave oven to cook eggs in the shell. Pressure can build up inside the shell causing it to burst.
14. Do not pop popcorn, except in a microwave-approved popcorn popper or commercial package designed especially for microwave ovens.
Never try to pop popcorn in a paper bag not designed for microwave oven use. Overcooking may result in smoke and fire. Do not repop unpopped kernels. Do not reuse popcorn bags.

QUESTIONS AND ANSWERS

Q. What's wrong when the oven light will not glow?

A. There may be several reasons why the oven light will not glow.

- Door is not closed. ■ Light bulb is burned out ■ START has not been touched
-

Q. Does microwave energy pass through the viewing screen in the door?

A. No. The holes, or ports, are made to allow light to pass; they do not let microwave energy through.

Q. Why does the beep tone sound when a pad on the Control Panel is touched?

A. The beep tone sounds to assure that the setting is being properly entered.

Q. Will the microwave oven be damaged if it operates empty?

A. Yes. Never run it empty or without the glass tray.

Q. Why do eggs sometimes pop?

A. When baking, frying, or poaching eggs, the yolk may pop due to steam build up inside the yolk membrane. To prevent this, simply pierce the yolk before cooking. Never microwave eggs in the shell.

Q. Why is standing time recommended after microwave cooking is over?

A. After microwave cooking is finished, food keep on cooking during standing time. This standing time finishes cooking evenly throughout the food. The amount of standing time depends on the density of the food.

Q. Is it possible to pop popcorn in a microwave oven?

A. Yes, if using one of the two methods described below:

- (1) Popcorn-popping devices designed specifically for microwave cooking.
- (2) Prepackaged commercial microwave popcorn that contains specific times and power outputs needed for an acceptable final product.

FOLLOW EXACT DIRECTIONS GIVEN BY EACH MANUFACTURER FOR THEIR POPCORN PRODUCT. DO NOT LEAVE THE OVEN UNATTENDED WHILE THE CORN IS BEING POPPED. IF CORN FAILS TO POP AFTER THE SUGGESTED TIMES, DISCONTINUE COOKING. OVERCOOKING COULD RESULT IN AN OVEN FIRE.

CAUTION: NEVER USE A BROWN PAPER BAG FOR POPPING CORN OR ATTEMPT TO POP LEFTOVER KERNELS.

Q. Why doesn't my oven always cook as fast as the cooking guide says it should?

A. Check your cooking guide again to make sure you've followed the directions correctly, and to see what might cause variations in cooking time. Cooking guide times and heat settings are suggestions chosen to help prevent overcooking, the most common problem in getting used to a microwave oven. Variations in the size, shape, weight and dimensions of the food could require longer cooking time. Use your own judgement along with the cooking guide suggestions to test for doneness, just as you would do with conventional cooking.

Limited Warranty

For Dometic Microwave Models CDMW10MW
CDMW10MB

THE SELLER NAMED BELOW MAKES THE FOLLOWING WARRANTY
WITH RESPECT TO THIS DOMETIC MICROWAVE OVEN.

1. This Warranty is made only to the first Purchaser (hereinafter called the "Original Purchaser") who acquires this product for his own use.
2. This Warranty will be in effect for three years from the date of purchase by the Original Purchaser. It is suggested that the Original Purchaser retain a copy of the dated bill of sales as evidence of the date of purchase.
3. This Warranty covers only specified parts which shall be free from defects in material and workmanship under normal use. This Warranty does not cover conditions unrelated to the material and workmanship of the product. Such unrelated conditions include, but are not limited to (a) faulty installation and any damage resulting from such; (b) the need for normal maintenance and any damage resulting from the failure to provide such maintenance; (c) failure to follow Seller's instructions for use of the product, and (d) any accident to, or misuse of any part of this product and any alteration by anyone other than Seller or the authorized representative.
4. In order to obtain the benefits of this Warranty, you should return the product which you find defective to your dealer during the period that this Warranty is in effect. All charges incurred in delivery of the microwave to Seller must be paid by the Original Purchaser. A copy of the dated bill of sale must accompany the returned microwave oven.
5. Any item returned in the manner described in paragraph 4 will be examined by your dealer. If it is found that the microwave is defective in material and workmanship, the Seller will replace the appliance.
6. The Seller does not authorize any person or company to create an warranty obligation or liability on their behalf.
7. IN NO EVENT SHALL SELLER BE LIABLE FOR INCIDENTAL OR CONSEQUENTIAL DAMAGES, SOME STATES DO NOT ALLOW THE EXCLUSION OR IMITATION OF INCIDENTAL OR CONSQUENTIAL DAMAGES SO THE ABOVE LIMITATION MAY NOT APPLY TO YOU.
8. ANY IMPLIED WARRANTY, INCLUDING THE IMPLIED WARRANTY OF MERCHANTABILITY AND FITNESS FOR ANY PURPOSE, IS LIMITED TO THE DURATION OF THIS LIMITED WARRANTY, SOME STATES DO NOT ALLOW LIMITATIONS ON HOW LONG AN IMPLIED WARRANTY LASTS, SO THE ABOVE LIMITATION MAY NOT APLLPY TO YOU.
9. THIS WARRANTY GIVES YOU SPECIFIC LEGAL RIGHTS, AND YOU MAY ALSO HAVE OTHER RIGHTS WHICH VARY FROM STATE TO STATE.
10. All appliances (except those specifically built for commercial use) are warranted only when installed in vehicles built to the R.V.I.A and CSA Standards.

Seller in USA

The Dometic Corporation
The Warranty Department
509 South Poplar Street
LaGrange, Indiana 46761

Seller in CANADA

The Dometic Corporation
The Warranty Department
866 Langs Drive
Cambridge, Ontraio
Canada N3H2N7