

DUO-THERM

GAS SEALED FORCED AIR FURNACE Installation & Operating Instructions

The 65000 Series DUO-THERM sealed combustion system forced air furnace is certified by the American Gas Association for installation in a mobile home or travel trailer. These furnaces are for use with L.P. gases and must be installed in accordance with these instructions for proper performance. Before starting the installation, consult applicable state and local codes.

Minimum Clearances from Combustible Material

Side	0"
Top	0"
Bottom	0"
Front	As required for accessibility and return air

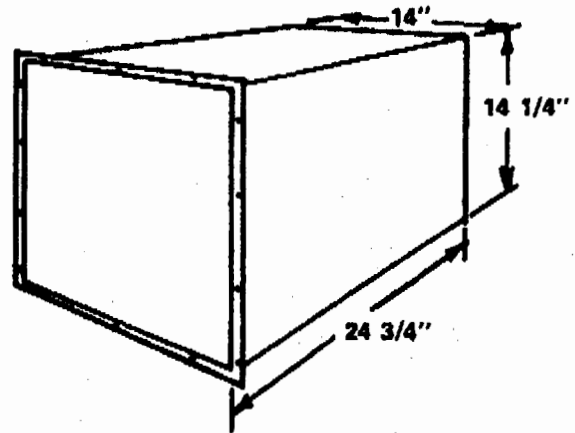

DIMENSIONS

Length	24 3/4"
Height	14 1/4"
Width	14"

MODEL NUMBER		65017	65020	65025	65028
A.G.A. RATING BTU/Hr.	SEA INPUT	16,500	19,000	25,000	28,000
	LEVEL Bonnet Capacity	13,200	15,200	20,000	22,400
For elevation above 2,000 feet, the appliance shall be derated 4 percent for each 1,000 feet of elevation above sea level.					
Gas Connection		3/8" N.P.T.	3/8" N.P.T.	3/8" N.P.T.	3/8" N.P.T.
Electrical	Suffix -1; -3; -5	115 VAC & 12 VDC			
	Suffix -2; -4; -6	12 VDC ONLY			
Pilot Gas Ignitor	Suffix -3; -4; -5; -6	* NOT AVAILABLE ON 65017			

The installation is to be adjusted to obtain a temperature rise within the range specified on the furnace rating plate.

When used in connection with a cooling unit, the furnace shall be installed parallel with or on the upstream side of the cooling unit to avoid condensation in the heating element.

READ THESE INSTRUCTIONS AND KEEP FOR FUTURE REFERENCE.

Installation Instructions

INSTALLATION FOR SIDE DUCT DISCHARGE

The furnace can be installed at 0 in. clearance to the sides when employing special duct connector No. 9-2654 in any of several configurations.

The side duct configurations are:

- A. Front right and left
- B. Rear right and left
- C. Front right and rear left
- D. Front left and rear right

The furnace casing has two knockouts on each side, each with four pre-drilled holes for mounting side duct connectors.

INSTALLATION ACCESSORIES

The only parts required for the side duct discharge installation are two part number 9-2654, SIDE DUCT CONNECTORS, with screws, See Figure 1.

INSTALLATION

1. Select a location for the furnace on an outside wall as near the center of the coach as possible. Check for obstructions.
2. Cut outside wall opening 14-1/8" wide by 14-3/8" high. See Figure 2.
3. Remove desired 4" by 4" knockouts from side of furnace casing and cut out insulation around holes.
4. Slide furnace into opening. Before sliding all the way in, apply mastic or permagum sealant to back of vent pan. Secure furnace with screws to the outer wall. Attach exterior vent panel.
5. Attach side duct connectors to furnace casing with screws that are provided. Slide ducts over connectors and seal with duct tape. See Figure 3.

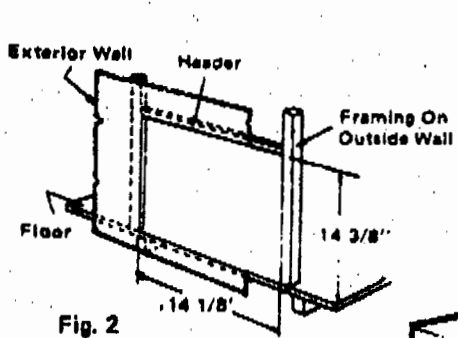

Fig. 1



Secure Furnace to Outer Wall with Screws

Fig. 2

Fig. 3

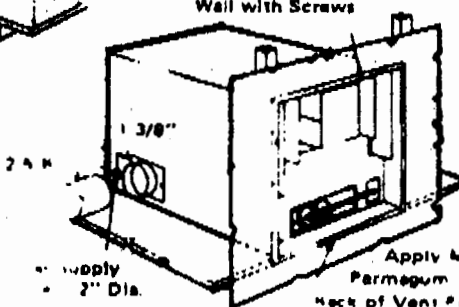

INSTALLATION FOR BOTTOM DUCT DISCHARGE

The furnace can be installed at 0 in. clearance to the bottom when employing special duct connector Part No. 9-2656 in any of the following configurations:

Bottom duct configurations are:

- A. Bottom Front
- B. Bottom Rear

The furnace casing has four knockouts in the bottom pane. For option A above, remove two knockouts in bottom front. For option B above, remove two knockouts in bottom rear.

INSTALLATION ACCESSORIES

The only part required for the bottom duct discharge installation is Part No. 9-2656, BOTTOM DUCT CONNECTOR. See Figure 4.

Part No. 9-2655 FLOOR TEMPLATE, furnished upon request

INSTALLATION

1. Select a location on the outside wall as near the center of the coach as possible. Check for obstructions.
2. Cut outside wall opening 14 1/8" wide by 14 3/8" high. See Figure 2.
3. Remove desired 2 7/8" by 5" knockouts from bottom of furnace casing and cut out insulation around holes.
4. Lay floor template and mark location of desired opening. Remove floor template and cut floor through at this location.
5. Place the bottom duct connector in the duct opening and bend the tabs over to secure. Seal the connector with duct tape. See Figure 5.
6. Slide furnace into wall opening carefully so as not to damage gasket. Before sliding all the way in, apply mastic or permagum sealant to back of vent pan. Secure furnace with screws to the outer wall. Attach exterior vent panel.

Part No. 9-2656
Bottom Duct Connector

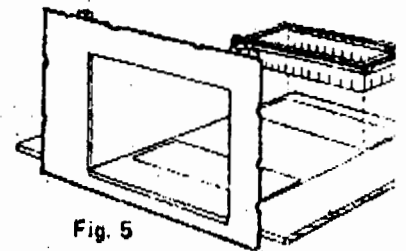

Fig. 5

Part No. 9-2655
Floor Template

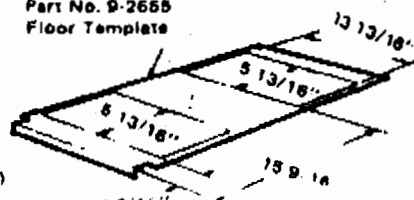

Fig. 4

ELECTRICAL WIRING

1. Remove cover from electrical enclosure
2. Bring battery leads through casing opening on left side and connect to terminals marked "12VDC+". Observe polarity of leads when making connections.
3. Bring thermostat lead through same opening and connect to terminals marked "THERM".

Recommended wire size: 12VDC - No. 12 or No. 14 AWG
Thermostat - No. 18 AWG Solid or stranded

4. Bring 115 VAC (60 cycle) supply leads through 7/8" diameter hole in junction box. Connect leads in junction box with approved splicing device.

GAS PIPING

1. Route gas supply line through opening on right side of furnace or through bottom of casing. See Figure C
2. Paint male threads of all pipe joints with a compound resistant to the action of L.P. gases to prevent gas leak. Connect gas supply line to the gas control. Turn on gas and check for leaks at all joints. USE A SOAP AND WATER SOLUTION. DO NOT USE FLAME.

NOTE: IF LOCAL CODE REQUIRES AN EXTERNAL SHUT OFF VALVE, IT MUST BE LOCATED OUTSIDE THE FURNACE CASING.

WIRING DIAGRAM

65000-1 SERIES
115 VAC AND 12 VDC

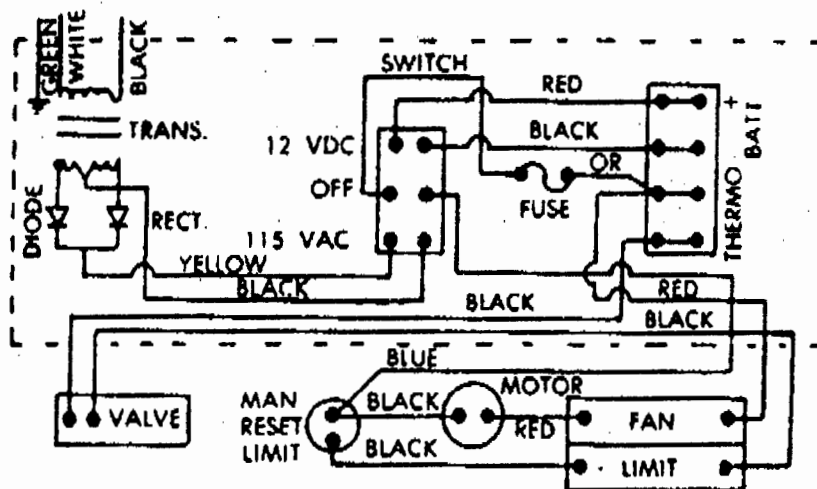

65000-2 SERIES
12 VDC ONLY

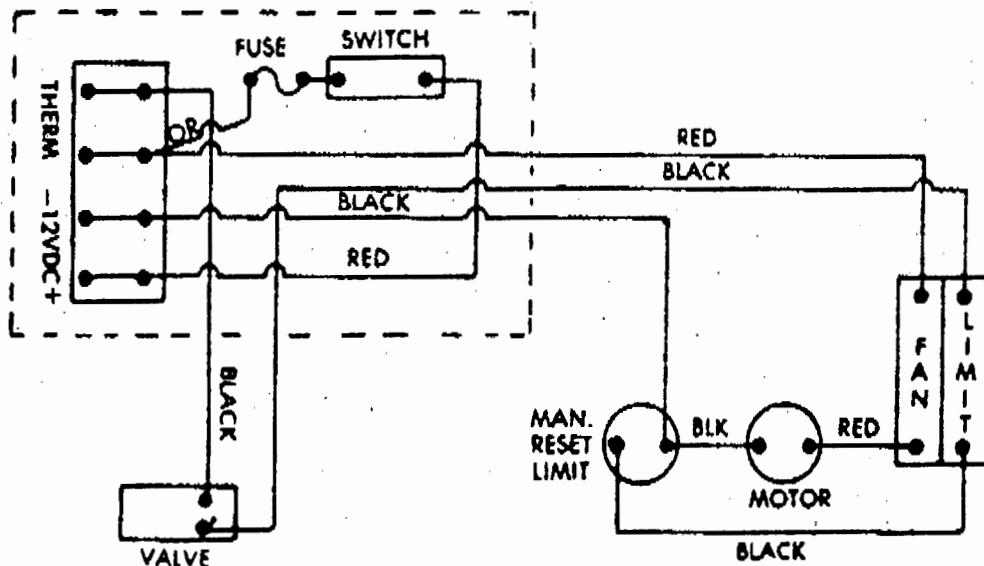

Operating Instructions

NO. 65000 SERIES SEALED COMBUSTION SYSTEM FORCED-AIR FURNACE

NOTE:

If furnace is equipped with a converter package, set voltage selector switch to desired voltage. To conserve battery power use 115 VAC whenever available.

LIGHTING AND RELIGHTING INSTRUCTIONS

For Models without Spark Igniter
(Suffix -5 & -6)

1. Press gas cock dial in and turn to "Off".
2. Turn thermostat to lowest setting and wait five minutes.
3. Turn gas cock dial to "Pilot".
4. Press gas cock dial in and light pilot. Hold in until pilot remains lighted. (30 - 60 seconds).
5. Turn gas cock dial to "ON".
6. Set thermostat to desired temperature.

For complete shut off, press gas cock dial in and turn to "Off". Turn thermostat to lowest setting.

For Models with Spark Igniter
(Suffix -3, -4, -5 & -6)

1. Press cock dial in and turn to "Off".
2. Turn thermostat to lowest setting and wait five minutes.
3. Turn gas cock dial to "Pilot".
4. Press gas cock dial in and light pilot by depressing spark igniter. Several strokes of the igniter may be required before pilot gas will ignite. Hold gas cock dial in until pilot remains lighted.
5. Turn gas cock dial to "On".
6. Set thermostat to desired temperature.

For complete shut off, press gas cock dial in and turn to "Off". Turn thermostat to lowest setting.

PILOT ADJUSTMENT

Remove pilot adjusting cap on gas control. Adjust screw so flame completely envelopes the end of the thermocouple.

MAINTENANCE

The control compartment must be cleaned periodically to remove duct and lint.

IMPORTANT

Obstruction in the pilot system can cause pilot problems. Some of these obstructions could be as follows:

- A. Spider web in pilot burner.
- B. Dust or lint in the line.
- C. Dirt in the line.
- D. Water in the line.

Any of the above obstructions will require cleaning and/or removal. Since the above items (A-D) are not directly attributed to the manufacture of the furnace, nor to defective parts, IT IS NOT A WARRANTY PROBLEM.

OPERATION OF THE FURNACE

When the thermostat closes, the circuit to the electrically operated gas valve is completed. Gas is passed to the main burners and ignited by the pilot. As the heat rises in the chamber the automatic fan switch closes and the circulating air blower operates. When the thermostat is satisfied the circuit to the electrically operated gas valve is opened. This shuts off the gas flow to the main burners. When the temperature of the air inside the furnace is approximately 105°F the fan switch opens and stops blower operation.

LIMIT CONTROLS

This furnace is equipped with an automatic reset limit control and a manual reset limit control. The automatic control is incorporated into the fan switch and is located on the upper right side of the blower panel. The manual reset limit control is located on the right side of the blower housing behind cover. The limit switches will open when the heat exceeds the limit, caused by blocked registers, defective fan switch, defective blower motor, etc. and will not close until the abnormal conditions are corrected. The manual switch must be reset manually. Press the red button in until a click is heard.

NOTE: If it is necessary to reset the manual switch any consecutive number of times, the cause of its tripping should be determined immediately.

FAN SWITCH

The fan switch is located on the upper right side of the blower panel. The control is calibrated at the fan off temperature which can be adjusted through a range of approximately 35° F.

This furnace should be adjusted by the installer to insure a temperature rise indicated on the rating plate.

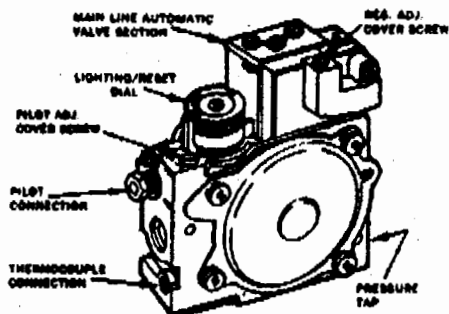

LIGHTING PROCEDURE



1. Turn to PILOT. Press dial in and light pilot. Hold for 60 seconds and release.



2. Turn dial counterclockwise to ON. Use this position for main burner-on control.



3. Turn dial clockwise to PILOT, press dial in and turn to OFF. Use this position when complete shutdown is necessary, (Use PILOT position for temporary or seasonal shutdowns).