

# hydro flame corp.

1874 SOUTH PIONEER ROAD • SALT LAKE CITY, UTAH 84104

*Everest Star*

Installation Instructions  
For Models  
FA-7920, FA-7916, FA-7912  
and HF-8012

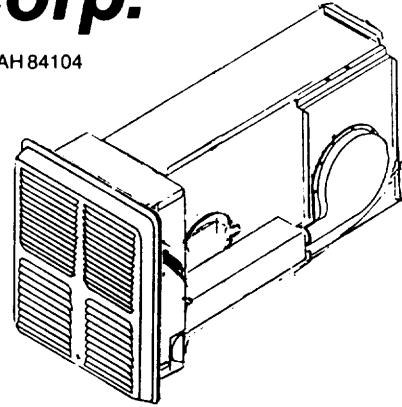

Direct Vent Central and Fan-Type Direct Vent Wall Furnaces, for Installation in Recreational Vehicle or Manufactured (Mobile) Home.



TESTED TO U.L. 307(b)



CERTIFIED BY C.G.A.

These furnaces are for use with propane gas only and must be installed only by QUALIFIED personnel in accordance with these instructions. The installation must also conform with the following codes where they apply.

## ALL LOCAL CODES

1. National Fuel Gas Code ANSI Z 223.1 1984.
2. American National Standard for Recreational Vehicles, ANSI A 119.2 1982 and A 119.5.
3. CSA Z 240.4, 1 and 2 and Z 240.6.2.
4. Can 1-B 149 Installation Code.
5. The Manufactured Home Construction and Safety Standard (Title 24, CFR part 3280).
6. This furnace conforms to Part 280.707(a)(2) of Hud Mobile Home Construction and Safety Standard.

THIS FURNACE WAS TESTED AND INSPECTED BEFORE IT LEFT THE FACTORY. IF ANY PARTS ARE FOUND TO BE DAMAGED, DO NOT INSTALL THE FURNACE. IMMEDIATELY CONTACT THE TRANSPORTATION COMPANY AND FILE A CLAIM.

**WARNING: IMPROPER INSTALLATION, ADJUSTMENT ALTERATION, SERVICE OR MAINTENANCE CAN CAUSE INJURY, PROPERTY DAMAGE OR DEATH. THIS FURNACE IS NOT DESIGNED FOR USE WITH AIR FILTERS NOR ARE THEY TO BE USED IN CONJUNCTION WITH COOLING UNITS. READ ALL INSTRUCTIONS BEFORE STARTING.**

These furnaces are design certified for propane gas only, (**DO NOT CONVERT TO NATURAL GAS**) at the following gas inlet pressure 11.0" W.C. maximum. (W.C. = Water Column)

**WARNING: THESE FURNACES MUST BE INSTALLED AND VENTED SO THAT THE NEGATIVE PRESSURE CREATED BY THE CIRCULATING AIR BLOWER CANNOT EFFECT THE COMBUSTION AIR INTAKE OR VENTING OF ANY OTHER APPLIANCE.**

Model No.	Input BTU/HR	Output BTU/HR	Type Gas	Electrical Rating	Amps	Watts
FA-7920 (D or P)	19,500	15,700	Propane	12 VDC	2.9	34.8
FA-7916 (D or P)	16,000	12,900	Propane	12 VDC	2.9	34.8
FA-7912 (D or P)	12,000	10,000	Propane	12 VDC	2.9	34.8
HF-8012 (D or P)	12,000	10,000	Propane	12 VDC	1.6	19.2

### LETTERS AFTER THE MODEL NUMBER STAND FOR:

D = Direct Spark Ignition

P = Piezo Spark Ignition

### FURNACE DIMENSIONS

	Casing	Door	Vent Cap
Width	8"	9 <sup>7</sup> / <sub>8</sub> "	5 <sup>7</sup> / <sub>8</sub> "
Height	11"	11 <sup>1</sup> / <sub>2</sub> "	3 <sup>3</sup> / <sub>8</sub> "
Length	20 5/16"	—	—
Depth	—	1 <sup>1</sup> / <sub>4</sub> "	5/8"

Due to High Temperatures, the appliance should be located out of traffic and away from furniture and draperies. Adults and Children should be alerted to the hazards of high surface temperatures and should stay away to avoid burns or clothing ignition. Young children should be carefully supervised when they are in the same room as the appliance. Clothing or other flammable materials should not be placed on or near the appliance. Any safety screen or guard removed for servicing an appliance must be replaced prior to operating the appliance. Installation and repair should be done by a qualified service person. The appliance should be inspected before each use and at least annually by a professional service person. Note frequent cleaning may be required due to excessive lint from carpeting, bedding material, etc. It is imperative that control compartments, burners, and circulating air passageways of the appliance be kept clean.

### MINIMUM CLEARANCE TO COMBUSTIBLES.

TOP AND SIDES = 1/4" (0" TO SPACERS)

AIR TUBE = 0"

REAR = 0"

FRONT AS REQUIRED FOR SERVICE.

DUCTS WITHIN 3'-0" OF FURNACE 1/4" EXCEPT THAT U.L.

LISTED WIRE BOUND VINYL AIR DUCTS MAY HAVE 0" CLEARANCE.

### RETURN AIR

1. Return air is supplied through front grill panel. All that is needed is to maintain the required clearances as called for.
2. If sufficient area is not obtainable an additional air grill can be used allowing for a minimum of 35 square inches of open area to the furnace.

### INSTALLATION

This furnace must be installed in accordance with these instructions and all National or Local Codes and C.S.A. Standards.

1. Select a location for installing the furnace through an outside wall. It is recommended that it be located as far as possible from any outside projection such as a tilt out room.
2. Remove from furnace the combustion air box extension (B) and the exhaust tube extension (C) which will be installed from the outside of the coach.

3. Provide an 11¼" high x 8¾" wide opening in the cabinet and 2 7/16" high x 4 15/16" wide opening in the outside wall. See figure 1.
4. On side discharge models remove the left knockout plate. See figure 3.
  - A. On front discharge type models remove the front discharge cover plate. See figure 5.
  - B. On optional front/side models remove or install the duct cover plate or front discharge cover plate.
  - C. To install duct adapters for side discharge models, insert back flange over casing and insert tab into square notch then twist adapter 180 degrees.
5. Install furnace into cabinet opening and secure with two screws through holes that are provided in control box flanges. See figure 4.
  - A. Slide 4" ducting material over duct adapters and secure and seal for ducted models.
6. To determine the vent lengths required, determine the length from the back of the furnace casing to the outside of vehicle side wall, this will give you "A" dimension. See figure 2 for correct vent kit.
  - A. To install combustion air box apply mastic or sealant to back of flanges on box. Slide through outside wall cut out and into furnace air channel. (DO NOT FORCE OR BEND PARTS OUT OF SHAPE.)
  - B. Apply mastic or sealant to the top and sides of the outer edge of the vent cap, (DO NOT PLUG HOLES). Slide assembly over furnace exhaust tube, push into wall and secure with two screws. Note bottom flange is not sealed to allow water drainage.
7. Install self trim door by sliding door flange over control box top flange and pushing in on bottom of door. NOTE: To assure sufficient return air to the circulating blower maintain specified clearances.

## ELECTRICAL

1. Remove junction box cover from furnace by removing screw located on the right side. See figure 5.
2. Route wiring to right side of furnace using a minimum of 18 GA. wire, except for thermostat wires.
3. Connect furnace wiring to field wiring as shown.

### FIELD LEADS

12 VDC (+) and thermostat  
 12 VDC (-)  
 Thermostat

### FURNACE LEADS

-to- Red (+) 12 VDC and thermostat  
 -to- Black (-) 12 VDC  
 -to- White thermostat

4. Replace junction box cover.

### NOTE:

1. OBSERVE POLARITY OF LEADS WHEN CONNECTING.
2. Ground the furnace in accordance with national electrical ANSI/NPFA No. 70 1984 and all local codes, Canadian Electrical Code C-22.1.

## **GAS PIPING**

For gas piping and pipe sizing, refer to the Federal Mobile Home Construction and Safety Standard, part 280, N.F.P.A. 54 or ANS/N.F.P.A. NO. 501C-1977 and all state and local codes.

Gas Line hook-up is made through the left side of the furnace casing. Actual hook-up is accomplished inside the furnace casing immediately ahead of the Gas Control Valve.

A 3/8" flared fitting connection is provided at the control valve inlet for gas supply connection to the furnace. The gas supply line of the furnace must be of adequate size to provide 11" water column gas pressure. This pressure must be maintained under maximum flow conditions with all gas appliances in operation. Tubing may be type "K" for propane gas (Bottled Gas), however be sure to check with ANS, CGA and CSA Standards for any other requirements concerning gas piping.

This furnace and its individual shut-off valve must be disconnected from the gas supply piping system during any pressure testing of that system at test pressure in excess of 1/2 psig. (3.45 KPA).

This furnace must be isolated from the gas supply piping system by closing the manual shut-off valve during any pressure testing of the gas supply piping system at test pressures equal to or less than 1/2 psig. (3.45 KPA).

A 1/8" N.P.T. plugged tapping accessible for test gage connection is recommended, installed immediately up stream of the gas supply connection to the furnace.

### **IMPORTANT:**

All pipe joints must be sealed with a sealing compound resistant to the effects of LP or Natural Gas. These joints must then be leak checked.

**NEVER USE A FLAME TO CHECK FOR LEAKS.**

**CAUTION: DO NOT TWIST VALVE DURING PIPING.**

### **NOTE:**

Standards may require installation of an external manual shut-off valve if required, the manual valve must be located outside the confines of the furnace casing except if shut-off is supplied as part of the furnace.

## **SEQUENCE OF DIRECT SPARK IGNITION OPERATION**

1. When the thermostat calls for heat a delay of 15 to 30 seconds will elapse before the time delay relay energizes the fan motor.
2. As the fan motor reaches approximately 75% of the normal R.P.M. (within 1 to 2 seconds) the sail switch, in response to the air flow, will close allowing current flow to the direct spark ignition board.
3. The direct spark ignition board will send current to the gas valve and allow gas to flow to the main burner where it is ignited by a direct spark igniter.
4. If the thermostat is satisfied or turned down, the gas valve will close and the flame on the main burner will go out. The blower will continue to run for a short period of time and then shut-off. The purpose of this is to remove most of the remaining gases and heat from the exchanger.

## OPERATIONAL CHECKOUT

**IMPORTANT:** Failure to follow these lighting instructions exactly may result in damage to the furnace.

1. Set thermostat to "off" position.
2. Turn gas valve to "off" position (if furnace is so equipped). Wait 5 minutes. (Gas valve is located behind front door panel. To remove pull forward at the bottom of door) and lift off.
3. Turn gas valve to full "on" position. Correct operation of the furnace depends on this valve being in the full "on" position. Never attempt to operate the furnace with valve partially closed. (If furnace is equipped with a shut-off).
4. Set thermostat to the desired temperature. Furnace will now operate automatically. When the thermostat calls for heat a delay of 15 to 30 seconds will occur before the fan motor is energized.
5. Allow 15 seconds for burner to ignite.
6. If burner does not ignite set thermostat to the "off" position. Wait 60 seconds and reset to "on" position.
7. If ignition is not obtained after three tries, go to complete shut-down and determine cause.

**FOR COMPLETE SHUT-DOWN, TURN GAS VALVE KNOB TO "OFF", (IF FURNACE IS SO EQUIPPED). SET THERMOSTAT TO "OFF" SETTING.**

## SEQUENCE OF PILOT OPERATION

When the wall thermostat contacts close, a time delayed relay is energized. After a 15 second delay the motor starts turning the circulating and combustion wheels. When the blower reaches the R.P.M.'s necessary to close the air operated sail switch, power is supplied through a temperature limit switch to open the main gas valve. The burner is then ignited by the pilot flame. When the wall thermostat contact opens, the fan relay is de-energized, the gas valve closes and the blower motor stops running after 45 seconds to 2 minutes. This is a cool down period and is normal.

### OPERATIONAL CHECKOUT:

**IMPORTANT:** Failure to follow these lighting instructions exactly may result in damage to the furnace.

To place furnace into operation.

1. Press gas valve knob in and turn to "off."
2. Set thermostat to highest setting (if thermostat has an "on/off" switch, turn to "on") and wait 5 minutes.
3. Turn gas valve knob to pilot position. NOTE: Blower should be running.
4. Press gas valve knob in and light pilot by pushing in on ignitor repeatedly until pilot lights. Hold gas valve knob in for one minute or until pilot remains lit.
5. Set thermostat to desired setting (fan should be running), then turn gas valve knob to "on" position.
6. For complete shut-down: Turn gas valve knob to "pilot" position, depress and turn to "off" position and thermostat to lowest setting or switch to "off" position.

# SHORT CIRCUIT CHECKOUT

If a fuse is blown or circuit breaker is tripped, a short is indicated and should be checked.

1. Turn off all appliances including the furnace.
2. Install an ammeter on the positive (+) lead of the battery. The meter reading should be 0. If an amperage reading ceases, the furnace electrical system is shorted or mis-wired, amp should be checked. See wiring diagram.
3. Refer to the operation and service instructions for a complete checkout.

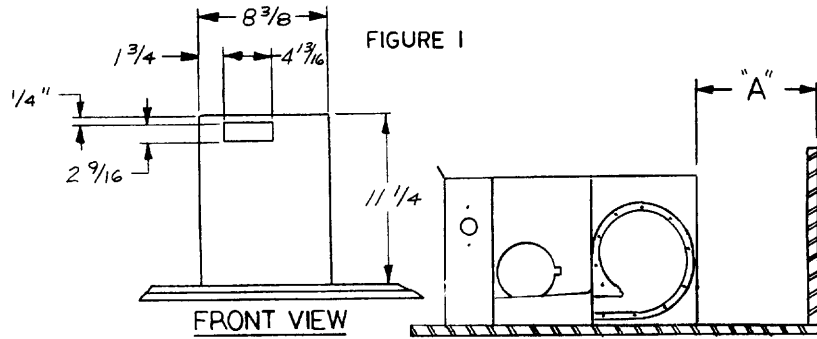

## 79/80 VENT KIT

MODELS	"A" DIM.		CABINET DEPTH		VENT KIT NO.	EXTENSIONS	
	MIN.	MAX.	MIN.	MAX.		EXH. TUBE	AIR BOX
FA 79	0"	3-1/2"	20-5/8"	23-3/4"	2150	1680	1677
HF 80	3-1/2"	7-1/2"	23-3/4"	28-5/8"	2151	1679	1676
	7-1/2"	11-1/2"	28-5/8"	32"	2145	1678	1675

FIGURE 2

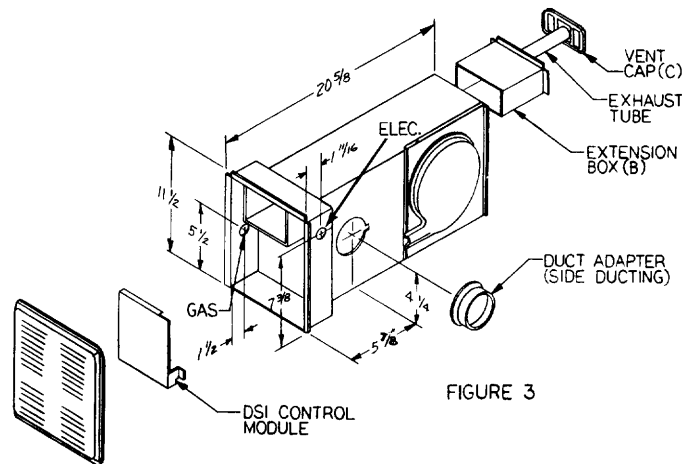

FIGURE 3

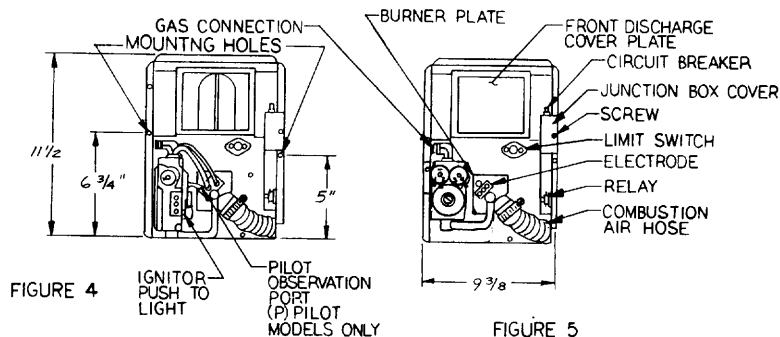

FIGURE 4

FIGURE 5

