

DUO-THERM

INSTALLATION & OPERATING INSTRUCTIONS

ROOF MOUNT AIR CONDITIONER
MODELS 600215-001, 600315-001,
600212-001, 600312-001, -002

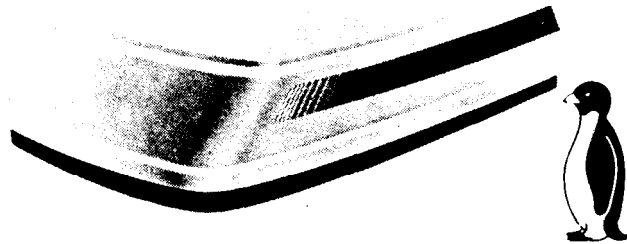

Pre-Wired For Optional Heat Package

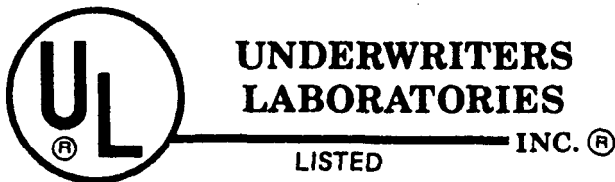

WARNING

THIS UNIT MUST BE SERVICED BY AN AUTHORIZED SERVICEMAN. MODIFICATION OF THE APPLIANCE CAN BE EXTREMELY HAZARDOUS AND COULD LEAD TO SERIOUS INJURY OR DEATH.



AVIS:

CET appareil doit être réparé seulement par un réparateur autorisé. Modification de l'appareil pourrait être extrêmement dangereuse, et pourrait causer mal ou mort.

**-IMPORTANT INSTRUCTIONS-
MUST STAY WITH UNIT
OWNER-READ CAREFULLY**

I**GENERAL SPECIFICATIONS & NOTICES****SPECIFICATIONS**

MODEL NO.'S	600215 600315	600212 600312	Optional Heater
Nominal BTUH Capacity	13,500	11,000	5600
Electrical Rating	115V, 60 Hz. 1 Ph		
FL Amps (Comp/Motor)	12.4/3.1	10.1/3.1	12.7
LR Amps (Comp/Motor)	63.5/8.3	56.6/8.3	-- --
Kilowatts	1.7	1.5	1.53
Min. Wire Size	Up to 24'. use 12 AWG, Copper		
Circuit Protection	20 Amp Time Delay Fuse or 20 Amp Circuit Breaker, HACR Type		
**Normal Min. 1 Unit	3.5KW	2.5KW	3.5KW
Generator Size 2 Unit	5.0 KW	4.0KW	5.0KW

- * The Duo-Therm Corporation gives only general guidelines for Generator requirements. These Generator requirements come from experience consumers have with our equipment in field applications. When sizing the Generator, the total electrical power consumption of the Recreational Vehicle must be taken into consideration. Keep in mind that Generators lose power because of altitude increases above sea level and lack of maintenance.

This Air Conditioner is Listed by Underwriters Laboratories, Inc. as complying with UL Standard 484.

Reference is made through out these instructions to Optional Electric Heater. This heater is an accessory to the Air Conditioner and can be purchased by requesting Electric Heater Kit No. 3-18706. This heater is installed in the air box of the Air Conditioner and the installation instructions are packed with the heater.

II**PRECAUTIONS FOR SAFE INSTALLATION**

- A. Read installation and operating instructions thoroughly and carefully before attempting installation of Air Conditioner.

WARNING: IMPROPER INSTALLATION MAY DAMAGE EQUIPMENT, COULD ENDANGER LIFE, CAUSE SERIOUS INJURY AND/OR PROPERTY DAMAGE.

- B. The Duo-Therm Corporation will not be liable for any damages or injury due to failure to follow these installation and operating instructions.
- C. Installation must comply with the National Electric Code and all applicable State and Local Codes and/or Regulations.
- D. **DO NOT** add any devices or accessories to this equipment except those specifically authorized by The Duo-Therm Corporation.

- E. This equipment must be serviced only by qualified service personnel. Some states require installation and service personnel to be licensed.

III**LOCATION OF AIR CONDITIONER ON RECREATIONAL VEHICLE**

This Air Conditioner is designed to be installed on the roof of a Recreational Vehicle. One or more units may be installed on the vehicle, dependent upon the size and strength of the roof and the expected cooling requirements of the RV.

- A. Normal Location of Air Conditioner(s)
(Refer to FIG. 1)

Normally the Air Conditioner(s) is installed in an existing roof vent. When the roof vent is removed it normally creates a 14" x 14" opening through the roof required for the installation of the Air Conditioner(s).

- B. Other Locations for Air Conditioner(s):
When no roof vent location is available or a roof vent location is not to be used, it is recommended that the Air Conditioner(s) be installed as follows:
1. For one unit installation: Air Conditioner should be mounted slightly forward of center (front to back) and centered from side to side on the RV.
 2. For two unit installations: Install one Air Conditioner 1/3 and one Air Conditioner 2/3 back from front of RV and centered from side to side.

In ALL CASES the Air Conditioner(s) MUST be mounted in a relatively FLAT AND LEVEL section of the roof when the RV is parked on a level surface.

- C. After Location Selection
(Refer to FIGS. 2 & 3)

1. Check on RV roof to be sure no obstructions are in the area where the Air Conditioner will be installed.
2. Check inside RV where Air Conditioner Air Box will be located to insure there will be no interference with door openings, curtains, room dividers, etc.
3. Be sure your RV roof structure is capable of supporting a weight of 130 lbs. when the RV is in motion. (Normally if roof can support a static load of approx. 200 lbs. it meets this requirement.)

IV**ROOF PREPARATIONS**

- A. Roof Vent Locations
1. Remove all screws that secure roof vent to roof and remove vent from opening.
 2. Remove all caulking compound from around vent opening.
 3. Seal all screw holes where vent was attached to roof and all roof seams in the area with a good grade of all weather sealant.

B. Other Than Roof Vent Locations
(Refer to FIG.4)

If other than a roof vent location for the Air Conditioner(s) was selected, a 14" x 14" opening must be cut into the roof and ceiling of the RV. It is recommended that this opening be located between roof reinforcing members.

CAUTION: Disconnect all power supplies to RV and disconnect positive battery terminal from the RV battery before performing any cutting on the RV surface. FAILURE TO FOLLOW THIS INSTRUCTION MAY CREATE A SHOCK HAZARD.

1. Mark 14" x 14" opening on roof of RV with marker.
2. Carefully cut opening in roof of RV.

CAUTION: There may be electrical wiring located between roof and ceiling.

3. Carefully cut a matching hole through the ceiling of the RV.

C. Opening Preparations
(Refer to FIG. 4)

1. If the opening exceeds 14" x 14", it will be necessary to make the opening smaller by installing spacers or close off plates.
2. If the opening is smaller than 14" x 14", it will be necessary to enlarge the opening.
3. Route a grounded power supply line from circuit breaker or fuse box to the roof opening.
 - a. The power supply must be a separate circuit, fused with a 20 Amp Time Delay Fuse or 20 Amp Circuit Breaker, HACR Type.
 - b. The power supply must be grounded 12AWG COPPER supply for distances of 24' or less.
 - c. The power supply wiring must comply with National, State and Local wiring codes.
 - d. Depending on entrance location, up to 20" of wire must extend into 14" X 14" opening to insure ease of attachment to the air conditioner.
 - e. If vent fan was removed, the existing wire may be utilized, provided it is of proper size and properly fused.
4. Framing is required around the 14" x 14" opening to insure adequate support, provide a smooth surface for sealing and prevent hot or cold air from being drawn into opening. This framing should be wood strips 15' x 1" x thickness of roof to ceiling distance. A hole for the power supply must be provided.

NOTE: Under no circumstances should the roof be constructed to create a low spot where water will accumulate when the Air Conditioner is installed. This may create a water leak into the interior of the RV.

5. You will find a return air duct in the carton with the Air Conditioner. This air duct is a piece of sheet metal folded flat.
 - a. Unfold and form this into a 14" x 14" square.
 - b. Insert into the opening in the roof and align the hole in duct with the hole for the electrical power supply wire.
 - c. Trim off excess sheet metal above and below the roof and ceiling of the RV.

V

PLACING OF AIR CONDITIONER(S)
ON ROOF

- A. Remove the carton from the Air Conditioner and discard.
- B. Lift unit up and place over the prepared 14" x 14" opening. The blunt end of Air Conditioner goes toward the rear of the RV. (Refer to FIG. 2).

CAUTION: DO NOT slide the air conditioner across the roof. There is a neoprene rubber gasket attached to the bottom of the air conditioner which may be damaged by sliding. A torn or damaged gasket may not seal the air conditioner to the roof of the RV.

- C. Locate the rubber gasket as near as possible to centered over the 14" x 14" opening.

This completes the outside work. Minor adjustments to Air Conditioner location may be done from the inside of the RV.

VI

UPPER DISCHARGE AIR DUCT
INSTALLATION (Refer to FIG. 4)

The Upper Discharge Air Duct is shipped inside the Lower Discharge Air Duct attached to Ceiling Template. Use two of the six sheet metal screws to attach the Upper Discharge Air Duct to the bottom of the Air Conditioner. They are in the bag of installation hardware.

- A. Remove the upper duct from the ceiling template duct and install it over the blower discharge opening.

Note: The edge without the flange goes toward the rear of the RV.
- B. Secure the duct in place with the two screws provided. There are prepunched holes in the basepan for ease of installation.

VII

CEILING TEMPLATE INSTALLATION
(Refer to FIG. 4)

- A. Reach through the 14" x 14" opening and adjust the Air conditioner until the gasket is centered on the opening.
- B. Measure the distance from the bottom of Air Conditioner to the ceiling surface:
 1. If the distance is 1" to 2", remove perforated tabs on the Upper Discharge Air Duct and tabs on the Lower Discharge Air Duct.
 2. If the distance is 2" to 3", remove perforated tabs on the Lower Discharge Air Duct.
 3. If the distance is 3" to 4 1/4", do not remove any of the perforated tabs.
 4. If the distance is greater than 4 1/4", an optional duct, Part No. 3-18556, and bolt kit, Part No. 3-18557, are available.
- C. Take the ceiling template and slide the lower discharge air duct over the outside of the upper discharge air duct.
- D. Holding the ceiling template in place with one hand, install the three 1/4" x 6" mounting bolts up through the ceiling template and into the air conditioner with other hand, until mounting bolts are finger tight. (See FIG. 5 for location of bolts).

FIG. 4

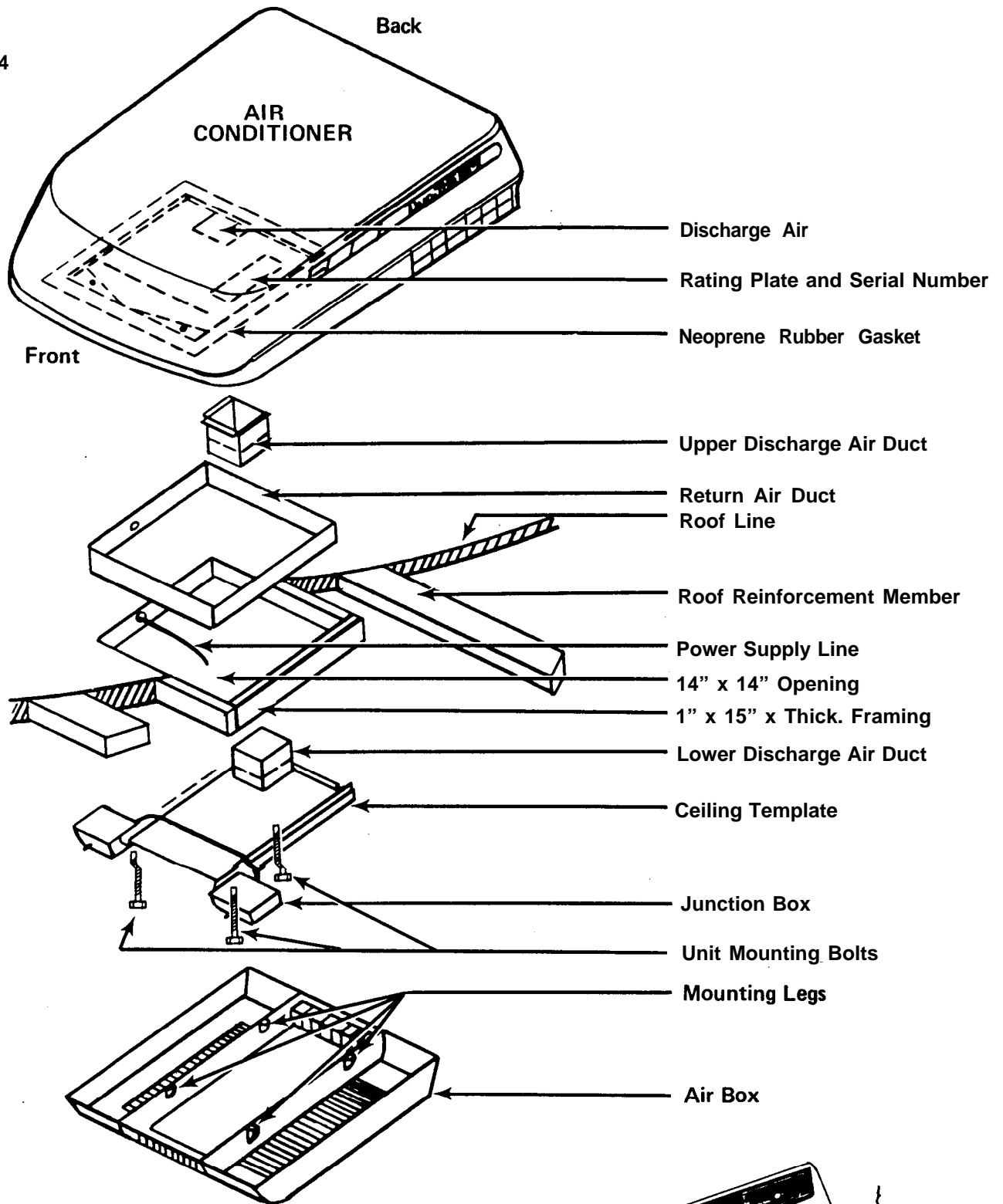

NOTE:

Remove the return air grilles by placing a flat bladed screw driver or similar tool into the latches. By using a prying motion, the grilles are easily removed. NOTE: Two latches, on either side, must be unhooked.

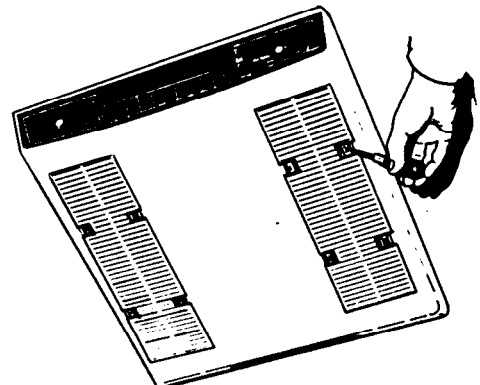

- E. Evenly tighten the three mounting bolts to secure the air conditioner to the roof. The mounting bolts should be tightened to a torque of 40 to 50 in. lbs. to insure adequate air conditioner to roof seal.

CAUTION: DO NOT overtighten the mounting bolts as this may damage the air conditioner base.

VIII CONNECTION OF: POWER SUPPLY TO AIR CONDITIONER (Refer to FIG. 5)

CAUTION: Be sure power supply is OFF before connecting power supply leads to the air conditioner.

- A. Route the power supply line, previously installed to the 14" x 14" opening, into the junction box on the ceiling template.
- B. Connect power supply line to air conditioner leads with three twist connectors provided. Connect white to white, black to black and green to green or bare copper wire.
- C. Using electricians tape, tape twist connectors firmly to wires.
- D. Tighten the strain relief onto the power supply line, to hold it firmly in place.
- E. Carefully push excess wire back into junction box and install cover onto box with screw provided. (The one blunt point screw in the mounting hardware).
- F. Plug the electrical conduit hanging from the bottom of the air conditioner into the mating connector on the switch box located on the ceiling template.

NOTE: If optional heater is part of this installation, follow the instructions provided with the electric heater kit.

IX AIR BOX INSTALLATION (Refer to FIG. 4)

- A. Remove the two return air grills and filters which are shipped loose in the air box.
- B. Slide the front end of the air box over the shafts of the thermostat and selector switch.
- C. Install the four screws through legs in air box into the prepunched holes in the ceiling template. **NOTE:** There are four optional mounting holes for which no screws are provided.
- D. Install the return air grills and filters by simply pushing them into place.
- E. Install the two knobs provided on the ends of the thermostat and selector switch shafts.
- F. The power supply to the air conditioner may now be turned ON.
- G. Your air conditioner is now installed and ready for operation. Please read the following instructions before attempting to run unit.



OPERATING INSTRUCTIONS (Refer to FIG. 6)

- A. Controls
 1. Thermostat (Dial on right side when facing air box) has a temperature range of 65°F in COOL position to 90°F in WARM position. The thermostat controls the unit compressor ON and OFF cycle in the cooling mode and the electric heater ON and OFF cycle in the heating mode.
 2. Selector Switch (Dial on left side when facing air box) controls the unit fan speeds, heating mode, cooling mode and fan mode of operation.

- B. Cooling Operation
 1. Set the thermostat to the position which will give your desired comfort level.
 2. The selector switch is to be set as follows:
 - a. **HIGH COOL:** Selected when maximum cooling and dehumidifying is required.
 - b. **MED COOL:** Selected when medium cooling is required.
 - c. **LOW COOL:** Selected when minimum cooling is required. Normally this position is selected for night time operation.

The air conditioner compressor will come on and off as cooling is required to maintain your desired temperature level as set at the thermostat.

NOTE: The air conditioner blower runs continuously to circulate the air and maintain an even temperature in the RV. It does not come on and off with the compressor.

- C. Fan Operation

When you wish to circulate the air inside your RV, without heating or cooling, select one of the three fan speeds (HIGH FAN, MED FAN or LOW FAN). The fan will run continuously and circulate the air in the RV.

- D. Heating Operation: (With Optional Electric Heater Installed).

NOTE: This electric heater will not replace a furnace for heating your RV in cold weather. It is intended to remove the chill from the air on cool days or mornings only.

1. Set the thermostat to position which will give your desired comfort level.
2. The selector switch can be set in any of the three heating positions, but normally it will be placed in the LOW HEAT position for best results.

The electric heater will turn on and off as heating is required to maintain your desired temperature level as set at thermostat.

NOTE: The air conditioner fan runs continuously to circulate the air in the RV. It does not come on and off with the heater.

- E. Operation of air conditioner WITHOUT Optional Electric Heater installed.

When the optional electric heater is not installed in the air conditioner and the selector switch is in one of the heating positions (HIGH HEAT, MED HEAT or LOW HEAT) the air conditioner works as if it were in Fan Operation. No damage will be caused to the air conditioner when these positions are used.

- F. **Off Position**
To shut the air conditioner OFF place the selector switch in the OFF position.
- G. **Compressor Time Delay Models:**
When the 6002XX Series Air Conditioners are turned on the fan starts immediately. When the thermostat calls for cooling, there is a 2 minute delay before the compressor starts. This is to reduce the load on the power supply and prevents short cycling of the compressor.
- H. **Compressor Non-Time Delay Models:**
When the 6003XX Series Air Conditioners are turned on and the thermostat calls for cooling, the fan and compressor start at the same time. After shutting the air conditioner down manually by either the selector switch or the thermostat, always wait at least 2 to 3 minutes before turning the air conditioner back on. This allows the refrigerant pressures in the air conditioner to equalize so the compressor may restart.

XI MAINTENANCE

AIR FILTERS: Periodically remove the return air filters located above the removable panels in the air box. Wash the filters with soap and warm water, let dry and then reinstall.

Note: Never run the air conditioner without return air filters in place. This may plug the unit evaporator coil with dirt and may substantially affect the performance of the unit.



SERVICE-Unit Does Not Operate

If your unit fails to operate or operates improperly, check the following before calling your service center.

- A. If RV is connected to motor generator, check to be sure motor generator is running and producing power.
- B. If RV is connected to power supply by a land line, check to be sure line is sized properly to run air conditioner load and it is plugged into power supply.
- C. Check your fuse or circuit breaker to see if it is open.
- D. In the air conditioner air box, check to be sure the air conditioner conduit is plugged into the selector switch box.
- E. After the above checks call your local service center for further help. This unit must be serviced by qualified service personnel only.

When calling for service always give the air conditioner Model Number and Serial Number. This information can be found on unit rating plate located on the air conditioner base pan. To locate, remove return air grill from air box and look up through 14" x 14" opening in ceiling. (See FIG. 4).

WIRING DIAGRAM

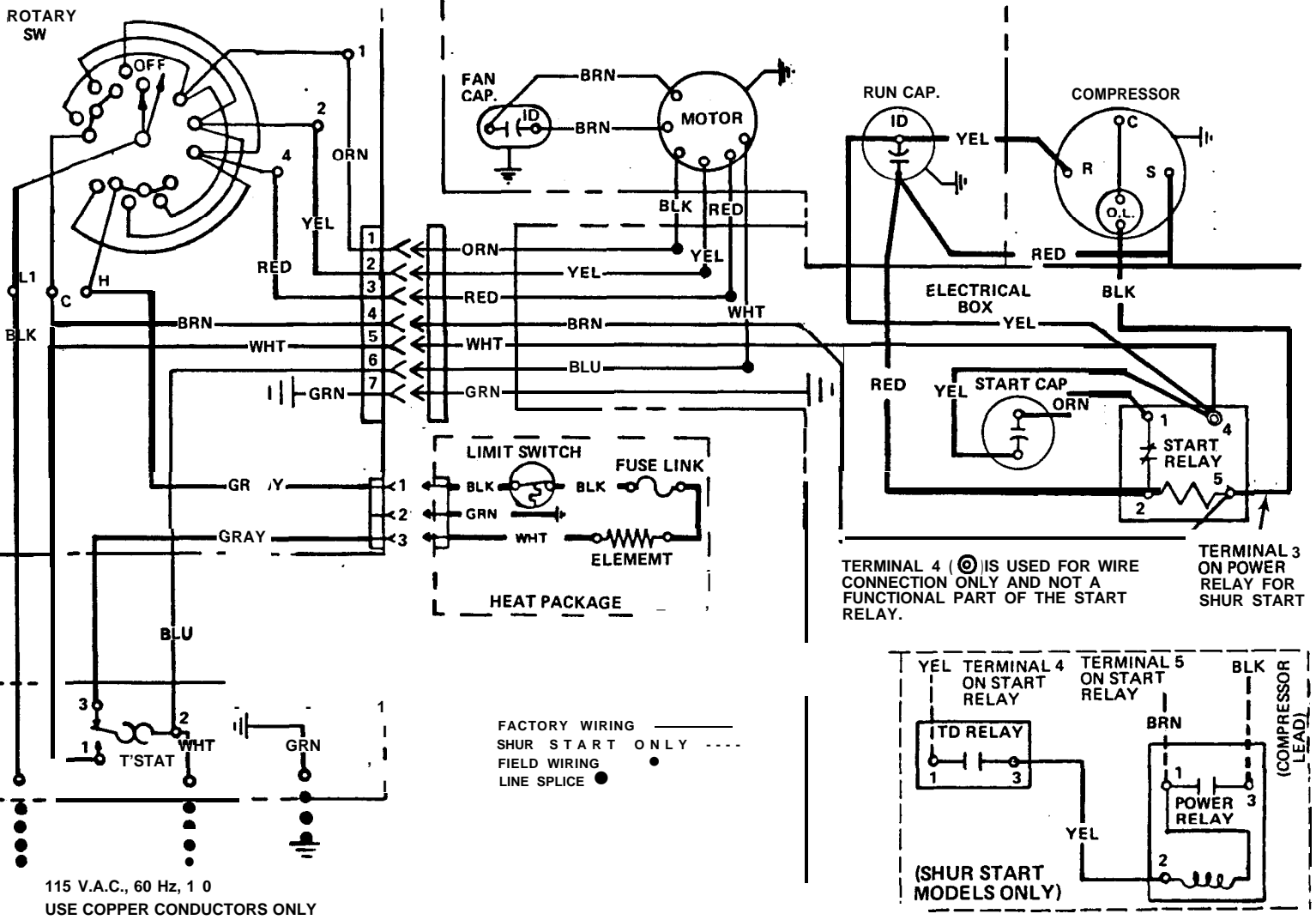

WIRING SCHEMATIC

