



Dometic

INSTALLATION AND OPERATING INSTRUCTIONS

REFRIGERATOR FOR LP-GAS AND ELECTRIC OPERATION.

RM2301 RM2401

RM2501

RM2601 RM2801

FOR YOUR SAFETY

If you smell gas:

- 1. Open windows.**
- 2. Don't touch electrical switches.**
- 3. Extinguish any open flame.**
- 4. Immediately call your gas supplier.**

FOR YOUR SAFETY

Do not store or use gasoline or other flammable vapors and liquids in the vicinity of this or any other appliance.

	Page
Installation	7-10
Instructions for use	11-12
Gas equipment	13
Electric equipment	13
Maintenance	14
Fault tracing	14
Door panel	last page

Dometic

quality leisure line products

Corporate Office
2320 Industrial Parkway Elkhart, IN 46515

USA

SALES OFFICES
Zone I
Elkhart, IN 46515
2320 Industrial Pkwy.
Phone: 219-295-5228

Zone II
Arlington, TX 76011
2920 Avenue "E" East
Phone: 817-649-5726

Zone III
City of Industry, CA 91746
14441 Bonelli Street
Phone: 818-968-9431

CANADA

Dometic Distribution Inc.
866 Langs Drive
Cambridge, Ontario
N3H 2N7 Canada
Phone: 519-653-4390

INSTALLATION

GENERAL INSTRUCTIONS

This appliance is designed for storage of foods and storage of frozen foods and making ice.

The refrigerators outlined hereon have been design certified under ANS Z21.19a- 1984 Refrigerators by the American Gas Association for installation in a mobile home or recreational vehicle and are approved by the Canadian Gas Association. The certifications are, however, contingent on the installation being made in accordance with the following instructions as applicable.

The installation must in the USA conform with:

1. National Fuel Gas Code ANSI Z223. I-I 984
2. Manufactured Home Construction and Safety Standard, Title 24 CFR, Part 32-80,
3. Recreational Vehicles ANSI/NFPA No. 501 C-1977

The unit must be electrically grounded in accordance with the National Electric Code ANSI/NFPA No. 70-1984 when installed if an external alternating current electrical source is utilized.

4. Any applicable local code



The installation must in Canada conform with

1. Current CGA B 149 Gas Installation Codes
2. Current CSA Standard Z 240.4 GAS - EQUIPPED RECREATIONAL VEHICLES AND MOBIL HOUSING
3. Any applicable local code

The unit must be electrically grounded in accordance with the current CANADIAN ELECTRICAL CODE C 22 Parts 1 and 2.

Ventilation

The installation shall be made in such a manner as to separate the combustion system from the living space of the mobile home or recreational vehicle. Openings for air supply or for venting of combustion products shall have a minimum dimension of not less than 1/4 inch.

Proper Installation requires one lower fresh air intake and one upper exhaust vent. The ventilation kits shown in this instruction booklet have been certified for use with the refrigerator models listed in the tables. **Certified vent system kits, see separate list.** The ventilation kits must be installed and used without modification. An opening towards the outside at floor level in the refrigerator compartment must be provided for ventilation of heavier-than-air fuel gases. The lower vent of the recommended kits is provided with proper size openings. The flow of combustion and ventilating air must not be obstructed.

For ready serviceability of the burner and control manifold parts of the refrigerator the lower side vent is fitted with a liftout panel which provides an adequate access opening.

GAS CONNECTION

Hook-up to the gas supply line is accomplished at the manual gas valve, which is furnished with a 3/8" SAE (UNF 5/8- 18) male flare connection. All completed connections should be checked for leaks with soapy water.

The gas supply system must incorporate a pressure regulator to maintain a supply pressure of not more than 11 inches water gage.

When testing the gas supply system at test pressures in excess of 12 psig the refrigerator and its individual shutoff valve must be disconnected from the gas supply piping system.

When testing the gas supply system at pressures less or equal 1/2 psig the appliance must be isolated from the gas supply piping system by closing its individual manual shutoff valve.

in case detailed Instructions on the installation and connection to the gas supply are required, contact your dealer or distributor.

ELECTRICAL CONNECTION

120 Volts A C

The refrigerator is equipped with a three prong (grounded) plug for protection against shock hazards and should be plugged directly into a properly grounded three prong receptacle. Do not cut or remove the grounding prong from this plug. The cord should be routed to avoid coming in contact with the burner cover flue cover or other hot components.

Refrigerator models requiring 12 V DC supply

On units provided with interior light or automatic reigniter or both there is one additional terminal block marked "12 V". On "Three Power" units with interior light or automatic reigniter or both there are two additional blocks.

The refrigerator must be connected to the battery circuit with two wires of adequate capacity to avoid voltage drop. The wire gage should be chosen with consideration to the wire length in accordance with table below. The 12 V circuit must be fused. Maximum circuit fuse size: 15 Amps. for the models RM2301 and RM2401, 20 Amps. for RM2501, 25 Amps. for RM2601 and RM2801.

Do not use the body or chassis of the vehicle as a substitute for either of the two conductors. No other electrical equipment or lighting should be connected to the refrigerator circuit. The refrigerator will draw from 10 to 18 Amps at 12 Volt depending on model. The interior light and the reigniter must be connected to a separate battery circuit and will draw about 1 Amp.

Maximum total conductor wire length in feet and meter.

AWG	RM 2301 125W	RM 2401 135W	RM 2501 175W	RM 2601 250W	RM 2801 275W	Interior light only 10W
14 ft. m	10 3	9 2,7	7 2.1	6.5 2	6.5 2	17 5.2
12 ft. m	17 5,2	15 4,6	12 3.6	10.5 3.2	10.5 3.2	35 10.7
10 ft. m	27 8,2	25 7,6	19 5.8	17 5.1	17 5.1	55 16.8
8 ft. m	43 13	40 12.2	31 9.5	27 8.1	27 8.1	85 25.9

CAUTION

Do not operate the refrigerator on 12 Volt when the vehicle is parked. You will run out of battery in a rather short time.

If possible the Installation of a 12 Volt operated refrigerator should be completed with a relay mounted either in the car or in the recreational vehicle (see Fig below). This relay will automatically cut out the refrigerator when the car motor is stopped

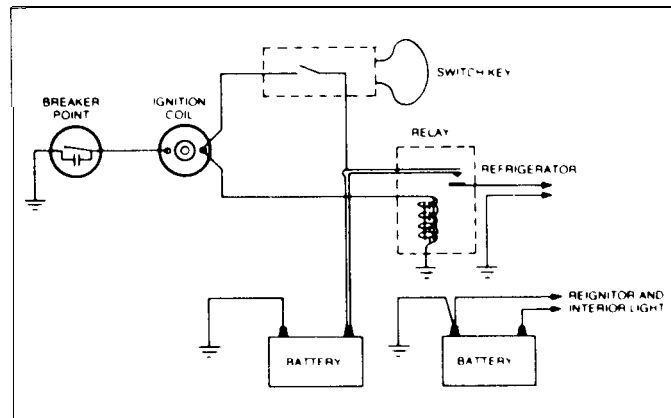

SPECIAL HINTS

Note. Do not install the appliance directly on carpeting. Carpeting must be protected by a metal or wood panel beneath the appliance which extends at least full width and depth of the appliance.

The refrigerator must be installed in a substantial enclosure and must be level. A spirit level is supplied with each refrigerator and by placing it in the freezer compartment one can level the refrigerator both ways front to back and side to side. When installing the refrigerator in the enclosure care should be taken to ensure a complete sealing between the front frame of the refrigerator and the top, sides and bottom of the enclosure. For this purpose a length of sealing strip is applied to rear surfaces of the front frame. A sealing strip should also be applied to the foremost floor of the enclosure as shown in fig 8. The sealing should provide a complete isolation of the appliance combustion system from the vehicle interior.

Be careful not to damage the sealing strip applied to the floor of the enclosure when the refrigerator is put in place.

In the front frame and in the base at the rear of the refrigerator there are holes for screws for fixing the refrigerator in the enclosure. See fig. 9.

Any space between counter or storage area and the top of the refrigerator greater than 1 1/2" should be blocked. The heat produced at the rear of the refrigerator will otherwise become trapped in this space making the top of the refrigerator hot and reducing the efficiency of the refrigerator.

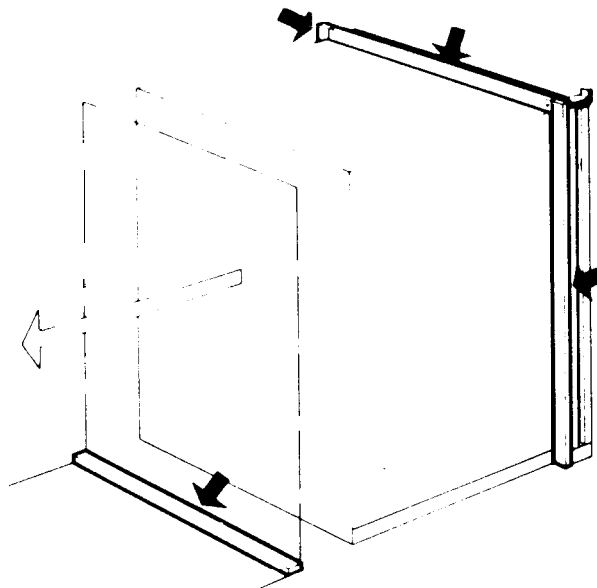

Fig.8

TO CHANGE THE DOOR, see last page

TO REMOVE AND REPLACE THE REFRIGERATOR

Before working on the refrigerator make sure that 120 V A. C. and optional 12 V D.C. Leads are disconnected. Shut the gas valve. Unscrew the hexagon nut 11 and move the valve on the gas line out of the bracket. Check that the valve slips out of the clip connection with the switch shaft.

Loosen the screws fixing the refrigerator to the enclosure and remove the refrigerator.

When replacing the refrigerator make sure that the sealing strips are properly positioned. After reassembly the gas connection should be checked for leaks.

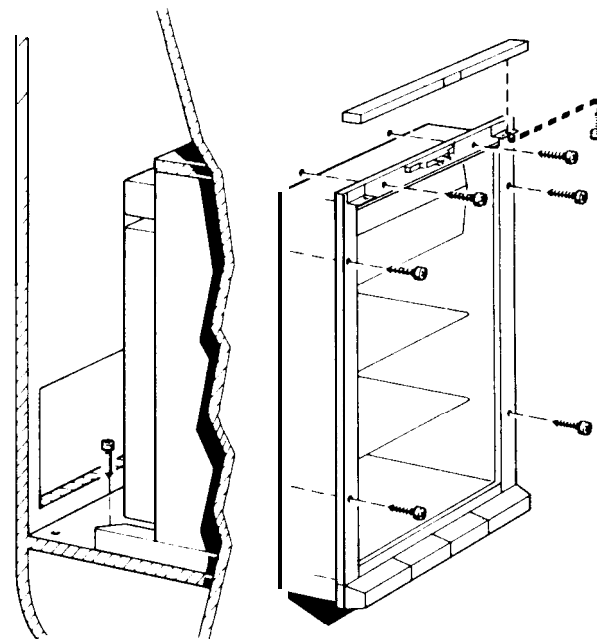

Fig.9

TEST OF THE GAS SAFETY SHUTOFF

The gas safety shutoff device must be tested after the refrigerator is placed in operation.

Refrigerator with piezo ignitor.

1. Start the refrigerator according to the instruction for gas operation with piezo igniter.
2. Check that the gas flame is lit. This can be observed through the reflector E.
3. Close the gas valve by turning the knob A back to position "OFF".
4. Wait 1 minute.
5. Remove cover plate, see (46) in fig. 1, Open the gas valve by turning the knob A to position "GAS" without pushing the button C and D. Test that no gas comes through the jet, item 38. Use soapy water. Be careful not to damage the jet.
6. After test rinse the jet with water. Once more be careful not to damage the jet. Assemble the cover plate. Start the refrigerator by following the Instruction for gas operation with piezo igniter. Normal gas operation should now return. Operate for at least 5 minutes.

Refrigerator with automatic reigniter.

1. Start the refrigerator according to the instruction for gas operation with automatic reigniter.
2. Check that the gas flame is lit. The lamp E is out.
3. Close the gas valve by turning the knob A back to position "OFF".
4. Wait 1 minute, disconnect 12 V D.C.
5. Remove cover plate, see (46) fig. 2 for RM2501 and (55) fig. 3 for RM2601/2801. Open the gas valve by turning knob A to position "GAS" without pushing the button C. The igniter shall not spark. Test that no gas comes through the jet, item 38. Use soapy water. Be careful not to damage the jet.
6. After test rinse the jet with water. Once more be careful not to damage the jet. Assemble the cover plate. Connect the 12 V D. C. again. Start the refrigerator by following the instruction for gas operation with automatic reigniter. Normal gas operation should now return. Operate for at least 5 minutes.

CERTIFIED INSTALLATION

Certified installations require one roof vent and one lower side vent or as optional one upper vent and one lower side vent. The two alternatives are provided for by using the different kits listed in the Appendix. For further information contact your dealer or distributor.

METHODS OF INSTALLATION

The methods of installation are shown in figures 10 a and 10 b. It is essential that all maximum or minimum dimensions are strictly maintained as the performance of the refrigerator is dependent on an adequate flow of air over the rear of the refrigerator.

VENTILATION HEIGHTS

Refrigerator model	Minimum ventilation heights in inches and mm	
	Installation with upper and lower side vent	Installation with roof vent and lower side vent
RM 2301	ft. 37 mm 940	31 787
RM 2401	ft. - mm -	34 864
RM2501	ft. - mm -	42 1067
RM 2601	ft. - mm -	56 1422
RM 2801	ft. - mm -	62 1575

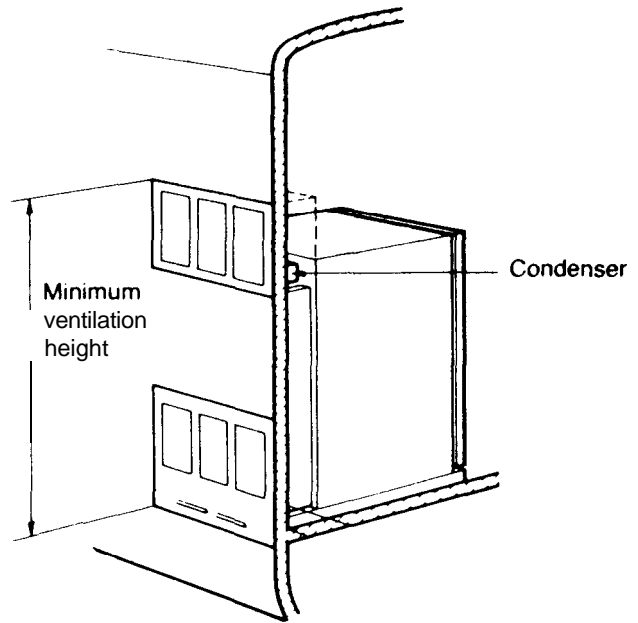

Fig. 10 a

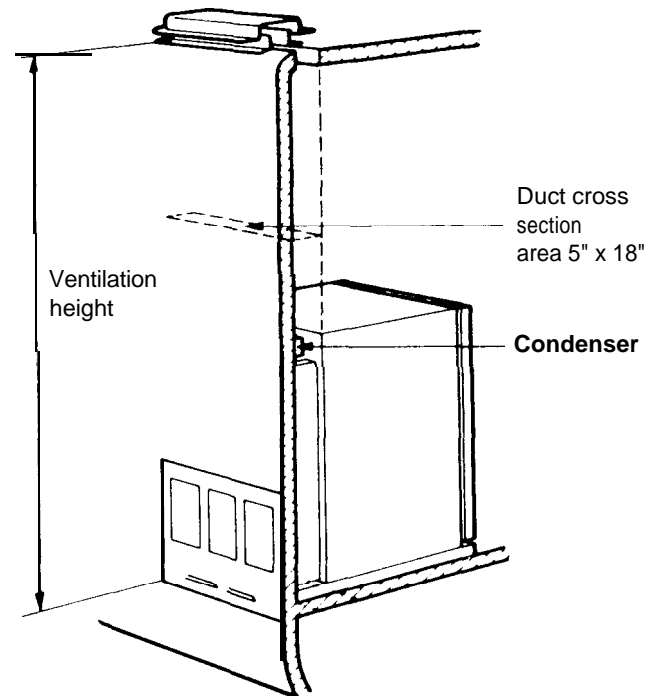

Fig. 10 b

CLEARANCES

Minimum clearances in inches to combustible materials are

- G: Top 0
- K: Side 0
- L: Bottom 0
- M: Rear 1
- N: See example below

Clearance M between the rearmost part of the refrigerator and the wall behind the refrigerator

Clearance N on top of the condenser is related to the minimum ventilation height

See Fig 11 and examples below

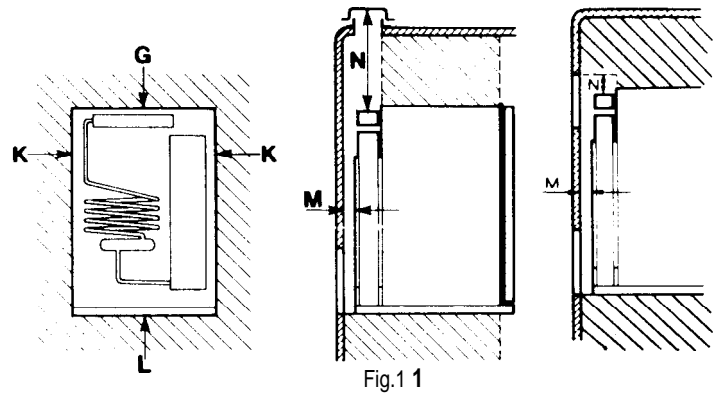

Fig.1 1

Refrigerator model	Overall dimensions			Installation dimensions			Recess dimensions			Distance between top of condenser and top of refrigerator e
	Height A	Width B	Depth C	Height h	Width w	Depth d	Height H	Width W	Depth D	
RM 2301	30 3/8 771	21 11/16 551	22 1/16 560	29 9/16 751	20 1/4 514	20 3/8 517	29 3/4 756	20 1/2 521	21 3/8 542	1 1/4 32
RM 2401	32 15/16 836	23 585	24 11/16 627	32 1/8 816	21 9/16 547	22 15/16 582	32 5/16 821	21 13/16 554	23 15/16 608	1 1/4 32
RM 2501	40 13/16 1036	23 585	24 11/16 627	40 1015	21 9/16 547	22 15/16 582	40 3/16 1021	21 13/16 554	23 15/16 608	1 1/4 32
RM 2601	52 1321	23 585	24 11/16 627	51 3/16 1300	21 9/16 547	22 15/16 582	51 3/8 1305	21 13/16 554	23 15/16 608	1 1/8 29
RM 2801	57 15/16 1471	24 15/16 633	24 11/16 627	57 1/8 1450	23 7/16 595	22 15/16 582	57 1/2 1455	23 13/16 605	23 15/16 608	1 1/8 29

This method of installation and these clearances will give you adequate space for servicing and proper installation.

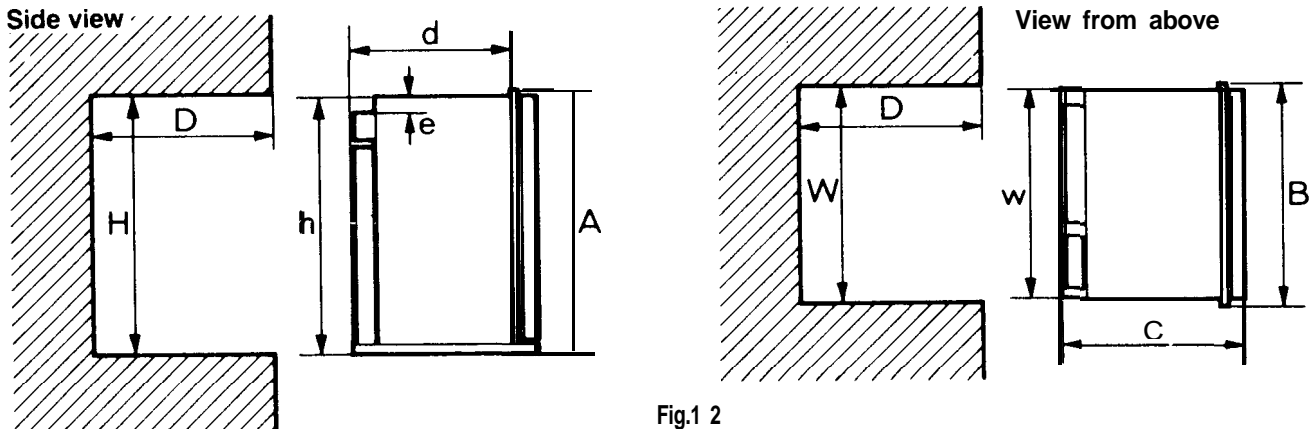

Fig.1 2

EXAMPLES

The clearance N for the RM 2301 model is derived at in the following way.

Installation with upper and lower side vents

N= Minimum ventilation height 37 minus installation height 29 9/16 plus distance between condenser top and refrigerator top 1 1/4

in: $N=37-29 \frac{9}{16}+1 \frac{1}{4}=8 \frac{1}{16}$ inches

mm: $N=940-751+32=221$ mm

Installation with roof vent and lower side vent

N=Minimum ventilation height 31 minus installation height 29 9/16 plus distance between condenser top and refrigerator top 1 1/4 plus distance between roof surface and roof vent cap 5 1/4

in: $N=31-29 \frac{9}{16}+1 \frac{1}{4}+5 \frac{1}{4}=7 \frac{15}{16}$ inches

mm: $N=787-751+32+134=202$ mm

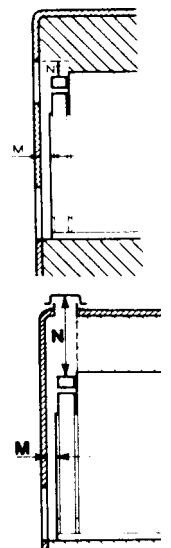

INSTRUCTIONS FOR USE

HOW TO START THE REFRIGERATOR

Leveling

In the boiler ammonia vapor is distilled from an ammonia-water mixture and carried to the fined condenser, where it liquifies. The liquid flows to the evaporator where it creates cold by evaporating into a circulating flow of hydrogen gas. If the evaporator coil is not level the liquid readily accumulates, forming pockets which can impair the gas circulation or even block it, in which case, of course, the cooling will stop. When the recreational vehicle is stationary it must be leveled to be comfortable to live in. If the refrigerator is properly installed, i e the freezer shelf parallel to the floor, the refrigerator will then also perform well. A double level should be placed on the freezer shelf. When the vehicle is on tow, the continuous rolling and pitching movement will not affect the refrigerator as long as the movement passes either side of level, but when the trailer is temporarily parked this sensitivity of the refrigerator should be remembered. So, once more, before you start the refrigerator make sure it is level.

Gas operation with piezo igniter

1. To start the refrigerator turn the knob A to position "GAS".
2. Turn the thermostat knob B a quarter of a turn from position "OFF"
3. Push the button C to stop and push the button D of the piezo igniter. The pushing has to be repeated until the gas is lit at the burner. This can be observed through the reflector E.
4. After the gas is lit keep the button C pushed for 10 seconds. Release the button and check through the reflector that the burner flame stays burning. If not repeat the lighting procedure. To shut off the refrigerator turn the knob A to off position.

NOTE: As soon as the necessary cold temperature inside the cabinet has been reached, adjust the thermostat knob to required setting.

Gas Operation with automatic reigniter

1. To start the refrigerator turn the knob A to position gas Lamp E comes on.
2. Turn the gas thermostat knob B a quarter of a turn from position "OFF".
3. Press the button C to stop and keep it depressed. When lamp E goes out wait 15 sec. and release button C. If the lamp comes on again, repeat the procedure. If flame blow out reignition will take place automatically. To shut off the refrigerator turn the knob A to off position.

NOTE: After a replacement of the gas container or a long shut off period the gas line is likely to be filled with air. In such a case the lighting procedure has to be repeated until the air is pushed out of the line and the gas has reached the burner.

Flame Blow Out

If trouble is encountered with the flame blowing out under specially windy conditions, try to avoid the wind blowing against the wall where vent outlets are located. If the trouble persists, set the thermostat to MAX. This later measure can of course only be temporary such as when the vehicle is on tow, for after a day or so at this setting the foodstuffs in the cabinet will freeze.

Electric Operation

1. Check that the attachment plug is correctly connected to the mains supply. When the refrigerator is equipped also for 12 Volts D C operation the low voltage connection is made at the marked terminals at the rear of the refrigerator.
2. Turn the knob A to desired position for electric operation.
3. Turn the thermostat knob B a quarter of a turn from position "OFF". To shut off the refrigerator turn the knob A to off position.

HOW TO USE THE REFRIGERATOR

Food Storage Compartment

The food storage compartment is completely closed and unventilated, which is necessary to maintain the required low temperature for food storage. Consequently foods having a strong odor or liable to absorb odors should be covered. Vegetables, salads etc should be covered to retain their crispiness. The coldest positions in the refrigerator are underneath the cooling evaporator and at the bottom of the refrigerator, and the least cold positions are on the upper door shelves. This should be considered when different types of food are placed in the refrigerator. The bottle retainer in the lowest door compartment is divided in two removable parts, see fig.

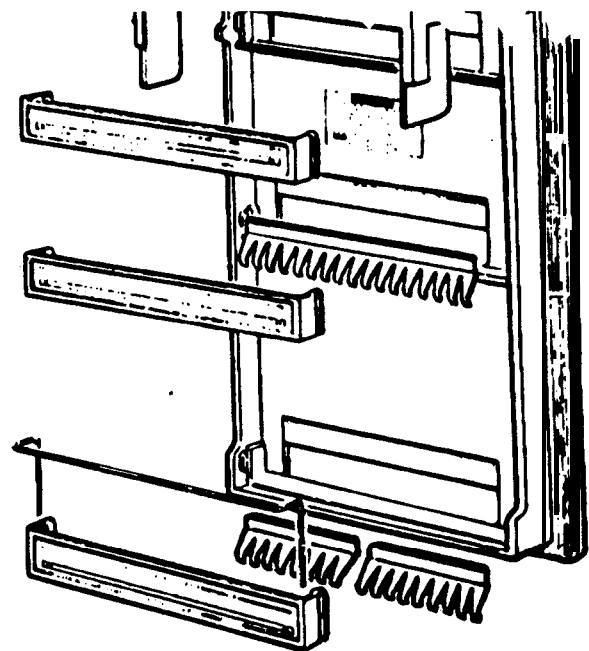

Door interior

Defrosting

Shut off the refrigerator.

Empty the refrigerator leaving the drip tray under the finned evaporator and the cabinet and freezer doors open. If desired, defrosting may be speeded up by filling the ice tray with hot water and placing it in the freezer. When the frost on the finned evaporator has melted water will be collected in the drip tray. The drip tray should be emptied at regular intervals. When all frost is melted, empty the drip tray and dry the interior of the refrigerator with a clean cloth. Replace the drip tray and ice tray, replace all food stuffs and set the thermostat to MAX for a few hours. Then reset the thermostat knob to its normal position.

Note: On the RM2801 the drip tray is placed on the rear side of the refrigerator.

Frozen Food Storage Compartment

The ice trays should be placed in direct contact with the freezer shelf for fastest ice making. Quick frozen soft fruits and ice cream should be placed in the coldest part of the compartment which is at the bottom of the aluminum liner or, in models with a shelf, on this or just below it. Frozen vegetables, on the other hand, may be stored in any part of the compartment. The compartment is not designed for the deep or quick freezing of food stuffs. Meat or fish foods, whether raw or prepared, and provided they are precooled in the refrigerator, can however, also be stored in the frozen food storage compartment. They can then be stored about three times as long as in the fresh food storage compartment. To prevent drying out, keep food in covered dishes, in plastic, bags or wrapped in aluminum foil.

Ice Making

Ice cubes can be made in the ice trays which should be filled with water to within 1/4" (5 mm) from the top. To release the ice cubes seize the tray with both hands and twist the tray. Cubes not required should preferably be replaced in the tray. Refill the tray with water and replace the tray on the freezer shelf. Ice making is accelerated if the thermostat knob is turned to setting "MAX". It is a good idea to do this a few hours before an anticipated need for ice but be sure to turn the knob back to normal setting when the ice is formed or the foodstuffs in the cabinet may become frozen hard.

To Shut Off the Refrigerator

To shut off the refrigerator turn the knob A to off position. If the cabinet is not in operation over a period of weeks, it should be emptied and cleaned and the door left ajar. Use the travel latch to lock the door in that position (see fig). Some models are provided with interior light, which comes on when the door is opened. To avoid running out of battery the light should be shut off with the switch on the side of the lamp housing. The ice trays should also be dried and kept outside the cabinet.

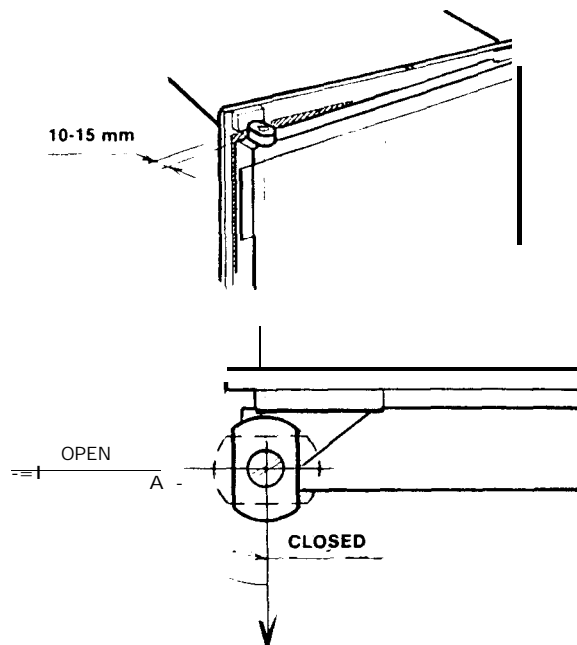

Travel latch for 1-door refrigerator

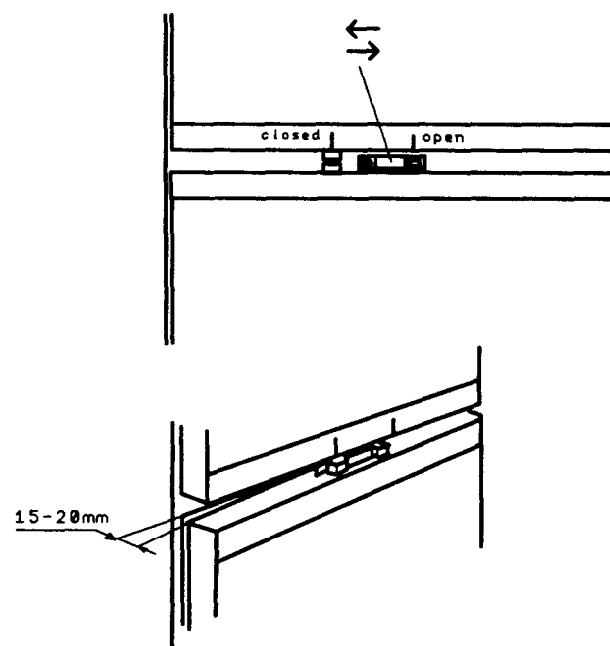

Travel latch for 2-door refrigerator

Cleaning

To clean the interior lining of the refrigerator use lukewarm weak soda solution. The evaporator, ice trays and shelves must, however, be cleaned with warm water only. Never use strong chemicals or abrasives to clean these parts or the protective surface will be damaged. It is important always to keep the refrigerator clean.

CAUTION

Do not store explosive substances in the refrigerator, such as cigarette lighter gas, petrol, ether or the like.

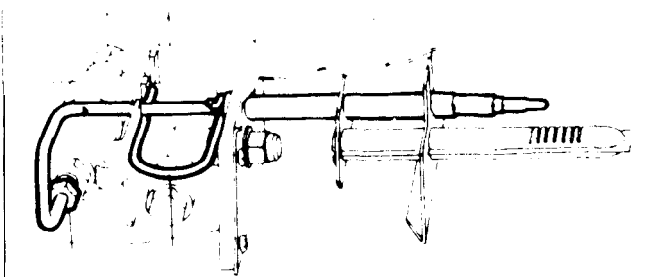

GAS EQUIPMENT

Flue Top and Baffle

The flue baffle is suspended from the top, and must be in position in the central tube of the cooling unit.

The Flame Failure Safety Device

The feeler of the thermo couple shall reach in over two slots of the burner. To replace the thermo couple proceed as follows:

1. Remove the cover.
2. Unscrew plug and pull thermo-couple straight out.
3. Remove spring.
4. Pull out thermo-couple sideways from burner housing.
5. Bend the new thermo-couple to the same shape as the old one.
6. Reassemble in reverse order. Check that feeler has been correctly refitted in relation to burner.
7. Mount plug, taking care not to damage the threaded hole in the aluminum cap of the housing. The plug must be properly tightened to the valve housing to ensure good contact between the thermo couple and the magnetic coil within the housing.

The Thermostat

The refrigerator is equipped with a thermostat which is regulated by turning the knob to different settings in order to obtain the desired controlled cabinet temperature.

At OFF Under normal operating conditions the thermostat valve remains closed and the burner is running continuously at the by pass rate, just enough to keep the burner lit.

At MAX The thermostat valve remains open and the burner is running continuously at full gas rate. Lowest cabinet and freezer temperatures are obtained at this setting.

Between these two extremes of the dial various controlled temperatures can be obtained, by turning the thermostat knob to a suitable position. The closer to MAX the lower the temperature. As soon as the required cold temperature inside the cabinet is reached. The thermostat cuts the burner main flame leaving the by-pass flame to keep safety valve open.

The Igniter

The refrigerator is fitted either with a piezo igniter (see fig.1) or an automatic reigniter (fig. 2 and 3) which does not normally need any maintenance. If the igniter does not work properly contact an authorized service point

ELECTRIC EQUIPMENT

Cartridge heater

The refrigerator is equipped also for electric operation. Many models are equipped for both 120 Volts A C and 12 Volts D C operation. The heat necessary for the operation of an absorption type cooling unit is supplied by an electric cartridge heater mounted on a pocket of the boiler system. To replace the heater first of course check that the wall plug is disconnected. If the refrigerator is equipped also for 12 Volts D C operation make sure that the 12 V leads are disconnected. Then proceed as follows:

1. Remove the cover of the main control structure by loosening the two screws
2. Disconnect the heater leads
3. Pull off the metal hose
4. With a pair of pliers unfold the lug holding the lid of the boiler casing and open the lid
5. Remove some insulation wool so that the heater is accessible
6. Turn and lift the heater out of its pocket
7. Fit the new heater into the pocket and pull on the hose around the leads
8. Connect the leads and put on the plastic cover
9. Reset the insulation and close the lid of the boiler casing

The Switch

The electronic control also comprises an on-off switch operated by the selector knob at the front panel. The switch has two "on" positions, one for 120 Volts A C (ELEC.) and one for 12 Volts D C operation.

The Thermostat

The electric thermostat is combined with the gas thermostat and is thus operated by the knob B at the front panel. The temperature in the refrigerator can be regulated by turning the thermostat knob. Although the exact setting is not critical choose a setting at which the frost which gradually forms on the cooling evaporator is just maintained in dry condition. It will be necessary to turn the thermostat knob closer to MAX when the ambient temperature becomes higher or the load unusually heavy. If less cooling is required a lower setting should be chosen.

PERIODIC MAINTENANCE

NOTE. Before working on the refrigerator make sure that 120 V A.C and optional 12 V D.C leads are disconnected.

Shut off gas valve.

The Burner and the Burner Jet

The color of the flame shall be clear blue over the slots of the burner. Once or twice a year depending on use, it is necessary to clean and adjust the burner assembly. Proceed as follows:

1. Loosen screw and remove cover plate for burner housing.
2. Disconnect lighter cable from the electrode.
3. Loosen burner fixing screw and withdraw burner.
4. Clean burner tube with a brush. Blow with compressed air.
5. Screw off jet and clean with alcohol. Blow with compressed air. Never use a needle or similar.
6. Reassemble.
7. Be careful that the end of the burner fits into the slot on the bracket. The slots of the burner must be centrally located under the boiler tube.

The Electrode

For a proper ignition function it is necessary to keep the electrode insulation dry and free from dirt. The gap between burner tube and electrode shall be max. 3/16" (5mm) and min. 1/8" (3mm).

WARNING

If the refrigerator is used intermittently it should be checked at least once a year. It is important to keep the appliance area clear and free from, combustible materials, gasoline and other flammable vapors and liquides. Check the venting system. The flow of combustion and ventilating air must not be obstructed. Check the flue baffle that it is clean and reasonably free from soot. Heavy soot formation indicates improper functioning of the burner. Clean baffle and flue. Further, clean cooling unit and floor under refrigerator. The entire gas installation should be checked for leaks at intervals. Test all pipe connections soapy water, not with an open flame.

NOTE. Any service of the gas controls, with exception for the above, mentioned replacement, maintenance and cleaning operations must be performed by an authorized service center only.

NOTE: Avoid water spraying through the refrigerators vents while washing your RV.

FAULT TRACING

The refrigerator does not freeze satisfactorily Causes and remedies

- a) Jet orifice clogged. Unscrew jet and blow clear or wash in alcohol. Do not use wire or pin to clean orifice.
- b) Check the leveling of the refrigerator.
- c) Flame has gone out. Remedy: 1) Gas in bottle is used up-refill. 2) Feeler point of the flame failure safety device is not heated enough by flame.
- 3) Clogged by-pass crew - clean or exchange it.
- d) Air circulation around cooling unit is restricted. Be sure that refrigerator is properly ventilated.
- e) The evaporator is heavily coated with frost. Defrost.
- f) Flue baffle not inserted into the central tube of the cooling unit
- g) The thermostat is incorrectly used. See paragraph on thermostat. In hot weather the setting should be closer to MAX than usual.
- h) Gauze in burner head clogged. Clean.
- h) Burner damaged. Replace.
- i) Burner may be dislocated. Relocate.
- j) Wrong gas pressure at the burner. Have pressure checked at burner at gas bottle. Pressure at burner must not fall below 11" W.G. when thermostat is set on MAX.

ODOR FROM FUMES

Causes and remedies

- a) The flame touches side of the boiler due to dislocation of the burr. Relocate. Burner dislocation may also cause smoke and discoloring of walls and ceiling.
- b) Burner damaged. Replace.
- c) The flame touches flue baffle. Remedy: 1) Burner damaged. Replace. 2) Flue baffle too low. Correct the position of the baffle.
- d) The flue tube is dirty. Clean flue as follows: Cover burner and jet Remove flue top and baffle. Clean flue with special flue brush. Clean baffle before putting back in place. All the above instructions are to be followed closely. The refrigerator is quality-guaranteed. However, we are not responsible for any failures caused by improper adjustments and unfavorable installation conditions. Contact service point or distributor service dep. for assistance. Replacement Parts Suppliers: See cover.

INSTRUCTIONS FOR MOUNTING THE DOOR PANEL

INSTRUCTIONS FOR MOUNTING THE DOOR PANEL

The refrigerator is normally delivered without door panel(s). Before starting the mounting work check that the panel dimensions are in compliance with those given in the table and read the instructions through. When mounting the panel, proceed as follows.

- Remove the door decoration list (2) with its two screws (1). The upper corners of the upper panel (2-door models) and the lower corners of the lower panel has to be cut according to the sketch.
- Insert one of the vertical edges of the panel into the groove of the door frame (3).
- Bend the panel gently so that the free side of the panel can be sled into the corresponding groove of the door frame (4).
- Push the panel downwards so that the lower horizontal edge of the panel is fitted into the bottom groove (5).
- Between the upper edge of the panel and the door frame there is now a gap which should be covered by the decoration strip.
- Put the strip across the door so that the gap is covered and pushed upwards (6). The tabs on the inside of the strip should fit in behind the flange of the door frame. Secure the decoration strip by means of the two screws (1).

Panel dimensions

Thickness max. 4 mm 5/32 inches

REFR. MODELS TYPE	HEIGHT		WIDTH	
	MAX.	MIN.	MAX.	MIN.
RM2301	mm 649	mm 647	mm 536	mm 534
	inch 25 17/32	inch 25 15/32	inch 21 3/32	inch 21 1/32
RM2401	mm 714	mm 712	mm 570	mm 568
	inch 28 3/32	inch 28 1/32	inch 22 7/16	inch 22 3/8
RM2501	mm 914	mm 912	mm 570	mm 568
	inch 35 31/32	inch 35 29/32	inch 22 7/16	inch 22 3/8
upper RM2601	mm 323	mm 321	mm 570	mm 568
	inch 12 23/32	inch 12 21/32	inch 22 7/16	inch 22 3/8
lower	mm 836	mm 834	mm 570	mm 568
	inch 32 29/32	inch 32 27/32	inch 22 7/16	inch 22 3/8
upper RM2801	mm 395	mm 393	mm 618	mm 616
	inch 15 17/32	inch 15 15/32	inch 24 5/16	inch 24 1/4
lower	mm 914	mm 912	mm 618	mm 616
	inch 35 31/32	inch 35 29/32	inch 24 5/16	inch 24 1/4

TO CHANGE THE DOOR OPENING FROM LEFT TO RIGHT OR VICE VERSA

Open the door and unscrew the two screws holding the top front cover. The screws are accessible from beneath. Remove the top hinge pin and lift out the door. The lower pin for the refrigerator door should be shifted to the opposite side.

The door can then be remounted. But before the front decoration check that the door closes well and the latch works properly. If not, correct the door by loosen the two screws for the upper hinge against the front frame and adjust. Then tighten the screws and replace the front decoration.

Lower door

Unscrew the hinge pin from the lower doors upper hinge. Lift the door from the bottom hinge pin and move the pin to opposite side. Replace the door and correct the doors locking position by means of the washers, if necessary adjust also the bottom hinge in the same way as the upper door.

