Foreword

This service manual is the result of the dedication of The Dometic Corporation and its engineers in giving service people the necessary instruction for making accurate analyses of certain conditions. Provided is a diagnostic chart leading a qualified mechanic into the service manual pages to locate and solve symptoms which may occur. Dometic has continued its commitment in providing service people with this, the most up-to-date information about servicing Dometic RV accessories.

CONTENTS PAGE NO.

RM2150,2190,2201 **SERIES DIAGNOSTIC FLOW CHART** 1

SECTION 1

OPERATION

1.1 RM2150 Operation 3
 1.2 RM2190 Operation 4
 1.3 RM2201 Operation 5

SECTION 2

AC VOLTAGE

AC VOLTAGE REQUIREMENTS 6

SECTION 3

AC COMPONENTS

3. Heating Element (RM2201) 6

SECTION 4

DC VOLTAGE

DC VOLTAGE REQUIREMENTS 6

SECTION 5

DC COMPONENTS

5.1 Switch 6
 5.2 Piezo igniter 6
 5.3 Electrode 6
 5.4 Heating Element 6
 5.5 Thermostat (RM2201) 7

SECTION 6

LP GAS

LP GAS REQUIREMENTS 7

SECTION 7

LP GAS COMPONENTS

7.1 Shut-Off Valve 7
 7.2 Filter 7
 7.3 Thermostat 8
 7.4 Safety Valve 8
 7.5 Thermocouple 8
 7.6 Burner 8
 7.7 Flue Baffle 8
 7.8 Crossover Tube 9
 7.9 Flue Tube 9
 7.10 Orifice 9

SECTION 8

WIRING

8.1 External Wiring 9
 8.2 Internal Wiring 9

SECTION 9

OTHER

9.1 Leveling 10
 9.2 Ventilation 10
 9.3 Air Leaks 11
 9.4 Door Position 11
 9.5 Ambient Temperature 11
 9.6 Cooling Unit 11
 9.7 Food Storage 11
 9.8 High Humidity 11
 9.9 Interior Liner Seal to Frame 11



This program will address the most common system problems associated with the RM2150/2190/2201 Manual Refrigerators supplied by The Dometic Corporation. Our intent is to provide you with a guideline of checks to make, should you encounter one of the following symptoms.

SYMPTOM	CAUSE	REFER SECTION	STEP
1. No AC operation, (RM2201)	Operation AC Volts Heating Element Thermostat Switch Wiring	1.3 2 3 5.5 5.1 8.2	B
2. No gas operation — no spark.	Operation Piezo Igniter Electrode Switch Wiring	1.1,1.2,1.3 5.2 5.3 5.1 8.2	A or B
3. No gas operation — sparks but no flame.	Operation LP gas Filter Orifice Burner Shut-off Valve Safety Valve Thermocouple	1.1,1.2,1.3 6 7.2 7.10 7.6 7.1 7.4 7.5	
4. No cooling on any mode.	Operation Ventilation Level Ambient Temperature Cooling Unit	1.1,1.2,1.3 9.2 9.1 9.5 9.6	
5. No cooling on gas — cools properly on other mode(s).	LP Gas Thermostat Filter Orifice Burner Flue Baffle Flue Tube	6 7.3 7.2 7.10 7.6 7.7 7.9	
6. No cooling on AC — cools properly on other mode(s). (RM2201)	AC Volts Heating Element Thermostat Switch Wiring	2 3 5.5 5.1 8.2	A or B
7. Insufficient cooling on all modes.	Operation Level Ventilation Ambient Temperature Air Leaks Thermostat Thermostat (RM2201) Cooling Unit	1.1,1.2,1.3 9.1 9.2 9.5 9.3 7.3 5.5 9.6	

SYMPTOM	CAUSE	REFER	STEP
		SECTION	
8. Insufficient cooling on AC — cools properly on other mode(s). (RM2201)	AC Volts	2	
	Heating Element	3	
	Thermostat	5.5	
9. Insufficient cooling on gas. Cools properly on other mode(s).	LP Gas Pressure	6	
	Thermostat	7.3	
	Filter	7.2	
	Orifice	7.10	
	Burner	7.6	
	Flue Baffle	7.7	
	Flue Tube	7.9	
10. Won't stay lit on gas.	LP Gas	6	
	Safety Valve	7.4	
	Thermocouple	7.5	
	Flue Baffle	7.7	
	Crossover Tube	7.8	
	Orifice	7.10	
	Burner	7.6	
11. No DC operation - cools properly on other mode(s).	DC Volts	4	A or B
	Heating Element	5.4	
	Switch	5.1	
	Wiring	8.2	
12. Insufficient cooling on DC- cools properly on other mode(s).	DC Volts	4	
	Heating Element	5.4	

SECTION 1

1.1 RM2150 OPERATION

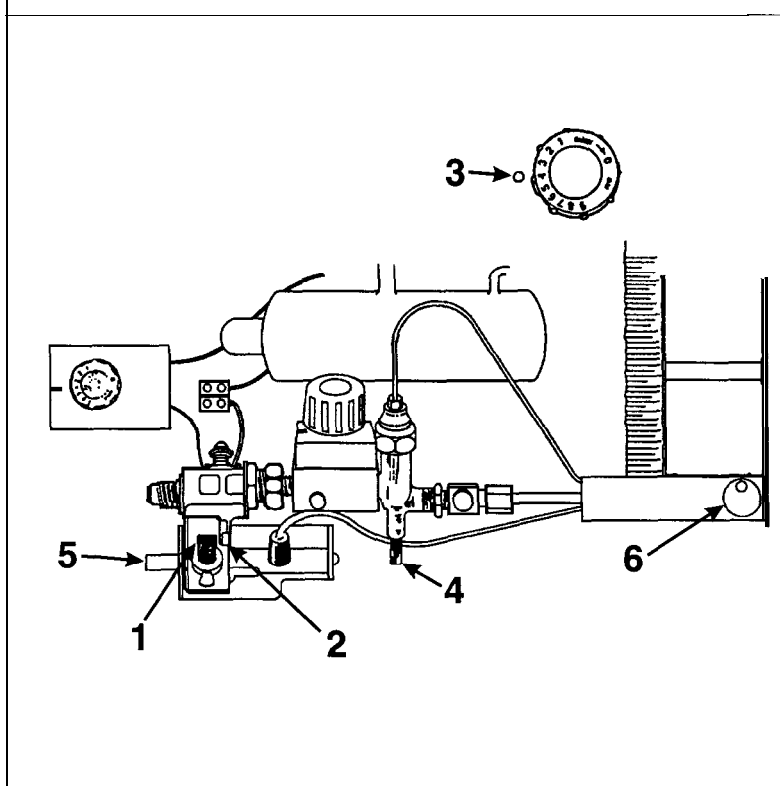

A. GAS OPERATION

- 1) Set 12 volt switch to "OFF".
- 2) Turn gas handle to left (so that handle is in line with gas valve body).
- 3) Turn gas thermostat knob to #4 setting.
- 4) Press gas safety valve plunger up and hold.
- 5) Push piezo igniter plunger in repeatedly until flame is observed at "6".
- 6) When flame is lit:
 - 1) Discontinue pushing the piezo plunger.
 - 2) BUT continue to hold up on the safety valve plunger for about 15 seconds.
 - 3) If flame goes out when plunger is released, repeat Steps 4 through 6.

TO SHUT GAS OPERATION OFF:

Turn handle (8) of the gas valve (5) away from the back of the cabinet.

The refrigerator has a flame failure device which will automatically shut off the gas to the burner if the flame is blown out. While plunger (10) is being held in, this device is temporarily inoperative.

DANGER - DO NOT hold this plunger in unless attempting to light the gas burner.

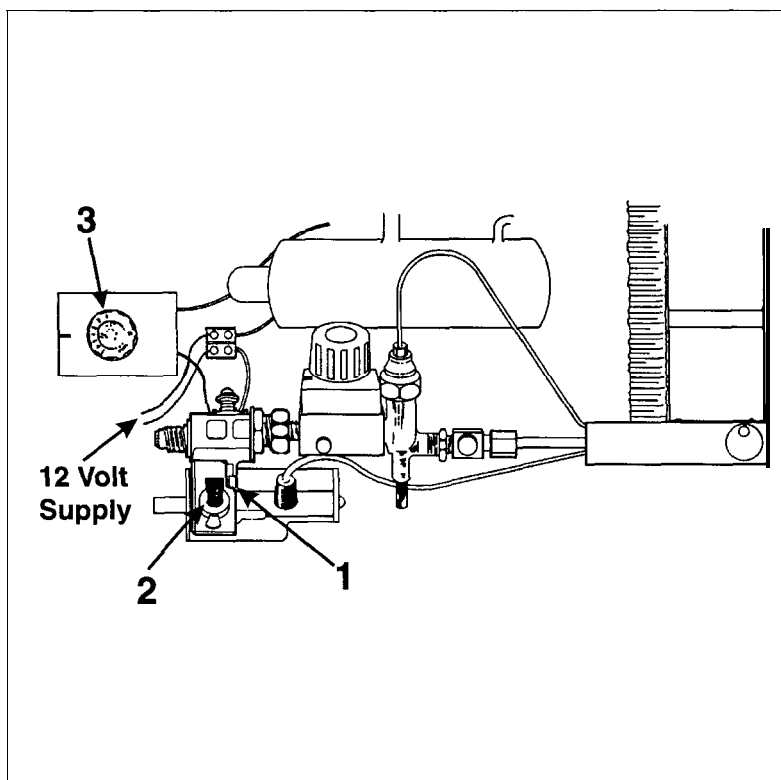

B. ELECTRIC OPERATION

The refrigerator may be operated on 12 volt DC only.

To start electric operation:

- 1) Turn gas valve to "OFF" position - handle pointed away from cabinet.
- 2) Switch the 12 volt DC toggle switch up to "ON" position.
- 3) Turn the electric thermostat knob to #4.

C. REGULATION OF TEMPERATURE

With thermostat knob set at either # 3 or #4, the cabinet will automatically maintain a suitable temperature for ordinary food. Usually, no further adjustment will be needed, but in hot weather, or when more cooling is required, the knob may be turned to a higher number. If less cooling is required, turn the knob to a lower number.

1.2 RM2190 OPERATION

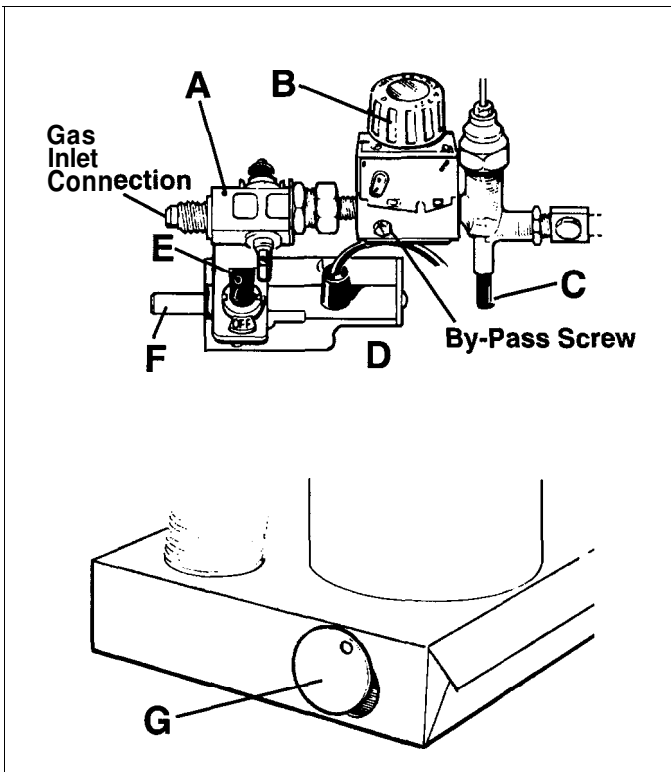

NOTE: The gas and electric controls are located at the rear of the refrigerator and are accessible through the lower vent in the wall of the vehicle. The gas valve and 12 volt toggle switch are interlocked to prevent simultaneous operation by gas and electricity.

A. GAS OPERATION

- 1) Open the lower vent at the rear of the refrigerator, on the outside of the vehicle, and set the 12 volt toggle switch (E) to "OFF". Turn on the gas valve (A) so that its handle (D) is in line with the gas valve body.
- 2) Turn the gas thermostat knob (B) to setting #4.
- 3) Push in the plunger (C) of the flame failure device for about 5 seconds to clear air from the lines. (When starting initially or after changing a gas bottle, it may be necessary to depress the plunger longer to clear all the air from the lines). Still pressing in the plunger (C), push in fully button (F) of the piezo igniter, several times in quick succession. (A click should be heard each time it is depressed). The burner should light, but continue to press in the plunger (C) for 15 seconds, then release it and check that the burner is lit by looking at the flame through the opening (G). If the burner has not lit, repeat the lighting procedure.

The evaporator should show signs of cooling after about an hour.

NOTE: If the gas has to be re-lit when the evaporator is still cold, the thermostat knob (8) must first be turned to MAX and returned to its normal setting only after the burner is lit. The refrigerator has a flame failure device which will automatically shut off the gas to the burner if the flame is blown out. While the plunger (C) is being held in, this device is temporarily inoperative.

TO SHUT DOWN: Turn the handle of the gas valve (A) away from the cabinet.

B. 12 VOLT ELECTRIC OPERATION

Before taking the vehicle on any road, turn off the gas cock (A) and, if required, use 12 volts to operate the cooling unit.

Whenever possible, the cabinet should be pre-cooled, together with its contents, by starting up and running the refrigerator on gas for several hours or overnight, before switching to 12 volt and starting on a trip.

The 12 volt heating element is rated at 95 watts and has a current consumption of 8 amps; therefore, the refrigerator should not be left operating on 12 volt when the engine is NOT running and charging the battery.

If an automatic cutout relay has not been installed, the refrigerator should be switched to "OFF" at the toggle switch soon after the engine is switched off, otherwise the battery may become discharged.

12 volt operation is not thermostatically controlled but overcooling is unlikely to occur because this mode of operation is used only for a few hours at a time.

DO NOT ATTEMPT TO OPERATE THE REFRIGERATOR BY BOTH GAS AND ELECTRICITY AT THE SAME TIME. ALWAYS ENSURE THAT ONE METHOD OF OPERATION IS TURNED OFF BEFORE USING THE ALTERNATIVE.

C. TEMPERATURE REGULATION (Gas Operation)

With the thermostat knob set at #3 or #4, suitable temperatures will be obtained for the storage of fresh foods and liquids under average conditions of use.

Usually, no further adjustments will be required, but, in hot weather, or when more cooling is desired, the knob should be turned to a higher setting (the higher the number-the lower [colder] the temperature).

If less cooling is required, turn the thermostat knob to a lower number.

1.3 RM2201 OPERATION

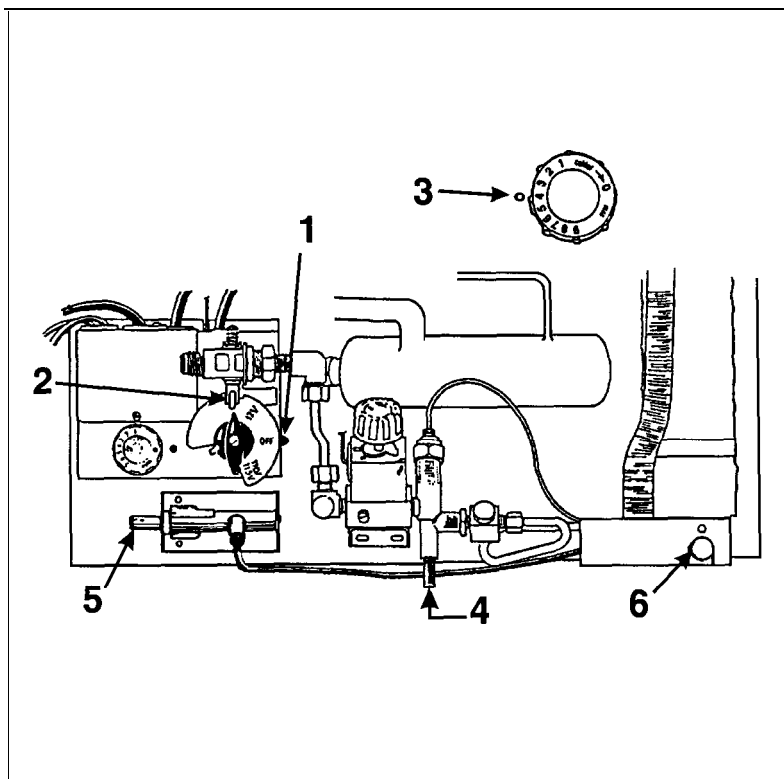

A. GAS OPERATION

- 1) Rotate selector to "OFF" position.
- 2) Turn gas handle to the left.
- 3) Turn gas thermostat knob to #4 setting.
- 4) Press gas safety valve plunger up and hold.
- 5) Push piezo igniter repeatedly until flame is observed at "6".
- 6) When flame is lit:
 - a. Discontinue pushing the piezo plunger.
 - b. BUT continue to hold up on the safety valve plunger for about 15 seconds.
 - c. If flame goes out when plunger is released, repeat Steps 4 through 6.

Turn the handle (8) of the gas valve (7) away from the back of the cabinet to shut off gas operation.

NOTE: The ice tray shelf should now show signs of cooling after an hour. If the gas has to be re-lit when the ice making compartment is still cold, turn the thermostat dial (3) to MAX. Repeat Steps 4 through 6 and, return the thermostat to its normal setting only after the burner is lit.

The refrigerator has a flame failure device which will automatically shut off the gas to the burner if the flame is blown out. While the plunger (4) is being held in, this device is temporarily inoperative.

DANGER - DO NOT hold this plunger in unless attempting to light the gas burner.

B. ELECTRIC OPERATION

- 1) Turn gas valve to "OFF" position (with the handle pointing away from the cabinet).
- 2) Turn voltage selector switch so desired voltage marking is next to the selector position indicator.

For Example:

If 115 volt AC operation is desired, rotate selector to "110-115V" position and connect the 115 volt electrical supply cord.

— or —

If 12 volt DC operation is desired, rotate selector to "12V" position and supply 12 volt battery power.

- 3) Turn the electric thermostat knob to #4 position.

The ice tray shelf should show signs of cooling after about an hour.

TO SHUT OFF ELECTRIC OPERATION:

Rotate the voltage selector switch (2) to the "OFF" position.

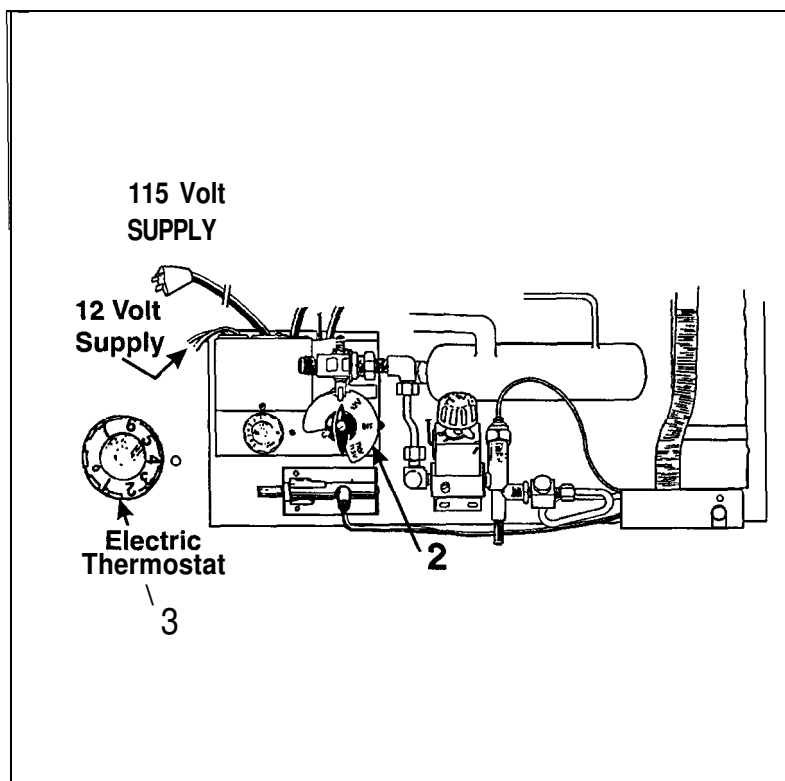

SECTION 2 AC VOLTAGE REQUIREMENTS

The refrigerator is a 120 volt AC, 60 Hz appliance. The proper operating range is 100 to 132 volts. Check the AC volts at the receptacle where the refrigerator is attached. If voltage drops below 100 volts, cooling efficiency will decrease with voltage decrease. If voltage is outside of the proper operating range, correct the power source problem.

SECTION 3 AC COMPONENTS

HEATING ELEMENT

The heating element is designed to deliver a predetermined amount of heat to the cooling unit. To check a heating element, remove the heater leads from the terminal block and measure for proper resistance across the two leads with a properly calibrated ohm meter. This check is to be done with the heating element at room temperature. The proper ohms for the RM2201 AC heating element is 152 with a tolerance range of ten percent. If the resistance is outside the tolerance range, replace the heating element.

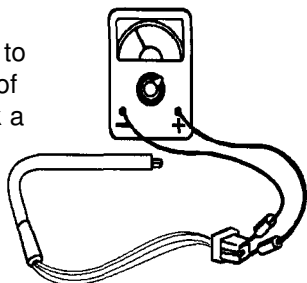

SECTION 4 DC VOLTAGE REQUIREMENTS

For the refrigerator to operate on DC volt operation, DC voltage must be supplied to the terminal block at the rear of the refrigerator. The operational range is 10.5 to 15 volts DC. Connecting the refrigerator to an unregulated converter can result in improper operation of the refrigerator. Check for proper voltage at the terminal block at the back of the refrigerator. If power is outside the operational range, correct the power supply problem. The power supply to the refrigerator must be fused. The DC heating element will draw 7.9 on RM2150, RM2190 and RM2201 at 12 volts. The maximum fuse size is 10 amps for the RM2150, RM2190 and RM2201.

SECTION 5 DC COMPONENTS

5.1 SWITCH

A. TOGGLE SWITCH (RM2150/ RM2190)

The Toggle Switch should be checked for continuity in the following manner:

Remove wires from the assembly.

In the "ON" position, continuity should exist.

In the "OFF" position, no continuity should exist.

If either check is incorrect, the switch is defective and must be replaced.

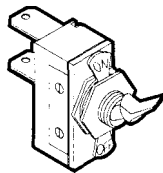

B. SELECTOR SWITCH (RM2201)

The Selector Switch should be checked for continuity in the following manner: Remove all wires from the assembly.

For the DC mode, continuity should exist between terminals 1 and 2 and 5 and 6.

For the AC mode, continuity should exist between terminals 3 and 4 and 7 and 8.

If continuity does NOT exist in any mode when making these checks, the switch is defective and must be replaced.

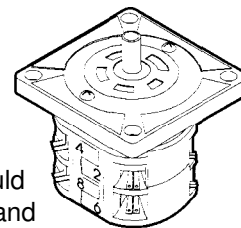

5.2 PIEZO IGNITER

The piezo lighter is a self-contained assembly which generally does not need maintenance. When the button is pushed, a spring loaded striker creates a spark. If there is no resistance when pressing the button, the piezo igniter is defective and must be replaced. If the piezo snaps or has resistance when the button is pushed, but there is no spark, the problem lies in the electrode (see Sec. 5.3).

5.3 ELECTRODE

To check the electrode, first visually inspect it for cracks or breaks on the ceramic insulator. Also, verify the mounting bracket is attached properly to the electrode. If either of the above conditions are found, replace the electrode. Next, check the spark gap. It must be set at three sixteenths (3/16) of an inch and the tip of electrode above the slots in the burner.

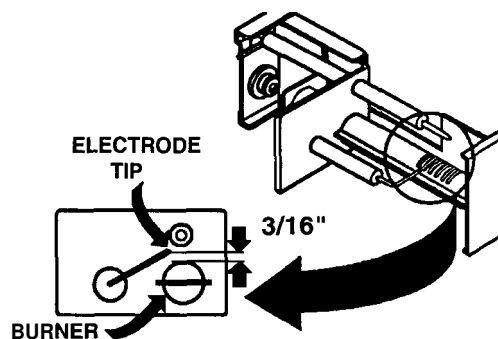

NOTE: If piezo igniter (See Sec. 5.2) is good and there is no spark at the tip of the electrode, REPLACE THE ELECTRODE.

5.4 HEATING ELEMENT

The heating element is designed to deliver a predetermined amount of heat to the cooling unit. Check the heating element with ohms resistance using a properly calibrated ohm meter. This check is to be done with the element at room temperature. The proper ohms for RM2150, RM2190 and RM2201 is .66 with a tolerance range of (10) percent. If the heating element is outside the tolerance range, replace it.

NOTE: It will take a very precise ohm meter to accurately read this measurement. If a precise ohm meter is not available, a continuity reading will indicate an open or complete circuit. If an open circuit is the test result, replace the element.

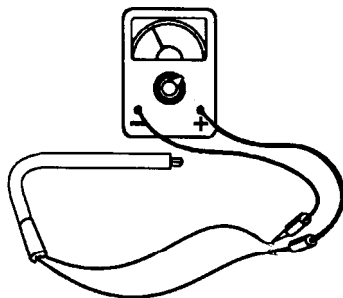

5.5 THERMOSTAT (RM2201)

The thermostat regulates the cabinet temperature by making and breaking the heat source circuit. The internal mechanism breaks contact (continuity) when adequate cabinet temperature has been reached. Check the thermostat for continuity or use a jumper wire with insulated clips and bypass the thermostat.

NOTE: Care should be used. Do not short to thermostat casing. Also, remove the jumper after testing is completed.

If the above test allows the refrigerator to operate, replace the thermostat.

SECTION 7 LP GAS COMPONENTS

7.1 SHUT-OFF VALVE

This is the valve where the incoming LP gas supply is attached. To check the shut-off valve, remove and inspect for any obstructions.

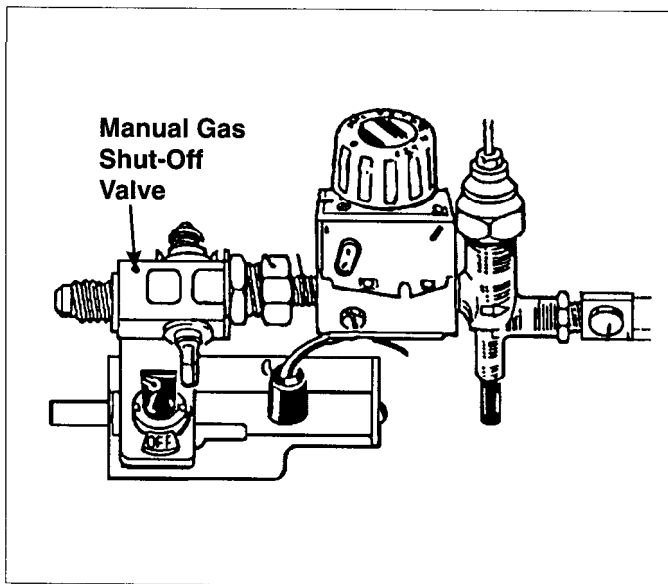

SECTION 6 LP GAS REQUIREMENTS

The LP gas pressure to the refrigerator should be 11 inches water column with half of all BTU's of the RV turned on. With all other appliances turned off, the pressure to the refrigerator should not exceed 12 inches water column. To check the gas pressure when the refrigerator is operating, there is a pressure test housing located just prior to the orifice.

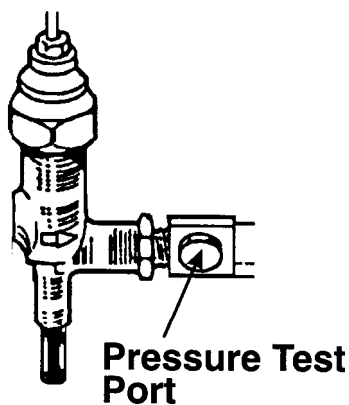
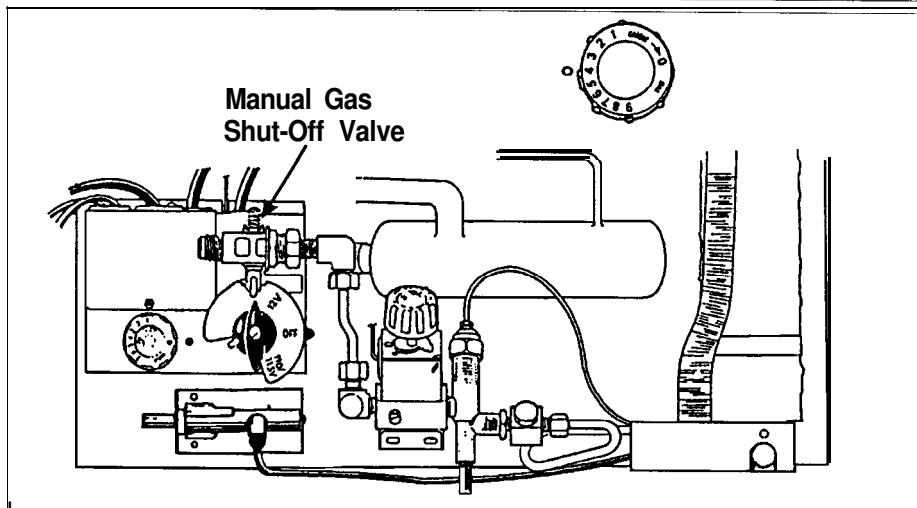

7.2 FILTER

A filter is located in the inlet fitting to the thermostat. It protects the internal valve portion of the thermostat by collecting any particles and/or oil that could get into the LP gas line. The filter can become saturated and cause a restriction to gas flow. This could cause a lack of cooling on gas mode. If you suspect a restriction, first verify the thermostat (See Sec. 7.3) is good. If the thermostat is good, and filter is restricted, replace thermostat.

7.3 THERMOSTAT

On the LP gas mode, full line pressure is directed through the thermostat to the burner until the thermostat senses that the refrigerator cabinet has reached proper cooling temperature. At that time an internal valve closes and redirects the gas flow through the bypass screw. This reduces the amount of LP gas going to the burner assembly. The gas flow remains in this "bypass" mode until the thermostat senses that the refrigerator cabinet needs more cooling. Again, the thermostat directs LP gas flow through the thermostat at full line pressure until the cabinet temperature is sufficient. The thermostat is calibrated by the manufacturer so that at mid-range the cabinet temperature should be approximately 40 degrees Fahrenheit. **To check the calibration of the thermostat**, place a container of water in the cabinet of the refrigerator and operate at mid-range setting until the thermostat is satisfied. Then, check the temperature of the water. It should be approximately 40 degrees. We do not recommend any calibration in the field. If calibration is not correct, replace the thermostat. **To check the thermostat for proper gas flow, set** the thermostat to maximum and check the gas pressure at the pressure test port. It should be line pressure, between 11 to 12 inches water column. If you have less than 11 inches of water column pressure, the next step would be to shut off the gas supply and remove the bypass screw. Then install a bypass screw that does not have the small o-ring on it. Next, turn on the gas supply and take a reading. If the manometer now reads 11 inches of water column, the thermostat is defective and must be replaced. If the bypass screw test shows no change in pressure, the problem lies in the filter (See Sec. 7.2) the shut-off valve (See Sec. 7.1) or the gas supply (See Sec. 6). Shut off the gas supply, remove the bypass screw, replace it with the original one that has an o-ring and turn the gas on.

NOTE: Check for leaks with an approved LP gas leak solution whenever any part of the gas system has been worked on or the system has been separated.

7.4 SAFETY VALVE

The safety valve is an assembly that shuts off the supply of LP gas to the burner if the flame goes out for any reason. This is to ensure that a concentration of unburned gas does not accumulate in the refrigerator vent area. To check the safety valve, use a known good thermocouple (see SEC. 7.5) and install into the safety valve. Next, supply flame to the tip of the thermocouple for 2 to 3 minutes while holding in on the safety valve stem. Next, remove flame from thermocouple tip and release safety valve stem. The safety valve should hold in for at least 30 seconds. If it releases earlier than 30 seconds, replace the safety valve.

7.5 THERMOCOUPLE

The thermocouple is a component extending above the burner assembly so the tip is in the path of the flame. It will produce 14 to 30 millivolts DC in normal operation. To check the thermocouple, use a known good safety valve (See Sec. 7.4) and attach to the thermocouple. Next, supply flame to the tip of the thermocouple for 2 to 3 minutes while depressing the safety valve. Remove the flame and release the safety valve. The valve should hold for at least 30 seconds. If it does not hold the safety valve open for 30 seconds, replace the thermocouple. If it does hold for 30 seconds or more, the thermocouple is good, do not replace it.

NOTE: Be sure the tip on the thermocouple is clean.

7.6 BURNER

The burner is a slotted metal tube located below the flue tube on the cooling unit. It should be level and the slots, in the burner, should be directly below the flue tube. The burner should be cleaned periodically, at least once a year. To clean the burner, remove from the refrigerator and check for any foreign residue that could cause a deflection of the gas flow or the flame. Next, soak the burner in an alcohol based solvent and allow to air dry. After cleaning, reinstall in the refrigerator.

7.7 FLUE BAFFLE

The flue baffle is designed to concentrate the heat from the gas flame and direct it to a certain area of the flue tube. It should be cleaned periodically, at least once a year. To clean, remove from the flue tube and check for any damage, then clean thoroughly.

The length of the flue baffle assembly (flue baffle and wire) on the RM2150 and RM2190 is 13-1/8"; On the RM2201 it is 13-3/4". The flue baffle itself should measure 3-15/16" long and 9/16" wide on the RM2150, RM2190 and RM2201. The proper position of the baffle above the burner is 3-1/2" on RM2150 and RM2190; and 3-3/8" on the RM2201.

7.8 CROSSOVER TUBE

The crossover tube is located at the top of the flue tube and is attached with a screw. It must be properly attached or flame outage could occur. If the balanced flue tube is too close to the opening of the crossover tube, it can also cause flame outage or difficulty in lighting.

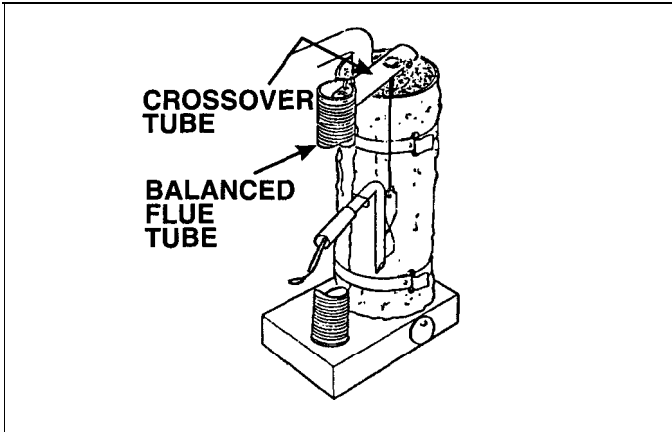

7.9 FLUE TUBE

The flue tube is a component of the cooling unit. It must be cleaned periodically, at least once a year. To clean, remove crossover tube and flue baffle, then cover the burner and clean by using a flue brush. If the flue tube becomes coated with scale or residue from combustion of LP gas, the efficiency of gas operation decreases.

NOTE: After cleaning be sure to reinstall the flue baffle and crossover tube.

7.10 ORIFICE

The orifice is a small brass fitting that has a ruby membrane that is laser beam drilled and is mounted on the gas line just prior to the burner. The orifice should be cleaned periodically, at least once a year, by using an alcohol based solvent and allowing to air dry. Never use a drill bit or jet tip cleaner to clean any orifice as these devices will damage the factory machined part and create a potentially dangerous condition. The correct orifice for the RM2150, RM2190 and RM2201 is Size F. NOTE: Always use the proper orifice. Never use a larger orifice as this could cause a lack of cooling problem.

SECTION 8 WIRING

8.1 EXTERNAL WIRING

A. **120 Volts AC Connection (RM2201):** The refrigerator is equipped with a three prong (grounded) plug for protection against shock hazards and should be plugged directly into a properly grounded three prong receptacle. DO NOT cut or remove the grounding prong from this plug.

B. **12 Volt DC Connection for Heater:** This connection is made to the terminal block. The refrigerator must be connected to the battery circuit with two wires of adequate capacity to avoid voltage drop. The wire gauge should be 14 AWG.

Do not use the body or chassis of the vehicle as a substitute for either of the two conductors. No other electrical equipment or lighting should be connected to the refrigerator circuit.

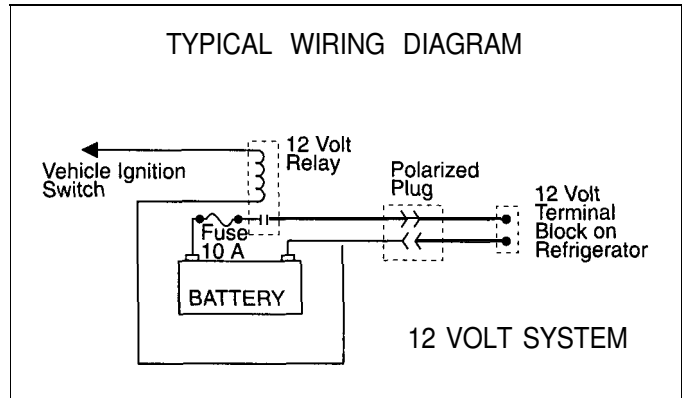

8.2 INTERNAL WIRING

Check all wires and the connectors to ensure a proper and tight connection. Also verify the refrigerator is wired per the wiring diagram for the model you are working on.

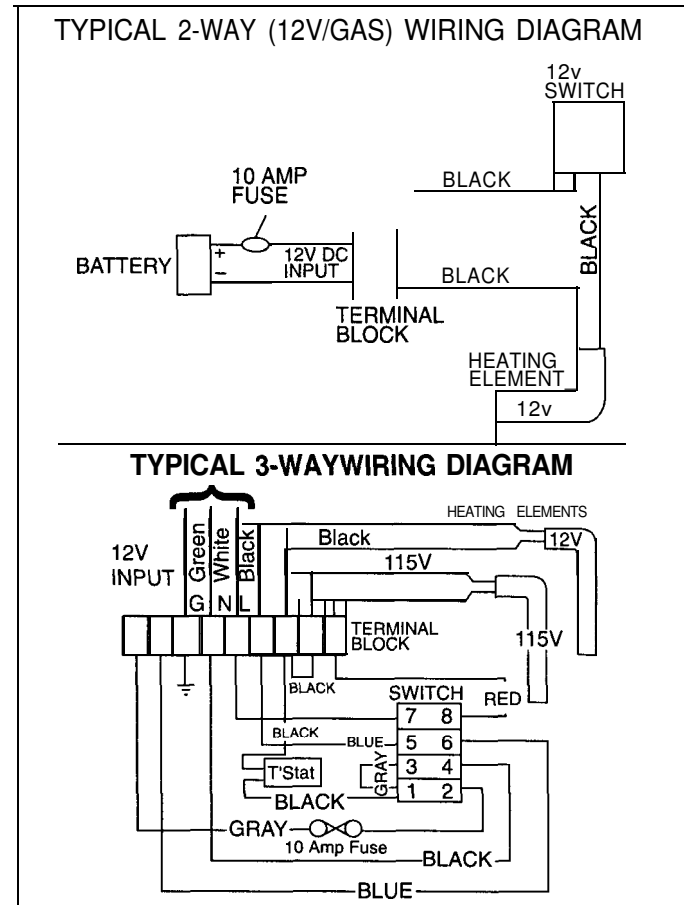

**SECTION 9
OTHER**

9.1 LEVELING

Leveling is one of the requirements for proper operation with absorption refrigerators. The absorption design utilizes no mechanical pumps or compressors to circulate the refrigerant within the system, so proper leveling must be maintained to provide the correct refrigerant flow. Without proper leveling, refrigerant within the cooling unit will collect and stagnate at certain areas. Without proper refrigerant flow, the cooling process will stop. The RM2150, RM2190 and RM2201 Refrigerators have a type of cooling unit that utilizes an enclosed pump tube surrounded by a solution to protect the assembly. To ensure proper leveling with these models, the vehicle needs to be leveled so it is comfortable to live in. (No noticeable sloping of floor or walls). When the vehicle is moving, leveling is not critical as the rolling and pitching movement of the vehicle will pass to either side of level, keeping the refrigerant from accumulating in the piping.

9.2 VENTILATION

Ventilation is one of the requirements for proper cooling unit operation. The coach vent system must be able to provide a way to direct the hot air, produced by the action of the cooling unit, out away from the installation of the refrigerator. The refrigerator extracts heat from the interior of the refrigerator cabinet and dissipates the heat out through the vent system. In a proper installation there

should be zero (0") clearance surrounding the sides and top of the refrigerator to achieve proper air flow. All potential dead air pockets should be blocked or baffled to ensure that heat won't be trapped in these spaces and reduce efficiency. In addition, the cooling unit should be at least one inch (1") from the nearest surface made of combustible material.

NOTE: Refrigerators should be installed in accordance with appropriate installation instructions received with the refrigerator.

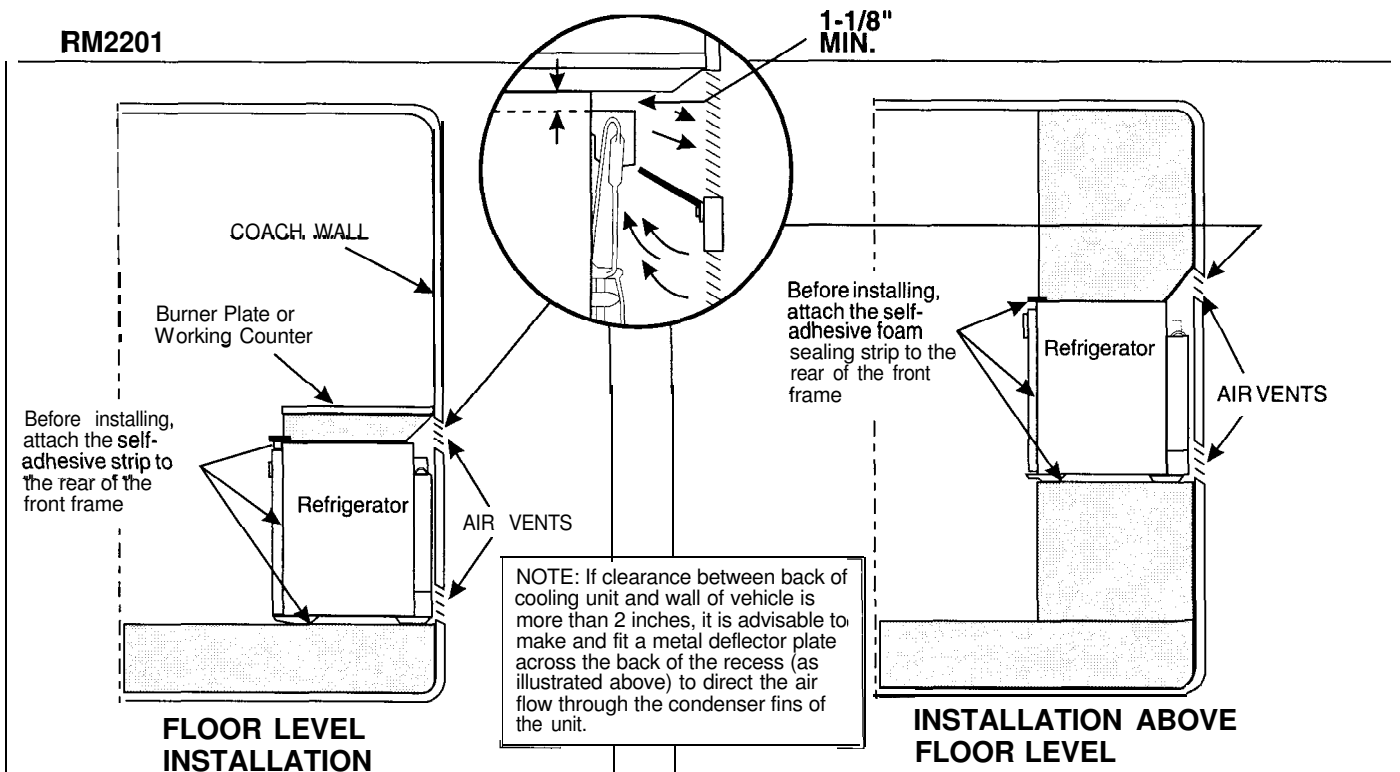
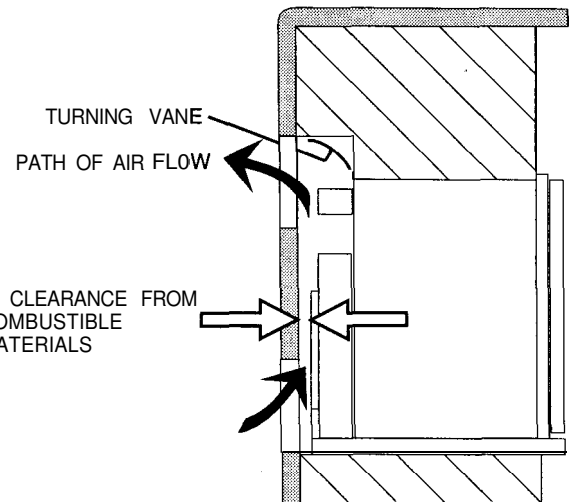

9.3 AIR LEAKS

Check the gasket on the doors to be sure of a positive air seal. A simple method to check gaskets is to close the door on a dollar bill, then pull the dollar bill out. If no resistance is felt, the gasket is not sealing properly. This should be done on all four sides of the door. If a gasket is not sealing properly, first warm the gasket material with a hair dryer.

! CAUTION
DO NOT OVERHEAT
AS YOU CAN MELT THE MATERIAL.

Then close the door and the magnetic strip should pull the gasket to the metal frame. Leave door closed until the material has cooled. Then recheck for a positive seal. If a positive seal cannot be achieved, replace the door gasket. Also check that the cooling unit is installed properly. The cooling unit's foam block, the portion that surrounds the evaporator coils, must be flush to the cabinet at the back of the refrigerator and have a positive seal. If the cooling unit is not installed properly, remove and install properly.

NOTE: Air leaks will cause insufficient cooling as well as rapid formation of frost.

9.4 DOOR POSITION

The door position can be checked by observing any misalignment of the door in relation to the frame.

To correct an alignment of the door, loosen the hinge screws slightly, and reorient the door in the proper position. Hold the door in its new position and carefully retighten the hinge screws.

If the door needs more adjustment than is available through the hinge adjustment, the base can be repositioned to reorient the door. Turn the refrigerator on its side to gain access to the two front base screws. Loosen both screws slightly. Reposition the base until the door is reoriented. Retighten the base screws while holding the base in its new position.

9.5 AMBIENT TEMPERATURE

This is the temperature surrounding the recreational vehicle, as well as the temperature of air at the back of the refrigerator. As the ambient temperature increases, the air temperature in the area of the cooling unit increases. Improper venting at this point, will cause the cooling unit to have reduced efficiency.

9.6 COOLING UNIT

The cooling unit is a self-contained, hermetically sealed set of coils where the refrigeration process takes place. The chemicals involved in the cooling process include hydrogen, ammonia, water and a rust inhibiting agent. There are no repairs recommended on the cooling unit.

If it is defective, replace with a new cooling unit. To check the cooling unit, first verify the heating element is good. Then place approximately one-half gallon of water inside the refrigerator and place a thermometer in one of the containers of water. Next, supply volts direct to the heating element and operate for at least 12 hours. Then check the temperature on the thermometer. It should be at 45 degrees or lower depending on test conditions (See ambient temperature Sec. 9.5). If so, the cooling unit is good. If the temperature of the water is above 45 degrees, replace the cooling unit.

9.7 FOOD STORAGE

Proper refrigeration requires free air circulation within the food storage compartment. Restricted air circulation within this compartment will cause higher cabinet temperatures. To remedy this situation, simply rearrange your foodstuffs. It is also essential that the shelves are not covered with paper or large storage containers. Always remember to allow for proper air circulation. Odorous or highly flavored foods should always be stored in covered dishes, plastic bags or wrapped in foil or waxed paper to prevent food odors. Vegetables, lettuce, etc., should be covered to retain their crispness. NEVER PUT HOT FOOD INTO THE REFRIGERATOR. To reduce frost formation, cover stored liquids and moist foods and do not leave the door open longer than necessary. When the refrigerator is heavily loaded, it takes a longer time for refrigerator temperatures to lower. A very heavy load may also cause defrosting.

9.8 HIGH HUMIDITY

High humidity may cause a small amount of condensation to form on the frame of the refrigerator. In some cases it can develop to such a degree that it will run off the frame. As the humidity is reduced, the sweating will decrease. High humidity can also be a factor in rapid formation of frost.

9.9 INTERIOR LINER SEAL TO FRAME

There is a seal that is applied to the liner in the area where the metal frame makes contact with the interior liner. If this seal is incomplete, cold air can migrate out to the metal frame. If this happens, condensation could form on the frame and could promote rapid formation of frost. If you suspect an improper seal, apply a small bead of silicone all the way around the perimeter where the frame meets the interior liner.

Manual provided courtesy
Bryant RV Services
www.byantrv.com

All manuals are believed to be released for distribution, and/or in the public domain.

Service manuals provided with the understanding that persons using them are well versed in proper safety practices, and are familiar with basic safety procedures, including, but not limited to safety procedures dealing with 120 volt electricity, high amperage 12 volt circuits an LPG (propane) systems.

If in doubt, consult a professional (better safe than sorry).