



RECORD THIS UNIT INFORMATION FOR  
 FUTURE REFERENCE:  
 Model Number \_\_\_\_\_  
 Serial Number \_\_\_\_\_  
 Date Purchased \_\_\_\_\_

**579 Series BRISK AIR  
 590 Series QUICK COOL  
 595 Series QUICK COOL  
 Roof Top Air Conditioner**

**USED WITH  
 Part No. 3107206  
 Air Distribution Box Kit  
 Mechanical**

**PRE-WIRED FOR OPTIONAL HEAT PACKAGE**



**USA**  
 SERVICE OFFICE  
 Dometic Corp.  
 509 So. Poplar St.  
 LaGrange, IN 46761  
 (260) 463-4858

**CANADA**  
 Dometic Dist.  
 866 Langs Dr.  
 Cambridge, Ontario  
 CANADA N3H 2N7  
 (519) 653-4390

**For Service Center  
 Assistance Call:**  
 800-544-4881

**⚠ WARNING**

This manual must be read and understood before installation, adjustment, service, or maintenance is performed. This unit must be installed by a qualified service technician. Modification of this product can be extremely hazardous and could result in personal injury or property damage.

**⚠ AVERTISSEMENT**

Lire et comprendre ce manuel avant de procéder à l'installation, à des réglages, de l'entretien ou des réparations. L'installation de cet appareil doit être effectuée par un réparateur qualifié. Toute modification de cet appareil peut être extrêmement dangereuse et entraîner des blessures ou dommages matériels.

**INSTALLATION & OPERATING  
 INSTRUCTIONS**

**MODELS**

57908.521	57915.422	57915.621	59516.501
57912.621	57915.521	57915.622	59516.531
57912.622	57915.522	57915.631	59516.536
57912.631	57915.531	59016.521	59516.601
57915.322	57915.536	59016.621	59516.603
57915.331	57915.541	59516.303	59516.631
57915.421	57915.546	59516.331	

**REVISION:**  
 Form No. 3107195.095 11/03  
 (Replaces 3107195.087)  
 (French 3108172.052)  
 ©2003 Dometic Corporation  
 LaGrange, IN 46761

**Important: These instructions must stay with  
 unit. Owner read carefully.**

## SAFETY INSTRUCTIONS

This manual has safety information and instructions to help users eliminate or reduce the risk of accidents and injuries.

### RECOGNIZE SAFETY INFORMATION



This is the safety-alert symbol. When you see this symbol in this manual, be alert to the potential for personal injury.

Follow recommended precautions and safe operating instructions.

### UNDERSTAND SIGNAL WORDS

A signal word, **WARNING OR CAUTION** is used with the safety-alert symbol. They give the level of risk for potential injury.

**WARNING** indicates a potentially hazardous situation which, if not avoided, could result in death or serious injury.

**CAUTION** indicates a potentially hazardous situation which, if not avoided may result in minor or moderate injury.

**CAUTION** used without the safety alert symbol indicates, a potentially hazardous situation which, if not avoided may result in property damage.

Read and follow all safety information and instructions.

## GENERAL INFORMATION

**A.** This air conditioner is designed for:

1. Installation on a recreational vehicle during or after the time the vehicle is manufactured.
2. Mounting on the roof of a recreational vehicle.
3. Roof construction with rafters/joists on minimum of 16 inch centers.
4. Minimum of 1.00 inches and maximum of 4 inches distance between roof to ceiling of recreational vehicle. Alternate installation methods will allow for roofs more than 4 inches thick.

**B.** The ability of the air conditioner to maintain the desired inside temperature depends on the heat gain of the RV. Some preventative measures taken by the occupants of the RV can reduce the heat gain and improve the performance of the air conditioner. During extremely high outdoor temperatures, the heat gain of the vehicle may be reduced by:

1. Parking the RV in a shaded area
2. Using window shades (blinds and/or curtains)
3. Keeping windows and doors shut or minimizing usage
4. Avoiding the use of heat producing appliances

Operation on High Fan/Cooling mode will give optimum or maximum efficiency in high humidity or high outside temperature.

Starting the air conditioner early in the morning and giving it a "head start" on the expected high outdoor ambient will greatly improve its ability to maintain the desired indoor temperature.

For a more permanent solution to a high heat gain, accessories like A&E outdoor patio and window awnings will reduce heat gain by removing the direct exposure to the sun. They also add a nice area to enjoy company during the cool of the evening.

**C.** Condensation

**Note:** The manufacturer of this air conditioner will not be responsible for damage caused by condensed moisture on ceilings or other surfaces. Air contains moisture and this moisture tends to condense on cold surfaces. When air enters the RV, condensed moisture may appear on the ceiling, windows, metal parts, etc. The air conditioner removes this moisture from the air during normal operation. Keeping doors and windows closed when this air conditioner is in operation will minimize condensed moisture on cold surfaces.

# INSTALLATION AND OPERATING INSTRUCTIONS

## SPECIFICATIONS

MODEL NO.	NOMINAL CAPACITY (BTU/HR) COOLING	ELECTRICAL RATING	COMPRESSOR RATED LOAD AMPS	COMPRESSOR LOCKED ROTOR AMPS	FAN MOTOR RATED LOAD AMPS	FAN MOTOR LOCKED ROTOR AMPS	SCFM-HIGH SPEED MAX/MIN	TOTAL STATIC MAX/MIN "W. C.	REFRIGERANT R-22 (OZ)	MINIMUM WIRE SIZE*	AC CIRCUIT PROTECTION ***USER SUPPLIED	INSTALLED WEIGHT (POUNDS)	MINIMUM GENERATOR SIZE** 1 UNIT/2 UNITS
57908.321	7,180	115VAC, 60 HZ., 1PH.	6.9	36.0	2.5	5.8	325/250	0.55/0.90	16.0	12 AWG Copper up to 24'	20 Amp	75	2.5 KW / 4.0 KW
57908.521	7,100		6.6	34.0	2.5	5.8	325/250	0.55/0.90	17.0		20 Amp	75	2.5 KW / 4.0 KW
57912.321	11,000		9.5	53.0	2.5	5.8	325/250	0.55/0.90	15.5		20 Amp	94	2.5 KW / 4.0 KW
57912.531	11,000		8.0	53.0	2.5	5.8	325/250	0.55/0.90	18.5		20 Amp	94	2.5 KW / 4.0 KW
57912.621	11,000		8.5	48.3	2.5	5.8	325/250	0.55/0.90	16.0		20 Amp	94	2.5 KW / 4.0 KW
57912.622	11,000		8.5	48.3	2.5	5.8	325/250	0.55/0.90	18.0		20 Amp	94	2.5 KW / 4.0 KW
57912.631	11,000		8.5	48.3	2.5	5.8	325/250	0.55/0.90	18.0		20 Amp	94	2.5 KW / 4.0 KW
57915.322	13,500		11.4	58.0	2.5	5.8	325/250	0.55/0.90	15.5		20 Amp	100	3.5 KW / 5.0 KW
57915.331	13,500		11.4	58.0	2.5	5.8	325/250	0.55/0.90	15.5		20 Amp	100	3.5 KW / 5.0 KW
57915.336	13,500		12.1	59.0	2.5	5.8	325/250	0.55/0.90	16.5		20 Amp	100	3.5 KW / 5.0 KW
57915.421	13,500		11.5	50.0	2.5	5.8	325/250	0.55/0.90	13.5		20 Amp	100	3.5 KW / 5.0 KW
57915.422	13,500		11.5	50.0	2.5	5.8	325/250	0.55/0.90	14.5		20 Amp	100	3.5 KW / 5.0 KW
57915.426	13,500		11.5	50.0	2.5	5.8	325/250	0.55/0.90	13.5		20 Amp	100	3.5 KW / 5.0 KW
57915.521	13,500		12.1	59.0	2.5	5.8	325/250	0.55/0.90	16.0		20 Amp	94	3.5 KW / 5.0 KW
57915.522	13,500		12.1	59.0	2.5	5.8	325/250	0.55/0.90	16.5		20 Amp	94	3.5 KW / 5.0 KW
57915.526	13,500		12.1	59.0	2.5	5.8	325/250	0.55/0.90	16.0		20 Amp	94	3.5 KW / 5.0 KW
57915.531	13,500		12.1	59.0	2.5	5.8	325/250	0.55/0.90	16.5		20 Amp	94	3.5 KW / 5.0 KW
57915.536	13,500		12.1	59.0	2.5	5.8	325/250	0.55/0.90	16.5		20 Amp	94	3.5 KW / 5.0 KW
57915.541	13,500		11.3	62.0	2.5	5.8	325/250	0.55/0.90	16.0		20 Amp	94	3.5 KW / 5.0 KW
57915.546	13,500		11.3	62.0	2.5	5.8	325/250	0.55/0.90	16.0		20 Amp	94	3.5 KW / 5.0 KW
57915.621	13,500		11.0	54.4	2.5	5.8	325/250	0.55/0.90	16.0		20 Amp	94	3.5 KW / 5.0 KW
57915.622	13,500		11.0	54.4	2.5	5.8	325/250	0.55/0.90	16.5		20 Amp	94	3.5 KW / 5.0 KW
57915.626	13,500		11.0	54.4	2.5	5.8	325/250	0.55/0.90	16.0		20 Amp	94	3.5 KW / 5.0 KW
57915.631	13,500		11.0	54.4	2.5	5.8	325/250	0.55/0.90	16.5		20 Amp	94	3.5 KW / 5.0 KW
57915.731	13,500		11.3	56.0	2.5	5.8	325/250	0.55/0.90	15.0		20 Amp	94	3.5 KW / 5.0 KW
59016.521	15,000		12.9	71.0	2.5	6.0	350/250	0.40/1.10	26.5		20 Amp	101	3.5 KW / 5.0 KW
59516.303	15,000		12.7	60.0	2.0	5.6	350/250	0.40/1.10	29.0		20 Amp	94	3.5 KW / 5.0 KW
59016.621	15,000		12.9	77.0	2.5	6.0	350/250	0.40/1.10	26.5		20 Amp	101	3.5 KW / 5.0 KW
59516.331	15,000		11.5	50.0	2.5	5.8	325/250	0.40/1.10	29.0		20 Amp	94	3.5 KW / 5.0 KW
59516.336	15,000		12.7	60.0	2.0	5.6	325/250	0.40/1.10	29.0		20 Amp	94	3.5 KW / 5.0 KW
59516.501	15,000		11.5	50.0	2.5	5.8	325/250	0.40/1.10	31.0		20 Amp	94	3.5 KW / 5.0 KW
59516.531	15,000		11.5	50.0	2.5	5.8	325/250	0.40/1.10	26.5		20 Amp	94	3.5 KW / 5.0 KW
59516.536	15,000		11.5	50.0	2.5	5.8	325/250	0.40/1.10	29		20 Amp	94	3.5 KW / 5.0 KW
59516.601	15,000		12.9	77.0	2.5	6.0	350/250	0.40/1.10	31.0		20 Amp	102	3.5 KW / 5.0 KW
59516.603	15,000		12.3	77.0	2.0	5.6	325/250	0.40/1.10	29.5		20 Amp	102	3.5 KW / 5.0 KW
59516.606	15,000		12.9	71.0	2.0	6.0	325/250	0.40/1.10	31.0		20 Amp	102	3.5 KW / 5.0 KW

\* For wire lengths over 24 ft. consult the National Electric Code for proper sizing.

\*\* Dometic Corporation gives **GENERAL** guidelines for generator requirements. These guidelines come from experiences people have had in actual applications. When sizing the generator, the total power usage of your recreational vehicle must be considered. Keep in mind generators lose power at high altitudes and from lack of maintenance.

\*\*\* CIRCUIT PROTECTION: Time Delay Fuse or HACR Circuit Breakers Required.

# INSTALLATION INSTRUCTIONS

## 1. PRECAUTIONS

### ⚠ WARNING

Improper installation may damage equipment, could endanger life, cause serious injury and/or property damage.

- A. Read installation and operating instructions carefully before attempting to start your air conditioner installation.
- B. The Dometic Corporation will not be liable for any damages or injury incurred due to failure in following these instructions.
- C. Installation **must** comply with the National Electrical Code and any State or Local Codes or regulations.
- D. **DO NOT** add any devices or accessories to this air conditioner except those specifically authorized by Dometic.
- E. This equipment must be serviced by qualified personnel and some states require these people to be licensed.

## 2. CHOOSING LOCATION FOR THE AIR CONDITIONER

This air conditioner is specifically designed for installation on the roof of a recreational vehicle (RV).

### CAUTION

It is the responsibility of the installer of this air conditioner/heat pump system to ensure structural integrity of the RV roof. Never create a low spot on the roof where water will collect. Water standing around the air conditioner/heat pump may leak into the interior causing damage to the product and the RV.

#### A. NORMAL LOCATIONS:

The air conditioner is designed to fit over an existing roof vent opening. When the vent is removed, it normally creates a 14-1/4" x 14-1/4" ±1/8 opening.

#### B. OTHER LOCATIONS:

When no roof vent is available or another location is desired, the following is recommended:

- a. For one unit installation: The air conditioner should be mounted slightly forward of center (front to back) and centered from side to side. See FIG. 1.

FIG. 1

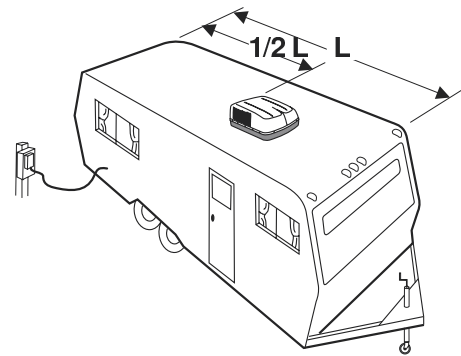

- b. For two unit installations: Install one air conditioner 1/3 and one air conditioner 2/3's from front of RV and centered from side to side. See FIG. 2.

FIG. 2

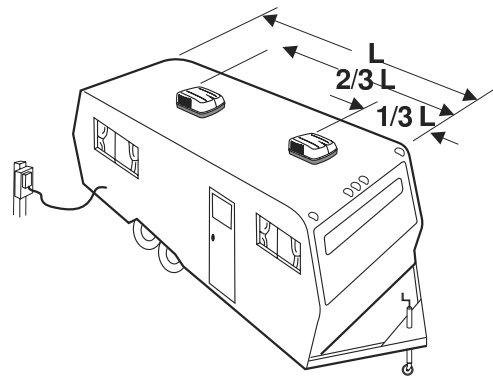

It is preferred that this air conditioner be installed in a relatively flat and level roof section measured with the RV parked on a level surface; however, up to 15° slant to either side, or front-to-back, is acceptable.

#### C. AFTER LOCATION SELECTION:

- a. Check for obstructions in the area where air conditioner will be installed.
- b. The roof must be designed to support 130 pounds when the RV is in motion. Normally a 200 lb. static load design will meet this requirement.
- c. Check inside the RV for air box obstructions. (i.e. door openings, room dividers, curtains, ceiling fixtures, etc.) See FIG. 3.

# INSTALLATION AND OPERATING INSTRUCTIONS

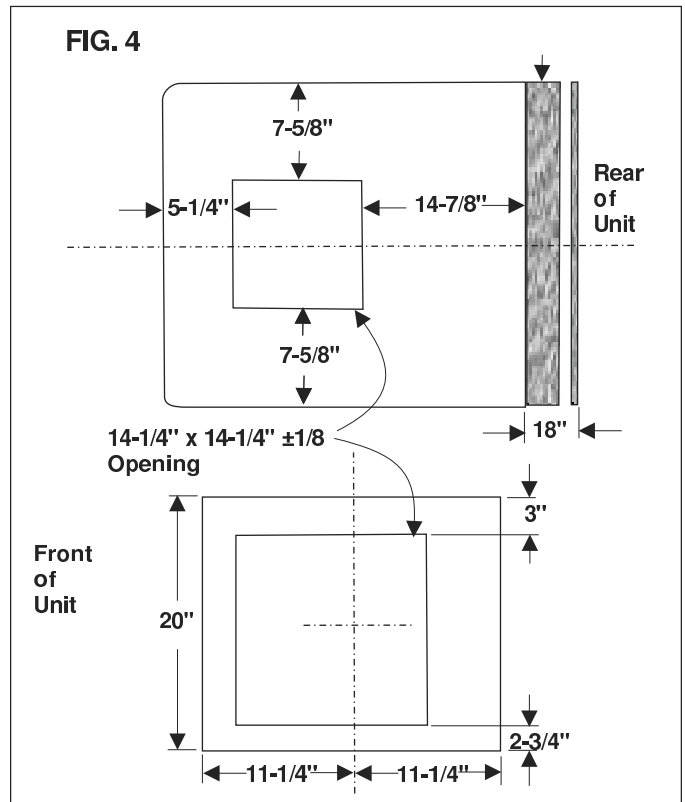
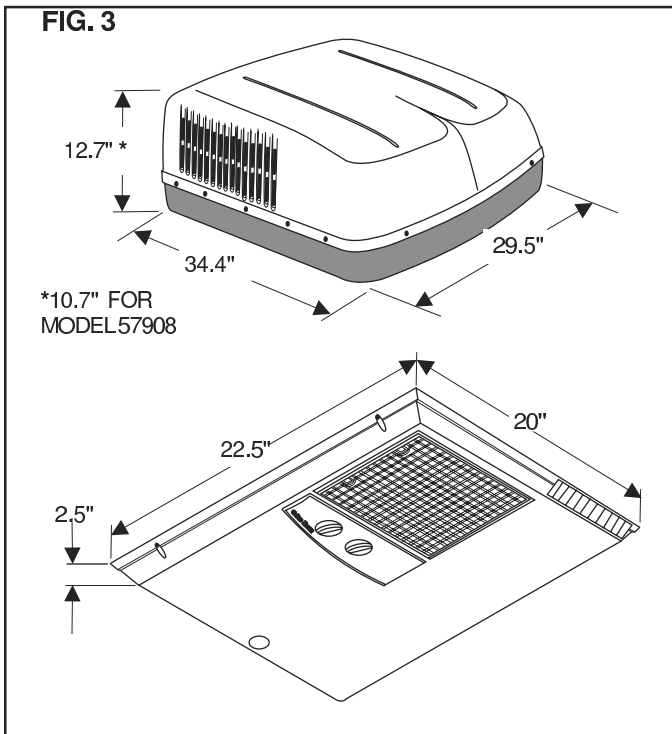

## 3. ROOF PREPARATION

### A. ROOF VENT REMOVAL:

1. Unscrew and remove the roof vent.
2. Remove all caulking compound around opening.
3. Seal all screw holes and seams where the roof gasket will be located. Use a good grade of all weather sealer.

### B. NEW OPENING:

(Installations Other Than Vent Openings)

### **! WARNING**

**There may be electrical wiring between the roof and the ceiling. Disconnect 115 volt AC power cord and the positive (+) 12 volt DC terminal at the supply battery. Failure to follow this instruction may create a shock hazard causing death or severe personal injury.**

1. A 14-1/4" x 14-1/4"±1/8 opening must be cut through the roof and ceiling of the RV. It is recommended this opening be located between roof reinforcing members.
2. Mark a 14-1/4" x 14-1/4"±1/8 square on the roof and carefully cut the opening.
3. Using the roof opening as a guide, cut the matching hole in the ceiling. See FIG.4.

### C. OPENING PREPARATION:

1. If the opening exceeds 14-3/8" x 14-3/8", it will be necessary to install spacers.
2. If the opening is less than 14-1/8" x 14-1/8", it must be enlarged.

3.

Route a copper 12 AWG, with ground, supply line from the fuse or circuit breaker box to the roof opening.

- a. The power supply must be on a separate 20 amp Time Delay Fuse or HACR Circuit Breaker.
- b. Wiring must comply with all National, State and Local wiring codes.
- c. Make sure at least 15" of wire extend into the roof opening. This insures easy air conditioner attachment.
- d. If vent fan was removed, the existing wire may be used provided it is of proper size and correctly fused.

### **CAUTION**

**It is the responsibility of the installer of this air conditioner system to ensure structural integrity of the RV roof. Never create a low spot on the roof where water will collect. Water standing around the air conditioner may leak into the interior causing damage to the product and the RV.**

4.

The opening must be framed to provide adequate support and prevent air from being drawn from the roof cavity. Lumber 3/4" thick or more and long enough to bridge the opening must be used. Remember to provide and entrance hole for the power supply wire. See FIG. 5.

# INSTALLATION AND OPERATING INSTRUCTIONS

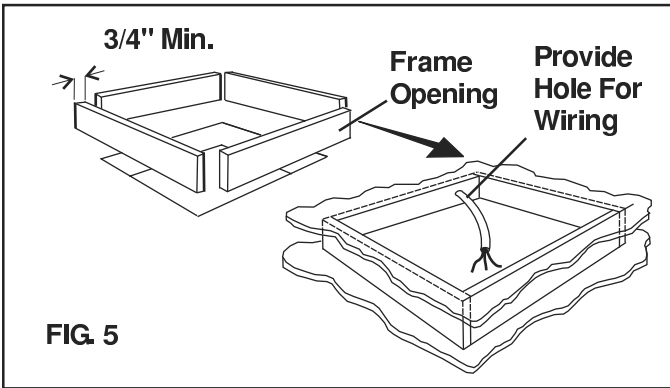

FIG. 5

5. The 14-1/4" x 14-1/4" ± 1/8" roof opening is part of the return air duct and must be finished in accordance with NFPA standard 501C, Standard for Recreational Vehicles, Section 2-7.

## 4. PLACING THE AIR CONDITIONER ON THE ROOF

- A. Remove the Air Conditioner from the carton and discard the carton.

### CAUTION

This unit weighs approximately 100 pounds. To prevent back injury, use a mechanical hoist to place air conditioner on roof.

- B. Place the air conditioner on the roof.
- C. Lift and place the unit over the prepared opening using the gasket as a guide. The condenser coil goes toward the rear of the RV. See FIG. 6.

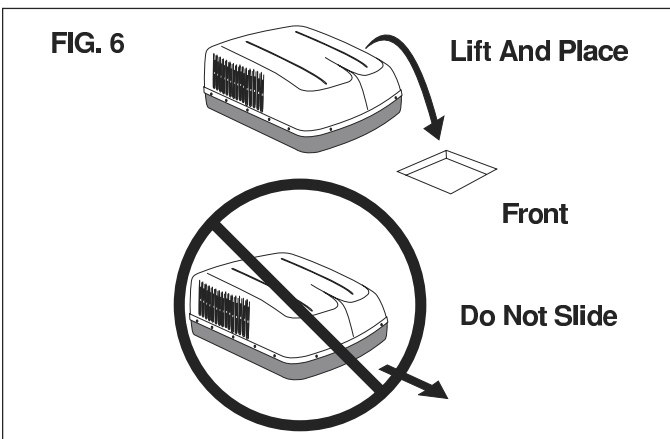

FIG. 6

### CAUTION

Do not slide the unit. This may damage the neoprene gasket attached to the bottom and create a leaky installation.

- D. Place the 3107206 Air Box Kit inside the RV. This box contains mounting hardware for the air conditioner and will be used inside the RV. See FIG. 7.

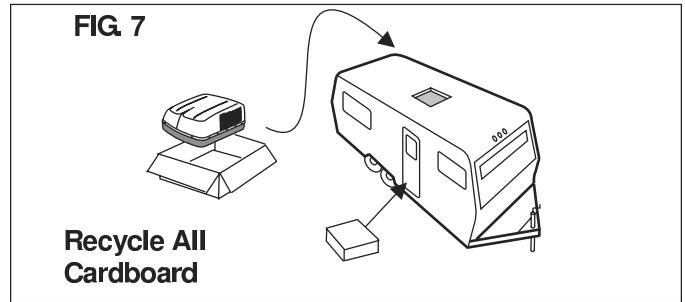

FIG. 7

Recycle All Cardboard

This completes the outside work. Minor adjustments can be done from the inside if required.

## 5. DISCHARGE DUCT AND CEILING TEMPLATE INSTALLATION

- A. Remove air box and mounting hardware from carton. The upper duct is shipped inside the lower duct which is part of the ceiling template.
  1. Remove upper duct from ceiling template and locate it over blower discharge.

**Note:** Edges without flanges install toward REAR and SIDE of opening. See FIG. 8.

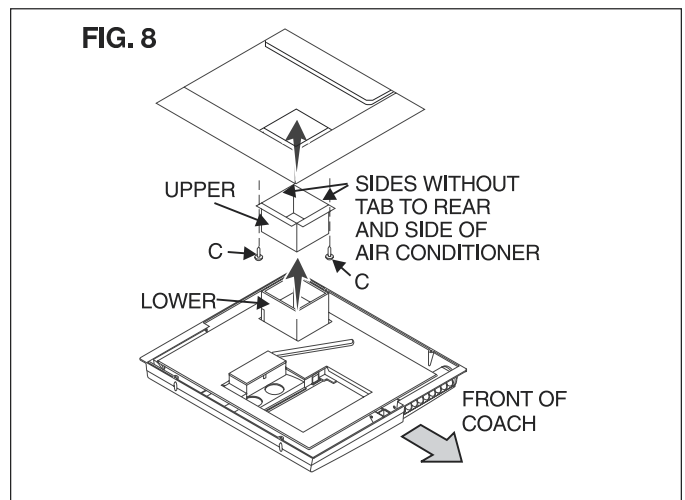

FIG. 8

2. Use two (2) #10 x 3/8" screws (C) to hold duct to base pan. Holes provided in bottom of basepan for these screws to go into.
- B. Check for correct alignment and adjust the unit as necessary (Roof Gasket centers over 14-1/4" ± 1/8" opening).
- C. Reach up into return air opening of the air conditioner and pull the unit electrical cord down for later connection. See FIG. 9.

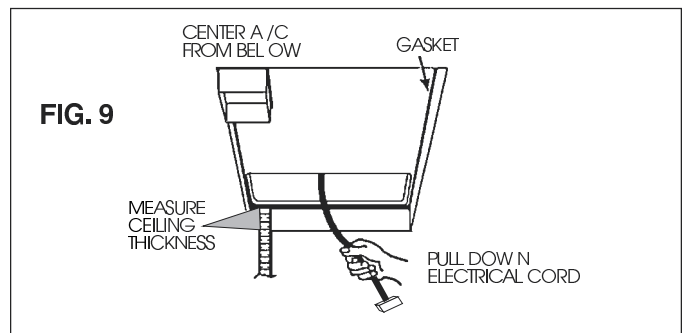

FIG. 9

## INSTALLATION AND OPERATING INSTRUCTIONS

- D. Measure (See FIG. 9) the ceiling to roof thickness:
1. If distance is 1"-2", remove perforated tabs from both upper and lower ducts.
  2. If distance is 2"-3", remove perforated tabs from bottom duct only.
  3. If distance is 3"-4", install ducts as received.
  4. If distance is 4"- 6", use optional duct adaptor, Part No. 3106775.004 and Bolt Kit, Part No. 3100895.006.

E. Install ceiling template by sliding lower duct over upper duct.

F. Start each mounting bolt by hand before tightening any of them. The four (4) threaded inserts in the base pan can be seen to aid in starting the bolts.

**EVENLY TIGHTEN MOUNTING BOLTS TO A TORQUE OF 40 TO 50 INCH POUNDS.**

This will compress the roof gasket to approximately 1/2". The bolts are self locking so over tightening is not necessary.

### CAUTION

If bolts are left loose there may not be an adequate roof seal or if overtightened, damage may occur to the air conditioner base or ceiling template. Tighten to torque specifications listed in this manual.

## 6. WIRING OF SYSTEM

**Note:** All wiring must comply with the National Electrical Code and any State or Local Codes or regulations.

### WARNING

Disconnect 115 volt AC. Failure to follow these instructions could create a shock hazard causing death or severe personal injury.

### WARNING

This product is equipped with a 3-wire (grounded) system for protection against shock hazard. Make sure that the appliance is wired into a properly grounded 115 volt AC circuit and the polarity is correct. Failure to do so could result in death, personal injury or damage to the equipment.

(Steps A. - F refer to FIG. 10.)

- A. Route supply line into junction box through provided Romex Connector (D). Six (6) inch leads are sufficient for connection to unit wires and ground screws.
- B. Connect white wire in junction box to white or neutral wire from supply line.

- C. Connect black wire in junction box to black or hot wire from supply line.
- D. Connect supply ground wire to identified ground screw in junction box.
- E. Install junction box cover with two (2) blunt point screws (C).
- F. Plug unit electrical cord into the mating connector on control box.

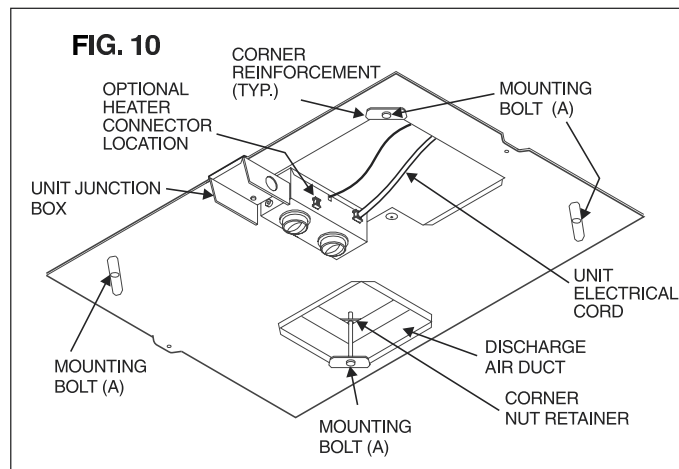

## 7. INSTALL AIR BOX

FIG. 11

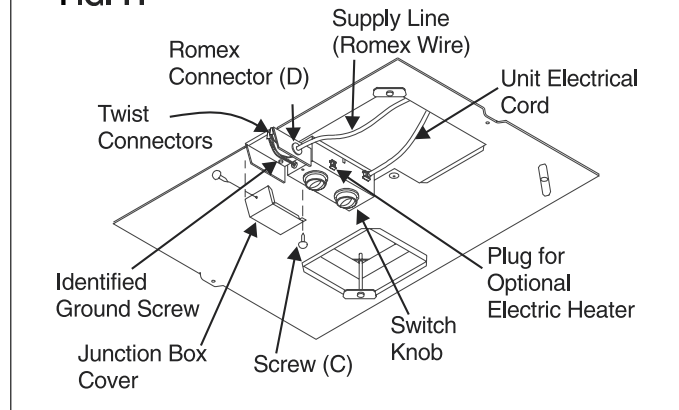

- A. Remove return air grille from air box by pulling in on half-round finger catches.

**Note:** If optional heat package is to be installed, do so at this time, before the air box is installed. Follow instructions with heat package for its installation procedure.

## INSTALLATION AND OPERATING INSTRUCTIONS

- B. Hold air box up to ceiling template and install three (3) #10 x 3/8" screws at air box mounting point. See FIG. 12.
- C. Snap hole plug (E) into place at rear of air box.
- D. Install four (4) wood screws (B) that hold air box tight to ceiling if so desired.
- E. Reinstall return air grille and filter into air box.
- F. The air conditioner installation is now complete. Turn on power to the unit for operational check. Please read Unit Operating Instructions before proceeding.

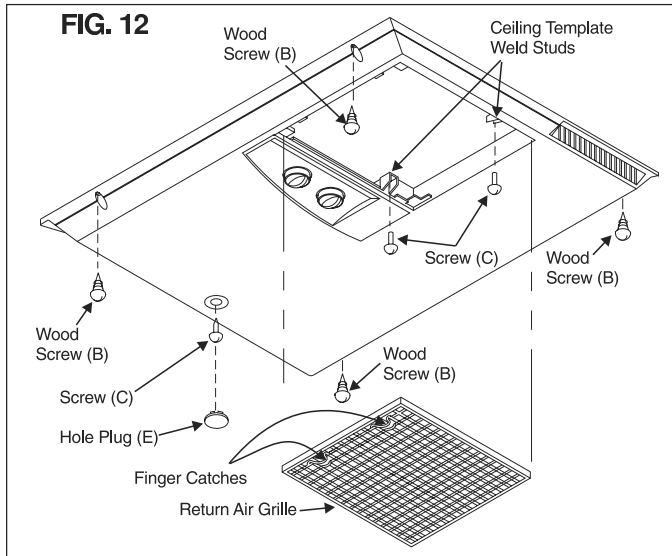

## 8. INSTALLATION ON TENT CAMPER ROOF

- A. The permanent wiring leading to unit junction box may originate in a flanged surface inlet located in roof section near the side wall. See FIG. 13.
- B. A unique outlet receptacle for air conditioner should be located in the side wall of vehicle beneath the flanged surface inlet.
- C. A cord set fabricated from an oil, water, and ozone resistant material, such as Type SJOW-A, shall be used to connect the flanged surface inlet and the air conditioning receptacle. This cord set shall be visible during use and shall not be installed in raceways or placed behind walls or cabinet panels.

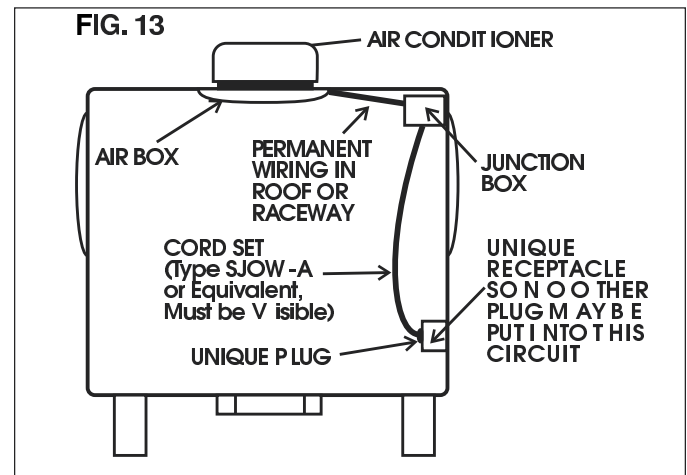

## OPERATING INSTRUCTIONS

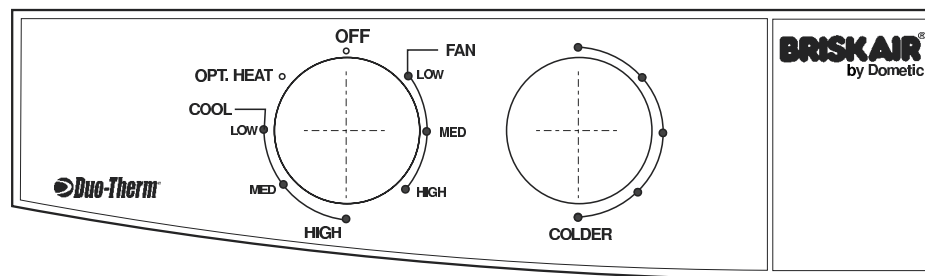

### 1. CONTROLS:

- A. The Selector Switch has eight positions including "OFF". This controls fan speed, heating mode, and cooling modes.
- B. The Thermostat controls the temperature range from 65° F on the coldest side to 90° F on the warmest side. In the cooling mode, the compressor ON/OFF controlled by the thermostat setting.

### 2. COOLING OPERATION:

- A. Set the thermostat at the desired temperature level.
- B. Select the fan speed that best satisfies your needs:
  - a. **HIGH COOL:** Selected when maximum cooling and dehumidification required.
  - b. **MED. COOL:** Selected when normal or average cooling required.
  - c. **LOW COOL:** Selected when room at desired comfort level and needs to be maintained. Normally this speed used for night time operation.



## INSTALLATION AND OPERATING INSTRUCTIONS

---

**Note:** The blower runs continuously to circulate air and maintain an even temperature. The compressor will come on as cooling is required to maintain the selected temperature level.

### 3. HEATING OPERATION:

(With Optional Heat Kit Installed)

**Note:** This electric heater will not replace a furnace for heating your RV in cold weather. The intent is to remove the chill on cool days or mornings.

- A. Turn the selector switch to "OPT. HEAT".
- B. The Heater will come on and begin heating.
- C. When desired temperature level in RV is reached, move the selector switch to off position or fan position.

**Note:** Thermostat does not control heater ON/OFF cycle.

### 4. FAN OPERATION:

This will circulate the air in your RV without cooling or heating. There are three positions: HIGH FAN, MED. FAN or LOW FAN to select from, depending upon personal choice.

### 5. "OFF" POSITION: This is to turn Unit off.

---

## MAINTENANCE

### 1. AIR FILTER:

Periodically remove the return air filter located above the removable panel in the air box. Wash the filter with soap and warm water, let dry and then reinstall.

**Note:** Never run the air conditioner without return air filter in place. This may plug the unit evaporator coil with dirt and may substantially affect the performance of the unit.

### 2. AIR BOX HOUSING:

Clean air box housing and control panel with a soft cloth dampened with a mild detergent. Never use furniture polish or scouring powders.

### 3. FAN MOTOR:

Factory lubricated and requires no service under normal use.

### 4. FROST FORMATION ON COOLING COIL:

Under certain conditions, frost may form on the evaporator coil. If this should occur, inspect the filter and clean if dirty. Make sure air louvers are not obstructed. Air conditioners have a greater tendency to frost when the outside temperature is relatively low. This may be prevented by adjusting the thermostat control knob to a warmer setting (counter clockwise). Should frosting continue, operate on LOW, MED. or HIGH FAN setting until the cooling coil is free of frost.

If your unit fails to operate or operated improperly, check the following before calling your service center.

---

## SERVICE - Unit Does Not Operate

1. If RV connected to motor generator, check to be sure motor generator is running and producing power.
2. If RV connected to power supply by a land line, check to be sure line is sized properly to run air conditioner load and it is plugged into power supply.
3. Check your fuse or circuit breaker to see if it is open.
4. After the above checks, call your local service center for

further help. This unit must be serviced by qualified service personnel only.

When calling for service, always give the air conditioner Model Number and Serial Number. This information can be found on unit rating plate located on the base pan near the return air opening. Return air grille must be removed from air box to view.

# INSTALLATION AND OPERATING INSTRUCTIONS

## MOUNTING PARTS

- A. (4) 1/4" — #20 x 7" bolts



- B. (4) #8 x 5/8" long sharp point wood screws



- C. (7) #10 x 3/8" blunt point tapping screws



- D. (1) Romex connector



- E. (1) Hole Plug



## AIR CONDITIONING UNIT

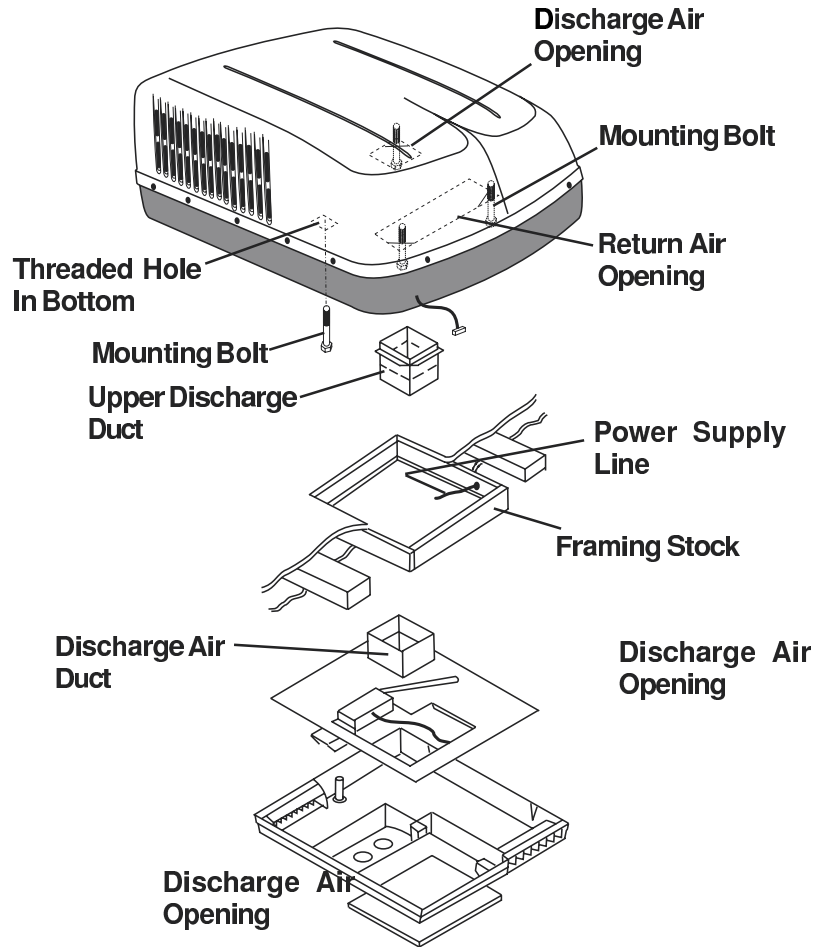

## AIR BOX - CONTROLS WIRING DIAGRAM

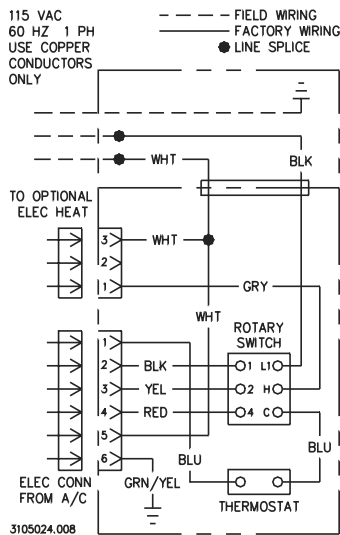

## AIR CONDITIONER - WIRING DIAGRAM

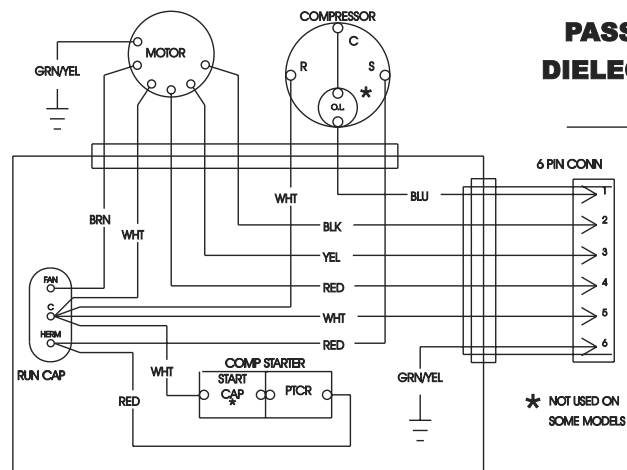

3105022.033