

Penguin Series Plastic Drain Pan Extension Installation Instructions

Contents of Kit:
(1) Air Dam
(1) Instructions

Tools and Supplies:
Phillips Screw Driver
5/16" Nut Driver
Silicone Sealant

1. GENERAL INFORMATION

This kit is designed to extend the height of the drain pan.

The repair procedure is done from the top side, therefore it is necessary to remove the outer shroud and evaporator cover.

⚠ WARNING

Disconnect 115 volt AC. Failure to follow these instructions could create a shock hazard causing death or severe personal injury.

2. REPAIR PROCEDURE

- A. Turn air conditioner off and disconnect 115 Volt AC power.
- B. Remove outer shroud and evaporator cover. This will expose the evaporator and plastic drain pan. See FIG. 1.

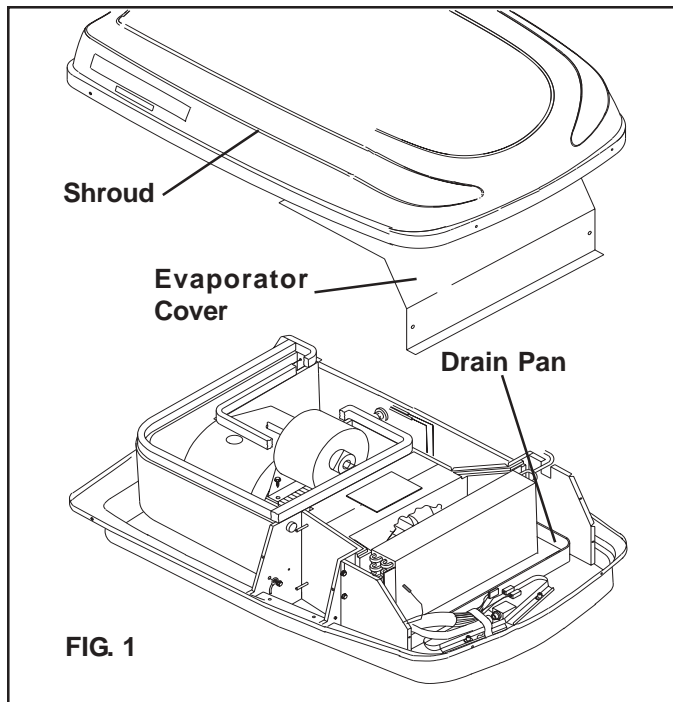

- C. Perform a visual inspection of the drain pan:
 1. Check along the front lip and behind the evaporator coil on the rear lip of the plastic drain pan. See FIG. 2.

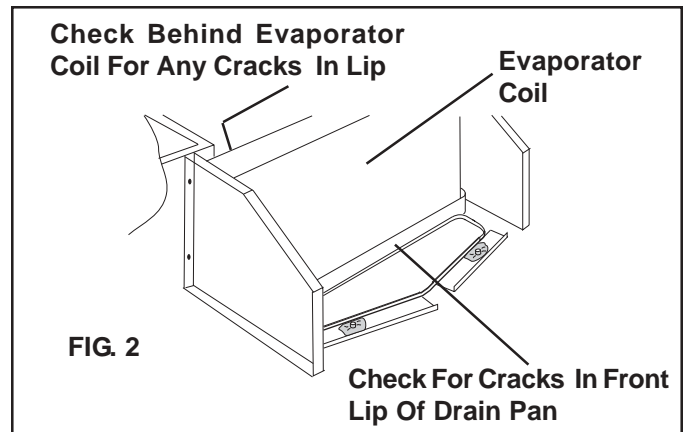

2. If any cracks are found replace unit. Contact Technical Service Department for proper authorization at 800-216-5115
3. If no cracks are located proceed to Step D.

Important: The area being sealed must be free of water and dry before applying sealant.

If you have any questions regarding this procedure call the Technical Service Department at 800-216-5115.

CAUTION

Sharp fin edges on coil will cut. Cover coil with cardboard to prevent injury.

- D. Use a long applicator to apply silicone sealant between the coil header and plastic drain pan. See FIG. 4. Repeat on opposite end. Follow manufacturer's safety instructions listed on tube.
- E. Place air dam on the rear lip of the plastic drain pan. See FIG 3 and 4. Be sure to press air dam completely down on the lip.
 - 1. Use a long applicator to apply silicone sealant to both ends of the air dam. Sealant must extend down to the bottom of the drain pan.

Note: The sealant will skin over in approximately 2 to 4 minutes.
- F. Make sure the cold control is snapped on the third turn bend from the top of the evaporator coil. Replace the evaporator cover and outer shroud.

Important: Do not run air conditioner or expose this area to water for at least 24 hours. This will allow the sealant to setup properly.

